



## *Shift2Rail* Joint Undertaking Multi-Annual Action Plan

*The European Railway Sector Proposal for the development of the general strategic priorities defined in the Shift2Rail Master Plan in the Shift2Rail Programme under the European Union's H2020 Framework Programme for Research and Innovation*

Brussels, November 2015



**Page Intentionally Blank**



<p><b><i>Shift2Rail</i></b></p> <p><b>Multi-Annual Action Plan</b></p>
--

<b>Document ID N°:</b>		<b>Version:</b>		<b>Date:</b>	
------------------------	--	-----------------	--	--------------	--

<b>Filename:</b>	
------------------	--

<b>Revision History Table</b>		
Version n°	Issue Date	Reason for change
DRAFT	12/10/2015	
REV 1	12/11/2015	Conformity of text: grammar, spelling, tables and typos  Includes comments from Scientific Committee, State Representative Group, European Railway Agency and European Commission
REV 2	20/11/2015	Editorial harmonisation and replacement of the term “homologation” with the appropriate technical legal terminology
REV 3	26/11/2015	TD values harmonisation following MA negotiations, additional Scientific Committee and European Commission comments included



# Shift2Rail MAAP

## Table of Contents

SHIFT2RAIL MAAP.....	4
TABLE OF CONTENTS.....	4
GLOSSARY.....	14
PART 1 – SHIFT2RAIL .....	17
PROMOTING THE MODAL SHIFT AND THE COMPETITIVENESS OF THE EUROPEAN RAILWAY INDUSTRY .....	17
1.    MEETING THE CHALLENGES SET IN HORIZON 2020 .....	17
2.    THE RATIONALE FOR SHIFT2RAIL.....	18
3.    THE STRUCTURE OF SHIFT2RAIL .....	19
PART 2 – SHIFT2RAIL .....	21
PROGRAMME SCOPE AND STRUCTURE .....	21
1.    STRUCTURE OF THE SHIFT2RAIL PROGRAMME.....	21
2.    SUMMARY OF MAJOR DEMONSTRATIONS AND TECHNOLOGY DEVELOPMENTS .....	22
2.1.    The System Platform Demonstration scenarios .....	23
PART 3 –SHIFT2RAIL .....	26
DETAILED MULTIANNUAL ACTION PLAN.....	26
1.    IP1 – COST EFFICIENT AND RELIABLE TRAINS.....	26
1.1.    Context and motivation.....	26
1.2.    Objectives of the IP and expected results .....	27
1.3.    Past and ongoing European & national research projects .....	30
1.4.    Set-up and structure of IP1.....	31
1.4.1.    Structure of the IP.....	31
1.4.2.    Involvement of Members in IP1 activities .....	33
1.5.    The Technical Demonstrators of IP1.....	34
1.5.1.    TD1.1 Traction Systems demonstrator .....	34
1.5.1.1.    Concept and objectives of the Traction Systems Demonstrator .....	34
1.5.1.2.    Technical ambition of the Traction Systems Demonstrator .....	36
1.5.1.3.    Specific Demonstration activities and contribution to ITDs/SPDs.....	38
1.5.1.4.    Impact of the Traction Systems Demonstrator .....	41
1.5.1.5.    Implementation of the work programme .....	43
1.5.1.6.    Planning and budget:.....	54
1.5.2.    TD1.2 Train Control and Monitoring System Demonstrator .....	54
1.5.2.1.    Concept and objectives of the TCMS Demonstrator .....	54
1.5.2.2.    Technical ambition of the TCMS Demonstrator .....	57
1.5.2.3.    Specific Demonstration activities and contribution to ITDs/SPDs.....	64

1.5.2.4.	Impact of the TCMS Demonstrator .....	64
1.5.2.5.	Implementation of the work programme .....	68
1.5.2.6.	Planning and budget:.....	75
1.5.3.	TD1.3 Carbody Shell Demonstrator .....	75
1.5.3.1.	Concept and objectives of the Carbody Shell Demonstrator .....	75
1.5.3.2.	Technical ambition of the Carbody Shell Demonstrator .....	78
1.5.3.3.	Specific Demonstration activities and contribution to ITDs/SPDs.....	88
1.5.3.4.	Impact of the Carbodyshell Demonstrator.....	88
1.5.3.5.	Implementation of the work programme .....	90
1.5.3.6.	Planning and budget:.....	95
1.5.4.	TD1.4 Running Gear Demonstrator .....	95
1.5.4.1.	Concept and objectives of the Running Gear Demonstrator .....	95
1.5.4.2.	Technical ambition of the Running Gear Systems Demonstrator .....	99
1.5.4.3.	Specific Demonstration activities and contribution to ITDs/SPDs.....	103
1.5.4.4.	Impact of the Running Gear Demonstrator.....	103
1.5.4.5.	Implementation of the work programme .....	107
1.5.4.6.	Planning and budget:.....	117
1.5.5.	TD1.5 Brake Systems Demonstrator.....	117
1.5.5.1.	Concept and objectives of the Demonstrator .....	117
1.5.5.2.	Technical ambition of the Brakes Systems Demonstrator .....	118
1.5.5.3.	Specific demonstration activities and contribution to ITDs/SPDs.....	124
1.5.5.4.	Impact of the Brakes System Demonstrator .....	125
1.5.5.5.	Implementation of the work programme .....	127
1.5.5.6.	Planning and budget:.....	135
1.5.6.	TD1.6: Doors and Access Systems Demonstrator.....	135
1.5.6.1.	Concept and objectives of the Doors and Access Systems Demonstrator .....	135
1.5.6.2.	Technical ambition of the Doors and Access Systems Demonstrator .....	138
1.5.6.3.	Specific Demonstration activities and contribution to ITDs/SPDs.....	142
1.5.6.4.	Impact of the Doors and Access Systems Demonstrator .....	143
1.5.6.5.	Implementation of the work programme .....	145
1.5.6.6.	Planning and budget:.....	151
1.5.7.	TD1.7: Train Modularity In Use (TMIU) .....	151
1.5.7.1.	Concept and objectives of the Demonstrator .....	151
1.5.7.2.	Technical ambition of the Interiors modular systems Demonstrator .....	155
1.5.7.3.	Specific Demonstration activities and contribution to ITDs/SPDs.....	160
1.5.7.4.	Impact of the Train MIU Demonstrator.....	161
1.5.7.5.	Implementation of the work programme .....	163
1.5.7.6.	Planning and budget.....	168
2.	IP2 – ADVANCED TRAFFIC MANAGEMENT AND CONTROL SYSTEMS .....	169
2.1.	Context and motivation.....	169
2.2.	Objectives of the IP and expected results .....	169
2.3.	Past and ongoing European & national research projects .....	172
2.4.	Set-up and structure of IP2.....	173
2.4.1.	Structure of the TDs.....	173

2.5.	The Technical Demonstrators of IP2.....	177
2.5.1.	TD2.1: Adaptable communications for all railways (quality of service, interfaces to signalling).....	177
2.5.1.1.	Concept and objectives of the Adaptable communications Demonstrator .....	177
2.5.1.2.	Technical ambition of the Adaptable Communications for all Railways .....	179
2.5.1.3.	Specific Demonstration activities and contribution to ITDs/SPDs.....	180
2.5.1.4.	Impact of the Adaptable Communications for all Railways.....	182
2.5.1.5.	Implementation of the work programme .....	183
2.5.1.6.	Planning and budget.....	185
2.5.2.	TD2.2: Railway network capacity increase (ATO up to GoA4 – UTO).....	186
2.5.2.1.	Concept and objectives .....	186
2.5.2.2.	Technical ambition.....	188
2.5.2.3.	Specific Demonstration activities and contribution to ITDs/SPDs.....	190
2.5.2.4.	Expected impact .....	192
2.5.2.5.	Implementation of the work programme .....	193
2.5.2.6.	Planning and budget:.....	200
2.5.3.	TD2.3 Moving Block.....	200
2.5.3.1.	Concept and Objectives.....	200
2.5.3.2.	Technical Ambition .....	202
2.5.3.3.	Specific Demonstration Activities and Contribution to ITDs/SPDs.....	203
2.5.3.4.	Impact.....	204
2.5.3.5.	Implementation of the Work Programme.....	205
2.5.3.6.	Planning and budget.....	210
2.5.4.	TD2.4: Fail-Safe Train Positioning (including satellite technology) .....	210
2.5.4.1.	Concept and Objectives of the Fail-Safe Train Positioning (including satellite technologies) .....	210
2.5.4.2.	Technical ambition of the Fail-Safe Train Positioning (including satellite technologies) .....	214
2.5.4.3.	Specific Demonstration activities and contribution to ITDs/SPDs.....	217
2.5.4.4.	Impact of the of the Fail-Safe Train Positioning (including satellite technologies) ...	218
2.5.4.5.	Implementation of the work programme .....	220
2.5.4.6.	Planning and budget.....	238
2.5.5.	TD2.5: On-board Train Integrity .....	238
2.5.5.1.	Concept and Objectives of the On-board Train Integrity .....	238
2.5.5.2.	Technical ambition of the On-board Train Integrity.....	240
2.5.5.3.	Specific Demonstration activities and contribution to ITDs/SPDs.....	241
2.5.5.4.	Impact of the On-board Train Integrity .....	242
2.5.5.5.	Implementation of the work programme .....	244
2.5.5.6.	Planning and budget:.....	247
2.5.6.	TD2.6: Zero on-site testing (control command in lab demonstrators).....	247
2.5.6.1.	Concept and objectives of the Zero on-site testing Demonstrator .....	247
2.5.6.2.	Technical ambition of the Zero on-site testing Demonstrator .....	249
2.5.6.3.	Specific Demonstration activities and contribution to ITDs/SPDs.....	252
2.5.6.4.	Impact of the Zero on-site testing Demonstrator .....	253
2.5.6.5.	Implementation of the work programme .....	255

2.5.6.6.	Planning and budget:.....	259
2.5.7.	TD2.7: Formal methods and standardisation for smart signalling systems .....	259
2.5.7.1.	Concept and objectives of Formal Methods and standardisation for smart signalling systems .....	259
2.5.7.2.	Technical Ambition of the Demonstrator .....	261
2.5.7.3.	Expected impacts.....	263
2.5.7.4.	Implementation .....	265
2.5.7.5.	Planning and budget:.....	265
2.5.8.	TD2.8: Virtually – Coupled Train Sets (VCTS).....	265
2.5.8.1.	Concept and objectives of the Virtually – Coupled Train Sets Demonstrator.....	265
2.5.8.2.	Technical ambition of the Virtually – Coupled Train Sets Demonstrator .....	267
2.5.8.3.	Specific Demonstration activities and contribution to ITDs/SPDs.....	270
2.5.8.4.	Impact of the Virtually – Coupled Train Sets Demonstrator .....	270
2.5.8.5.	Implementation of the work programme .....	271
2.5.8.6.	Planning and budget:.....	273
2.5.9.	TD2.9: Traffic management evolution.....	274
2.5.9.1.	Objectives and Concept of a new advanced Traffic Management System .....	274
2.5.9.2.	Ambition of the Advanced Traffic Management System .....	275
2.5.9.3.	Impact of the Advanced Traffic Management System .....	277
2.5.9.4.	Implementation of the work programme .....	278
2.5.9.5.	Planning and budget:.....	284
2.5.10.	TD2.10: Smart radio-connected all-in-all wayside objects .....	284
2.5.10.1.	Concept and objectives of the “Smart radio-connected all-in-all wayside objects” Demonstrator .....	284
2.5.10.2.	Technical ambition of the “Smart radio-connected all-in-all wayside objects” Demonstrator .....	286
2.5.10.3.	Specific Demonstration activities and contribution to ITDs/SPDs.....	287
2.5.10.4.	Impact of the “Smart radio-connected all-in-all wayside objects” Demonstrator....	289
2.5.10.5.	Implementation of the work programme .....	290
2.5.10.6.	Planning and budget:.....	293
2.5.11.	TD2.11: Cyber Security .....	293
2.5.11.1.	Concept and objectives of the Cyber Security Demonstrator .....	293
2.5.11.2.	Technical ambition of the Cyber Security Demonstrator .....	296
2.5.11.3.	Specific Demonstration activities and contribution to ITDs/SPDs.....	303
2.5.11.4.	Impact of the Cyber Security Demonstrator .....	304
2.5.11.5.	Implementation of the work programme .....	306
2.5.11.6.	Planning and budget:.....	312
3.	IP3 – COST EFFICIENT AND RELIABLE INFRASTRUCTURE .....	312
3.1.	Context and motivation .....	312
3.2.	Objectives of the IP and expected results .....	313
3.3.	Past and ongoing European & national research projects .....	315
3.4.	Structure and set-up of IP3.....	316
3.4.1.	Structure .....	316
3.4.2.	Links to other IPs .....	318

3.4.3.	Approach in IP3.....	319
3.5.	The Technology Demonstrators of the Cost Efficient and Reliable Trains Innovation Programme.....	322
3.5.1.	TD3.1 Enhanced Switch & Crossing System Demonstrator.....	322
3.5.1.1.	Concept and objectives of the Enhanced Switch & Crossing System Demonstrator.....	322
3.5.1.2.	Technical ambition of the Enhanced Switch & Crossing System Demonstrator.....	324
3.5.1.3.	Specific Demonstration activities and contribution to ITDs/SPDs.....	329
3.5.1.4.	Impact of the Enhanced Switch & Crossing System Systems Demonstrator.....	331
3.5.1.5.	Implementation of the work programme.....	335
3.5.1.6.	Planning and budget.....	340
3.5.2.	TD3.2 Next Generation Switch & Crossing System Demonstrator.....	341
3.5.2.1.	Concept and objectives of the Enhanced Switch & Crossing System Demonstrator.....	341
3.5.2.2.	Technical ambition of the Enhanced Switch & Crossing System Demonstrator.....	344
3.5.2.3.	Specific Demonstration activities and contribution to ITDs/SPDs.....	349
3.5.2.4.	Impact of the Enhanced Switch & Crossing System Systems Demonstrator.....	351
3.5.2.5.	Implementation of the work programme.....	355
3.5.2.6.	Planning and budget.....	361
3.5.3.	TD3.3 Optimised Track System.....	362
3.5.3.1.	Concept and objectives of the Optimised Track System.....	362
3.5.3.2.	Technical ambition of the Optimised Track System.....	364
3.5.3.3.	Specific Demonstration activities and contribution to ITDs/SPDs.....	372
3.5.3.4.	Impact of the Optimised Track System.....	375
3.5.3.5.	Implementation of the work programme.....	377
3.5.3.6.	Planning and budget.....	382
3.5.4.	TD3.4 Next Generation Track System.....	383
3.5.4.1.	Concept and objectives of the Next Generation Track System.....	383
3.5.4.2.	Technical ambition of the Next Generation Track System.....	386
3.5.4.3.	Specific Demonstration activities and contribution to ITDs/SPDs.....	394
3.5.4.4.	Impact of the Next Generation Track System.....	396
3.5.4.5.	Implementation of the work programme.....	398
3.5.4.6.	Planning and budget.....	403
3.5.5.	TD3.5 Proactive Bridge and Tunnel Assessment, Repair and Upgrade Demonstrator.....	404
3.5.5.1.	Concept and objectives of the Proactive Bridge and Tunnel Assessment, Repair and Upgrade Demonstrator.....	404
3.5.5.2.	Technical ambition of the Proactive Bridge and Tunnel Assessment, Repair and Upgrade Demonstrator.....	406
3.5.5.3.	Specific Demonstration activities and contribution to ITDs/SPDs.....	409
3.5.5.4.	Impact of the Proactive Bridge and Tunnel Assessment, Repair and Upgrade Demonstrator.....	411
3.5.5.5.	Implementation of the work programme.....	413
3.5.5.6.	Planning and budget.....	417





3.5.6.	TD3.6: Dynamic Railway Information Management System (DRIMS) Demonstrator .....	419
3.5.6.1.	Concept and objectives of the DRIMS Demonstrator .....	419
3.5.6.2.	Technical ambition of the DRIMS Demonstrator .....	422
3.5.6.3.	Specific Demonstration activities and contribution to ITDs/SPDs.....	427
3.5.6.4.	Impact of the DRIMS Demonstrator .....	429
3.5.6.5.	Implementation of the work programme .....	433
3.5.6.6.	Planning and budget.....	438
3.5.7.	TD3.7: Railway Integrated Measuring and Monitoring System (RIMMS) Demonstrator .....	439
3.5.7.1.	Concept and objectives of the RIMMS Demonstrator .....	439
3.5.7.2.	Technical ambition of the RIMMS Demonstrator.....	441
3.5.7.3.	Specific Demonstration activities and contribution to ITDs/SPDs.....	444
3.5.7.4.	Impact of the RIMMS Demonstrator .....	447
3.5.7.5.	Implementation of the work programme .....	450
3.5.7.6.	Planning and budget.....	453
3.5.8.	TD3.8: Intelligent Asset Management Strategies Demonstrator (IAMS) .....	454
3.5.8.1.	Concept and objectives of the IAMS Demonstrator.....	454
3.5.8.2.	Technical ambition of the IAMS Demonstrator.....	457
3.5.8.3.	Specific Demonstration activities and contribution to ITDs/SPDs.....	462
3.5.8.4.	Impact of the IAMS Demonstrator .....	465
3.5.8.5.	Implementation of the work programme .....	468
3.5.8.6.	Planning and budget.....	473
3.5.9.	TD3.9: Smart Power Supply Demonstrator .....	474
3.5.9.1.	Concept and objectives of the Smart Power Supply Demonstrator.....	474
3.5.9.2.	Technical ambition of the Smart Power Supply Demonstrator.....	476
3.5.9.3.	Specific Demonstration activities and contribution to ITDs/SPDs.....	480
3.5.9.4.	Impact of Smart Power Supply Demonstrator .....	482
3.5.9.5.	Implementation of the work programme .....	484
3.5.9.6.	Planning and budget.....	488
3.5.10.	TD3.10: Smart Metering for Railway Distributed Energy Resource Management System Demonstrator.....	489
3.5.10.1.	Concept and objectives of the Smart Metering Demonstrator.....	489
3.5.10.2.	Technical ambition of the Smart Metering Demonstrator.....	491
3.5.10.3.	Specific Demonstration activities and contribution to ITDs/SPDs.....	498
3.5.10.4.	Impact of the Smart Metering Demonstrator .....	500
3.5.10.5.	Implementation of the work programme .....	504
3.5.10.6.	Planning and budget.....	506
3.5.11.	TD3.11: Future Stations Demonstrator .....	507
3.5.11.1.	Concept and objectives of the Future Stations Demonstrator.....	507
3.5.11.2.	Technical ambition of the Future Stations Demonstrator.....	511
3.5.11.3.	Specific Demonstration activities and contribution to ITDs/SPDs.....	514
3.5.11.4.	Impact of the Future Stations Demonstrator .....	515
3.5.11.5.	Implementation of the work programme .....	518
3.5.11.6.	Planning and budget.....	521

4.	IP4 – IT SOLUTIONS FOR ATTRACTIVE RAILWAY SERVICES .....	522
4.1.	Context and motivation .....	522
4.2.	Objectives of the IP and expected results .....	524
4.3.	Past and ongoing European & national research projects .....	529
4.4.	Set-up and structure of IP4.....	529
4.4.1.	Structure of the IP.....	529
4.4.2.	Approach within the IP .....	531
4.4.3.	Links to Other IPs, and ITDs .....	533
4.4.4.	Involvement of Members in activities .....	534
4.5.	The Technical Demonstrators of IP4.....	535
4.5.1.	TD4.1 Interoperability Framework .....	535
4.5.1.1.	Concept and objectives of the Interoperability Framework Demonstrator.....	535
4.5.1.2.	Technical ambition of the Interoperability Framework Demonstrator.....	539
4.5.1.3.	Specific Demonstration activities and contribution to ITDs/SPDs.....	543
4.5.1.4.	Impact of the Interoperability Framework Demonstrator .....	544
4.5.1.5.	Implementation of the work programme .....	545
4.5.1.6.	Planning and budget.....	549
4.5.2.	TD4.2 Travel Shopping .....	549
4.5.2.1.	Concept and objectives of the Travel Shopping Demonstrator .....	549
4.5.2.2.	Technical ambition of the Travel Shopping Demonstrator .....	553
4.5.2.3.	Specific Demonstration activities and contribution to ITDs/SPDs.....	557
4.5.2.4.	Impact of the Travel Shopping Demonstrator .....	558
4.5.2.5.	Implementation of the work programme .....	560
4.5.2.6.	Planning and budget.....	566
4.5.3.	TD4.3 Booking & Ticketing.....	566
4.5.3.1.	Concept and objectives of the Booking & Ticketing Demonstrator .....	566
4.5.3.2.	Technical ambition of the Booking & Ticketing Demonstrator .....	568
4.5.3.3.	Specific Demonstration activities and contribution to ITDs/SPDs.....	571
4.5.3.4.	Impact of the Booking & Ticketing Demonstrator.....	572
4.5.3.5.	Implementation of the work programme .....	573
4.5.3.6.	Planning and budget.....	577
4.5.4.	TD4.4 Trip Tracker .....	577
4.5.4.1.	Concept and objectives of the Trip Tracker Demonstrator.....	577
4.5.4.2.	Technical ambition of the Trip Tracker Demonstrator .....	581
4.5.4.3.	Specific Demonstration activities and contribution to ITDs/SPDs.....	582
4.5.4.4.	Impact.....	583
4.5.4.5.	Implementation of the work programme .....	584
4.5.4.6.	Planning and budget.....	586
4.5.5.	TD4.5 – Travel Companion .....	586
4.5.5.1.	Concept and objectives .....	586
4.5.5.2.	Technical ambition.....	591
4.5.5.3.	Specific demonstration activities and contribution to ITDs/SPDs.....	594
4.5.5.4.	Impact.....	594
4.5.5.5.	Implementation of the work programme .....	596
4.5.5.6.	Planning and budget.....	600

4.5.6.	TD4.6: Business Analytics Platform .....	600
4.5.6.1.	Concept and objectives of the Business Analytics Demonstrator .....	600
4.5.6.2.	Technical ambition of the Business Analytics Demonstrator .....	602
4.5.6.3.	Specific Demonstration activities and contribution to ITDs/SPDs.....	605
4.5.6.4.	Impact of the Business Analytics Demonstrator .....	605
4.5.6.5.	Implementation of the work programme .....	607
4.5.6.6.	Planning and budget.....	609
4.5.7.	ITD4.7: Overall IP4 Coordination and demonstration .....	609
4.5.7.1.	Concept and objectives of the ITD7.....	609
4.5.7.2.	Impact of the IP4 – ITD7 .....	611
4.5.7.3.	Implementation of the IP4 – ITD7 .....	612
5.	IP5 – TECHNOLOGIES FOR SUSTAINABLE AND ATTRACTIVE EUROPEAN RAIL FREIGHT .....	615
5.1.	Context and motivation.....	615
5.2.	Objectives of the IP and expected results .....	617
5.3.	Past and ongoing European & national research projects .....	620
5.4.	Set-up and structure of IP5.....	620
5.4.1.	Structure .....	620
5.4.2.	Involvement of Members in activities .....	621
5.5.	The Technical Demonstrators of IP5.....	622
5.5.1.	TD 5.0 – Business analytics and implementation strategies .....	622
5.5.1.1.	Concept and objectives of TD5.0 .....	622
5.5.1.2.	Technical ambition of TD5.0 .....	625
5.5.1.3.	Specific Demonstration activities and contribution to ITDs/SPDs.....	625
5.5.1.4.	Impact of TD5.0 .....	625
5.5.1.5.	Implementation of the work programme .....	626
5.5.1.6.	Planning and budget.....	628
5.5.2.	TD5.1 Freight electrification, brakes and telematics.....	629
5.5.2.1.	Concept and objectives .....	629
5.5.2.2.	Technical ambition of the Freight electrification, brakes and telematics demonstrator.....	632
5.5.2.3.	Specific Demonstration activities and contribution to ITDs/SPDs.....	633
5.5.2.4.	Impact of the Telematics, electrification, automatic coupling and condition based maintenance .....	636
5.5.2.5.	Implementation of the work programme .....	638
5.5.2.6.	Planning and budget.....	643
5.5.3.	TD5.2 Access and Operation.....	643
5.5.3.1.	Concept and objectives of Access and Operation .....	643
5.5.3.2.	Technical ambition of Access and Operation .....	646
5.5.3.3.	Specific Demonstration activities and contribution to ITDs/SPDs.....	648
5.5.3.4.	Impact of the Access and Operation Demonstrator.....	651
5.5.3.5.	Implementation of the work programme .....	652
5.5.3.6.	Planning and budget.....	655
5.5.4.	TD5.3 Wagon design.....	656
5.5.4.1.	Concept and objectives of the Wagon design Demonstrator .....	656

5.5.4.2.	Technical ambition of the Wagon design Demonstrator .....	659
5.5.4.3.	Specific Demonstration activities and contribution to ITDs/SPDs.....	662
5.5.4.4.	Impact of the Wagon design Demonstrator.....	663
5.5.4.5.	Implementation of the work programme .....	665
5.5.4.6.	Planning and budget.....	668
5.5.5.	TD 5.4 Novel Terminal, Hubs, Marshalling Yards, Sidings .....	669
5.5.5.1.	Concept and objectives of TD 5.4 .....	669
5.5.5.2.	Technical ambition of TD 5.4 .....	671
5.5.5.3.	Specific Demonstration activities and contribution to ITDs/SPDs.....	675
5.5.5.4.	Impact of the Demonstrator.....	675
5.5.5.5.	Implementation of the work programme .....	677
5.5.5.6.	Planning and budget.....	681
5.5.6.	TD 5.5 New Freight Propulsion Concepts .....	681
5.5.6.1.	Concept and objectives of the New Freight Propulsion Demonstrators.....	681
5.5.6.2.	Technical ambition of the Systems Demonstrator .....	685
5.5.6.3.	Specific Demonstration activities and contribution to ITDs/SPDs.....	689
5.5.6.4.	Impact of the Systems Demonstrator.....	690
5.5.6.5.	Implementation of the work programme .....	691
5.5.6.6.	Planning and budget.....	696
5.5.7.	TD 5.6 Autonomous train operation.....	696
5.5.7.1.	Concept and objectives of TD 5.6.....	696
5.5.7.2.	Technical ambition of TD 5.6 .....	698
5.5.7.3.	Specific Demonstration activities and contribution to ITDs/SPDs.....	701
5.5.7.4.	Impact of the Freight ATO demonstrator .....	702
5.5.7.5.	Implementation of the work programme .....	703
5.5.7.6.	Planning and budget.....	708
6.	CCA – CROSS CUTTING ACTIVITIES .....	708
6.1.	Context and motivation.....	708
6.2.	Objectives and expected results of the CCA.....	709
6.3.	Past and ongoing European & national research projects .....	712
6.4.	Set-up and structure of the CCA.....	713
6.4.1.	Structure .....	713
6.4.2.	Approach within the CCA.....	716
6.4.3.	Involvement of Members in activities .....	717
6.5.	Work Areas of the CCA .....	718
6.5.1.	Work Area 1 – Long-term needs and socio-economic research.....	718
6.5.1.1.	Concept and objectives .....	718
6.5.1.2.	Implementation of the work programme .....	722
6.5.1.3.	Planning and budget.....	727
6.5.2.	Work Area 2 – KPI method development and integrated assessment .....	728
6.5.2.1.	Concept and objectives .....	728
6.5.2.2.	Impact.....	728
6.5.2.3.	Implementation of the work programme .....	729
6.5.2.4.	Planning and budget.....	736



6.5.3.	CCA Work Area 3 – Safety, Standardisation, Smart Maintenance, Smart Materials & Virtual certification .....	737
6.5.3.1.	Sub-work area 3.1 Safety.....	737
6.5.3.2.	Sub-work area 3.2 Standardisation .....	742
6.5.3.3.	Sub-work area 3.3 Smart Maintenance.....	748
6.5.3.4.	Sub-work area 3.4 Smart Materials.....	759
6.5.3.5.	Sub-work area 3.5 Virtual Certification .....	764
6.5.4.	Work Area 4 –Smart Mobility .....	771
6.5.4.1.	Sub-work area 4.1 Smart Planning .....	772
6.5.4.2.	Sub-work area 4.2 Integrated Mobility Management (I2M).....	780
6.5.5.	Work Area 5 Energy and Sustainability .....	788
6.5.5.1.	Sub work area 5.1 Energy .....	788
6.5.5.2.	Sub Work Area 5.2 Noise and Vibration .....	796
6.5.6.	Work Area 6 – Human Capital .....	809

# Glossary

Abbreviation	
AC	Alternating Current
ATO	Automatic Train Operation
B2B	Business to Business
BIM	<b>Bridge Information Models</b>
CBTC	Communications Based Train Control (Urban rail)
CER	Community of European Railway and Infrastructure Companies
CFRP	Carbon fibre reinforced plastic
DERMS	Distributed Energy Resource Management System
DG MOVE	Directorate General for Mobility and Transport
DG R&I	Directorate General for Research & Innovation
DRIMS	Dynamic Railway Information Management System
EC	European Commission
EMC	Electromagnetic Compatibility
EMS	Energy Management System
EMV	EuroCard Mastercard Visa
EN	European Norm
ERA	European Railway Agency
ERP	Enterprise Risk Planning (WRONG USE IN THE TEXT: Management instead of Planning)
ERRAC	European Rail Research Advisory Council
ERTMS	European Rail Traffic Management System
ETCS	European Train Controlling System
EU	European Union
FMEA	Failure Modes And Effects Analysis
FMECA	Failure Mode Effects And Criticality Analysis
FP6, FP7	EU Sixth and Seventh Framework Programmes for Research
FRP	Fibre reinforced polymer
GNSS	Global Navigation Satellite System
GSM-R	Global System for Mobile Communications – Railway
H2020	Horizon 2020, EU framework programme for Research and Innovation
HVAC	Heating, Ventilation, Air Conditioning
HSL	High Speed Lines
HST	High Speed Trains

<b>HW and SW</b>	Hardware and Software
<b>IA</b>	Integrated Assessment
<b>IAM</b>	Intelligent Asset Management
<b>IATA</b>	The Air Transport Association
<b>ICT</b>	Information and Communications Technology
<b>IM</b>	Infrastructure Manager
<b>IP</b>	Innovation Programme
<b>IPR</b>	Intellectual Property Rights
<b>ISA</b>	Independent Safety Assessor
<b>ISMES</b>	Intelligent System Maintenance Engineering and Strategies
<b>ISO</b>	International Standardisation Organisation
<b>IT</b>	Information Technology
<b>ITD</b>	Integrated Technology Demonstrator
<b>JTI</b>	Joint Technology Initiative
<b>JU</b>	Joint Undertaking
<b>KPIs</b>	Key Performance Indicators
<b>LCC</b>	Life Cycle Cost
<b>LTE</b>	Long-Term Evolution (standard for wireless communication)
<b>MoU</b>	Memorandum of Understanding
<b>MS</b>	Member State
<b>MTBF</b>	Mean Time Between Failures
<b>NFC</b>	Near Field Communication
<b>PI</b>	Performance Indicator at local Traction TD or Traction component level
<b>R&amp;I</b>	Research and Innovation
<b>RAM4S</b>	Reliability Availability Maintainability, Safety, Security, Sustainability, Supportability
<b>RAMS</b>	Reliability and Maintainability System
<b>RCF</b>	Rolling Contact Fatigue
<b>RCM</b>	Reliability Centred Maintenance
<b>RCMS</b>	Rail Corrugation Measuring Systems
<b>RDERMS</b>	Railway dedicated Distributed Energy Resource Management System
<b>RFID</b>	Radio Frequency Identification
<b>RIMMS</b>	Railway Integrated Measuring and Monitoring System
<b>RS</b>	Rolling Stock
<b>RU</b>	Railway Undertaking
<b>S&amp;C</b>	Switches & Crossings

<b>S2R</b>	SHIFT2RAIL
<b>SiC</b>	Silicon carbide
<b>SIL</b>	Safety Integrity Level (according to IEC 61508 standard)
<b>SME</b>	Small and Medium Enterprise
<b>SPD</b>	System Platform Demonstration
<b>STM</b>	Specific Transmission Module
<b>TAF</b>	Telematic Application for Freight
<b>TAP</b>	Telematic Application for Passengers
<b>TCMS</b>	Train Control and Monitoring System
<b>TD</b>	Technology Demonstrator
<b>TEN-T</b>	Trans-European transport network
<b>TRL</b>	Technology Readiness Level
<b>TSI</b>	Technical Specifications for Interoperability
<b>UIC</b>	International Union of Railways
<b>UITP</b>	International Association of Public Transport
<b>UNIFE</b>	Association of the European Rail Manufacturing Industry
<b>UNISIG</b>	Union Industry of Signalling
<b>WMMS</b>	Wayside Measuring & Monitoring Systems
<b>WP</b>	Work Package



## Part 1 - Shift2Rail

# Promoting the modal shift and the competitiveness of the European railway industry

### 1. Meeting the Challenges set in Horizon 2020

The EU's new programme for research and innovation (R&I), Horizon 2020 (H2020)<sup>1</sup>, will run from 2014 to 2020 with an estimated total budget of EUR 77 billion, of which roughly EUR 6.339 billion will go towards support to the "Smart, green and integrated transport" challenge, one of the 8 Societal Challenges identified under H2020, and reflecting the Union's "Europe 2020" strategy.

The aim of the "Smart, green and integrated transport" challenge is to boost the competitiveness of the European transport industries and achieve a European transport system that is resource-efficient, climate-and-environmentally-friendly, safe and seamless for the benefit of all citizens, the economy and society.

Four key objectives have been identified under the programme:

- **Resource efficient transport that respects the environment**, by making aircraft, vehicles and vessels cleaner and quieter to minimise transport systems' impact on climate and the environment, by developing smart equipment, infrastructures and services and by improving transport and mobility in urban areas.
- **Better mobility, less congestion, more safety and security**, with a substantial reduction of traffic congestion and improvement in the mobility of people and freight, by developing new concepts of freight transport and logistics and by reducing accident rates, fatalities and casualties, and improving security.
- **Global leadership for the European transport industry** by reinforcing the competitiveness and performance of European transport manufacturing industries and related services including logistic processes, and retain areas of European leadership (e.g. aeronautics).
- **Socio-economic and behavioural research and forward looking activities** in support to improved policy making, to help promote innovation and meet the challenges raised by transport and the societal needs related to it.

Within the "Smart, green and integrated transport" challenge, a budget of EUR 450 million has been earmarked for research and innovation activities in the rail sector. This represents close to three

---

<sup>1</sup> Regulation of the European Parliament and of the Council establishing Horizon 2020-The Framework Programme for Research and Innovation (2014-2020), SEC(2011) 1427-Volume 1 and SEC(2011) 1428-Volume 1.

times more than the EUR 155 million in Union funding than was available under the previous research framework programme (FP7), which ran from 2007 to 2013.

This increase in funding for the rail sector is in line with the Union's Europe 2020 strategy for smart, sustainable, and inclusive growth. Indeed, the overall aim is to achieve a more competitive and resource-efficient European transport system with a view to addressing major societal issues such as rising traffic demand, congestion, security of energy supply and climate change. And, given rail's inherent advantages in terms of environmental performance, land use, energy consumption and safety, strengthening the role of rail – both passenger and freight – in the transport system is an important goal, which is also clearly set out in the Commission's 2011 Transport White Paper (“Roadmap to a Single European Transport Area – Towards a competitive and resource efficient transport system”).

The rail sector can and must further enhance its performance in these areas through innovation. Innovation should be envisaged as a tool with a dual purpose of helping to address short/medium term problems in the railway sector while also initiating a paradigm shift for a more ambitious future for the rail sector.

## 2. The Rationale for Shift2Rail

A key objective of H2020 is also to improve the efficiency of EU funding and better address societal challenges by pooling together existing R&I efforts and expertise, namely through Public-Private Partnerships (PPPs) in the form of Joint Undertakings.

In line with this, the Shift2Rail Joint Undertaking (S2R JU) was established by Council Regulation (EU) No 642/2014 of 16 June 2014 as a public-private partnership in the rail sector with a view to managing and coordinating all rail-focused research and innovation activities funded under Horizon 2020.

The main task of the S2R JU is to develop, integrate, demonstrate, and validate innovative railway technologies and solutions with the objective to improve the competitiveness and attractiveness of the European Railway Sector.

The performance of the railway system will only be improved if it is understood and managed as a whole system shared between many actors, with particular attention to the interfaces between the parts of the system managed by the different actors. By involving actors from the full value chain in the whole innovation cycle, the S2R JU will accelerate the development and market uptake of breakthrough solutions that have a real impact on the whole rail system.

The establishment of the S2R JU will enable railway stakeholders to build relationships together and develop strategic partnerships in a sector that has traditionally been overly segmented. This collaborative approach will consist on the R&D development, testing, and validation of demonstrations in real or simulated operational scenarios. This will ensure that the products developed by S2R JU are in line with the business and customer needs in the rail sector, and that they can be introduced to the market in a reliable way from the first day of entry into service, thereby contributing to enhanced reliability and quality of services in both the passenger and freight rail segments.

In practice, S2R JU will foster the introduction to the market of a new generation of high-quality reliable rolling stock, combined with intelligent traffic management and control systems, a new railway infrastructure system, and innovative IT solutions and services, that will radically improve capacity and performance of the railway system and facilitate cross-border railway operations throughout various Member States, while substantially reducing the life-cycle cost of rail services. For the EU passenger this will mean more travel options, more comfort, and improved punctuality. For the freight forwarder/shippers, this will mean that rail freight will become more cost effective, punctual, and traceable as a shipment option. For rail in general, this will mean more users and, thus, a step closer towards the paradigm of the modal shift from road to rail.

Importantly, all this will be developed by European companies, thereby increasing their competitiveness on the global marketplace.

### 3. The Structure of Shift2Rail

In accordance with the S2R JU Statutes, Article 5 states that the S2R JU will be composed of four main bodies:

- the Governing Board, which has the overall responsibility for the strategic orientation and the operations of the S2R Joint Undertaking and supervises the implementation of its activities; *(Articles 6, 7 & 8)*
- the Executive Director, who is a member of staff of the Joint Undertaking and is responsible for the day-to-day management of the S2R Joint Undertaking. He also manages the S2R Secretariat; *(Articles 9 & 10)*
- the Scientific Committee, which will advise on the scientific and technological priorities to be addressed in the annual work plans, and will be composed of world-renowned scientists providing scientific expertise and science-based recommendations to the S2R Joint Undertaking. The Scientific Committee is appointed by the Governing Board taking into consideration the potential candidates proposed by the States Representatives Group, by the ERRAC and by the European Railway Agency; *(Article 13)*
- the States Representatives Group, representing EU Members States and countries associated with the Horizon 2020 Framework Programme, which will inter alia give opinions on the strategic orientations of the JU, including on any updates of the S2R Master Plan and the annual work plans, as well as on the links between S2R activities and relevant national or regional research and innovation programmes. *(Article 14)*

The Scientific Committee and the States Representatives Group are advisory bodies to the S2R Joint Undertaking.

In addition to these four bodies, the Statutes also foresee:

- a specific advisory role for the European Railway Agency in contributing to the definition and implementation of the S2R Master Plan and to the annual work plans and ensuring that the Research and Innovation activities of S2R JU are leading to technical standards with a view to guaranteeing the interoperability and safety results. *(Article 12)*

- the establishment of Innovation Programmes' (IP) Steering Committees composed of representatives of the founding members and associated members, as well as of the S2R Programme Office, in charge of the technical input and the implementation for each IP. (*Article 11*)
- the possibility of creating a limited number of working groups to assist the JU in carrying out its tasks. (*Article 15*)

Currently, the Governing Board of the S2R JU has decided to establish the following working groups:

- a) System Integration Working Group(s) composed of S2R JU members, to ensure coordination of the activities of each Innovation Programme and to assist the JU in ensuring that the cross cutting themes are properly mainstreamed across all Innovation Programmes.
- b) User Requirements Working Group(s) composed of S2R JU members and non-members, to assist the JU in ensuring that technical solutions developed within S2R meet the specific needs of all relevant end users.
- c) Implementation and Deployment Working Group(s) composed of S2R JU members and non-members, to test the operational reliability of the results of Shift2Rail and thereby contribute to a more rapid uptake and large-scale deployment of the solutions developed through the Shift2Rail activities.

Figure 1 below provides a schematic overview of the current governance structure of the S2R JU.

**Figure 1: Graphic overview of the S2R JU governance structure**



## Part 2 - Shift2Rail

# Programme scope and structure

### 1. Structure of the Shift2Rail Programme

As indicated in the Shift2Rail Master Plan, the work conducted within the Shift2Rail framework will be structured around five asset-specific Innovation Programmes (IPs), covering all the different structural (technical) and functional (process) sub-systems of the rail system. These five IPs will be supported by work in five cross-cutting areas and themes (CCA), that are of relevance to each of the projects and take into account the interactions between the IPs and the different subsystems. This overall programme structure is schematised in Figure 2 below.

**Figure 2: Overall structure of the S2R JU programme**

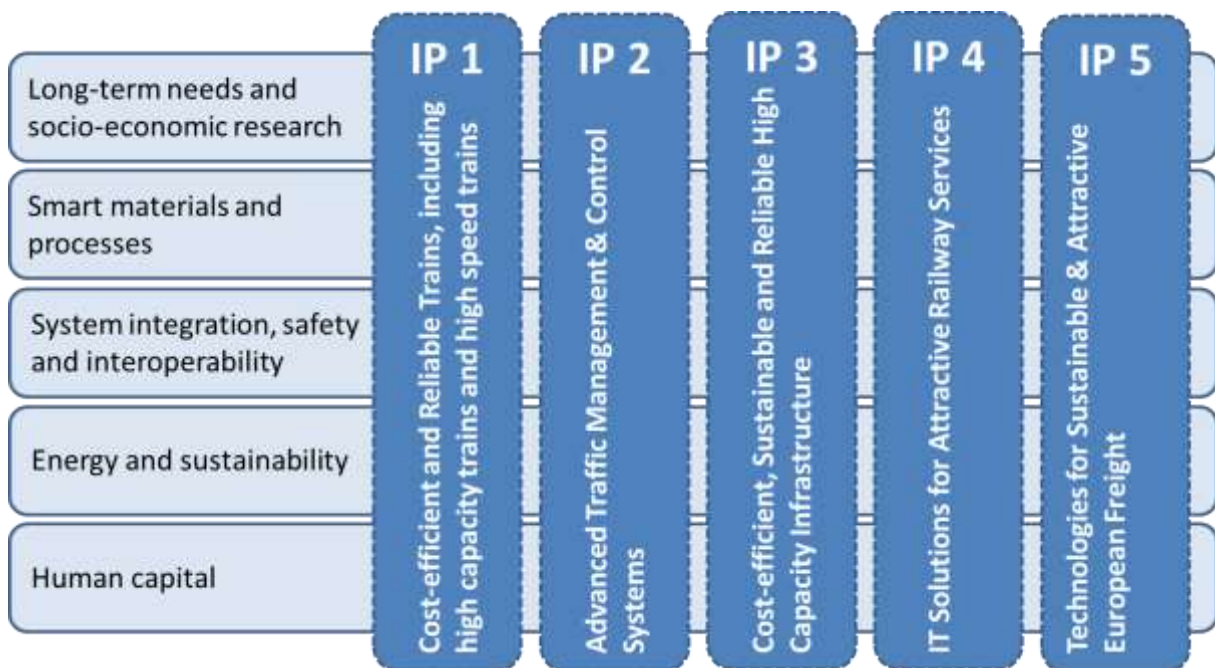

Shift2Rail will address the above-mentioned IPs and CCA by funding Research and Innovation activities that will range from applied research activities (TRL 1 to 3) to demonstration activities (TRL 4 to 7), i.e. from technology developments in lab to system prototype demonstrations in operational environments.

In addition, the Members of the Shift2Rail JU will be required to conduct additional activities with a view to leveraging the effect of the R&I activities undertaken within Shift2Rail. These activities are not eligible for financial support by the S2R JU and are not included in this MAAP but will contribute directly to the broader objectives set out in the Shift2Rail Master Plan.

## 2. Summary of Major Demonstrations and Technology Developments

Demonstration activities are a priority within Shift2Rail, as they will enable the entire rail sector to visualise and concretely test the transformations that they are able to create. Demonstrations will also enable a more appropriate quantification of the impact of each new technology (either alone or in combination with other innovations). Demonstration activities will also help at providing a first estimate of the potential for improvement in the sector at the levels of regional, national and EU transport network, which can be expected as a result of the developed innovations.

It is also of utmost importance that the rail industry demonstrates a tangible step change during the next decade, which will be visible to the public and generate interest in the railway domain. In addition, the realisation of key flagship demonstration will enhance the perceived innovation potential of the sector and revitalise the industry by attracting the next generation of top graduates from universities across Europe.

Furthermore, the development of collaborative demonstrators will foster internal industry communication and collaboration. Shift2Rail will also promote the realisation on integrated technology demonstrators (ITDs), which will combine the testing of different solutions in a single demonstrator, resulting therefore in economies of scales for the project development. This will allow a more collaborative system approach toward innovation, breaking possible silo between sub-systems developers. It will also help identifying at an early stage possible issued of compatibility in the integration of different solutions.

The demonstration of technical achievements, up to TRL 7, will be based on the three-fold architecture presented in Figure 3 below: technology demonstrators (TDs), integrated technology demonstrators (ITDs) and system platform demonstrators (SPDs).

**Figure 3: Structure of Demonstrators within Shift2Rail**

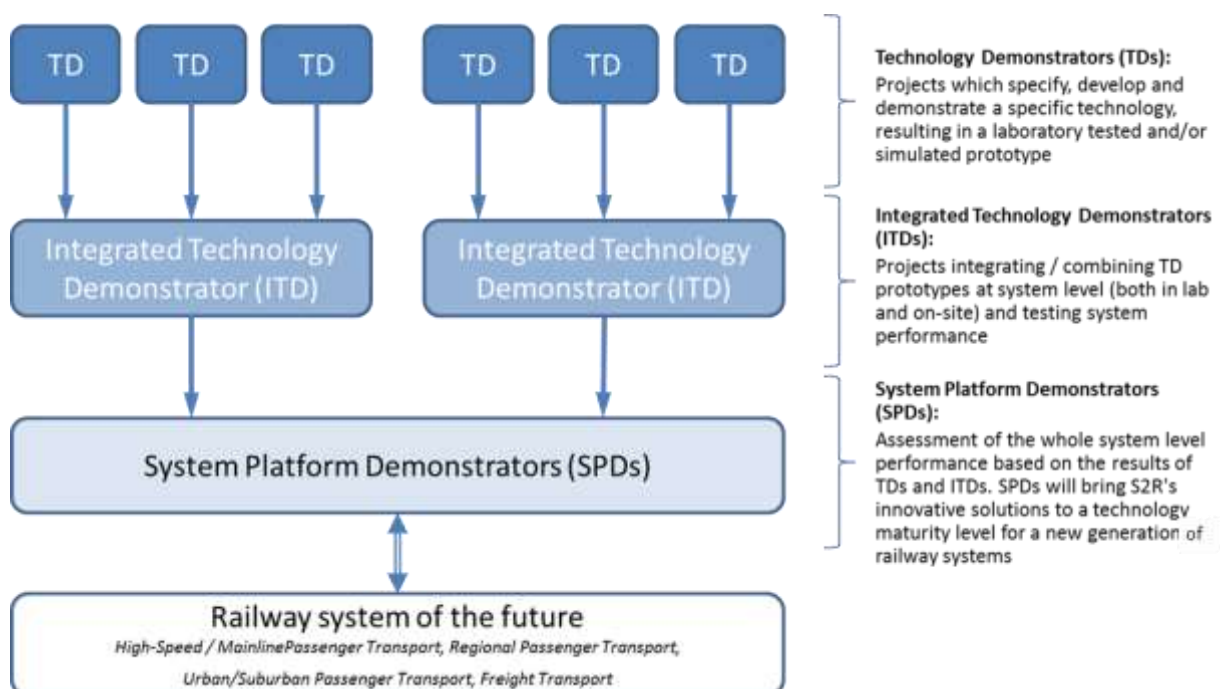



### **Technology Demonstrators (TDs)**

Technology Demonstrators will focus on the development or adoption of innovative technologies and models *within* the rail sub-systems identified in the Innovation Programmes. They will enable ground-breaking progress in key areas such as traction, automatic train operation and intelligent diagnosis and maintenance systems. They will seek inspiration from innovative technologies, materials and methods used or explored in other sectors. The innovations developed may consist of software and/or hardware systems.

Before being combined into Integrated Technology Demonstrators (ITDs), each TD will be tested (in labs on test benches, or existing trains) in one or more prototypes (differentiated if different business segments are addressed) to assess the individual performance of the technologies thus developed, and, where possible, demonstrate the conformity with technical requirements that apply to the product developed.

### **Integrated Technology Demonstrators (ITDs)**

The ITDs will allow for the testing of combinations of components and sub-systems already verified and validated within the Technology Demonstrators within virtual or physical railway environments for demonstrating the innovation potential of the components in different sub-systems and systems, taking into account functional and operational specifications and the technical interfaces among the various TD.

ITDs will also enable the analysis of compliance with the regulatory requirements, and the validation of technologies will be followed up with a controlled approach to future authorisation and certification work.

### **System Platform Demonstrations (SPDs)**

Ultimately, Shift2Rail will carry out proof and analysis of rail systems, design and functions on fully representative innovative railway configurations in an integrated environment, simulating real operational conditions.

#### **2.1. The System Platform Demonstration scenarios**

The System Platform Demonstrations will be created among the main rail market segments to simulate and test the interaction and impact of the various innovative systems resulting from the Shift2Rail activities in the specific environments of each of the relevant market segments. The proposed SPDs will cover the following segments: high-speed passenger rail, regional passenger rail, urban/suburban passenger rail and rail freight. These SPDs will also be complemented by reflection on key transversal issues (megatrends) which are critical for the sector: safety, security, energy, digitalisation, etc.

The design of demonstration platforms will take into account the specificities of each market segment, its particular challenges and needs as well as the promising market opportunities. Based on this initial assessment, the SPDs will demonstrate how the correct aggregation of different innovations can greatly contribute to improve the performance of the sector. This will be based on

an analysis of detailed KPIs on simulated models and measured against the S2R objectives as defined in the Master Plan.

In this respect, it is possible that the deliverables of the same TD are relevant for more than one of the different railway transportation segments. Results of one TD may therefore be demonstrated in more than one SPD if considered that these results correspond to the business needs of several rail market segments.

The exact definition of each SPD is part of the work to be done in the S2R System Integration working group of the JU taking into account the input from the broad stakeholder community (S2R user Requirements and Implementation working groups) as well as, where relevant / available the first results of the S2R lighthouse projects, funded under the H2020 first call. This is also expected to be the subject of activities carried out as a result of the 2015 S2R call for projects.

Overview of the key challenges for each of the SPDs defined in the S2R Master Plan:

### **High-speed passenger rail**

High speed has been a very successful and innovative rail market segment for several decades, and is often the preferred choice for long distance national and international travel. The technical and technological challenges related to high-speed and mainline rail are not just related to developing new types of rolling stock that provide comfortable transportation capacity for increasing numbers of passengers, but also to ensuring safe and efficient operation thanks to appropriate infrastructure design, enhanced traffic control and management systems, more efficient power systems, as well as shared track and corridor operations.

### **Regional passenger rail**

Regional rail is already serving as a backbone of the European transport system, expanding massively in past years. However, this segment remains affected by competition with the private car and by the life cycle cost of operation compared to bus services. The core challenge for this market segment is mainly to offer increased capacity to ever-increasing number of passengers, through improved system capacity, with enhanced traffic management and automation concepts and high-capacity rolling stock. These services are mostly operated under public service contracts and may share or not the infrastructure with mainline traffic. What is mostly at stake is making these services more attractive to customers, through increased reliability, frequency and speed and cutting costs, as well as an improved coordination with other public transport services and a better integration in regional mobility strategies.

Solutions with overall low life cycle costs are also needed for regional network having low traffic volumes to become or remain attractive.

### **Urban/suburban passenger rail**

Railway networks in urban and suburban areas play a prominent role in major cities and high-density areas, serving the daily needs of urban populations and offering an attractive alternative to the use of private car in more and more congested and polluted areas. These market segments are also experiencing growth, which will be important to manage through innovative solutions. They are also one for which existing rail infrastructure is not used according to its potential for supporting more



sustainable land use and transport policies. Cost effectiveness and increased attractiveness are also important challenges, requiring higher scales of proven, affordable technology and improved accessibility, comfort and security and innovative services based on ITS. Improvements through technical harmonisation of interfaces are also required.

### **Rail freight**

Rail freight is a key element in the establishment of a sustainable transport system. An efficient and reliable, high-quality rail freight system in Europe is indispensable for the competitiveness of the European economy, its industries, businesses and society, which are all making use of and rely on freight services. The low level of external costs generated by rail freight should make it the mode of choice for freight customers looking to reduce their environmental impact. However, the key challenge for rail freight to become a core link in intermodal transport is for it to be able to offer an attractive, reliable, rapid and cost-efficient alternative to road. The main objectives of this SPD should be to offer visible and viable solutions that increases productivity, reduces cost, optimises network capacity, and enables better quality of services through optimised logistic services and rail technology and that realise the full potential of digitalisation, appropriately meeting the customers' requirements.



## Part 3 -Shift2Rail

# Detailed multiannual action plan

### 1. IP1 – Cost Efficient and Reliable Trains

#### 1.1. Context and motivation

The ambitious objectives set out in the Shift2Rail Master Plan for the railway system of the future need to be supported by radical changes in the technologies applied in each of the components of the system, rolling stock being one of the key elements.

Traditionally, innovation in rolling stock has faced several obstacles, such as:

- The long life cycle of railway vehicles, which can last for more than 30 years tends to slow down the introduction of new developments;
- Due to the variety of operational environments across segments and different standards and solutions in different countries, many innovations cannot be widely applied and it is not possible to apply economies of scale and to obtain an adequate return on the investment on new innovative developments;
- The complexity of the whole railway system and the fragmentation of responsibilities makes preferable “service proven” solutions rather than new innovative ones.

Commercial pressure and political long-term vision have pushed the evolution of rolling stock in the last few years, but the aforementioned limitations have prevented industrial innovation to achieve its full potential, and have also often made it difficult for technically sound research developments to make their way to the real applications. In practice, innovation has most often been incremental, and so have been the benefits achieved by its implementation.

A sector-wide collaboration initiative like Shift2Rail offers the right environment to overcome this situation by:

1. Incorporating the standardisation perspective from the beginning of the activities, involving all stakeholders from the specifications phase, in order to ease the penetration of new technologies;
2. Incorporating cutting-edge technologies already in use in other sectors into railway vehicles;
3. Identifying incipient technological opportunities that could bring considerable benefits if they are used in trains.

With this view in mind, the IP1 of Shift2Rail is committed to develop the technologies for the next generation of railway vehicles that fulfil the expectations set at the Shift2Rail Master Plan.



## 1.2. Objectives of the IP and expected results

Taking the high-level objectives set out in the Shift2Rail Master Plan as a starting point, and considering the role that rolling stock plays within the whole railway system, the high-level objectives for IP1 can be summarised as follows:

1. Increase the physical capacity of vehicles and promote the enhancement of transport capacity of railway lines.
2. Reduce the travel disruptions for passengers by increasing operational reliability and availability of vehicles, either through the use of fundamentally more reliable components or system/subsystem architectures.
3. Reduce life cycle cost of the vehicle (reduction of maintenance, energy consumption ...) and of other subsystems interfacing with the vehicle (reduction of track damage ...).
4. Increase energy efficiency of the vehicle and reduce vehicle mass.

Fulfilling these objectives will guarantee that the Shift2Rail global objectives are achieved.

The high-level objectives need to be achieved through concrete actions. Concretely, the following technology developments can be expected to result from the work in IP1.

1. More efficient and lighter traction drives using the new generation of electronic material will be developed. With new power electronics able to control motors at a higher frequency, combined with the development of new generation permanent magnet motors based on buried magnets architecture, a step change in energy efficiency will be achieved as compared with existing permanent magnet synchronous motors and asynchronous induction motors.
2. The new drive-by-data concept for train control along with wireless information transmission will make new control functions possible, involving interaction between vehicles and consists, with high safety and reliability levels through very simple physical architectures. New generation TCMS will allow current bottlenecks caused by physically coupled trains to be overcome. Concepts made by different companies and with different interfaces could be virtually coupled and driven together, sharing the same traffic slot.
3. The new generation of bodyshells will be using composite or other lightweight materials. No rail vehicles are currently built from such materials, and such a step-change will lead to significantly lighter vehicles, carrying more passengers within the same axle load constraint, using less energy and having a reduced impact on the rail infrastructure.
4. A mechatronic bogie able to steer through points and crossings will open huge possibilities for a new design philosophy in collaboration with IP3. The main innovations in running gear lie in the possible combinations of new architectural concepts, new actuators in new lighter materials leading to new functionalities and significantly improved performance levels with the possibility of vibration energy recovery.
5. New braking systems with higher brake rates and lower noise emissions could give major capacity gains in terms of mass and volume in bogies, paving the way for a fresh revisit of bogie design. When these are combined with traction innovations, the next generation of passenger

rolling stock will be able to offer improvements in acceleration and deceleration rates leading to greater overall line capacity for trains.

6. Innovative doors will move away from current access solutions, based on honeycomb and aluminium or steel sheets, which still have drawbacks regarding energy consumption, and noise and thermal transmission. New lightweight composite structures could be made to react faster at existing safety and reliability levels, reducing platform dwell times and increasing overall line capacity. Customer-friendly information systems and improved access for people with reduced mobility using sensitive edges and light curtains are part of this new development.
7. New modular concepts of train interiors will allow operators adapting the vehicle layout to the actual usage conditions and will improve flow of passengers, thus optimising both the capacity of the vehicle and dwell times.

The following table summarises the main objectives of IP1 and provides an overview of some of the concrete deliverables that can be expected to result from the activities undertaken in the IP.

**Table 1: Objectives and challenges of IP1**

Objective	Result	Practical (concrete) Challenge
Line capacity increase	More space and weight available for passengers in each vehicle	Smaller and lighter power electronics and traction architecture concepts, along with simpler communications and electronics, lighter and wider carbody structures with an optimal architecture, lighter bogies and brakes will allow for new vehicle designs with more space for passengers.
	Better control on the vehicles on the line (in terms of passengers/hour)	Flexible coupling between trains will allow for flexible accommodation of the capacity of the line at peak times. The factors that increase operational reliability mentioned below will also increase moderately the capacity of the line
Operational reliability increase	Fundamentally more reliable technologies and components	Key elements and systems that are known to be more prone to operational failure (TCMS, Traction ...) based on novel technologies which show a better fundamental reliability
	Fundamentally simplified architectures, or architectures more suited to keep operation in case of failure	Train communications and control architecture, linking the functioning of all vehicle subsystems, based on new technologies allowing much lower physical complexity leading to much higher reliability. Similar concept to be applied to brakes and others
Railway system life cycle cost reduction	Reduction in the capital cost of the vehicle	New vehicle subsystems and components with better overall performance not showing any increase in cost. Better authorisation processes relying on virtual methods rather than on on-track tests
	Reduction in the need of vehicles for a given capacity	Vehicles with increased availability, directly related to the deliverables shown in section "Operational reliability increase"
	Reduction in the cost of maintaining the vehicles	Intrinsically more reliable system architectures and component technologies Better and more standard sensing to detect condition Vehicles with lower axleloads, lower unsprung mass and better curving performance
	Reduction in the cost of maintaining other parts of the railway system	Track friendly vehicles with lower axle loads, lower unsprung mass and better curving performance and ability to run through switches and crossings

Objective	Result	Practical (concrete) Challenge
	Reduction in the consumption of energy	As defined in the next lines
Mass reduction and energy efficiency	Reduction in the mass of the vehicle	Reduced weight of most bulky elements (Carbody, bogie, traction ...) combined with new, intrinsically lighter, architectures
	Increase in the energy efficiency and reduction of energy losses	Increase energy efficiency in traction / braking. Reduction of thermal losses (i.e. doors)
Noise reduction	Better calculation and design methods	Better techniques for assessment and prediction. Theoretical criteria to guide design
	Noise reduction oriented design	New innovative design features for traction, brakes, running gear, carbodyshell and doors

### 1.3. Past and ongoing European & national research projects

The IP1 of Shift2Rail will be supported to a great extent by many of the projects funded by the EU research programmes in the last few years. Shift2Rail will be an efficient tool to bring the results of these projects closer to the market, thus maximising the real benefits from the investment that European society has made in railway research in recent years. Details of the projects are presented in the section devoted to each technology demonstrator, but some of the most relevant ones to the activity proposed in Shift2Rail are briefly introduced here:

The outcomes from European research projects **MODTRAIN** (looking for innovative modular vehicle concepts, in particular for knowledge developed on auxiliary power systems, interface to traction and standardisation) and **MODURBAN** (dealing with common specifications and common architecture for urban rail systems) will be taken into account and used at the beginning of the development of the *Traction* Technology Demonstrator within IP1. The **RAILENERGY** and **OSIRIS** projects oriented to energy efficiency of trains offer the first building blocks to develop the major technologies (new semiconductors, motors ...) that will be used to build the traction systems of the future in Shift2Rail.

In the same way, the *TCMS* Technology Demonstrator will also take into account outputs from **MODTRAIN** as well as **INTEGRAIL** (addressing railway information systems and their integration within the major railway sub-systems – important also for the *Data management Shift2Rail System Integration Activity*). Moreover, important knowledge and innovative practices on “virtual coupling” coming from European aerospace research projects (**RESET**, **SOFIA**, **INOUI** and **ASSTAR**) will be used in the development of the *TCMS* Technology Demonstrator.

Future composite Carbodyshell to be developed in Shift2Rail will strongly rely on the results achieved in the FP7 project **REFRESCO**, whose aim is to develop suitable technical standards to allow the use of

new composite materials in structural applications in trains. These will also be useful for the work to be developed in the area of Doors.

The **MECHATRONIC TRAIN** project results (dealing with bogie architectures, sensors, actuators and processing to increase safety, reliability, and maintainability) will be taken into account and used at the beginning of the development of the *Running Gear Technology Demonstrator*.

The **MODBRAKE** project, which was oriented to develop modular brake system architectures, will be an input for the development of new generation brakes in Shift2Rail.

Finally, the **ROLL2RAIL** IP1 “lighthouse” H2020 project, which is currently under development, is oriented to kick-start many of the work lines of Shift2Rail and to mitigate potential risks at an early stage. The results of **ROLL2RAIL** will be incorporated to IP1 within the first 12-18 months after the start of Shift2Rail and will constitute an essential element towards the success of the programme.

## 1.4. Set-up and structure of IP1

### 1.4.1. Structure of the IP

Technologically speaking, trains are very much structured into subsystems, each of which are usually responsible for different functions in the vehicle. The realisation of these functions tends to be related to a specific type of technology that is able to provide a given performance at subsystem level.

This functional division of the vehicle is presented in Figure 4 and has been used as basis for the division in Technology Demonstrators (TDs) in Shift2Rail. Thanks to this strong function/subsystem/technology relationship, specialist teams will be able to develop the specific technologies to achieve the highest performance levels.

**Figure 4: Train functional breakdown into subsystems**

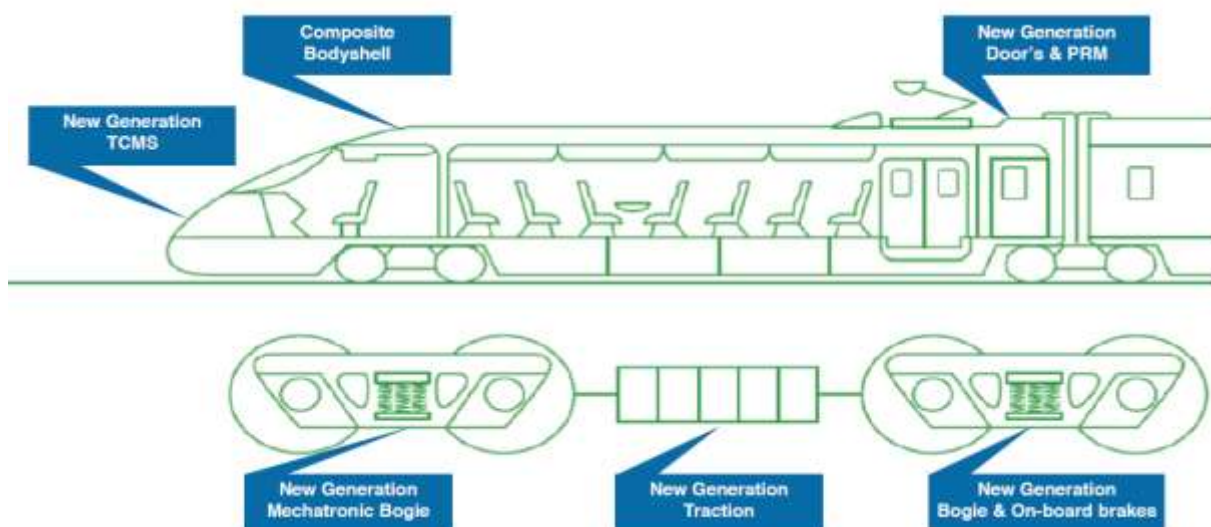



The choice of topics for work in IP1 has been made considering:

1. *Technological opportunities applicable to rolling stock subsystems*: Progress in fundamental technologies (e.g. new communications technologies, new power electronics components, innovative materials) has been analysed and potential transfer to railways of the most promising ones considered.
2. *Relevance to performance and integration possibilities* at vehicle and/or railway system level: Developments need to be useful when integrated with other components of system and have a meaningful impact a system level.

This approach leads to *parallel developments covering the different functions* to be provided by the vehicle, *which converge at a later stage into an integrated assessment (IA)* that constitutes the final quantitative measurement of the success of Shift2Rail

As the technologies proposed are in general function-oriented, they generally refer to a specific piece of equipment. However, in some cases, they have applicability to different TDs. A few examples of inter-related technological developments are:

- Drive-by-wire (TD1.2) TCMS and fail-to-safe electronic control for brakes (TD1.5) concepts rely on innovative safety critical electronics and software technologies
- Wireless TCMS (TD1.2) concepts and the standard running gear sensing (TD1.4) rely on wireless communications solutions
- Composite material technologies are present at carbody (TD1.3), doors (TD1.6) and running gear (TD 1.4) areas of work.

Even though a big part of the development effort is to be developed within the TDs, the development will be coordinated with other relevant activities within Shift2Rail, exploiting synergies when possible, and in all cases working together towards the achievement of the same railway system-level performance objectives

A more global view on functional interactions existing between TDs is given in Figure 5, which highlights not only the technological but also the functional interdependencies between TDs and IPs.



**Figure 5: IP1 TDs and map of inter-relationships**

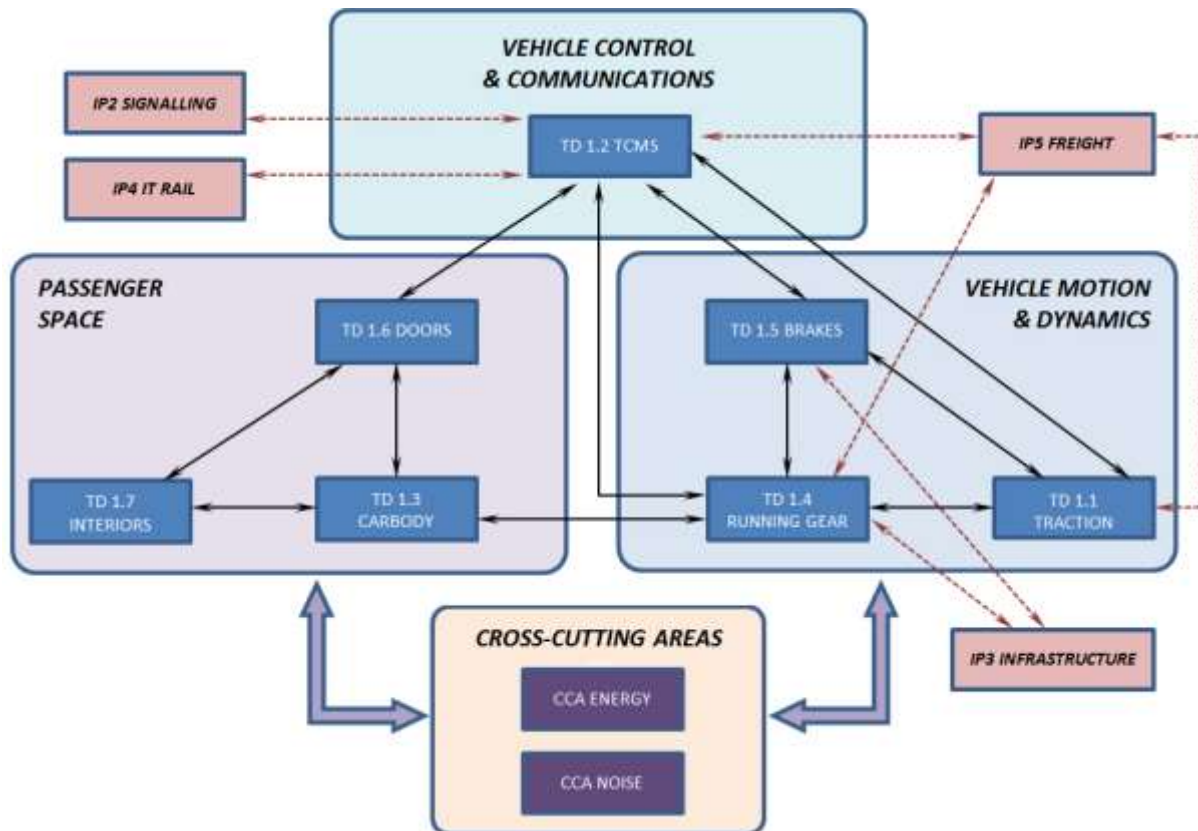

#### 1.4.2. Involvement of Members in IP1 activities

The membership of the IP1 of Shift2Rail includes all major European railway vehicle manufacturers, the principal manufacturers of major vehicle sub-systems, the two biggest train operators in Europe, and two of the biggest infrastructure managers. A strong involvement in complementary roles maximizes the chances of future implementation of the results in real applications in the sector.

Due to the technological nature of the work proposed, Members will rely on the involvement of highly specialised technological companies, research institutions, and universities with very specific technological skills that are essential to complete the work programme. Open Calls budget will allow involvement of the skills required at the right moment and for the right activity throughout the project.

## 1.5. The Technical Demonstrators of IP1

### 1.5.1. TD1.1 Traction Systems demonstrator

#### 1.5.1.1. Concept and objectives of the Traction Systems Demonstrator

The Traction Drive sub-system is one of the main sub-systems of a train as it moves the train converting energy from an electrical source (directly or via a chemical source) into a mechanical one.

In electrical trains, the physical scope of such a sub-system starts from the pantograph and ending with the motorised wheels. The main components are the main transformer, power bus, traction inverters, motors, gearbox and finally wheels. All those components are controlled by electronic hardware and software.

Current electronic technology used in Traction Drives is based on Silicon material such as the IGBT power semiconductor devices used as an electronic. However, this technology has major limitations leading e.g. to high losses, too many failures, heavy and large size equipment. The new emerging SiC technology provides high-speed switching capabilities with a low on-resistance.

The physical domains to master are multiple: electrical, mechanical, thermal, and automatic. A large number of norms and regulations have also to be taken into account for traction systems design, manufacturing, validation and certification.

The Traction Drive TD will carry out the necessary work in 4 major phases to bring to the market a new generation of traction drive equipment:

1. **Capture** necessary know-how, collaborate with partners having the expertise in SiC technology, energy storage, wheel motors.
2. **Progress and implement** new methodologies, tools, norms & standards on reliability, noise, virtual certification, smart maintenance.
3. **Develop** new Traction component and sub-systems including using the SiC technologies. Develop new traction architectures allowed by the new technology. Develop a traction system based on independently rotating wheels.
4. **Demonstrate** key achievements on three Rolling Stock Demonstrators (including metro and tramway for Urban) and finally implement physically the news equipment on a Metro, a Regional train and a HST.
5. **Conclude** on technical benefits.

#### **Specific achievements to be delivered by this TD:**

1. SiC based Traction system aligned with the Urban markets;
2. SiC based Traction system aligned with the Regional market;
3. Traction system based on independently rotating wheel for HST;
4. Breakthrough on aero-acoustic, electromagnetic and EMI noise reduction methodologies and prediction tools

5. Breakthrough on High reliability design methodology, simulation and test tools for Life Cycle Estimation of Critical Power Traction Electronics Components in Real Operational Conditions, condition based maintenance, applied to Traction TD development
6. Breakthrough on Validation and Virtual Certification methodologies, updated regulations, simulation tools and test bench to reduce test ring certification tests, cost and duration

**Objectives:**

The high-level objective of this Technical Demonstrator (TD) is to develop the new generation of Traction Drives using the new electronics materials becoming available. This TD will mainly bring to the railway market the SiC (Silicon Carbide) technology.

The following table gives the macro contribution of the TD towards the global S2R Master Plan objectives:

S2R Objectives	TD Objectives	Practical contribution (how)
Improved services and customer quality	<p>Increased availability</p> <p>Reduction of the volume of the Traction Drive equipment</p> <p>Reduce environmental impact</p>	<p>Increased reliability and less service disruptions thanks to the new breakthrough SiC technology.</p> <p>Reduction of the volume of large equipment will increase the space for passengers</p> <p>Reduction of noise emitted by Traction Drive Equipment</p>
Reduced system costs	<p>Reduction of operating and maintenance costs</p> <p>Reduction of certification costs</p>	<p>Reduction of energy consumption resulting from the new technology</p> <p>Reduction of maintenance costs</p>
Simplified business processes	<p>Improved standardisation and certification</p>	<p>Development of harmonized rules for certification</p> <p>Less on-site testing and more static tests on the bench combined with numerical simulation</p>

The following table summarizes the specific objectives and related deliverables of this Traction TD:

Objectives	Result	Practical (tangible) Deliverable
High reliability/availability and low maintenance costs Traction systems	<ol style="list-style-type: none"> <li>1) Breakthrough methods &amp; tools to design high reliability Traction</li> <li>2) High reliability new Traction Systems</li> </ol>	<ol style="list-style-type: none"> <li>1) New simulation tools and reliability database from field</li> <li>2) TRL7 demonstrators on 3 SPDs (Metro, Regional, HST trains)</li> </ol>
Low energy consumption Traction systems	New Traction system and Traction components optimised for energy savings	TRL7 demonstrators on 3 market segments
Traction Contribution to Train capacity	Low weight, low volume Traction systems or components	TRL7 demonstrators on 3 market segments
Traction Contribution to Train Capital cost reduction	<ol style="list-style-type: none"> <li>1) Breakthrough standards/Norms for Traction Certification aligned with IP1 Rolling set of text</li> <li>2) Virtual Certification simulators</li> </ol>	Quantification on use cases of “before/after” certification number of tests on: a) trains b) test bench c) simulator.
Low noise Traction with predictable acoustic signature	<ol style="list-style-type: none"> <li>1) Methodologies and simulation tool to design for low noise</li> <li>2) Low noise new component and Traction System</li> </ol>	<ol style="list-style-type: none"> <li>1) Predicted acoustic signatures by simulation</li> <li>2) TRL7 demonstrators on 3 market segments</li> </ol>

### **1.5.1.2. Technical ambition of the Traction Systems Demonstrator**

#### **State of the art**

Advanced semiconductor technology has always been a key component for the traction system. Former steps from line commutated thyristor converters to gate-turn-off thyristors and also from bipolar technology to IGBTs have been the enablers for step changes in performance of traction drives. Today the new emerging technology is the Silicon carbide (SiC) semiconductor technology vs. the existing Silicon (Si) Technology.

On SiC based Traction, the high-speed switching capabilities of SiC components with a low on-resistance are key characteristics for improved traction inverters. This combination of characteristics is not possible with existing silicon based components. Additional features include superior characteristics at high temperatures and significant lower switching loss. This can result in simplified cooling components and in general a much compacter design of the traction system overall.

On HST, a traction system based on independently rotating wheels will also improve HST’s performance through a distributed traction architecture with a low-floor concept that will contribute to an increase of the passenger’s per meter of train length, to an increase of the line occupancy and to lower the energy consumption.

Over the last two decades EU funded R&D projects have pushed different entities, companies and experts around a same objective: understand, develop and prepare deployment of all kind of

technology innovations via scientific and technical work, standardisation and pre-marketing studies. Industry, operators, infrastructure managers, suppliers, research laboratories, standardisation, organisation and many others have been involved in past successful project and will be involved in the coming Traction TD. The Traction TD will benefit from this very rich background.

**The Main past EU funded R&D projects relevant for this TD are:**

- Energy saving for Electric traction

**RailEnergy** (2006-2010) on electric and diesel Main Line trains energy reduction: The project targeted to save 6% of energy on the European Fleet. Several levers have been used: Operation, Infrastructure or Rolling stock with different solution at component level. Standardisation of energy calculation and verification is now at prEN50591 stage. There was no work on SiC technology applied to Traction neither wheel motor for HST.

**Osiris** (2012-2015): focused on urban railway systems reduction of energy. It led to the development of a SiC auxiliary converter that was tested on commercial operations on the Milano Metro. It constitutes one of the main starting points towards more complex developments in SiC technology to be held in this TD of Shift2Rail.

- Traction noise

**SILENCE IP** – Rail vehicle noise. In this project a source ranking for urban type of vehicles were done. There wasn't any development of simulation methodologies for electromagnetic-forces calculation and/or solutions tested in a real prototype.

- Certification

The field of certification covers different subtopics and several E.C R&D project work on certification like:

**EUREMCO**: One essential technical issue is the certification of the EMC. In the project EUREMCO (European Railway Electro Magnetic Compatibility), they aim to harmonise and reduce the certification process of rail vehicles against Electromagnetic Compatibility (EMC). With the use of new semiconductors like the SiCs the switching behaviour changes dramatically. The existing research in Traction TD has to be expanded with the new challenges of SiC semiconductors.

**Pantotrain**: Improvement of certification of quality of pantograph power collection

**Ambition and side-by-side comparison between state-of-art and the technology resulting from S2R**

Whereas Japanese companies e.g. Hitachi, have announced on the development of inverters using SiC technology, very little work has been done in Europe.

The following table presents the steps of progress targeted within the Traction TD work:

State-of-the-art	New Generation Traction
Heavy and very large Traction equipment	Smaller and lighter medium frequency transformers, high speed motors and natural cooling systems thanks to new SiC semi-conductor technology
Good energy efficient traction systems based on Si IGBT semiconductors	Very high energy efficient traction systems thanks to new SiC semi-conductors very low losses technology
Current traction systems based on Si technology leads to too much noise emission (electro-magnetic and cooling). Too late discovery of noise problems during the development cycle.	Early stage low noise traction system and component design thanks to predicted calculated noise signature. Low noise prototype developed and tested within the Traction TD
Too low reliability and no capability to predict life time of semi-conductors and traction components in real train operational conditions	New methodology to predict lifetime, improved design and validation processes to progress on reliability during exploitation.
Long and costly validation and certification process	New methodology and tools to implement more virtual validation and certification of the full traction systems and components. Transfer of tests from train to static test bench and simulators.
No standard in SiC semi-conductors	European and Worldwide standardisation especially on packaging of semi-conductor chips
Complicated and non-harmonised (European level) certification standards. No standards on Traction system virtual certification	Simplified framework for Traction certification, recommendations for more virtual certification.
No technology available for the combination of the independent wheel and the distribution traction concepts	New developments for more efficient (in terms of operation and of energy consumption) and with more capacity trains by combining these two concepts

### ***1.5.1.3. Specific Demonstration activities and contribution to ITDs/SPDs***

#### **Generic description of the demonstrations**

The objective of the demonstration is to generate physical demonstrators, integrated in rolling-stock, suitable for performing track tests, either in commercial lines or test rings (TRL7 demonstrators).

The works are done in three steps: integration of traction equipment into three different Rolling Stock trains, assessments and a final step on demonstration conclusion.

In particular the demonstrators will focus on obtaining experimental results to obtain:

- New traction components performances and behaviour.
- New control strategies performances and behaviour.
- Traction local performance: acoustic noise level, reliability/availability (failure rates, aging, etc.), energy, etc

- Traction EMI levels.

Additionally, the real experimental results will be used to compare with the results obtained previously in virtual certification platforms (virtual certification SW, simulation tools and HIL platforms) in order to validate and assess the accuracy of such platforms.

All the prototypes developed in Task 1.1.2 will be tested on test track or commercial lines in different segment applications, as outlined in the next pages.

#### **New SiC based traction converter for Metro application (TRL7)**

The objective is to generate a physical demonstrator of a metro train integrating a SiC based traction system, suitable for performing tests on the field, either in commercial lines or test rings.

The scope includes all the required work to install fully functional prototypes of SiC based traction converters in a real train. These tasks, among others, include:

- Validation plan: definition of validation parameters and test procedures to fully validate a functional prototype of a SiC based traction system for a metro application in order to verify the performance of the traction system and contrast the expected targets (KPIs) defined in the specification project phase with the results of the experimental validation.
- Train adaptation: definition of method of integration (permanent or transitory modifications), definition of the necessary modifications on the train and implementation of the modifications on the train.
- Traction system adaptation: definition and implementation of required electromechanical adaptations of the SiC based traction converters developed during the project. The required application software that will allow the integration of the traction system on the train will also be developed in this phase.
- Integration of converters: manufacturing and integration of all the equipment of the traction chain with SiC based traction converters necessary for the validation purposes of this project in the real train. In order to integrate such prototype in an existing train and depending on the application and the validation plan it may be required to manufacture many prototypes of the same equipment.
- Static tests: static tests will be carried out to verify that the integration has been done successfully being them ready to start the testing on the field.

During the project phase, a concrete metro application will be selected. The costs of the metro vehicle (renting of the vehicle, operational costs, etc.) during the tests and demo will be covered by Members. In order to minimize and rationalize the vehicle costs it is intended to use the same train as ITD for the IP1 TD1 Traction and IP1 TD2 TCMS field validation tests on metro application.

#### **New SiC based traction converter for Regional application (TRL7)**

A fully functional prototype of SiC based traction converter for the Regional train will be assessed.



The contribution from major operator members is needed for this task to bring all needed support like providing a train, allowing modification and helping to have the authorisation to run on test track at least.

This work is divided in three working-blocks:

- Definition of real trains to be used as test trains for the integration of demonstrators: Description of the train, characteristics, ownership, method of integration, maximum duration for the testing and number of demonstrators to be integrated. During the project phase, a concrete regional application will be selected depending on the results of the project and the availability of the demonstration.
- Definition of Validation and Test Procedure to fully validate a functional prototype of a SiC based traction system and e-transformer for a regional application. It will also be meant to contrast the expected targets defined in the project phase with the results of the experimental validation.
- Integration of a fully functional prototype of a SiC based traction system and e-transformer on a Regional application. This will include all the equipment of the traction chain, especially the SiC based traction converter, necessary for the validation purposes of this project. The application software that will allow the integration of the traction system on the train will be developed and “factory” testing to verify that the integration has been done
- Demonstration and assessment: demonstrate and asses the results of the outputs of the R&D activities carried out during the project based on the experimental results obtained in the rolling stock tests in the field
- Global Regional Traction TD conclusions:
  - Consolidate and deliver all technical assessment reports after all Traction TD tasks execution
  - Deliver synthesis reports for Cross Cutting Activities like Noise and Vibration, Energy
  - Provide business oriented reports (expected time to market for future products, magnitude of Industry R&D costs to achieve this, investment cost for Operators, pay back and ROI for Operators, Roadmaps for deployment at European level)
  - Deliver conclusions on the Traction TD as a contribution to Shift2Rail macro KPIs achievements

### **New Traction converter for HST application (TRL7)**

The work is divided in working-blocks:

- Definition of real trains to be used as test trains for the integration of the demonstrators: Description of the train, characteristics, ownership, method of integration (permanent or transitory modifications), maximum time for the testing and number of demonstrators to be integrated. During the project phase, a concrete high-speed application will be selected depending on the results of the project and the availability of the demonstration.



- Definition of Validation Parameters and Test Procedures to fully validate a functional prototype (TRL7): The validation plan will include all the testing procedures to verify the performance of the independently rotating wheel new traction system. It will also be meant to contrast the expected targets defined in the project phase with the results of the experimental validation.
- Integration of a fully functional prototype (TRL7) of a low-floor, independently-rotating-wheel distributed traction system for a HST: This demonstrator will specially focus on the motors which will be designed to respect the low floor concept. “Factory” and static tests will be performed to verify that the integration is successful.
- Demonstration: The final demonstration and assessment of a low-floor, independently-rotating-wheel distributed traction system TRL7 prototype for a HST train will be done
- Assessment: All the HST SPD technical improvements results will be gathered and added the economic and marketing layers.

#### ***1.5.1.4. Impact of the Traction Systems Demonstrator***

The most significant quantitative benefits brought by the new technologies, methodologies and simulation tools developed within the Traction TD tasks are:

##### **Life Cycle Costs**

- **Reduction in capital costs** (Rolling Stock): Reduction of the traction system validation and certification costs by around 40% through simplification, harmonisation of rules and shifting from "on site" certification tests to simulations and/or static bench tests
- **Reduction in maintenance costs** (Rolling Stock): high reliability and “maintenance oriented design” components and traction sub-system hardware completed by smart Maintenance onboard software. Contribution to the reduction of the maintenance costs (Rolling Stock) in the range of 5% for the traction drive
- **Reduction in Energy consumption**: higher energy efficiency technologies. Significant weight reductions will also contribute to reduce consumption and thus CO<sub>2</sub> emission to progress on this environmental domain.

##### **Train or line Capacity**

- **Passengers per Meter of Train Length**: New compact and lighter Traction components associated to a “capacity oriented” train architecture will allow an increase in the number of seats and passengers.
- **Reduction of noise emissions** in the range of 5 dB(A) mainly by reducing cooling noise of the Traction case and motors.

##### **Reliability**

- **Reduction in the number of In-service failures**: High reliability and availability on components and sub-systems will be at the heart of the design of new solutions. Reduction in the number of in-service failures per million km by about 25 %



Those specific benefits will have a major impact and contribution in the Shift2Rail system level KPIs highlighted in the Master Plan. Local impact progress will be assessed first at the Traction TD level via (TRL4) up to (TRL7) demonstrations on Technology Demonstrators. Finally, progress contribution at system level for each of the three market segments (high-speed passenger transport, regional passenger transport, urban/suburban passenger transport) will be quantified.

Both inputs and impacts on markets, standards and barriers will be evaluated and taken into account:

- Detailed Market needs per segment to secure that new solutions are providing answers to the evolution of needs at the 2020 horizon.
- Standards and regulation (including TSI) in order to allow new technologies to be implemented including, for example, more virtual validation and certification.
- Barriers (technical, cultural, business rules) identification and mitigation to help the acceptance of the new solutions by all the stakeholders.

The deployment of new solutions on markets should start very quickly after the end of the expected demonstrations on Urban, Regional and HST.

### **Strategic impact**

In the following section, a summary of the strategic impacts produced by the implementation of the TD results and discoveries is given. This is organised along three main aspects: the support to the competitiveness of the EU industry, the compliance with the EU strategic objectives, and the degree of maturity of the solutions envisaged to be realised and put into practice in the railway sector. This is expected to provide an overview of the effects generated at larger scale by the application of the TD results.

Strategic Aspect	Key Contribution from the TD
Support the competitiveness of the EU industry	<ul style="list-style-type: none"> <li>• Keep the European Traction industry in the technology race versus Japanese who have taken some advance in SiC technology and applications</li> <li>• Develop high added value and competitiveness of Traction industry including new design methodologies and tools (noise, reliability, virtual certification tasks), validation of Traction components or systems</li> <li>• Develop and promote European/ Worldwide standards on new SiC semi-conductors Technology</li> <li>• Harmonise and simplify Traction certification process to decrease cost and duration via virtual certification drastic progress</li> <li>• Provide technological leadership supported by a combination of radical innovation (e-transformer, high speed motors, independently-rotating-wheel distributed traction system)</li> <li>• Proof tangible benefits for the end user: <ul style="list-style-type: none"> <li>○ Increase of operational reliability (less service disruptions) through more robust and validated Traction systems</li> <li>○ Support Train capacity increase because of lighter and smaller Traction equipment, Traction new solution for low floor HST.</li> <li>○ LCC reduction (through virtual certification, higher reliability, lower energy consumption)</li> <li>○ Additional advanced maintenance services through high added value functionalities like traction system and components remote failure diagnostic and health monitoring</li> </ul> </li> </ul>
Compliance with EU objectives	<ul style="list-style-type: none"> <li>• Promotion of modal shift: A big impact brought by the implementation of these new technologies towards better train punctuality and adding new accessibility to train with “at same level” between station platforms and train floor.</li> <li>• Support to capacity increase: as mentioned above this is allowed by more flexible traction component implementation in the train and less service disruptions.</li> <li>• Greening of transport through energy consumption reduction thanks to high efficiency components like e-transformers and SiC based traction inverters</li> </ul>
Degree of maturity of the envisaged solutions	<p>Currently most of the proposed technologies are at low TRL levels. At the end of Shif2Rail it is targeted that the successful concepts are brought to TRL 7 (prototype demonstration in real operational environment). In parallel to Technical developments, marketing studies, norms and regulation work will prepare a favourable environment to have economic viable new solutions for industry and operators.</p>

#### **1.5.1.5. Implementation of the work programme**

The following sequence of tasks is envisaged with a view to achieving the objectives of the TD. It is foreseen that the activities should reach TRL 7, with the development of three physical demonstrators on metro, regional and high-speed train (HST), at least on test tracks. The Traction TD will take into account linked TDs work like TCMS, Running Gear and Brakes.

##### **Task 1.1.1 – Top level requirements (up to TRL 3):**

The objective is to understand, specify and agree and update the operational and maintenance needs of operators and infrastructure managers to secure train operators needs for the year 2020 and

beyond. With this input the top level requirements of the next generation traction systems are described for a range of applications covering tramway, metro, sub-urban, regional and high-speed trains. Market segments specific requirements profiles are developed that serve as input for the traction demonstrators. The task also includes an update of technologies transfers along the project duration.

Vehicle manufacturers will collaborate in this task, in close collaboration with EU users/operators and the Shift2Rail cross-cutting activities.

Members will contribute to describing needs and building the vision for future 2020 Traction systems for new and refurbishment markets.

In particular, Members will contribute to describing needs on:

- LCC aspects, covering traction weight and volume savings; operation cost reductions (including energy and maintenance costs)
- maintenance oriented design, including digital technologies to achieve a more efficient maintenance policy
- virtual certification, standardisation of components & qualification to reduce authorisation costs, market analysis and eco-labelling needs
- comfort: noise reduction including train in parking mode and acceleration and focus on Traction cooling systems (parking, stand still and pass-by modes) and tonal noise (acceleration and parking);

Members will focus on the needs and markets of different segments: Metro, Regional, sub-urban, HST, and tramways. Technical and economic targets will be detailed in line with S2R general targets per train segment.

The work to be done involves: State-of-the-art of traction systems, market and economic studies, requirement specifications on system and component level, top level concept and interfaces with limited collaboration between Members on their respective applications, eco labeling on energy, noise & recycling (LCA).

#### **Task 1.1.2 – Development of lab prototypes (up to TRL 4/5)**

The task includes the development of traction systems and components for tramway, metro, sub-urban, regional, HST, the integration and test of critical technology, development of hardware and software for the prototypes, the lab tests, scale one mock-up validations, and the relevant regulatory and market analyses.

The prototypes will be developed with the help of methodologies and tools developed in other tasks, such as 1.1.3, 1.1.4 and 1.1.5. Some prototypes will be taken to higher TRL demonstration in T1.1.7.

Vehicle manufacturers will contribute each on a different application developed up to TRL4-5.

On Urban/Sub-urban Traction, complete SiC based power trains for Metro, Tramway and Sub-urban prototypes will be developed.

On Regional Traction, a complete SiC based power train and a e-transformer elements will be developed.

On HST Traction, a low-floor system for an independently rotating wheel architecture will be developed.

Members will support pre-studies on:

- energy savings: Hybrid technologies via energy storage, energetic optimisation including, braking energy recovery solutions,
- maintenance: spare parts obsolescence management will be taken into account at design stage.
- feasibility of traction upgrade at mid-life renewal thanks to interfaces standardisation will be considered .
- evaluate the impact of potential fast rotating electric motors on noise, bearings aging.
- support more connectivity for Traction, i.e. transmission of maintenance or energy detailed data from the Traction sub-system or components.
- support component and system lab tests

All relevant latest scientific, technical progress, results and deliverables from other Traction TD “support” tasks will be used in this task and applied on components and sub-system developments.

### ***Urban/Sub-Urban Traction System & Components development***

Several members will contribute to Urban/Sub-Urban Traction System & Components development, with different applications.

Tramway: A new traction architecture for tramway application will be developed

#### **Architecture, concepts, interfaces**

From top level requirements, the suitable performance and architectures of a new generation of converter will be defined, based on SiC material. An overall system optimisation including innovative mechanical integration concepts is targeted.

#### **Integration and test of critical technology**

The integration challenges into tramway applications will be studied and appropriate solutions derived including control algorithms, semiconductor gate drive circuit, EMI/EMC aspect, advanced cooling systems, noise level mastering. The impact of the fast switching characteristics on adjacent traction components, the isolation system of motors and transformers will be considered.

#### **Development of prototypes (HW and SW)**

A converter and the control system will be developed and a prototype for tramway applications will be built.

**Lab-tests**

The tramway traction converter will be validated and tested up to TRL4. The lab tests will focus on the expected converter performances including reliability. Typical requirements valid for the railway domain including the environmental conditions for vehicles will be considered for the lab tests.

**Validations on static test bench**

The converter will be validated and tested on the overall system performance including weight and energy savings of the traction components like motor and filter components.

Metro: A traction sub-system and components will be developed, integrated, tested and validated. It includes Power cores, drivers, power electronics, transformers, inductive components and control strategies. A functional mock-ups & prototypes will be carried out.

**The Architecture, concepts, interfaces** of new architectures will be defined and described.

**Integration and test of critical technology**

Some issues related to the integration of new SiC components in metro trains will be solved, new control strategies, new drivers and new control hardware developed and integration tests made.

**Development of prototypes (HW and SW)**

Components prototypes, medium frequency transformers and inductive components will be developed and a fully functional prototype of SiC based traction converter for metro application will be built

**Lab-tests**

Metro prototypes will be validated. This validation includes the research unit tests at component level as well as the validation of the power cores, medium frequency transformers and inductive components.

**Validations on static test bench**

Combination testing, integration on combination testing scenarios and validation on test bench of the metro converter prototypes for demonstration platform will be carried out.

Sub-urban: A new traction architecture for sub-urban trains will be developed, along with prototypes of motor converter, traction front-end, control electronics, packaging, and motor.

**Architecture, concepts, interfaces**

The concept of the sub-urban traction system will be elaborated after architecture, interfaces, basic concept alternatives and design principles description. Criticality, and cost/benefit will be evaluated.

**Integration and test of critical technology**

The concept design of power cores integrating the new generation of semiconductor modules and further critical technologies (drivers, control electronics, advanced cooling, advanced passives) for sub-urban applications will be developed and improved. Simulation and testing methods are extended to design and will help to verify robustness, fast switching, compact and more energy efficient traction sub-system or components. Integration challenges with the entire traction sub-system will be studied.

#### **Development of prototypes (HW and SW)**

The traction converter prototype for sub-urban applications based on the conceptual design and further components of the traction system will be developed.

#### **Lab-tests**

Successive integration test in the lab will be performed in the context of the sub-urban application and finally tests the critical functions of the whole prototype.

#### **Validations on static test bench**

The sub-urban converter prototype with the traction motor and other components will be validated in a combined lab test.

**Integration and test of critical technology** work will take place where Then **Development of prototypes (HW and SW)** will be done.

Some **Lab-tests** will be performed. The task will end with **validations on static test bench**

### ***Regional Traction System & Component development***

#### **Architecture, concepts and interfaces:**

- for the E-Transformer, the following studies will be done: train architecture, RAMS, pre-study of power structure, prototype, control, SiC packs High Voltage and Low Voltage, power part development, characterisation of semi-conductor.
- for SiC Traction, the following studies will be done: external interfaces definition, power Train.

Then **Development of prototypes (HW and SW)** will be done:

- On E-transfo: realisation of one or two stages of e-transfo.
- For SiC Traction: optimised traction components development, first tests with functional mock-up to validate the control strategies, the drivers, and the control hardware, traction test bench development.

The task will end with validations on static test bench.

- On E-transfo it will be: integration of equipment and testing of complete system.
- For SiC Traction: integration of equipment in test-bench, investigation and validation tests (functional, electrical, thermal, noise and EMC test report)

### ***HST Traction System & Component development***

A real-scale independently rotating wheel architecture prototype on a HST will be developed, manufactured and tested:

- development of a prototype single wheel motor integrated into a bogie structure (mechanical integration demonstrator).
- low-floor traction system for an independently rotating wheel architecture (single axle or double axle), with passive guiding and direct wheel-drive, to be integrated in a HST.

The output will be:

A single wheel motor ready to be integrated into a bogie structure which will allow a fully walk-through lower floor.

The support of an HST Operator is expected in this area.

### ***Upstream Market analysis / regulation analysis / market viability***

Apart from technical work and developments, Market needs, standards studies will be done on the different targeted applications. Risks and barriers will be identified, proposals will be done to mitigate the different risks, remove barriers that hinder new technology to enter the markets. ROI file elements for all markets will be evaluated including R&D Costs, future potential product cost, time to market.

#### **Task 1.1.3- Tools and methodologies for reduced traction noise and EMI (up to TRL 3):**

The objective of this task is to reduce the acoustic and electromagnetic emission of a traction system, developing methodologies and simulation tools able to predict the emissions during the development phases of the or traction components and sub-system in general but also for the SiC based traction system developed in this TD.

Members will collaborate in this task on electromagnetic forces/noise reduction.

The mechanisms of electromagnetic noise sources will be described and models developed and validated, reduction measures for relevant traction components defined, and results by simulation and testing verified.

Work on Aeroacoustic noise reduction and specific work on EMI emission and susceptibility evolution will be carried out by members

New solutions for controlling the noise levels and tonal noise (acoustic and electromagnetic) for standstill, acceleration and pass-by phases of trains will be found using a train-track virtual model for various operating conditions simulations. Work on optimisation of noise and energy consumption of parked trains will be done. Investigations of operation/park modes, component studies (for example fan technology) are planned.





#### **Task 1.1.4 – Tools and methodologies for increased reliability, availability and smart maintenance (up to TRL 3/4)**

The general objective of this task is to increase reliability and availability of traction components and to develop advanced maintenance methodologies and software tools. Increasing reliability and availability will not only drop Life Cycle Cost but also boost safety and allows the operators to run trains according to schedule. Members will collaborate in this task to Improve the knowledge of mission profiles, improve knowledge of failure mechanisms of critical power (traction) components, develop concepts and architectures for high availability, define a methodology for life cycle estimation, formulate design guidelines, evaluate sensor technology and concepts from other industries and propose transfer to rail, improve methodology for reliability stress tests, develop remote diagnostic and health monitoring of traction systems and components and propose predictive maintenance principles. All this work will be applied on T1.1.2 developments.

A combination of co-operations will take place and Members will work as follow:

- Develop concepts and architectures for high availability
- Develop a methodology for life cycle estimation of critical power (traction) electronics components in real operational conditions
- Develop models for reliability and lifetime prediction of critical components and formulate design guideline
- Evaluate sensor technology and concept from other industries and propose transfer to rail (reliability, availability, cost)
- Improve methodology for reliability stress tests
- Develop remote diagnostics and health monitoring of traction systems and components
- Provide a proof of concept for remote diagnostics & health monitoring and develop the predictive maintenance principles

Members will finally apply Reliability/Availability effectiveness demonstration on the high TRL technology demonstrators

Members will:

- Provide data and analysis on reliability (including power components better knowledge on the ageing) and safety
- Collaborate on in Real-time diagnosis and predictive maintenance of the traction system with digital train-to-ground communication
- Participate to Smart Maintenance developments on Traction components, support digitalisation (including remote data analysis) and Condition based maintenance (CBM) using existing sensors. Cooperation with maintenance depots activities is envisaged and a TRL5-7 demonstration is planned.



### **Task 1.1.5 – Requirements, specifications & developments for virtual validation and certification (up to TRL 4/5)**

Traction certification is currently considered a too costly and too long process and could be optimised. If certification and validation tests could be transferred from test ring to static test bench or pure numerical simulation tests, major cost and time savings could be achieved. The task main activity is to develop methods and simulation tools for improved design, validation and certification of traction components and subsystems.

Members will collaborate in this task on establishing a state of the art and gap analysis, providing the requirement and concept specification including interfaces with vehicle authorisation and propose methodologies/ standards & regulation improvement when needed.

Members will:

- Define simulation scope & domains, develop and improve models, improve the static test bench to reduce on trains tests.
- Assess the energy improvement by means of simulations based on the traction parameters evaluated by the TD-responsible. This is carried out for the use cases high speed, regional and sub urban.
- Quantify the virtual validation and certification effectiveness benefits on the Traction TD demonstration task, with one of them providing a (TRL 4 to TRL 5) Hardware in the loop and proof of concept for testing and virtual certification.
- Collaborate to Standards & certification (upstream standardisation phase). They will participate, support and/or develop new methodologies and tool to increase virtual validation and certification including Hardware In the Loop (HIL) methodology to evaluate the impact of new solutions on the behaviour of the traction system concerning EMC

Possible contributions of Operators, ERA and/or National Safety Agencies and other Associates could be needed.

### **Task 1.1.6 – Supply standardisation for key components & Technology transfer (up to TRL 5/6)**

The objective is to deliver pre-standardisation for key components, eventually participate to standardisation of new key components, update the relevant new technologies as well as access and transfer research results from on-going and forthcoming European research projects out of different industries, and also from research programme outside of Europe.

Members will collaborate in this task to define set-up for technology research and transfer, perform “technology research” disseminate technology research results in the Traction TD working groups and to support the task of standardisation.

#### **Supply standardisation for key components**

The objective is to increase pre-standardisation and eventually standardisation of new key components delivered from equipment and component manufactures to the rail industry.

This task helps to improved reliability, help second source of semi-conductors and long term availability.

Members will collaborate in this task on new generation power semiconductors standardisation.

Work on standardisation of new electromagnetic and insulation components and materials, new sensor, sensor systems and busses will be carried out

Members will contribute on new standards & regulation for virtual validation and certification

#### Technology research and transfer

The objective is to get an update on the relevant new technologies as well as access and transfer research results. In an initial activity existing new technology and new scientific concepts are identified, accessed, evaluated and compiled for consideration in the various work tasks (build technology intelligence).

Major search fields will be in automotive, aerospace, electrical energy conversion and distribution, automation.

#### **Task 1.1.7 – Integration, demonstration and assessment (up to TRL 6/7)**

The objective of this task is to generate physical demonstrators, integrated in rolling-stock, suitable to perform track tests, either in commercial lines or test rings (TRL7 demonstrator) in Metro, Regional, and High Speed application segments. The final choice between TRL 6 or 7 will depend on constraints relating to certification or authorisation to use the prototypes on commercial lines.

#### Integration

Members will:

- Integrate a fully functional prototype of SiC based traction converter for 1500V in a demonstrator Metro vehicle.
- Integrate a fully functional prototype of SiC based traction converter in a demonstrator Regional vehicle
- Integrate a fully functional prototype of a low-floor independently-rotating-wheelset in a High Speed Train.

Major contribution from operator members should occur in the Regional segment but for Metro and High Speed segments Operational costs of the vehicle during the tests and demo will be covered by a industrial members.

Members will provide an EMU to support Integration of a Medium frequency E-transfo 15 kV based on new SiC semi-cond and to support energy storage on board (hybrid or autonomy mode) experimentation.



### **Demonstration and assessment**

The objective of this task is to demonstrate and assess the results of the outputs of the R&D activities carried out during the project based on the experimental results obtained in the rolling stock tests in the field

The technical results will be used on the conclusion of the Traction TD:

- A (TRL7) fully functional prototype of SiC based traction converter for Regional train will be assessed
- A (TRL7) fully functional prototype of SiC based traction converter for 1500V metro train will be assessed
- Demonstration and assessment report of a low-floor, independently rotating wheel distributed traction system (TRL7) prototype for a HST train will be prepared

### ***Areas for Open Calls***

In addition to the type of expertise and skills proposed by the Members of the S2R JU, the following complementary expertise and skills would be required to carry out the above tasks:

#### **T1.1.1: Top level requirements**

- Prospective: Description of long term objective (ie ERRAC SRRIA) and traction impact, Digitalisation, Big Data and impact on Traction (real time detailed Energy and maintenance data), Description of needs, markets studies, eco-labelling (other operators, consultant,...)

#### **T1.1.2: Development of lab prototypes**

- Research on very high power density permanent magnet motors for wheel mechanical integration. Research Clusters will be helpful on the “Integration and test of critical technology » work, on different scientific and technology work needed on (Regional, Urban, Sub-Urban and Tram) SiC Traction systems and components
- One or more European semi-conductor industrials are needed to check requirements concerning semiconductors, investigate possible realisations of semiconductors for (tramway, sub-urban, ...) application, realize tests, propose realisations of semiconductors aimed at all the range of possible different applications (tram, sub-urban, ...)
- Regulation analysis of future propulsion systems (including SiC but not limited to SiC) could be helpful
- Labs for the scientific and technology work linked with breakthrough technologies ie SiC, Traction sensor wireless communication, energy storage very high power density and energy density, etc.
- Expertise in designing and manufacturing permanent magnet motors



#### T1.1.3: Traction acoustic & EMI noise

- Research Cluster, Academics and/or innovative SMEs could propose methodologies and develop simulation software for electromagnetic noise and cooling noises prediction. Open Calls would be used to complete tools developments for simulation of EMI emission (power converter emission, line modeling, multitrain, etc.).

#### T1.1.4: High reliability & availability

- Semi-conductor industrials and/or research clusters are appreciated to support reliability and availability tasks for of semiconductors and other critical components. Support from a research Cluster is needed on:
  - Health management of power semi-conductors and development of health monitoring approach
  - Investigation of failure mechanisms of new SiC based power components (safe operating area, MTBF, etc.)
- Tools and methodologies for increased reliability and availability & Smart Maintenance:
- Labs to progress on data synthesis and messages to transmit via train connectivity systems (from parts to global line, including remote diagnosis and maintenance)

#### T1.1.5: Virtual certification

- Some Research Cluster would be helpful in various simulation domains including EMC and for the development of Hardware in the Loop environment for testing and diagnosis of propulsion systems. Contribution of ERA and/or National Safety Agencies could be also needed.
- ERA, NSAs to work on evolution of regulations/ process of certification
- Labs to progress on physical understanding of phenomena and simulation description (ex: EMC, interaction trains/infrastructure/signalling)

#### T1.1.6 Supply standardisation for key components

- TSI follow up with ad hoc external group, ie: Traction specific topics, energy,...
- improve the results of work in the field of storage technique (standardisation, optimisation, ...)

### 1.5.1.6. Planning and budget:

TDs	TASKS	TRL	2015	2016	2017	2018	2019	2020	2021
<b>TD1.1</b>	<b>TRACTION</b>								
	1.1.1 Top level requirements	3	■	■	■	■	■	■	■
	1.1.2 Development of lab prototypes	4/5	■	■	■	■	■	■	■
	1.1.3 Traction acoustic & EMI noise	3	■	■	■	■	■	■	■
	1.1.4 High reliability & availability	3/4	■	■	■	■	■	■	■
	1.1.5 Virtual certif. & homologat.	4/5		■	■	■	■	■	■
	1.1.6 Standardisation for key components & Tech. Transfer	5/6		■	■	■	■	■	■
	1.1.7 Demonstration & assessment	6/7				■	■	■	■

The estimated total budget for Traction TD is around 75,1M €.

## 1.5.2. TD1.2 Train Control and Monitoring System Demonstrator

### 1.5.2.1. Concept and objectives of the TCMS Demonstrator

The Train Control and Monitoring System (TCMS) is the brain and the communications backbone of the train, which has some essential roles on vehicle performance:

- Integrates and manages all on-board information. Makes train control decisions considering the global state;
- Performs communication between equipment, between vehicles, between consists and between train and ground (except signalling related, up to now), and;
- Is the essential actor in the integration and interaction between different subsystems of the train.

Most currently deployed TCMS are based on the IEC-61375 TCN standard which was originally established in its first version in the late 1990s. The network is composed of two buses: The multifunction vehicle bus (MVB) and the Wire Train Bus (WTB).

This technology, still in use, is very much specific to railways. Therefore few or no concepts or hardware from other sectors can be reused. The specific hardware and software make MVB and WTB expensive, while their relatively poor performance (1.5 MBit/sec. and 1.0 MBit/sec. respectively) means a bottleneck for deploying new demanding functions onboard.

So the information transmission possibilities of existing standard TCMS network for train control functions are quite limited, and the increase in information volumes and the introduction of new diagnostics and passenger oriented services requires today an additional network often based on Ethernet. The IEC TC9 Working Group 43 has been working on a new revision of IEC-61375, which includes, for the first time, two Ethernet based buses: The Ethernet consist network (ECN) as a replacement for MVB and the Ethernet Train Backbone (ETB) as a replacement for WTB. Although Ethernet brings higher throughput and other benefits like reduced cost, some important weak points remain in TCMS systems.

Current practice in industry involves a standard physical TCMS network for train control functions and an additional network (often based on Ethernet) for other functions. This means a considerable amount of on-board cables and therefore weight and complexity. To make it worse, current TCMS solutions achieve certain safety levels (SIL 2) which is not enough to move train safety lines (i.e. more cabling) to pure data transmission through the communication buses due to their safety-critical mission (SIL 4).

Today, coupled trains have become an important bottleneck in terms of performance. Transmission through the auto-coupler is notably impaired by the contact nature and the performance of ETB is much lower. Wireless communications are already a reality, but there are no on-board applications in railways (except internet connection for passengers). Many uncertainties concerning technology, and safety and security aspects block any attempt to use them.

Even if the communication is possible, applications on both sides of the coupling are many times incompatible, due to different implementations, versions, or retrofitting. Self-configuring adaptive solutions providing plug-and-play features through a functional open coupling may solve this issue.

However, the final step is providing a virtual coupling, where the consists run together, as coupled, but without any physical connection, thus consists manufactured by different companies and with different interfaces could be virtually coupled, driven together by the leading cabin and sharing the same traffic slot. Pushing the concept to its limit, it would be possible to couple and uncouple consists on-the-fly (i.e. while both consists moving or even cruising) and increase significantly the capacity of the line by making long chains of virtually coupled trains. Although this concept will be developed in the Innovation Programme 2 (TD2.8 – Virtually Coupled Train Sets) the concerned TCMS infrastructure is targeted by this TD.

Successful integration of subsystems and commissioning of TCMS require huge efforts and take an extremely long time due to the lack of standardised application profiles, appropriate architectures and simulation and testing frameworks. The increasing number of new services and applications brings several modifications of the TCMS implemented functions along the train's life, implying re-commissioning the TCMS every time. The current standard in TCMS authorisation is largely based on FMEA analysis based on the TCMS architecture and extensive testing on laboratory setups as well as on the real train. Especially the testing on the train is a very high effort and takes lots of time – often delaying the start of service operation for entire fleets significantly. This situation can be significantly improved also by developing an authorisation process based on simulation.

In 2010, the operators analysed the future needs for high speed rolling stock, providing some recommendations for the TCMS<sup>2</sup>:

- Integration of functions may reduce the weight of trains by reducing the amount of wiring and controllers for each component.
- To increase reliability and avoid electrical system errors, electrical coupling using wireless data transmission could be introduced avoiding physical intervention.

---

<sup>2</sup> International Union of Railways. Necessities for future high speed rolling stock. Technical report, 2010.

Thus six main innovations are envisaged to develop within the ambit of this initiative:

- Virtual certification;
- Function distribution based architecture;
- Driven-by-data;
- Wireless communications for TCMS (including CCTV);
- Functional open coupling, and;
- Support for virtual coupling.

The next generation of TCMS with **wireless** capabilities, full “**driven-by-data**” command, **seamless coupling, enhanced throughput** and reliability, and new architecture based on **distributed functions** while supporting **safety** and **security** functionalities, **improved sensing**, supporting easier **authorisation** and **self-configuration** will overcome today’s limitations.

A complete new TCMS architecture, **mixing wired and wireless** communications, enhanced **interoperability**, and “**driven-by-data**” concept, will be developed. The needed work includes the definition of **new protocols** and **application profiles**, standardised software framework supporting **reallocation of functions**, the definition and validation of the wireless technology including the ground connection, the definition, design and manufacturing of new devices (routers, repeaters, sensors, end-devices, gateways) while taking into account **safety** and **security** aspects, which may imply the design or use of specific encryption hardware.

On the other hand, both the virtual coupling together with the functional open coupling concepts will mean the **complete interoperability** from the TCMS perspective, while paving the way for a new way of operating trains by creating **chains of virtually coupled trains**, which can be attached and detached dynamically according to the service needs and available slots.

**Technological output to be delivered by this TD:**

New generation TCMS architectures and components with wireless capabilities, enhanced throughput, safety and security functionalities, supporting distributed function execution and mechanisms for easier authorisation will be delivered to the SDPs.



**Specific achievements to be delivered by this TD:**

1. Reduce the amount and weight of cabling for train control by half (Save 10 km of cable in each 20 m railcar). Reduce the space used by electronics hardware by 25%
2. Ability to implement SIL4 functions in the TCMS to perform additional safety-critical tasks.
3. Increase in the availability of trains related to the functioning of train control and monitoring by 50%
4. Ability to couple any pair of multiple unit of different types, a feature currently totally non-existent and can significantly increase line capacity
5. Support technologically the development of the “virtual coupling” concept, which can dramatically increase the capacity of lines
6. Reduce cost, time and effort in project engineering, integration and authorisation phases by 50%

The following table shows how the proposed activity will contribute to the achievement of the Shift2Rail objectives as stated in the Shift2Rail Master Plan:

**Table 2: Objectives and deliverables of the TD**

S2R Objectives	TD Objectives	Practical contribution (how)
Improved services and customer quality	Increased availability	Increased reliability and less service disruptions thanks to wireless TCMS and new architectures based on the functional distribution concept.
Reduced system costs	Reduction of manufacturing, commissioning, operating and maintenance costs	Less but more reliable components integrating several functions (incl. safety critical ones). Easier integration, testing, validation and retrofitting / upgrading.
Simplified business processes	Seamless coupling. Integration of SIL4 functions. Simplified authorisation. Wireless TCMS. Contribution to the affected standard series.	More flexible and reliable interoperable coupling procedures. Standardised testing platform allowing virtual certification. Simpler connections through wireless networks. Standardisation oriented work.
Enhanced interoperability	Seamless coupling. Support of the IP2 “Virtual Coupling” paradigm. Wireless TCMS including train-to-ground.	Radio based TCMS including a standardised train-to-ground link, new architectures based on the functional distribution concept and standardised application profiles.

### **1.5.2.2. Technical ambition of the TCMS Demonstrator**

At the beginning of the nineties, the widespread introduction of digital devices on board of trains brought the need to interconnect them, pushing companies in developing or using many independent solutions. Several implementations about train busses started appearing on board trains, resulting in a number of not interoperable products. This was hindering the possibility to

couple vehicles from different manufacturers, as it is requested in international operations, due to their non-compatible communication networks.

To solve such problems, IEC (International Electro-technical Committee) and UIC (International Union of Railways) started a standardisation work, supported by the industry, which finally brought in 1999 the approval of the IEC-61375 standard for a “Train Communication Network” or TCN and the UIC leaflets UIC556 "Information transmission in the train (train bus) and UIC558 “Remote control and data cable” that specify the application data exchange using TCN. Since then, TCN has been deployed in thousands of rail vehicles and trains worldwide, becoming the reference networking platform for many devices and applications.

This technology, still in use, is very much specific to railways. Therefore few or no concepts or hardware from other sectors can be reused. The specific hardware and software make MVB and WTB expensive, while their relatively poor performance (1.5 MBit/sec. and 1.0 MBit/sec. respectively) means a bottleneck for deploying new demanding systems onboard.

So the information transmission possibilities of existing standard TCMS network for train control functions are quite limited, and the increase in information volumes and the introduction of new functions and passenger oriented services requires today an additional network often based on Ethernet.

The CCTV (Closed Circuit Tele Vision) systems are more and more deployed in the trains as security systems. In addition operators provide new powerful infotainment (information & entertainment) services to the passengers based on TFTs, contents servers or powerful displays. VoIP (Voice over IP) communications onboard or train to ground, real-time services to ground servers (monitoring, diagnosis, etc.), onboard internet access, etc. are implemented on the trains as standard services. This kind of services and the devices of these systems demand much bandwidth of the communication network.

Obviously these services cannot be based on MVB/ WTB buses, so in practice an additional Ethernet bus is mounted to cover them.

**Figure 6: Current TCMS**

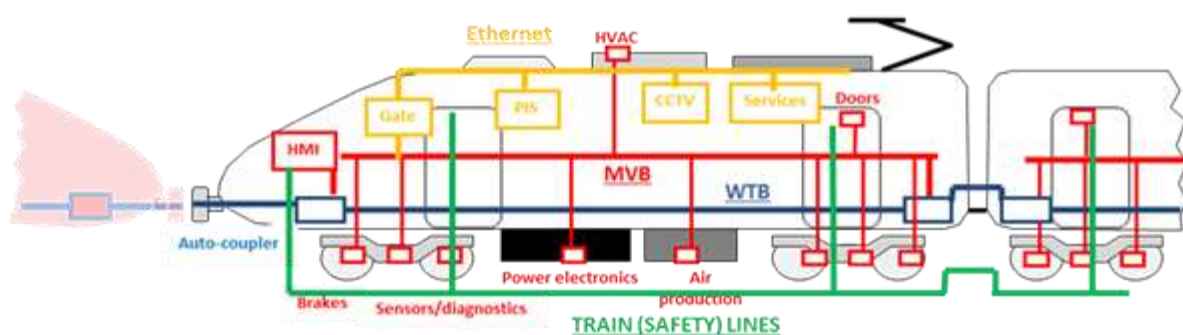

Although Ethernet brings higher throughput and other benefits like reduced material cost, some important weak points remain in TCMS systems with this architecture:

- It does not manage safety critical communications: Train safety lines are required;
- Integration, debugging and (re)commissioning still require too much time and money, impairing the competitiveness of the railway industry;
- Processing architecture not optimal for compatibility, reliability and safety;
- Train-to-train communication performance is poor;
- A big amount of cabling is needed, whose side effect is high cost and weight;
- TCMS is responsible for approximately 25% of the service disruptions caused by train failures, due to hardware (cabling, connectors, boards...) faults or software bugs;
- Non-standard train-to-ground communication blocking the deployment of new interoperable functions (e.g. energy metering).

Beside the industrial evolution and the tasks carried out within the standardisation group IEC TC9 WG43, a number of activities have been carried out in the last years, and some of those were research projects financed by the European Commission; all those initiatives contributed to the evolution of TCMS so far. A summary is reported in the following table:

**Table 3: Past initiatives**

Project	Input
<b>IEC-TC9-WG22 (1989-1999)</b>	Protocol specification for a Train Communication Network (TCN)
<b>FP5 TrainCom (2000 – 2003)</b>	Integration of railway and ICT to link train and ground systems, allowing to develop new interoperable applications
<b>FP6 ModTrain (2004 – 2007)</b>	Subproject ModControl: Functional breakdown structure and functional interface specification of subsystems.
<b>FP6 InteGRail (2005 – 2008)</b>	Subproject ICOM: Train to ground wireless communication architecture and concepts. IPv6.
<b>FP7 Marathon (2011 – 2014)</b>	Radio link between locomotives.

#### **Development towards near future incremental innovation:**

Today Fast Ethernet with a bandwidth of 100 MBit/s and perspective of up to 10 GBit/s is more and more deployed in factory automation and migrated to railways through the new ETB and ECN buses. This appears to be a good improvement as a follow-up of WTB and MVB.

The main four communication paradigms of TCMS should be retained in a future train communication system:

- The hierarchical structure of train level and vehicle level can be reflected with the addressing scheme and the separation of data flows in different subnets;
- The separation of deterministic process data and event driven message data can be implemented by Virtual LAN (VLAN), Quality of Service (QoS) and Virtual Private Networks (VPN);
- The auto configuration of the WTB, which also uses point-to-point connections during inauguration of the train, can be adapted to a switched Ethernet;
- The device-independent addressing of functions can be assisted by Internet technologies like static and dynamic name servers.

**Figure 7: Communication Network based on IP/Ethernet (simplified)**

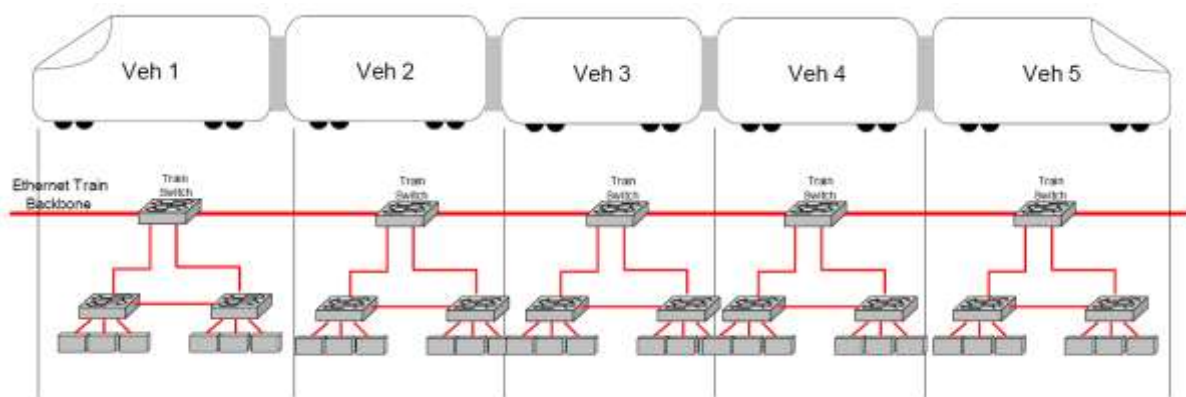

The Ethernet technology is accompanied by Internet Protocols (IP), that are freely available, absolutely open, proven in a tremendous amount of applications and nowadays can be found in more or less every system, e.g. office Personal Computers (PC), Personal Digital Assistant (PDA), internet server or control systems. This allows a seamless integration of trains into the operator infrastructure including control centers, workshops and offices, through an appropriate and standardised train-to-ground link.

Ethernet can be deployed as an "all in one" solution or as well in parallel to MVB and WTB, which might also be well suited to retrofitting existing train fleets. But from the cost and maintenance perspectives, it might be better to use only one Ethernet based communication system.

In practice, it can be expected that there is a smooth migration from today's systems to Ethernet based IP systems, and both will be deployed in parallel for quite some time. This is also reflected in the standardisation work of IEC, which opened the document structure of the TCN standard to include new vehicle (consist) and train networks.

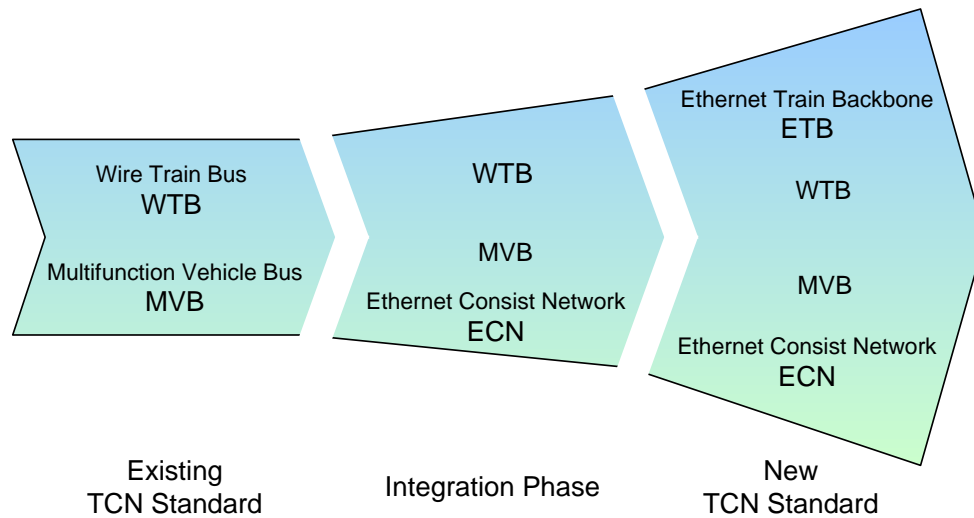
**Figure 8: TCN standard evolution**

The definition of abstract services and interfaces facilitates the migration from today's TCN to a much more powerful Train Communication Network based on Ethernet (ECN+ETB).

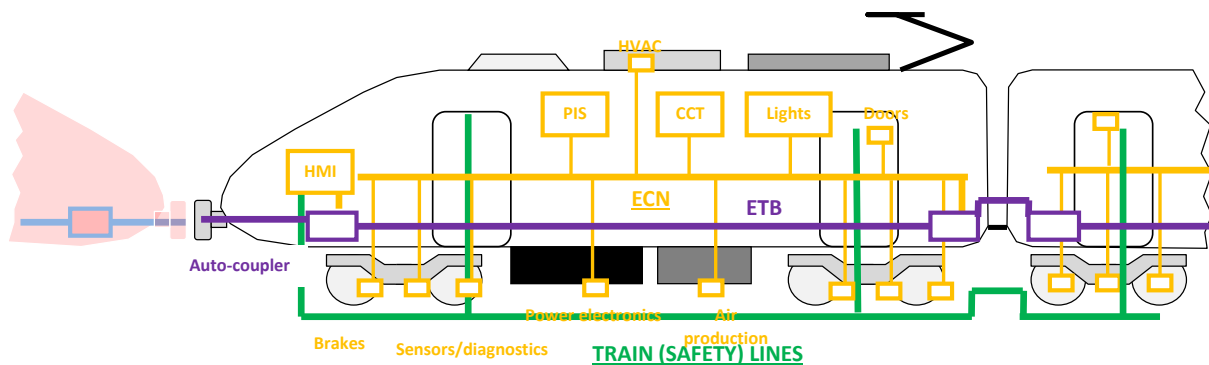
**Figure 9: Modern TCN architecture based on Ethernet**

This new bus may avoid the current duplication and partly or totally overcome some drawbacks of existing technology, due to:

- Higher throughput;
- More standard components, lower cost, and;
- Less cables than before.

Still, even when this improved architecture is developed and implemented, some big limitations will remain, such as:

- Train safety line will be required;
- Still big amount of cabling is needed meaning cost and weight, among other implications;

- Processing reliability can be improved, or;
- Safety critical functions higher than SIL2 are still not considered.

Transmission through the auto-coupler is notably impaired by the contact nature and the performance of ETB is much lower.

Wireless communications are already a reality, but there are no onboard applications in railways (except internet connection for passengers). These technologies are widely used in another industries and applications, but many uncertainties concerning the technology block any attempt to use them, especially safety and security aspects.

Successful integration of subsystems and commissioning of TCMS requires huge efforts and takes an extremely long time due to the lack of standardised application profiles, appropriate architectures and simulation and testing frameworks. The increasing number of new services and applications brings several modifications of the TCMS implemented functions along the train's life, implying re-commissioning the TCMS every time. The current standard in TCMS authorisation is largely based on FMEA analysis based on the TCMS architecture and extensive testing on laboratory setups as well as on the real train. Especially the testing on the train is a very high effort and takes lots of time – often delaying the start of service operation for entire fleets significantly. This situation can be significantly improved also by developing an authorisation process based on simulation and the deployment of plug-and-play concepts.

In addition, all the systems implemented on the trains have their own architecture which is not, always, shared with other systems. The way the systems are integrated is the communication bus, but they maintain their own processing capabilities. If these capabilities are shared and a distributed architecture on the train is defined, with shared processing between different systems, a higher safety and reliability level could be offered.

### **Shift2Rail Vision of the new generation TCMS**

The vision for the new generation of the TCMS proposed in Shift2Rail is based on the expected evolution of fundamental technologies applied to the following:

- Hybrid wireless communications in-car, between vehicles, to ground
- Reduced number of processor which can handle any function from any system
- Architectures prepared for safety critical functions
- Time and cost efficient authorisation and authorisation

The following table summarizes how this TD will progress the state-of-the-art and overcome today’s limitations and difficulties:

**Table 4: Comparison between state-of-the-art and future**

State-of-the-art	New Generation TCMS
Wired TCMS implies a lot of cabling and connectors, and is an important source of failures. Impaired data transmission through the auto-coupler.	Wireless TCMS to reduce cabling and remove the need of a physical contact in the auto-coupler, improving reliability and performance.
TCMS up to SIL2. Safe train lines still needed.	“Drive-by-date” concept: TCMS to provide SIL4 capabilities which allows the integration of safety-critical functions.
Architecture based on numerous CPUs (one or more per subsystem) distributed along the train. Any software change in one of the subsystem requires a new commissioning as applications interface directly with the communication buses.	Architecture based on a functional distribution among a reduced number of CPUs, where each function interfaces the TCMS through a standardised framework; only re-commissioning towards the framework is needed then.
Long and costly on line debugging and commissioning processes. Integration tests require physical presence of subsystem suppliers.	Use of a standardised simulation framework to virtually test and certify the TCMS and its applications, including remote connection through internet and hardware-in-the-loop.
Interoperability is impaired by incompatible coupling vehicles. They not only require having identical physical interfaces, but also require having compatible TCMS application software (i.e. same onboard services, software versions and functions).	The deployment of the wireless TCMS, the standardised functional distribution architecture and the definition of standardised application profiles allow seamless coupling of vehicles.
The train-to-ground link is not standardised so no interoperability is possible for functions requiring such connection (e.g. energy metering). Roll2Rail will propose a standard which will require further implementation and validation.	A standardised train-to-ground communication will assure interoperability and pave the way for the deployment of new functions, transforming the train into an extension of the railway undertaking’s network.

**Figure 10: Future TCMS architecture**

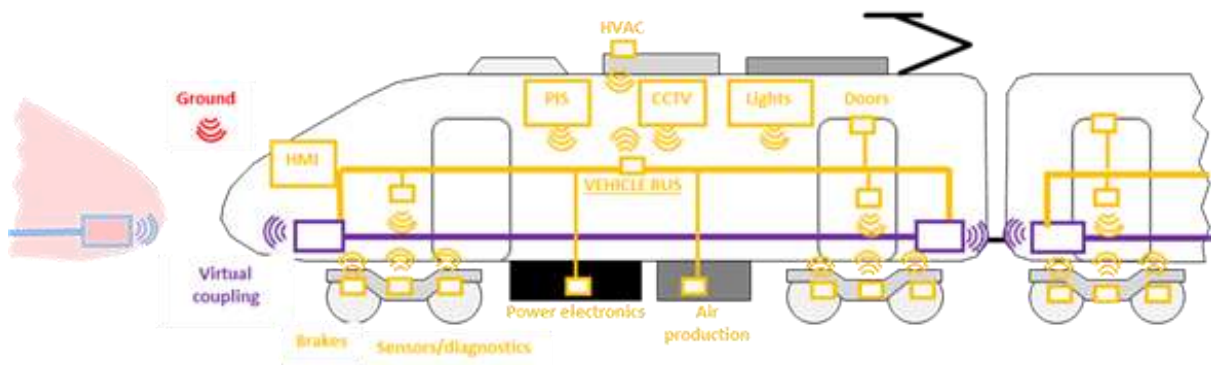

These technologies may be applied separately or combined depending on the features of the application, in order to obtain best results.

The work that is currently in process in TCN-Ethernet will be the main input for the activities envisaged in this TD. In other words, MVB and WTB will be considered as obsolete and not taken into consideration for the proposed activities and studies.

### 1.5.2.3. Specific Demonstration activities and contribution to ITDs/SPDs

The following table summarises the contribution of TD 1.2 TCMS to the different ITDs of Shift2Rail are shown in the following table:

Research Area	Specific Techn. objective	Specification Activities	Demonstrator		Focus of activity
			Market	TRL	
Train Control & Monit. System (TCMS)	Wireless TCMS	Radio techn., architecture and protocols	Metro	6/7	Incorporate wireless technologies to the train communication network solutions (i.e. train backbone, consist network and train to ground communication).
			Regional	6/7	
	Drive-by-data	Architecture, protocols	Metro	6/7	Provide a train-wide communication network for full TCMS support including the replacement of train lines, connecting safety functions up to SIL4 (incl. signalling).
			Regional	5	
	Functional distribution architecture	Specification, architecture and interface definition	Metro	6/7	New architectural concept based on standard framework & application profiles, distributed computing to allow execution of compliant functions on end devices distributed along the vehicle meeting different safety & integrity requirements
			Regional	5	
				6/7	Support the Functional Open Coupling
	Virtual Placing on the Market	Technology definition, protocols and procedures	Generic	6/7	Standardised simulation framework in which all subsystems of the train will be simulated, allowing remote and distributed testing including hardware in-the-loop through heterogeneous communication networks.

### 1.5.2.4. Impact of the TCMS Demonstrator

The most significant quantitative benefits to be obtained in relation to the objectives listed in the previous sections are:

- Reduce the amount and weight of cabling for train control by half (approx. save 10 km of cable in a 20 m car). Reduce the space used by electronics hardware potentially up to 25%;
- Implement SIL4 functions in the TCMS, which will be able then to perform safety-critical tasks (e.g. replacing train lines or integrating signalling communications);
- Increase in the availability of trains related to the functioning of train control and monitoring potentially up to 50%;



- Make possible the coupling between any pair of multiple units of different types, which is a feature currently non-existent and can significantly increase the flexibility to share slots and to manage fleets potentially up to 20%, and;
- Reduce cost, time and effort in the project engineering, implementation, manufacturing and authorisation phases, and later during operation, potentially up to 50%.

Those specific benefits have a major impact in the Shift2Rail system-level KPIs highlighted in the Master Plan. The relative weight of the benefits provided by this work on the overall system-level KPIs for the whole Shift2Rail initiative are estimated (over a total of 100%) as:

1. Increase of capacity (potentially up to 20%): Due to flexible coupling between units and also to the reduction of service disruptions causing line blockages and delays.
2. Increase of operational reliability (potentially up to 50%): Due to new more robust TCMS architectures based on integrated electronics, less cabling and connectors, enhanced validation and debugging concepts, and more flexible processing of information specifically aimed at reliability and the reduction in the number of components.
3. Reduction of life-cycle costs (potentially up to 30%): Due to reduced engineering, testing and authorisation efforts, integration of multiple functions (Inc. safety-critical ones), reduced weight and improved maintenance.

All the principal elements required for rapid market uptake after Shift2Rail have been taken into account. These are:

- Demonstration of technologies in a real operational environment to give credibility and show the benefits clearly;
- Common standard architectures based on interoperable “black-box” concepts, and;
- Orderly development strongly supported in the generation of technical standards which will increase the confidence of future clients and facilitate the quick deployment in new projects.

The technical developments will be standard oriented so the outcome from this TD can be used directly by the concerned standardisation groups and committees like the IEC TC9 WG43 in charge of the IEC 61375 series, whose convenor is aware of the content of the Master Plan and fully supports the proposed work. For example, the IEC 61375-2-6 (Train to Ground Communication) will be fed with the results of the wireless TCMS activities (started within Roll2Rail), making it possible to fulfil the mandate from ERA to finalise the standard within 2 years in order to refer it from the Loc&Pas TSI. The fact that the main contributors to this IEC TC9 WG43 will collaborate in this TD secures the process.

The existence of technical standards will facilitate providers of components and subsystems the development of modular solutions and families of components which will help reduce costs in a relatively short period of time. Providers of all types of equipment connected to the TCMS will need to adapt their interfaces, but this will also be facilitated by the developed technical standards. Considering these facts, it can be expected that between three and five years after Shift2Rail the new developments will be implemented in a high percentage of all new vehicles (estimated in the range 40%-80% of all new projects in Europe and 30%-60% of all new projects world-wide).

A summary of the strategic impacts produced by the implementation of the TD results and discoveries is given in the following table. This is organised along three main aspects: the support to the competitiveness of the EU industry, the compliance with the EU strategic objectives, and the degree of maturity of the solutions envisaged to be realised and to be put into practice in the railway sector. The table provides an overview of the effects generated at larger scale by the application of the TD results.

Strategic Aspect	Key Contribution from the TD
<i>Support the competitiveness of the EU industry</i>	<ul style="list-style-type: none"> <li>• Technological leadership supported by a combination of radical innovation (Wireless Train control, drive-by-data concept, distributed processing for higher reliability ....) and technical standards, setting an effective advantage for the European industry</li> <li>• Tangible benefits for the end user:               <ul style="list-style-type: none"> <li>○ Increase of operational reliability (less service disruptions) through more robust systems based on less physical components, enhanced validation and debugging concepts, and more flexible processing of information.</li> <li>○ Support capacity increase because of trains failing less often in service and also very importantly, making it possible for units to be coupled and decoupled in a very flexible way.</li> <li>○ LCC reduction (through simpler authorisation, lower physical complexity of systems, increased reliability ....).</li> <li>○ Additional performance and service through TCMS covering fail-safe functions, flexible coupling of trains, train-to-train and train-to-ground communications ...</li> </ul> </li> </ul>
<i>Compliance with EU objectives</i>	<ul style="list-style-type: none"> <li>• Promotion of modal shift: A big impact brought by the implementation of these new technologies towards avoiding service disruptions and adding new capabilities</li> <li>• Support to capacity increase: as mentioned above this is allowed by flexible unit coupling and less service disruptions due to lack of operational availability</li> <li>• Greening of transport through energy reduction can be achieved by better integration between subsystems and communications out of the train, as well as optimised consists with flexible coupling</li> </ul>
<i>Degree of maturity of the envisaged solutions</i>	Currently most of the proposed technologies are in TRL 1,2 (Principles observed and the possibility of using them formulated). At the end of Shif2Rail it is expected that the successful concepts are brought to TRL 6 or 7.

### **Interaction with other TDs (of the same IP and/or of the other IPs)**

The main interaction envisaged with other TDs and/or IPs (see Figure 11), both from the point of view of technologies employed and of interaction in performance and objectives are:

- IP1 – TD “Running Gear”: Providing interfacing for wireless sensing and results on use of wireless communication for monitoring key bogie operational parameters (e.g., acceleration, temperature, etc.)
- IP1 – TD “Brakes”: Providing safety critical architectures and protocols interfacing the brake system

- IP2 – TD “Virtual coupling”: TD 1.2 expects to receive requirements from the “Virtual Coupling “ TD, to be considered in the development of the technologies, devices and software. Wireless components realized in TD 1.2 will be then delivered, once tested, to TD2.8 for possible integration and demonstration, if required.
- IP5 – TD “Fully electric propulsion concept”: Providing support to the wireless communication along the freight train.
- I2M Intelligent Traffic Management: TD 1.2 expects to receive requirements from I2M for any train-to-ground and setting the interfaces communication

Moreover, being the TCMS system the central system for processing and communications within the train, some level of interaction will take place with all new developments related to on-board equipment.

**Figure 11: Interaction with other TDs and IPs**

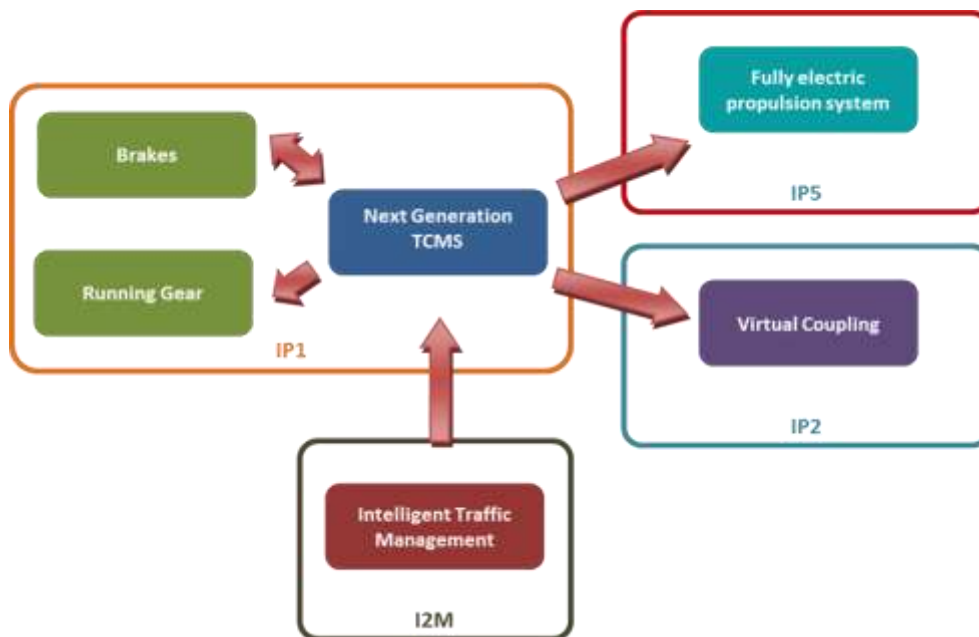

### 1.5.2.5. Implementation of the work programme

A clear methodology has been devised for the organisation of the technical work in the project, in order to maximize the probability that the desired final objectives are met (see Figure 12).

**Figure 12: Methodology**

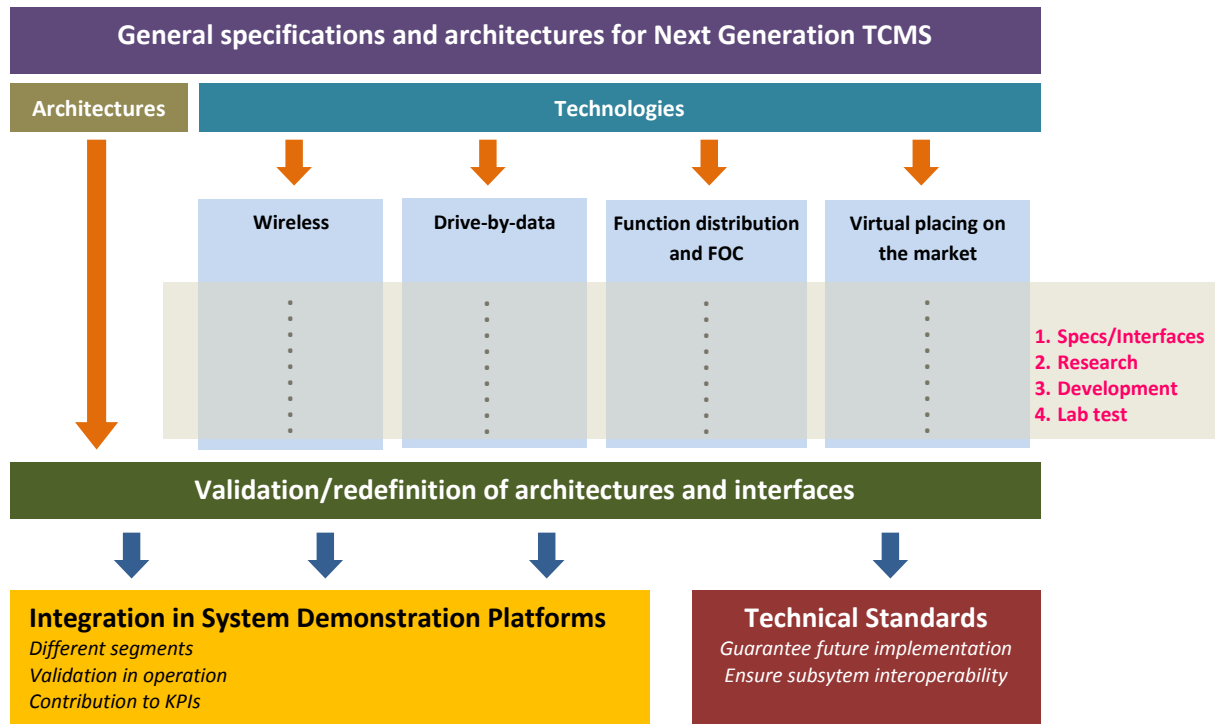

A thorough initial task is proposed looking at general specifications, high-level system architectures and interfaces of the TCMS of the future, considering the expected features of the technologies to be developed and the needs to be covered.

In a second phase, technologies will be individually developed covering the whole development process from basic research, lower level specifications, technology development, prototypes and lab test, leading to results showing their performance and to a full knowledge of these technologies.

After technologies have been developed to their full potential and individually assessed, specifications and architectures at whole system level will be re-assessed and the most adequate solutions for the different types of service and operational conditions will be proposed.

The final tasks that lead to the project results are twofold:

1. On one hand, a number of different TCMS architectures developed in the previous task that bring clear contributions to the Shift2Rail global KPIs will be demonstrated in (2 or 3) System Demonstration Platform
2. On the other hand, technical standards based on the architectures and technologies proposed will be developed in order to promote future deployment. These will also include very detailed definition of interfaces to ensure subsystem interoperability.

Monitoring and key decision making will be managed through the process of gate type reviews at critical milestones throughout the project. A business case approach will be taken throughout the project to focus on the viable target applications.

It is expected that this strategy will effectively guarantee the completion of targets and the deployment of results to the market.

#### **Description of Tasks:**

Shift2Rail members represent a wide part of the vehicle integrators community in Europe, its main suppliers as well as major train operators, which ensures the availability of the relevant complementary expertise and to ensure a wider market uptake of the solutions by the clients.

Specialists in the innovative technologies to be implemented are still required, particularly the ones with experience in sectors other than railways.

The Shift2Rail members will participate in the following priority tasks of the TD1.2 TCMS to achieve the planned final objectives. It will do so in collaboration in order to ensure the availability of the relevant complementary expertise and to ensure a wider market uptake of the solutions.

In general, it is requested for the participation of the European Railway Agency in this activity as advisory body, in order to guarantee that the outcomes are applicable and could be regulated.

Details are provided below:

#### **T1.2.0 – General Specification**

The objective of this task will be to work out the general specifications of next generation TCMS and to generate a high level System Architecture able to distribute specific requirements to the different activities to be carried out later. The following aspects, amongst others, will be covered by the specifications: Standard and wireless coupling of consists, standardised architectures that support data exchange between all functions and components of the network while keeping separation of functions with different safety and security levels, to make sure that the TCMS system will be a flexible and scalable solution for the future. Inputs from IP2 (i.e. TD2.1 and TD2.8) are foreseen to secure that the TCMS communication channels will be able to support the integration of signalling data exchange in the future.

Members will collaborate in this task. They will define the general TCMS use cases and functional, technical, performance, RAMS and security requirements. Related high-level architecture and interface requirements will be specified.

Activities allocated to Open Calls: No Open Calls are expected within this task.

#### **T1.2.1 – Wireless TCMS**

The objective of this task, is to incorporate wireless technologies to the train communication network solutions. Research has started within Roll2Rail, where members collaborate in the basic definition and selection of the wireless technologies (incl. physical medium, architecture, protocols, RAMS & (cyber)security analysis and testing in lab...) for the train to train, intra-consist and train to ground (T2G) communications and for several applications (TCMS, safety functions, CCTV,

infotainment). This collaboration will reach TRL3/4 and complete testing and validation in the laboratory.

In Shift2Rail inputs coming from Roll2Rail, TD2.1 and TD2.8 will be reviewed and considered.

Members are expected to then develop technical solutions (HW & SW) oriented to the metro segment which may include wireless routers, transmitters and receivers, adaptation of software communication layers. At least ETB and T2G and related applications will be considered. Unitary test on real vehicles before integration in the metro ITD is foreseen (TRL6/7). Some activities related to prototype manufacturing or to rent very specific equipment (e.g. channel emulators) will be subcontracted.

Then technical solutions (HW & SW) oriented to the regional segment will be developed by members. At least T2T and T2G related applications will be considered. Unitary test on real vehicles before integration in the regional ITD is foreseen. Technical solutions (HW & SW) which may include wireless routers, transmitters and receivers, adaptation of software communication layers will be developed.

Members are expected to participate together in interoperability tests to be carried out in the laboratory.

Activities allocated to Open Calls: It is expected that Roll2Rail will cover the needed research on radio communications, including definition of routers & antennas (to be later developed by communication specialised companies), cyber-security software and conformance tests. Therefore no further open calls are envisaged for this task.

### **T1.2.2 – Drive-by-data**

The objective of this task is to provide a train-wide communication network for full TCMS support including the replacement of train lines, connecting safety functions up to SIL4 and support of 'fail-safe' and 'fault-tolerant' principle, to provide an optimal train network for TCMS and OMTS services and a communication mean also for non-TCMS functions like signalling subsystems (inputs from IP2 will be required again).

Industrial members will work together to define the use case, functional, technical and performance requirements and the related architecture and interface. This definition is expected to be supported by members. They are expected to carry out RAMS analysis including safety case studies and define the SIL4 procedure. Finally they are expected to evaluate and select the most suitable technologies (up to TRL 3/4).

Technical solutions (HW & SW) based on the previous definitions oriented to the metro segments will be developed. Existing HW (switches, CCUs, RIOMs, HMIs) & SW will be adapted accordingly and unitary tests will be carried out in the laboratory before integrating the TCMS with drive-by-data (up to SIL4) capabilities deployment in the metro ITD (TRL 6/7). Studies about how these are affected cabling and relay circuitries will be carried out and new solutions will be developed here. Some small activities related to safety critical software development and certification may be subcontracted.

Technical solutions (network components) and adaptation of existing HW (switches, CCUs) & SW to regional segment applications will be performed by one industrial member. In addition TCMS with



drive-by-data (up to SIL4) capabilities, oriented to regional services, will be deployed (TRL5/6) for assessment and demonstration in lab.

Members are expected to develop technical solutions for the possibility to demonstrate a drive-by-data functionality up to TRL (4/5) and also take into account the internal interface between IP1 and IP2.

The following interactions with IP2 will be considered:

1. The interface to the ATP/ETCS:

- Inputs: For each specific input: SIL requirements, resolution and range, update rate/response-time from change.
- Outputs: For each specific output: SIL-required, data format, response-time
- DMI access requirements

2. Data interfaces of ATO:

- Inputs: For each specific input: SIL requirements, resolution and range, update rate/response-time from change
- Outputs: For each specific output: SIL-required, data format, response-time
- DMI access requirements

3. Data interfaces of other equipment, e.g. data loggers

4. Train integrity function requirements

5. Virtually Coupled Train Set requirements

Once the technical solutions are developed, interoperability will be checked in the laboratory with the participation of members.

To be covered through Open Calls: In addition it is foreseen the need for some basic collaborative research on safe critical systems for control and monitoring systems through communication buses, mainly coming from other sectors like aeronautics, industrial (nuclear & chemical plants). In that sense, the aeronautical AFDX – Avionics Full Duplex Switched Ethernet (ARINC 664 standard) should be considered as state-of-the-art and its feasibility for railways analysed. Research on how such existing protocols and architectures could be adapted and implemented should be carried out.

Subcontracting: The participation of switches/routers manufacturers to develop “drive-by-data” enabled equipment and certified laboratories for testing is foreseen as subcontractors.

### **T1.2.3 – Functional Distribution Architecture**

The task targets a new architectural concept based on a standardised framework and distributed computing to allow the execution of whichever functions on high performing end devices distributed along the vehicle, with different safety and integrity levels. Functions will be plugged in the framework and run isolated from each other with the aim at avoiding complete TCMS re-commissioning after any application change. Based on the technology used, it will be guaranteed that



safety (e.g. brakes) and non-safety (e.g. CCTV) relevant functions are feedback free and separated from each other.

The concept behind the functional distribution architecture is equivalent to AUTOSAR/MICROSAR in the car industry or ARINC 654 standard in aviation.

Members will participate in the specification (use case definition, functional, technical, performance and RAMS requirements) and in the definition of the architecture, its layers and interfaces. Definition of application profiles of interoperability related functions (for standardisation) will be done also together. An analysis of the possible impact of the new architecture on ATP/ETCS applications in terms of new hazards and modifications is expected to be performed. This collaboration will reach TRL2/3.

The middleware needed to support the functional distribution architecture will be developed or adapted (if exists) by the members. Existing applications will be adapted to the new architecture and existing functions (incl. HMI, alarm loggers, MCG, DOEM...) will be integrated in distributed CPUs. A modified TCMS architecture will be designed, implemented and tested in the laboratory before its deployment on the metro ITD (TRL6/7). It may be needed to subcontract some minor activities related to software development.

Members will define the application profile for traction, static inverter, door and HVAC. The implementation of SW related to these functions on the framework will be done. It will also develop and validate on test bench with control electronics implementing the functional distribution architecture with real railway main functions using the defined application profiles.

Another member will develop the middleware needed to support the functional distribution architecture and integrate existing functions in distributed CPUs. It will design and implement the simplified TCMS architecture by using the Functional Distribution Framework. Then unitary test in laboratory is expected: The new architecture, oriented to the regional rail use case, will be deployed (TRL5/6) for assessment and demonstration.

Also develop technical solutions to support the functional distribution architecture (e.g. CCTV) as well as for the demonstration of the T2G functionality (e.g. CCTV or PIS in a regional ITD).

Based on the above described development activities tests of interoperability the industrial members will be carry out in the laboratory, being the tests monitored by the members

Derived from the functional distribution architecture and the application profiles the functional open coupling (FOC) concept can be developed in a second phase. This concepts abstracts coupled train functions allowing to couple consists of different series, implementing different functions or software versions. In that sense, Members are expected to carry out the requirement analysis and define the system architecture of the FOC. This activity will reach TRL1/2. With the support of Open Calls and the train manufacturers, the FOC will be then further developed up to TRL6/7 in the regional segment.

In addition, in this task members will explore the feasibility of defining standardised hardware (including its physical interface) where the functional distribution architecture framework would run.



To be covered through Open Calls: They should include research on distributed computing and, in particular, on the feasibility of applying MICROSAR (safety AUTOSAR) or ARINC 653 architectures and middleware to railways. Thus, the calls should target experts from the car and aviation industry, mainly the suppliers of such frameworks. In a second round of Open Calls the focus should be on the Functional Open Coupling to support its design and development on top of the functional distribution architecture and the application profiles.

#### **T1.2.4 – Virtual Placing on the Market**

The goal is to develop a simulation framework in which all subsystems of the train can be simulated, allowing remote and distributed testing including hardware in-the-loop through heterogeneous communication networks. The simulation platform is completed by a toolbox to support the design, deployment, monitoring and testing of the next generation TCMS.

As a preliminary activity the conformance testing of the new technologies will be developed. These include, amongst other, the new ECN/ETB and their wireless versions, the framework supporting the functional distribution architecture and its pluggable functions or the FOC.

Members will define together the virtual certification principles (incl. train coupling) and its process with NoBos. They will collaborate in specifying functional, performance, RAM and safety requirements and in defining the simulation platform architecture and interfaces.

Members will implement and test the simulation framework, and then carry out together interoperability test of their developed simulators. The virtual communication simulator will be completed with a train electromechanical simulator (e.g. electric inputs and outputs, electric circuits, relays and train lines, train dynamics...) in order to obtain a fully virtualised train. In addition, members will develop the toolbox, the software tool set needed to configure, programme, monitor, analyse and diagnose, locally or remotely this new generation of TCMS.

Another member will analyse the possibilities to adapt/convert existing simulation tools to be part of this simulation framework:

1. Survey of existing tools/simulators
2. Analysis of architectures – e.g. port tools to common test-bench, provide remote-access to tools over internet

Members will develop specific simulations and simulators, and then carry out together interoperability tests.

Finally validation methods needed to support the virtual certification with the acceptance of notified bodies are expected to be developed

To be covered through Open Calls: Additional research contribution will be required on internet & LAN technologies (including tunneling, security, remote execution...), on simulation techniques for ECN, and on certification processes. It is also necessary that part of the work will to come from subsystem suppliers (brakes, doors, HVAC...) to support the specification, design, implementation and testing of the simulation framework, from software companies supporting the GUI/Front-End and from notified bodies.

Additional support: It is requested the participation of the European Railway Agency in this activity as advisory body, in order to guarantee that the outcomes are applicable and could be regulated.

### **T1.2.5 – Integration, Demonstration and Assessment**

#### **Integration**

Two ITD are foreseen for the TCMS: One regional ITD involving different members in order to check interoperability, and one metro ITD to test innovations under the most severe conditions (e.g. multiple radio signals, tight tunnels).

The new TCMS will be deployed for full scale demonstration on a metro vehicle, incl. wireless features (Intra-consist, T2G, and T2T), SIL4 capability, and new functional architecture. This means engineering, manufacturing and the replacement of the existing TCMS by the new one and setting back the train to its original configuration after the testing time (incl. commissioning.). Integration of innovations from other TD (e.g. bogie monitoring & traction) in the TCMS of metro vehicle will be done here. Part of the budget will be dedicated to purchase materials and equipment needed to integrate the innovations.

Two wireless communication networks will be deployed on two regional consists by different members in order to allow for additional interoperability tests when coupled together:

Also technical solutions to demonstrate the T2G on a regional ITD will be developed

Members will provide a regional consist each for the integration of the new TCMS components. The other regional consist may be provided by other train operating company outside the JU membership if necessary

#### **Demo and assessment**

This task is aimed at obtaining performance data from ITDs and to its subsequent analysis, leading to conclusions on the actual benefits and improvements achieved. It will be assessed if the results fulfil the requirements specified in T1.2.0, so when possible each requirement will be tested.

Members will prepare together a common test procedure and reporting templates for easier assessment of results.

Members will set up the TCMS for the metro ITD, and to deploy tools and equipment to carry out test. Needed devices (e.g. radio analysers) will be rented. Tests will be performed, results will be assessed and reports prepared. Operational costs of the metro vehicle during the tests and demo and the two authorisation processes (after the integration and once back to the original state after the demo) will be covered by the member. In that sense, no additional support will be necessary in this metro ITD.

Members will be in charge of the review of the performance data and conclusions.

Members working in the Regional ITD are expected to carry out the assessment of demonstrators including the test programmes and reports for the own solutions. At least one member will support the regional ITD by facilitating the tests of their modified consist (e.g. drivers, maintenance...). They are also expected to take part in the assessment of the results.

Figure 13: Regional ITD

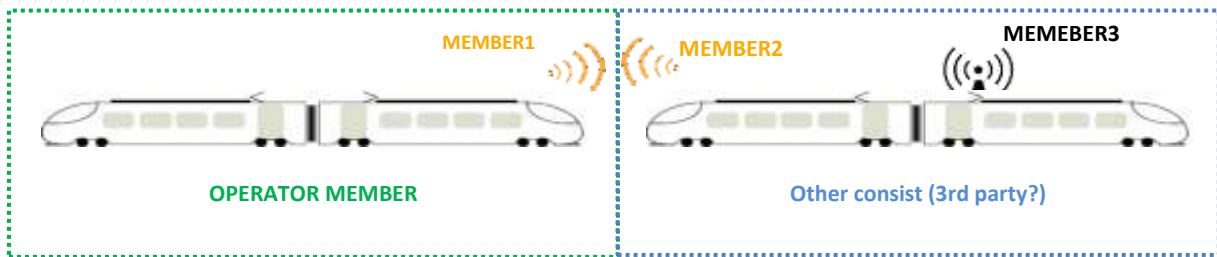

Figure 14: Metro ITD



### 1.5.2.6. Planning and budget:

TASKS	TRL	2015	2016	2017	2018	2019	2020	2021
<b>TD1.2</b>	<b>TCMS</b>							
1.2.0 General specification	-							
1.2.1 Wireless TCMS	6/7							
1.2.2 Drive-by-data	6/7							
1.2.3 Functional distribution architect.	6/7							
1.2.4 Virtual placing on the market	5							
1.2.5 Integration, demo & assessment	6/7							
1.2.6 Technical coordination	-							

Where:

- In red: Roll2Rail
- Orange dotted line: First milestone. Specification and detailed architectures finalised. TRL2/3.
- Green dotted line: Second milestone. Technologies implemented and validated in laboratory or small real scenarios. TRL 4/5.

The estimated total budget for TCMS TD is around 48.8 M€.

### 1.5.3. TD1.3 Carbody Shell Demonstrator

#### 1.5.3.1. Concept and objectives of the Carbody Shell Demonstrator

The function of a carbody is to be the transport passenger container and also the physical link of all the elements of the vehicle.

Historically, passenger coaches were formed by a frame normally made of steel, which received the loads coming from the track and the other coaches, and by a cover, which had incorporated the doors, windows and gangways.

Progressive improvements were made and self-supporting steel and aluminium carbodies were created in order to reduce mass and improve crashworthiness. Regarding this issue, further developments were made in order to increase safety, as the incorporation of the anti-climbers and also the division into deformable and non-deformable areas. In addition standardisation of solutions and subassemblies has been introduced to become more cost effective.

Recent years have seen the progressive incorporation of non-metallic parts in the carbodies, such as in front cabs, rear ends, fairings, floors (floating or fixed) and under-frame coverings. All those parts are made of composite materials, which may include metallic parts but in lower proportion than in the past.

All the new composite parts are linked to the primary structure, but they do not receive loads directly from the running gear or the neighbour vehicles (exception e.g. intermediate floors in double deck vehicles).

The stresses to which carbodies are subjected are of various types:

- The stresses due to longitudinal, vertical and extraordinary forces caused by the normal movement of trains.
- Also, there are the stresses of vibration of the carbody itself, which occur by the effect of its mass and dynamic loads from the track and its effect on fatigue.
- Finally, stresses due to accidental collisions related with passive safety.

Furthermore, in case of high speed trains, there are also overpressure in the crossings with other trains particularly in tunnels, and stresses caused by lateral winds.

In the Aeronautical industry there has been an increase in the use of non-metallic materials for structural components. There has also been a corresponding increase in the knowledge of composite material behaviour and the fulfilment of all issues in relation to composite materials regarding safety.

Therefore, it seems logical that such developments could be made in the rail industry, and this project specifically focusses on the primary structure of the carbody.

The main innovation of this technology demonstrator is the use of composite materials in a hybrid carbody, where the technical and commercial issues will be investigated. The current performance of the metallic primary structures in terms of safety, durability and maintainability will also be achieved with the technologies developed and evaluated with this demonstrator.

The carbody will be designed with highly integrated structural components. However, the components have to be joined to each other. The main focus of the project is given to fiber reinforced plastics (i.e. polymeric / plastic matrix which is reinforced with fibres). Adhesive bonding in combination with riveting or other techniques will be able to join FRP as well as different materials to each other. The qualification requirements for these joints have to be developed with respect to existing standards, such as EN 12663 and EN 15227. These standards describe the load cases, the procedure of verification and the crash requirements but do not include any detailed description of the procedure which is required for joining of primary FRP and hybrid structures. Therefore, the



development and verification of a method to approve appropriate joining technologies will be crucial for introducing new carbody structures into the market.

The major challenges that have been identified are:

- Cost.
- Manufacturability.
- Maintainability.
- Reparability.
- Composite-metal and composite-composite joining technologies.
- Integration
- Fire protection
- Mechanical behaviour (strength, structural dynamics)
- Acoustic behaviour
- Assessment and authorisation

For the project success, the knowledge transfer regarding the composite materials from the aeronautic, automotive, wind energy industry or research institutes is important. However, it is important to note that the types of load and their intensity applied to the structure, the operating environment, and the safety cases are very different in the different industries. For example what is an intolerable risk in an aircraft could be tolerable in rail vehicle carbody and vice versa.

The main objective of this technology demonstrator is to achieve between 15% and 30% weight reduction for the primary structures, while maintaining the cost (or reaching a competitive cost level) and meeting the performance of current metallic carbodies by incorporating composite materials into a hybrid structure.

The integration of functions of other train subsystems will help to achieve these objectives and contribute to the overall reduction of energy consumption of the rolling stock.

**Technological output to be delivered by this TD:**

New generation carbodies made by hybrid materials (mainly composite) in the primary structure.

**Specific achievements to be delivered by this TD:**

- Between 15 and 30% weight reduction.
- Energy savings in operation, resulting from the weight reduction.
- Improvement of maintainability, coming from new concepts.
- Introduction of a specific health monitoring

The following table summarizes the objectives and related deliverables of this TD according to the S2R Master Plan:

**Table 5: Objectives and Practical contribution of the TD**

S <sup>2</sup> R Objectives	TD Objectives	Practical contribution (how)
Improved services and customer quality	Enhanced capacity	Increase of the space available for passengers on the train, due to function integration (e.g. insulation)
Reduced system costs	Reduction of manufacturing and operating costs	Possibility of integrating function in the parts made of new materials. Additional flexibility by joining sub-structures made of different materials. Energy consumption reduction due to reduced weight Infrastructure maintenance cost reduction due to reduced impact from Rolling Stock (because of reduced weight)
Simplified business processes	Propose standardisation and certification approaches	Development of common specifications for future composite material based architectures. Demonstration that recommendation for standards currently being investigated in FP7 (REFRESCO Project) are applicable.

### **1.5.3.2. Technical ambition of the Carbody Shell Demonstrator**

Over time different materials have been used for the primary structures of rail vehicles. Original vehicles were manufactured with a structural underframe and superficial body, but advances in materials and design led to completely welded steel carbodies which considerably improved safety.

Aluminium carbodies, were later developed, firstly single-walled and then double-walled extrusions, in order to improve stiffness and also avoid extra reinforcements.

Progress has also been made in steel carbodies, with continuous reductions in steel sheet thicknesses and smarter designs.

Therefore non-supporting, partially supporting and self-supporting superstructures have been developed.

Composite parts have started to be used in secondary structures such as driver cabs, rear ends, fairings, floors and underframe structures, however there is little use in primary structures.

The current state-of-the-art includes the latter and the inclusion of different assembly methods apart from welding, as riveting and bolting, to reduce costs and manufacturing time.

Although steel and aluminium cope well with the loads applied and also with the carbody functions, weight reductions can be made by using other materials apart from metals. This has been proved in the aeronautic industry, where composites are increasingly being used in structural parts after having passed all tests regarding safety.

Also manufacturing processes of composite materials have evolved from completely manual manufacturing to more automatic processes. New processes allow more repeatability and thus more control on quality.

In conclusion lighter carbodies could be made with industrial processes, provided that adequate joint methods are used and there is compliance with rail safety standards.

The following table summarizes how this TD will progress the state-of-the-art and overcome today's limitations and difficulties:

State-of-the-art	New Generation Carbody Shell
Full steel carbodies, made of thin steel sheets, cast parts, extrusions or formed sheets. No proportionality between density and strength of base material.	New carbodies with reduced weight
Full aluminium carbodies, made of extrusions, sheets, and/or reinforcements. More effective in manufacturing but with similar final weights than steel. A loss of interior space due to the necessity of having high inertias in the aluminium.	New carbodies with important reductions of weight that also have the possibility of having a high percentage of the insulating material in its interior.
Primary structure of steel and aluminium carbodies as mentioned above, where metal or composite secondary structures are joined. The design of those joints supposes important reinforcements in some cases.	As composite materials are created in the manufacturing process, possibility of more integrated and less reinforced structures.

### **State of the art in metallic carbody manufacturing**

The carbody of a rail vehicle is composed of a bearing structure, the doors, the windows, the interior with the seats, the coating, the comfort equipment (lights, air circulation, etc.)

Most of the structural components of the vehicle are based on metallic materials. Over time, aluminium has reached a balanced use compared with steel and is in use in metros, regional and high speed trains in more or less the same ratio than steel.

**Figure 15: Typical aluminium extruded carbody**

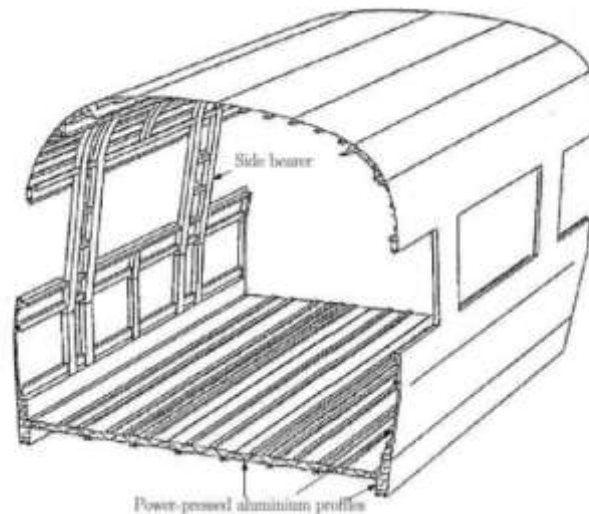

The carbody structures are currently highly optimised regarding weight per axle. The vehicles are mainly made of welded aluminium profiles, but also include metallic sheets and panels welded to each other.

As an example, the carbody roof is composed of four panels welded together, with additional horizontal stiffeners welded to them creating a transversal stiffening frame. This results in the manufacturing process of the roof requiring a lot of resources, positioning tools, welding, storing space and manipulating of the different components and subcomponents.

The process is the same for the walls and the under frame. The assembling of the under frame, the side walls and the roof takes place in a positioning and welding station.

### **State of the art in carbody welding technology / railway vehicle structures**

We have seen earlier that the train carbody (underframe, side walls and roof) are made of metallic panel welded one to the other. The welding process forms an important part of the railway industry production lines. Based on this, a number of between 20% and 30% of the staff consists of specialized and certified welders.

Welding is a mandatory process to be used in the railway sector, as much in the process of components for the traction system, as in structural parts for the process of the vehicle carbodies. The present trend is to avoid, as much as possible, manual welding in order to reduce production costs, increase consistency, productivity and quality in general.

Some welding technology, like laser, electron beams or FSW (Friction Stir Welding) can only be performed on automatic bases, but others as MIG/MAG, TIG or plasma, admit automatic and semiautomatic methods. The following table shows the main differences between manual and automatic welding:



**Table 6: Main differences between manual and automatic welding**

MANUAL OR SEMIAUTOMATIC WELDING	AUTOMATIC WELDING
<ul style="list-style-type: none"> <li>• <b>Qualified operators</b></li> <li>• <b>High formation costs</b></li> <li>• <b>Low consistency</b></li> <li>• <b>High flexibility</b></li> <li>• <b>“In process” quality control: visual inspection, acoustic, etc. High response speed</b></li> </ul>	<ul style="list-style-type: none"> <li>• Qualified operators only in the programming and tryout stages</li> <li>• Low manufacturing costs</li> <li>• High consistency and productivity</li> <li>• High adaptability: reprogramming and tryout required</li> <li>• Need for supervision systems</li> </ul>

The following two technologies are used in the welding processes for train carriages:

- **Automatic welding** for the longest straight welding joints in the longitudinal seams of the vehicle.
- **Manual welding** for the short interior welding joints where automation is difficult to realize.

In addition to welding technology, there are other joining techniques which are not as widely used as welding:

- **Mechanical fittings:** Screws, rivets, clinching and hemming operations, etc. Rivets and screws have been used in the manufacturing of the first vehicles where welded joints are being replaced. This solution is not widely used today because of the weight increase from such fittings and the improvement in quality and reliability of existing welding techniques.
- **Adhesive joining:** Although structural adhesives present improved resistant properties, their use in railway vehicle manufacturing is still not considered for joining of metallic materials. This is because currently joints designed according to the implemented state of rail technology cannot compete with welded joints as they are industrially designed and manufactured in terms of mechanical resistance (traction, torsion, fatigue, etc.) and long-term behaviour (deterioration).

#### **State of the art in carriage structures made of composite materials**

The weight per seat for passenger trains goes from 400kg per seat to 800kg. However some high speed trains, such as the German ICE 2, can reach up to 1100kg per seat. The benchmark in lightweight material is established for the Japanese high speed train, “Shinkansen”, (537kg per seat although there are differences in the load specification), and the commuter train “Suburban” of Copenhagen (360 kg per seat).

There are different potential weight reduction strategies for the railway vehicles:

- Lightening based on alternative concepts and solutions to find the optimum solution of the whole vehicle (components and systems). Examples would be the mechatronic based suspension technology and articulated trains.
- Lightening based on material changes on components and subcomponents of the train without modifying the overall main design of the train.

- Lightening based on optimised requirements based on current interpretation of existing standards.

In the case of material changes, the use of composite material would offer a great lightening potential because of the relation between strength and density. The present study focuses on that field.

In rolling stock a limitation in the axle of load exists. Taking into account that the introduction of more passengers and even new equipment (auxiliary energy storage) supposed an added weight to the structure of the train, the structure should be lightened. The structure of carbody, i.e. walls, roof, underframe, and structural beams, suppose around 25% of total weight of a vehicle.

Indirectly, a reduction weight of carbody results in:

- Reduced energy consumption and consequently reduction of greenhouse gas emission.
- In combination with other measures reduction of external noise and ground vibrations
- Reduction of the deterioration of the rolling stock

Within this general context, the weight reduction is approached as an introduction of composite structure carbody, but nevertheless composite has other notable advantages such as:

- **Versatile design.** More freedom to implement complex designs in comparison with the conventional materials
  - **Integration of components / single part function**, structure or module. Solution based on composite material allows complex manufacturing structures and therefore high potential for integration of functions and elements. All this translates into obvious advantages, since it usually represents a saving in manufacturing processes of different components, joints and assembly thereof, manufacturing tooling, and logistics.
  - **Reduction of complex manufacture / assembly**, reducing the potential number of pieces / integration capabilities that technology offers
  - **Simplification of final assembly.** Decreasing use of fasteners and welding results in short assembly times
- **Improvement of fatigue behavior** in some areas, in particular in high loaded areas where welding e.g. creates residual stresses.

### Composite material application in trains

In the terrestrial transport area, composite material including sandwich structures can be found in buses and trains, for instance used for lateral walls or interior panel. This type of material is currently and regularly used in three specific cases:

- The front ends of trains and locomotives, are often manufactured from composite material since the 80's because this material has simplified the manufacturing of this assemblies. They often contain free form surfaces which are difficult or expensive to be manufactured from

conventional material. The part made of composite material of the front walls doesn't have a structural function; metallic elements are introduced for that purpose. Examples of that technology would be the locomotives XPT in Australia, the locomotive ETR500 in Italia, the French TGV or the Swiss locomotive 2000<sup>3</sup>.

**Figure 16: The Cab Front made with sandwich material and manufactured by infusion**



- Examples of lateral panels made of glass fibre epoxy resin laminates can be found in such trains as the Swedish train Regina, the Italian Munico or the Swiss train Neitec of Schindler<sup>4</sup>.

**Figure 17: Top panel of Regina Train from Sweden**



- Interior components, such as cladding panels and seats.

<sup>3</sup> Multiscale approach for the design of composite sandwich structures for train application - A. Zinno \*, E. Fusco, A. Prota, G. Manfredi

<sup>4</sup> Light-Weighting Methodology in Rail Vehicle Design through Introduction of Load Carrying Sandwich Panels - Licentiate Thesis -David Wennberg - Centre for Eco2 Vehicle Design -Department of Aeronautical and Vehicle Engineering

**Figure 18: Seat manufacturing by RTM by Ashland Composite**



Other than the previous applications, the use of composite materials including sandwich structures has been limited. However, in the last years prototypes have been developed for structural applications like bearing structures, lateral walls and even complete cabins.

In most cases, the technical feasibility of producing the prototypes has been proven but the introduction in the market has been limited by factors such as the associated cost of the solution, the necessary investment and the lack of an existing validation process with specific criteria.

**The existing lack of confidence towards composite materials for structural application comes from a void in legislation that currently does not set up the requirements, conformity assessment procedures and criteria for acceptance. This is precisely one of the reasons that justify the need for investigation on the use of composite materials and composite material design and construction for structural applications in the railway sector.**

#### **Composite materials in aircraft structure**

The most relevant sector in application of composite materials is aircraft industry. It seems appropriate to review some examples of composite materials introduced in aircraft structures.

Currently, composite and aluminium materials are mostly used in the structure. The introduction of composite materials in civil aviation started in the 1970s, though initially with little impact on the percentage of total weight of the aircraft structure.

However, the use has gradually increased with the Boeing B787 currently being approximately 50% of the structural weight.

The Airbus A350XWB has reached 52% of composite material in the structure. These values are perhaps more indicative when there are expressed in terms of volume (Approximately, 80% of composite structure by volume in B-787)

**Figure 19: Developments in the use of composite materials in civil aviation<sup>5</sup>**

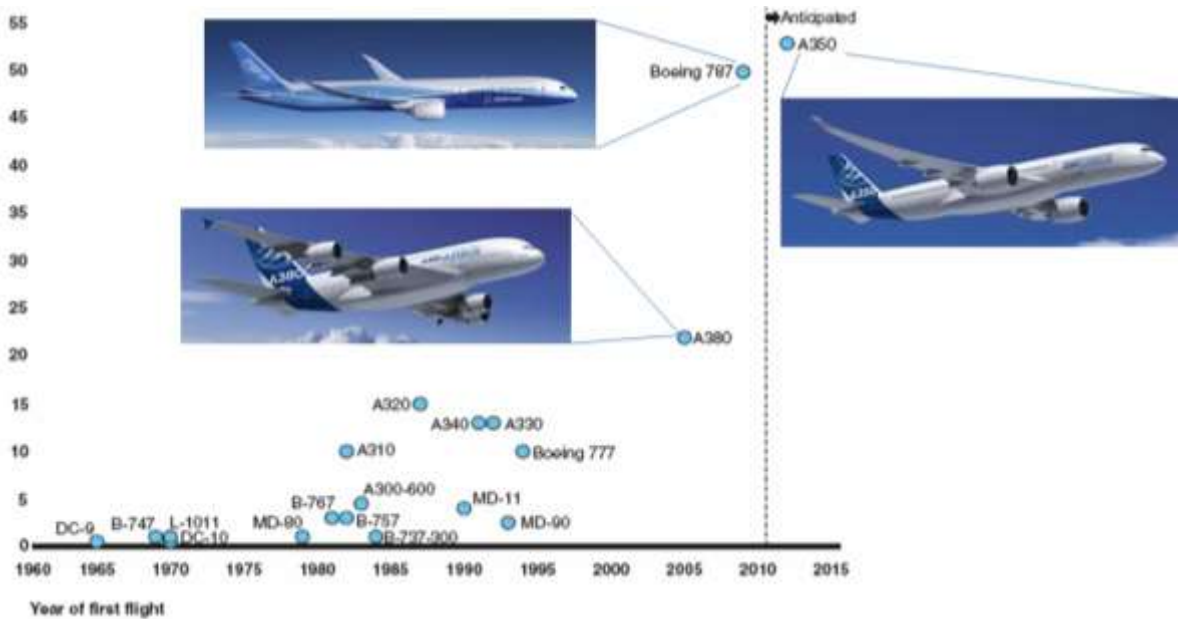

This increase in the use of these materials has been motivated mainly by offering excellent properties such as high strength and specific stiffness, corrosion resistance and high energy absorption capacity and impact resistance.

Furthermore, considerable efforts in R&D investments carried out by aviation industry in composite materials.

Material selection has a direct influence in costs operation: high influence of aircraft cost (material and process cost), high influence of fuel consumption (more lightweight) and maintenance cost (inspection and repairs).

**Figure 20: Breakdown of direct operating costs for a typical commercial aircraft (Source: Airbus)**

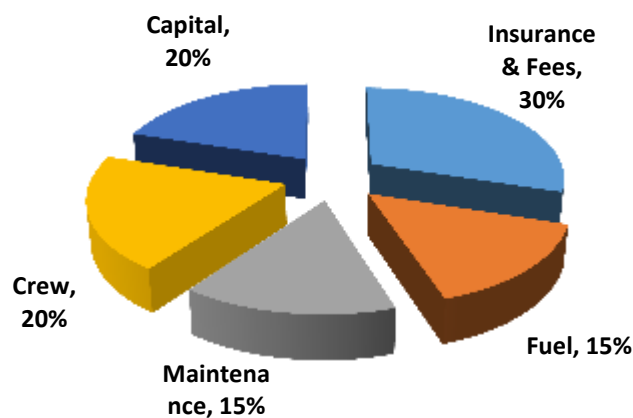

<sup>5</sup> "Worries about new composite made airplane", <http://www.1001crash.com/index-page-composite-lg-2.html>

The use of composite in place of metallic materials in structures approaches requires different consideration for design and service, damage tolerance and new repairs philosophy.

However, in material selection stages and definition of a new aircraft design, it is also need to consider the security aspects, despite other various factors such as cost.

Therefore, to implement any new material system in this sector, is a hard work due to extensive qualification requirements. These security requirements also have been required to adopt an approach of progressive introduction of composites in structural applications and get confidence and experience in technologies manufacturing and behaviour of these materials in operation for the long-term.

**Figure 21: Distribution of material weight in the Airbus A350 XWB**

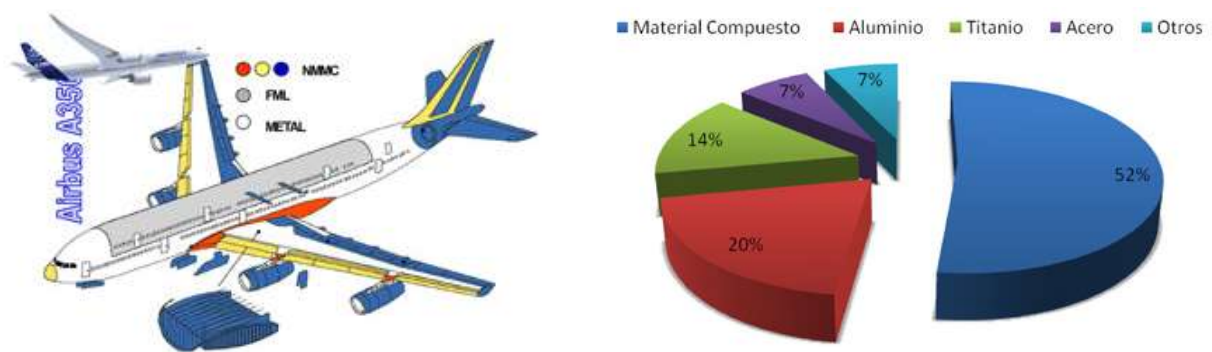

Due to an increased confidence in the use of composite materials, developments have been addressing parts of greater responsibility. This percentage has increased significantly in the A350XWB, where 52% of the structure, including the fuselage and wing, being made in composite material. The use of these materials may be more widespread if possible, in certain programmes of other sectors of civil aviation, as are the Executive and General Aviation, especially VLJ (high projection USA).

It has been demonstrated that with composite structural applications it is possible to reach weight reductions around 15-20% if these are compared with aluminium structures. However, in some cases, the use of composites has meant a cost increased in manufacture process, so it is necessary to optimize the composite technology.

#### **State of the art about preliminary projects on composite materials**

Experience from other industry sectors has shown that the validation criteria that are being used to assess different materials have been made possible by the parallel development of common frameworks and projects.

An aviation safety agency (EASA and FAA) has been issuing product certificates since September 2008 on the basis of Commission Regulation (EC) No. 1702/2003. These agencies are also promoting research programmes and collaborations with manufacturers and Standards Organisations with the

main purpose of addressing industry demand through the generation and continuous revision of certification methodologies.

In 2005, Talgo submitted in Helsinki the prototype double-decker train TALGO 22. The structure of this prototype was made with composite materials.

**Figure 22: TALGO 22 Structure prototype**



**Figure 23: Cab structure with lightweight materials for Newcastle Train**



Recent research through the DE-LIGHT project (EU FP6) has proven the feasibility of using lightweight materials in a structural capacity for rail vehicles. <http://www.delight-trans.net/>

The composite driver's cab developed through that project demonstrated that a lightweight cab can be developed which meet the structural and crashworthy requirements of the EN standards, whilst having the potential to realize weight savings and cost savings. Technology Demonstration of



Carbody shell will build upon this knowledge by extending the scope from individual components (such as the cab) to the entire carbody.

By taking advantage of developments in other sectors and using information from REFRESCO project, TD1.3 Carbody will propose procedures for the assessment of vehicles with structural composite materials in order to accelerate the introduction of new lightweight materials in new vehicles in railway sector.

### **1.5.3.3. Specific Demonstration activities and contribution to ITDs/SPDs**

The following table summarises the contribution of TD1.3 Carbodyshell to the overall S2R programme.

**Table 7: Contribution of TD1.3 Carbodyshell to the overall S2R programme**

Research Area	Specific Techn. objective	Specification Activities?	Demonstrator		Focus of activity
			Market	TRL	
Carbody shell	Composite / hybrid carbodyshell	Technical specification of materials and manufact.	Metro	4	Demonstrate composite/ hybrid lightweight bodyshell concept, material & joining technologies and manufacturing process
			High Speed	4/7	Demonstrate composite/hybrid lightweight bodyshell concept, material & joining technologies and manufacturing process

### **1.5.3.4. Impact of the Carbodyshell Demonstrator**

The most significant quantitative benefits to be obtained in relation to the objectives listed in the previous sections are:

- Weight reduction for the carbody:
  - with effects on energy consumption of the whole train
  - to enable higher degree of equipment to improve comfort and function
  - to allow alternative vehicle concepts
- Improvements in manufacturing technologies, pushed by the need to compensate partly higher costs for material or staff
- Reduction of the time to market
- More attractive products
- Development of new skills in the Railway Industry
- Side effects for suppliers and research institutes



Those specific benefits will have a major impact in the Shift2Rail system-level KPIs highlighted in the Master Plan:

1. Reduction of energy consumption (equivalent to the weight reduction of the whole vehicle) by the different light weight strategies.
2. Reduction of life-cycle costs: Simplification of maintenance with more modular structures and function integration and reduction in energy consumption due to overall weight reduction. Reduction of production costs by selecting the most suitable manufacturing technology and material depending on the individual product design (loads, quantities, application)
3. Increase of capacity (potentially up to 10%): increase of the number of passengers/ meter of train length, derived from better use of space while meeting the axle load regulation/TSIs.

All the principal elements required for rapid market uptake after the work within Shift2Rail have been taken into account in this proposal. These are:

1. Demonstration of technologies to high TRL to give credibility and clearly show benefits.
2. Basic common design principles based on common materials and manufacturing processes.
3. Orderly development strongly supported in brand-new and existing standards which will increase the confidence of future clients and will lead to better acceptance of the rupture technology, thus facilitating the rapid deployment in the technology.

The existence of technical standards and manufacturing processes available will facilitate the development of modular solutions and families of components by providers of components and subassemblies, which will help reduce and stabilize costs in a relatively short period of time.

Results coming from the on-going FP7 REFRESCO project<sup>6</sup>, where gaps in the existing normative framework will be identified and approaches for new standards will be presented, and will be used throughout the project and will have further studies. This TD will serve to put into practice the applicability of those new or modified standards, thus contributing to evolution of the TSI's and national rules that will allow the use of those new materials in structural parts of carbody.

The findings of the TD Carbodyshell can have impact on the TD1.6 (Doors, Sheets) and TD1.7 (Interiors) and the results may serve as inputs to the CCA "Energy".

Usual interfaces to the carbody are represented in Figure 24.

---

<sup>6</sup> <http://www.refresco-project.eu/>

Figure 24: Usual interfaces to the carbody shell

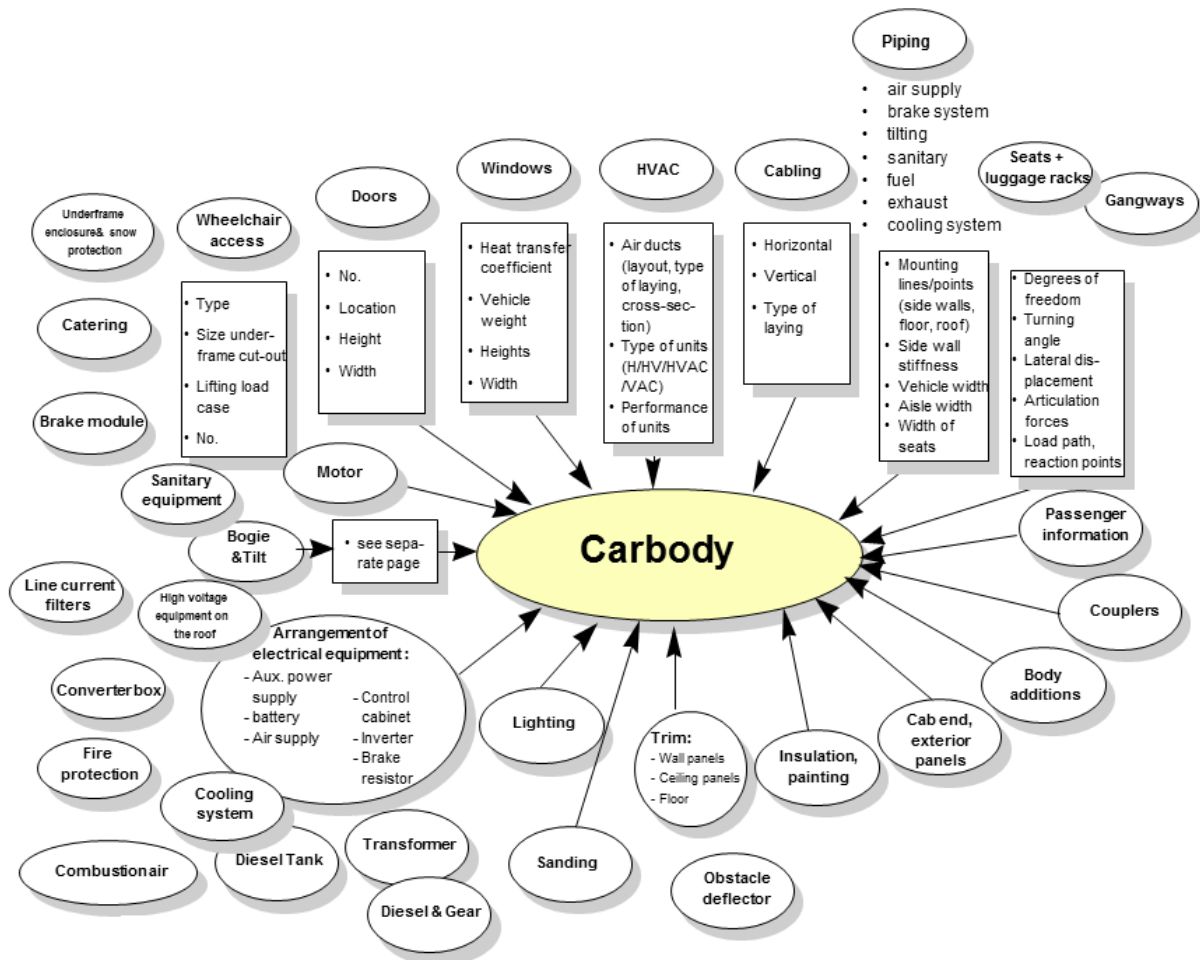

1.5.3.5. Implementation of the work programme

A clear methodology has been devised for the organisation of the technical work in the project, in order to maximize the probability that the desired final objectives are met. This is represented in Figure 25.

Figure 25: Outline of Technical Task





The first task to be carried out will be the creation of the carbody general specifications based in the applicable standards, and also on the results of the Roll2Rail call off in which this topic will already be prepared.

In a second phase a deep study of the carbodies will be done, considering aspects as material alternatives, manufacturing alternatives and material characterisation.

Once the necessities of carbodies for Metro and High Speed segments have been understood, it will start the design phase where conceptual design, structural and non-structural assessment and mass analysis will be performed.

A parallel-in-time behaviour research task will deal with subjects like risk analysis, economic feasibility, reparability, maintainability and sustainability.

After this the manufacturing task will start, which include manufacturing of the demonstrators itself, as well as additional development tasks.

The carbodies will need to be validated against structural strength, fire safety, fatigue, electric and electromagnetic compatibility and passive safety.

Finally, documents about the assessment of composite carbodies will be presented and discussed with potential standardisation and regulatory bodies.

In parallel, activities regarding noise and vibration harshness and also energy management will be done. Although belonging to cross-cutting activities, those sub-tasks have been included into the project schedule.

A group of members will participate in the following tasks of the TD1.3 – Carbodyshell to meet the desired objectives. They will focus in the development of hybrid composite/metallic structures probably for the metro segment.

The group is expected to support the high speed investigations to ensure that synergies between both sectors can be considered.

The group should collaborate with other members, with clearly identified knowledge and experiences on all issues related to the use of light weight/composite material for structural parts of vehicles. These members should have:

- Full competency in all rail specific requirements of operation regarding track, vehicle and passenger needs
- Full competency in all fields of manufacturing of rail vehicles including carbody
- Full competency for maintainability and reparability operations
- Full competency for quasi static, fatigue and on track tests
- Competent partner to support the specification and validation of a rail vehicle

The tasks are expected to be supported by members with competencies and experience from the aeronautic industry including:

- Characterizing, preliminary and detail designing, manufacturing and assembling composite components
- Composite materials physic-chemical characterisation. Mechanical testing, integral parts manufacturing processes development and automation.
- Composite material selection, development of manufacturing process, design of composite parts and structures, joining technologies, test and characterisation.

“Open Calls” are necessary in order to enrich the scientific knowledge of members and to obtain a balanced distribution of work.

The following was identified as knowledge gaps which would need to be provided by the Open calls:

1. Material, joint & manufacturing knowledge. Support process/ material selection
2. Manufacturing abilities for materials, tools and assembly
3. Support design solutions
  - Software for design, analysis and manufacturing documentation
4. Validation support
  - Test for material properties
  - Testing of joints
  - Knowledge in prognostic and safety monitoring

The open calls will also be beneficial to reach a good spread of competencies over the European Industry and a good distribution of the available budget between Metro and High speed demonstrators.

In the following the different intended subtasks are clarified:

#### **T1.3.1 – General specification**

The objective of this task is to create the main technical specifications of the project, taking into account current standards and the results available from the FP7 REFRESCO project. With respect to a joining technology for primary carbody structures, one of the main objectives of this task is the development of a concept for their assessment concept on the basis of adhesive bonding (bolting if necessary) for a metro/ high speed demonstrator.

Members will collaborate in this task, as well as partners from Open Calls with specific knowledge in new materials and joining technologies.

### **T1.3.2 – Carbody study**

The main objective of this task is the selection of the material and manufacturing process to be used based on a global study of available composite materials carbody and manufacturing process

This task is divided into three parts:

1. Material alternatives analysis. Study of the available state of the art, benchmarking study and the identification of standard gaps in composite and hybrid materials structures.
2. Manufacturing alternatives analysis (RTM, Prepreg, hand and automated layout etc). In addition to study the best alternative to develop the structure, the joint elements in this task is critical, so require an intensive study to find the best way to deal with it.
3. Selection of material to be used and characterisation of it.

Members will collaborate in this task, distributing among them the different cases for study.

Some members will focus on material behaviour incl. tests, material alternatives and acoustic behaviour.

Manufacturing and material alternatives will be analysed collaborative and equal distributed. Tests are expected to be supported by an experienced member and test institutes from Open Calls.

### **T1.3.3 – Design**

The main objective of this task is the design of the TRL 4 demonstrator by a split between all members (hybrid solutions, joints, materials, surface treatments etc.).

This design will be carry out assuring the fulfilment of the structural and non-structural requirements that are included in the current regulatory frame as well as those that had been identified in the carbody study stage.

The design will be completed with a weight analysis that will be used to establish the weight reduction a general tendency for the development of weight reduction will be derived.

Cross cutting activities e.g. for EMC are to be considered.

Included is also work to assure weight reduction is not having an adverse effect on noise and vibration transmission for carbody. This implies definition of acoustical design targets for the carbody as well as optimisation work to get an optimised setting of the acoustical behaviour on various parts of the carbody. It is necessary to assure that acoustical constraints are not leading to more weight than necessary. Activities form both members and open calls will be required for the above task on acoustic design.

Members will collaborate in this task on the different cases for study.

The basis in this task is to learn how to design with composite material.

The use of specific software and training for this software will be needed.



Therefore an experienced member and Open Calls in addition are needed to support the design activities.

Members will design structural light weight components. The needed interface information to enable others to use the components in the project will be provided.

#### **T1.3.4 – Behaviour research**

The aim of this task is to develop the following tasks:

- Failure mode and effects and criticality analysis
- Fire & smoke
- (ballast) impact
- Failure detectability
- Economic feasibility
- Reparability and Maintainability study
- Sustainability
- Weight reduction analysis
- Quality assurance

Members will collaborate in this task. Open Calls for the scientific background are required.

#### **T1.3.5 – Manufacturing**

Composite structures are manufactured using a wide variety of manufacturing process. The ideal processing route for a particular structure will depend on the chosen fibre/ matrix or sandwich type, processing volume, quality required, and the form of the component etc. In this phase, all these issues should be addressed right from the beginning of the development cycle for a structure.

Members will collaborate in this task with an orientation to the metro and high speed segments and different cases for study.

Open Calls are required for the scientific background.

The members will manufacture specific structural light weight components, designed in T1.3.3 and a high speed demonstrator with due consideration to the experience from the aeronautic applications.

#### **T1.3.6 – Validation test**

TSIs specify the requirements and tests to carry out for rolling stock validation and authorisation.

Members will collaborate in this task, distributing among them the different cases for study:

Some members will test the demonstrator in the lab, designed in T1.3.3 and manufactured in T1.3.5, up to TRL4

Members will realize a demonstrator on TRL7 for High speed application

### 1.5.3.6. Planning and budget:

TDs	TASKS	TRL	2016	2017	2018	2019	2020	2021	2022
<b>TD1.3</b>	<b>CARBODYSHELL</b>								
	1.3.1 General specification	2							
	1.3.2 Carbody study	2							
	1.3.3 Design	2							
	1.3.4 Behaviour research	3							
	1.3.5 Manufacturing	3							
	1.3.6 Validation test	4							
	1.3.7 Final report	-							

The estimated total budget for Carbodyshell TD is around 26,7 M€.

### 1.5.4. TD1.4 Running Gear Demonstrator

#### 1.5.4.1. Concept and objectives of the Running Gear Demonstrator

Bogie systems deliver a compromise of safety, reliability, comfort and performance. The scope for improvements in performance and reduction in wear using conventional systems is small without compromising safety and comfort. The next generation of bogie solution needs to deliver reduced infrastructure / wheel wear and damage, whilst providing higher reliability and availability, with lower maintenance costs. This challenge is made greater by the need for increased high speed stability, excellent curving performance, improved comfort and optimised systems for both air borne and structure borne noise. Train operators are also increasingly focusing on reducing energy usage, so innovative solutions are needed to reduce energy loss through rolling resistance as well as aerodynamic drag, and reduced vehicle and bogie mass. All these requirements have to be met without compromising safety. The solutions will also provide enablers for far reaching technology steps in the long term future and this will be considered from the specifications stage.

The work to be developed in this Technology Demonstrator includes:

- New sensing architectures and functionality to monitor both bogie and track.
- Light weight and optimised materials validated and certified for the bogie environment.
- The definition and validation of actuator technology to control bogies and wheelsets. The development of a new noise and vibration assessment methodology.

As the objective is to develop a broad technology base, dynamic field tests and demonstrators will be applied in both mainline and mass transit applications to prove service maturity.

The output from this demonstrator will improve **System Capacity** by allowing higher operating speeds in curves and through accommodating a higher payload as a result of lower mass running gear. Reduced generation of noise can result in more trains being certified to travel on a given network, further increasing capacity. Reduced forces imposed on the track through improved curving with mechatronic devices and lower mass bogies will reduce track maintenance requirements,

increasing the availability and capacity of the network. Furthermore, the improved ride and curving performance will lead to **higher reliability/availability** of the vehicles and significant savings in wheelset maintenance and longer life, and to lower **energy consumption**, thus providing a **Lifecycle cost (LCC)** benefit for the operator. Energy consumption is further reduced due to lower mass of running gear. **Attractiveness** is also improved as the Mechatronic bogie concept (MTB) provides a higher ride quality and less potential for exterior and interior noise.

The approach will begin with a thorough review of the specifications of running gear of the future. In the second phase, technologies will be individually developed covering the whole development process from basic research, lower level specifications, technology development, prototypes and laboratory tests, confirming their performance and gaining a more comprehensive understanding of these technologies. Next, specifications and architectures at a whole system level will be re-assessed and the most adequate solutions for the different types of service and operation conditions will be proposed. The final tasks are twofold:

1. A number of different running gear solutions, including those implying different vehicle architecture, bringing clear contributions to the Shift2Rail global Key Performance Indicators (KPIs) will be demonstrated using Demonstrators.
2. Technical standards based on the technologies proposed will be developed in order to promote future deployment.

A business case / cost model approach will be taken throughout the project to focus on the viable target applications.

In 2010, UIC analysed the future needs for high speed rolling stock, providing recommendations for the running gear<sup>7</sup>. Below are key extracts from this document that could be considered as input for the pre-requirement work:

1. Active suspension (full active suspension or semi active suspension) is increasingly being introduced to control secondary suspension, mainly to reduce lateral vibration but which may also help to reduce vertical vibration.
2. Materials and structure design for passenger cars should aim to dampen or cut noise emanating from the floor, windows, walls, ceiling and eliminate sources of noise generally.
3. A large number of sensors can be placed on the bogie to measure status parameters such as temperature, vibration acceleration, structural safety, and so on. Radio communication can be used instead of wiring to make placement of sensors easier and improve reliability.
4. Axle load should be minimised to reduce infrastructure maintenance work unless this conflicts with safety and operational needs like anti-collision structure, signalling, and so on. Since bogies are by definition very heavy, simplifying their structure can be an effective way to reduce overall weight. Generally, non-articulated and EMU type structures have lower maximum axle loads. Weight reduction also has a positive effect on energy consumption.
5. Rolling noise reduced through measures applied at wheel/rail interaction level. Parts and components should be designed to limit structural noise as much as possible., for example by

---

<sup>7</sup> Report, Necessities for future high speed rolling stock, UIC High Speed January 2010



rubber-metal interfaces for minimal noise and vibration transmission, wheel shapes emitting lower noise levels, as well as reduced wheel roughness by improved curving performance.

6. Ground vibration depends on track side conditions, infrastructure, axle distribution in a train set and axle load. The most effective measure to tackle this in the case of RS is to reduce axle loads.

The recommendations can be condensed to the four main innovations that are envisaged to develop within the ambit of these initiatives:

- Sensing Functionality
- Optimised Bogie Materials
- Active Suspension and Bogie Control Technology
- Noise and Vibration Reduction of Running Gear

As Part of the S2R Project, the Running gear part has three main aims:

- Develop a new generation of light weight bogie systems which result in reduced infrastructure/wheel wear and damage and energy loss, whilst providing higher reliability and availability with lower maintenance costs.
- Develop lighter running gear based on optimised materials as well as new active suspensions and bogie control technologies in order to reduce wear, noise and vibration levels.
- Make the “authorisation to put into service” process significantly cheaper, faster and easier to be applied, in order to promote interoperability over Europe, without reducing the safety level.

**Technological output to be delivered by this TD:**

A step change in running gear solutions through the development of mechatronic systems, introduction of improved materials and new sensing and health monitoring functionality, supported by mechanisms for easier authorisation.

**Specific achievements to be delivered by this TD**

- Weight reduction, which will contribute to reduce by up to 50% cost, time and effort in engineering, integration and authorisation phases.
- Reduce the unsprung mass: this will help reduce track damage, wear and vibrations, which will contribute to reduce by up to 20% system cost
- Reduce wheel & rail wear (especially RCF) through improved (controlled) performance on straight as well as curved track including wear-resistant materials, which will reduce cost by up to 20%
- Improve ride conditions through the use of active/semi-active suspension systems
- Reduction of bogie associated inspection and maintenance by monitoring which will contribute by up to 20% in maintenance cost reduction
- Reduction of costs for bogie sensor equipment by 20%
- Standards that support the introduction of advanced materials, sensors and monitoring and active control systems.
- Recommendation of validated methods required for reduction of running gear noise and vibration.
- Faster authorisation at lower cost levels

The following table shows how the proposed activity will contribute to the achievement of the S2R objectives as stated in the S2R Master Plan:

**Table 8: Objectives and deliverables of the TD**

S2R Objectives	TD Objectives	Practical contribution (how)
Improved services and customer quality	Improved passengers comfort as well as increased availability	Prototype tests as well as test specifications of subsystems.
Reduced system costs	Overall enhanced curving and riding performance of the future running gear generations. Running gear maintenance cost reduction as well as reduced wheel and track LCC.	Test reports regarding rail wheel contact (RCF) and riding performance, advanced algorithms models, SW and HW prototype, showing most effective contributions to improve Material and specification with common standards, interfaces and test procedures, Laboratory system solution, on system demonstrator
Simplified business processes	Reduction of Time and Cost of light weight material, sensitisation and active control system validation process	Standardisation of validation process
Enhanced interoperability	Enhanced standardisation of sensorisation architecture and interfaces. Standardized HW and SW communications protocols.	Introduction of common standards, interfaces and assessment procedures, lab test results.



#### **1.5.4.2. Technical ambition of the Running Gear Systems Demonstrator**

Bogie systems deliver a balance between reliability, comfort and performance, whilst ensuring safety. The scope for improvements in performance and reduction in wear and damage to the vehicle / track interface using conventional systems is small without compromising safety and comfort. The next generation of bogie solution needs to deliver reduced infrastructure / wheel wear and damage, whilst providing higher reliability and availability, with lower maintenance costs.

The work to be developed in this Technology Demonstrator includes:

- New sensing and health monitoring architectures and functionality to monitor both bogie and track.
- Light weight and LCC-optimised materials validated and certified for the bogie environment.
- The definition and validation of actuator technology to control bogies and wheelsets.
- The development of a new noise and vibration assessment methodology.
- To make a breakthrough in performance of the authorisation process.

The approach will begin with a thorough review of the specifications and requirements of running gear of the future. The results from the Running Gear related activities in the lighthouse project Roll<sub>2</sub>Rail will provide guidance for selection of technologies with strongest contribution to the S2R overall targets. In the second phase technologies will be individually developed covering the whole development process from basic research, lower level specifications, technology development, prototypes and laboratory tests, confirming their performance and gaining a more comprehensive understanding of these technologies. Next, specifications and architectures at a whole system level will be re-assessed and the most adequate solutions for the different types of service and operation conditions will be proposed. The final tasks are twofold:

1. A number of different running gear solutions bringing clear contributions to the Shift2Rail global Key Performance Indicators (KPIs) will be verified using demonstration scenarios.
2. Technical standards based on the technologies proposed will be developed in order to promote future deployment.

Additionally the authorisation process needs attention in order to get the innovations in place.

#### **Interaction with other TDs (of the same IP and/or of the other IPs):**

On the one hand, running gear systems will communicate with train level systems.

Interfaces including protocols towards TCMS have to be defined and standardised.

On the other hand, common technologies like wireless communication or energy harvesting will be analysed and developed collaboratively.

- IP1 – TD Traction/Braking/Carbody: Lighter Running gears will create opportunities in the train concepts, therefore a direct interaction with traction and braking



- IP3 – Infrastructure: Next generation passive/active suspension and curving control designs enables radical new thinking for reduced of wear (including RCF) of curved and straight track as well as of other high cost infrastructure components.
- IP5 – Freight. Technology advances in IP1 potentially suitable in freight applications.



The following table summarizes how this TD will progress the state-of-the-art and overcome today's limitations and difficulties:

State-of-the-art	New Generation Running Gear
Trailer Bogies designed for 20 tons axle load are approximately 6.5 – 7 tons in weight and contain around 90% of steel	Future Trailer Bogie concepts with around 5 to 5.5 tons of weight, with functional integration of suspensions, frames, wheelsets and brake equipment and light weight materials further reduction coming from Bogie concepts
Different requirements are implicitly/historically considering steel as preferred material (e.g fire regulations, maintenance, inspectability)	Harmonized requirements and design principles applicable for other materials than steel allowing new light weight component and or concepts to be applied in running gear.
Architecture based on steel material capabilities	New materials allowing functional integrations and new Bogie concepts /architectures including mechatronics
Traditional break-down on components functions with traditional (sometimes not very innovative) suppliers	New concepts and materials allowing new solutions on components and their integration to achieve new solutions, allowing new suppliers from other businesses entering the market.
Light weight perceived as 'costly'	Cost efficient / cost neutral light weight solutions
Uncertainty about benefits of light weight design and materials in Bogies	Clarity about the 'which, where and how light solutions' and their benefits (Technology Roadmap)
Sensors specially developed or customized for running gear application, produced in small series and with high costs	New standardised sensors fit for purpose in the running gear application that can be produced in large series at a lower cost.
Expensive cabling in the running gear because of the necessary mechanical protection of the cables	Wireless sensor network in the running gear
Energy supply to the sensors via cables from the car body, leading to complex cabling inside the running gear and to the car body.	Sensors with efficient energy management and energy harvesting inside the running gear or even the sensors.
Specific and different solutions for communication and integration in the train level systems exist.	Clear standards for interfaces to train level systems and to maintenance systems enabling compatible running gear sensing.
Self-guiding: Due to wheel conicity, solid axles automatically steer themselves on curves. For independent guided wheels, the guiding mechanism changes the angle of attack to try to maintain wheels parallel to the rails. In service, this simple principle involves some guiding errors that increase noise and wear both in wheels and in rails.	Optimised methods to guide axles and wheels taking into account actual track geometry.
Lateral suspension: Passive oil dampers that decrease amplitude of carbody lateral oscillations.	Semi-active and/or active dampers that react to lateral oscillations, taking into account frequency and actual velocity and displacement of carbody, in order to improve comfort index.

State-of-the-art	New Generation Running Gear
Vertical suspension: Passive oil dampers that decrease amplitude of vertical oscillations of carbody and/or running gear frame.	Semi-active and/or active dampers that react to vertical oscillations, taking into account frequency and actual velocity and displacement of carbody and running gear frame, in order to improve riding quality index.
<p>Virtual certification</p> <p>Today, the authorisation process for putting new rolling stock into service is largely based on full-scale field and line tests, which is expensive, time and capacity consuming. Moreover, it can only be performed at the end of the design process.</p> <p>There is hence a clear need for a reduction of the duration and cost of the process.</p>	<p>Virtual certification</p> <p>The main target is to clearly define a new overall industrial virtual certification process and to unfold it on real cases, demonstrations of the approach (TRL7).</p>

The following table shows the funded projects which have contributed to the development of running gear so far:

Project	Input
<b>MECHATRONIC (1998 – 2001)</b>	Mechatronic technologies for running gear (steering, suspension)
<b>REFRESCO (2013-2016)</b>	Regulatory framework for the use of new structural materials in railway car bodies
<b>EURAXLES (2010-2014)</b>	New design approach for railway wheelsets
<b>DYNOTRAIN (2009-2013)</b>	Virtual certification methods of dynamic performance of railway vehicles
<b>ACOUTRAIN (2011-2014)</b>	Virtual certification methods of acoustic performance of railway vehicles
<b>MODTRAIN (2004-2008)</b>	high speed market with a set of specifications that allow for better inter-changeability of key components for maintenance
<b>INNOTRACK (2010-2013)</b>	innovative methodology for Life Cycle Cost calculation and Reliability Availability Maintainability Safety (RAMS)
<b>ROLL2RAIL (2015-2017)</b>	guidance for selection of technologies with strongest contribution to the S2R overall targets

### 1.5.4.3. Specific Demonstration activities and contribution to ITDs/SPDs

The following table summarises the contribution of TD 1.3 Running Gear to the different SPD's of Shift2Rail:

Research Area	Specific Techn. objective	Specification Activities?	Demonstrator		Focus of activity
			Market	TRL	
Running Gear	Sensing functionality	Universal cost model. Harmonised spec. of running gear of technologies	Metro	6/7	Running gear sensing open standards. Solutions for safety critical and non-safety monitoring systems.
	Optimised Materials		Regional	6/7	New materials for lighter running gear, lower degradation and lower railway system LCC.
	Bogie control		Intercity	6/7	Solutions for suspension & bogie control technologies and their validation
	Noise & Vibration		High Speed	6/7	Validated and refined methodology for prediction and evaluation of new and improved noise control measures

### 1.5.4.4. Impact of the Running Gear Demonstrator

The most significant quantitative benefits to be obtained in relation to the objectives listed in the previous sections are:

- Reduction of bogie associated maintenance costs by up to 20% by enabling monitoring of bogie components.
- Reduction of costs for bogie sensor equipment including their integration in bogies by up to 50%
- Reductions of wheel wear at flange contact of up to 25%, due to a better guidance of axles and due to degradation resistant materials
- Reductions in rail wear due to improved curving performance. Up to 10%
- Improvement of comfort index of up to 15%, due to a better lateral dynamic response of the carbody and an improvement of vertical response to track irregularities.

Each of those specific benefits will contribute on the Shift2Rail system-level KPIs stated in the Master Plan. The relative weight of the benefits provided by this work on the overall system-level KPIs for the whole Shift2Rail initiative are estimated (over a total of 100%) as:

1. Increase of operational reliability (potentially up to 20%): Due to standardized sensorisation, health monitoring functionality, and extensive use of mechatronic solutions, as well as the reduction in wear, improvement in riding quality, reduction of in-service failures and track interventions.
2. Reduction of life-cycle costs (potentially up to 50%): Due to weight reduction, less operational, maintenance related costs, as well as active system control, which they will significantly impact on the wheel and track wear.



3. Increase of capacity (potentially up to 30%): thanks to the reduction of the total weight of a bogie by up to 20%, new generation of vehicle will higher payload.

In order to guarantee a rapid market uptake after Shift2Rail, the following elements has been taken under consideration:

- High TRL demonstrators will be set up in proof and test different running gear solutions
- Common technical standards based on the technologies proposed will be developed

A key contribution from Shift2Rail is to provide new or revised standards for these emerging innovations to ensure they can be certified for future rail contracts, specifically:

- Task 1: Technical specification

Technical specifications: Define the general specification for new running gear layouts (with optional active technology). Specify related high-level architecture and interface requirements.

- Task 2: Sensoring and health monitoring functionality: Address requirements in the recent TSI connected with sensoring in running gears. Identify necessary new standards.
- Task 3: Optimised Materials: There will be standards such as fire, fatigue, or inspection which need to be adapted due to the new materials and their specific characteristics. New standards may be required. An example would be FRP material characteristics (ballast impact).
- Task 4: Active Suspension and control technology: Some requirements of recent TSI, connected with static/dynamic tests to be performed during authorisation of future trains would be updated or modified. Related standards, such as EN 14363 and related, could also be revised accordingly.
- Task 5: Noise and Vibration reduction: This TD will provide valuable input to future revisions of the Noise Technical Specification for Interoperability (TSI) since the running gear is the major contribution to pass-by noise at most normal running speeds.
- Task 7: Virtual certification: The progressive use of simulation in several cases to be defined (cross acceptance, vehicles with small modifications, out-of-the-range modeling of physical tests, etc.) will enable faster and cheaper certification process. One can expect a reduced time-to-market railway offer, more interoperable rolling stocks, cost savings for the stakeholder and the end-users.

Modifications to European standards will be proposed as a result of this activity.

The adaptation of technical standards will have a major impact on the next running gear generations in terms of competitiveness (potentially up to 50%) and reliability (potentially up to 50%). Additionally the technical standards will contribute on a faster development of new running gear as well as faster market introduction. Therefore it can be forecasted that within a period between 2 to 4 years after the end of Shift2Rail project the new developments will be implemented in a significant percentage of all new vehicle projects (estimated in the range 20%-50% of all new projects in Europe and 10%-40% of all new projects world-wide).





### Strategic Impact

The running gear is that which moves and carries the train. Through connecting the carriage to the track the running gear has to transmit all the loads from suspension, traction, braking, curving and guidance for the whole train. It has to deliver this with comfort and safety. The wheel /rail contact patch is optimised for a safe and stable operation whilst minimising wear. The suspensions role extends to defining the gauge of the vehicle to protect the vehicle from the infrastructure. EU manufacturing industry has been closely working together for about 15 years to provide incremental innovations in this area. Shift2Rail goes much further and defines ‘quantum leaps’ in vision, technical advancement and collaborative innovation.

Such developments **support and guarantee the future competitiveness of the EU industry worldwide** by:

#### Technological leadership:

Advances in material technology means EU industry can be the first to deploy in running gear technology. Running gear can represent up to approximately 50% of the tare mass of a train.

- Refinement and standardisation of running gear Sensoring technology captures the market shift towards full lifecycle costing and management of wheel/rail interface. S2R will capture automotive industry experience to lower the cost of these systems.
- Next generation active suspension and curving control can ‘step forward’ and beat the competition to market through collaboration to resolve restrictions to market (including standardisation, certification issues and increased reliability of components, particularly actuators). By enabling this technology the EU industry can visualise the long term future which could include radical new wheel/rail conditions for reduced wear and to allow high speed points and crossings.
- Identifying and involvement of technology leaders from other industries to allow new features and/or speed up the existing supplier landscape.

#### Tangible benefits for the end user:

- Higher speed: – delivered through active curving control and lower weight which enables vehicles to travel faster through existing curves. This can lead to shorter journey times.
- Improved comfort: – delivered by sensor technology which monitors running gear/track condition to highlight issues with comfort as well as having active systems influencing the suspension characteristics.
- Reduced Energy consumption: delivered through optimising running gear structural materials and improved curving performance.
- Reduced Noise and Vibration: delivered through active suspension systems and weight optimised solutions for the unsprung masses

- Reliability and availability: Sensor technology allows health and usage monitoring of the running gear enabling optimised preventative maintenance regimes. Extensive use of mechatronic solutions become possible by breaking down currently existing barriers coming from low reliability of key technological components. Reliability and availability of infrastructure will be improved and hence traffic capacity increased by reduced maintenance demands, resulting from the reduced track damage by lower forces levels on the infrastructure from bogies and wheelsets
- Maintenance Costs: Reduced maintenance costs around the wheel / rail interface can be achieved due to lower wear rates delivered by active suspensions and lower weight and improved wheelset materials.
- Less track damage from bogies and wheelsets imposing lower forces on the infrastructure will reduce maintenance demands on the infrastructure.
- Bringing the solutions to market sooner: by addressing barriers to entry generated by challenges associated with the assessment of these new technologies. The virtual certification task is directly addressing the duration and cost of vehicle authorisation.

The proposed work is **aligned with EU objectives** in the following way:

- Promotion of modal shift: A big impact brought by the implementation of these new technologies towards faster more comfortable trains which minimise service disruptions at optimised cost.
- Support to capacity increase: this is achieved by less service disruptions due to lack of operational availability and by reducing the weight to increase in parallel the amount of passengers.
- Greening of transport: energy savings can be achieved through lighter, optimised materials and improved curving performance.

The proposed work involves a big step in the **degree of maturity of the technologies** to be applied: Currently most of the proposed technologies are in TRL 1,2 (Principles observed and the possibility of using them formulated) . At the end of Shif2Rail it is expected that the successful concepts are brought to TRL6/TRL7

### 1.5.4.5. Implementation of the work programme

#### Scientific and technical methodology and associated work plan

A clear methodology has been devised for the organisation of the technical work in the project, in order to maximize the probability that the desired final objectives are met. This is represented in Figure 26.

**Figure 26: Work plan for Running Gear TD**

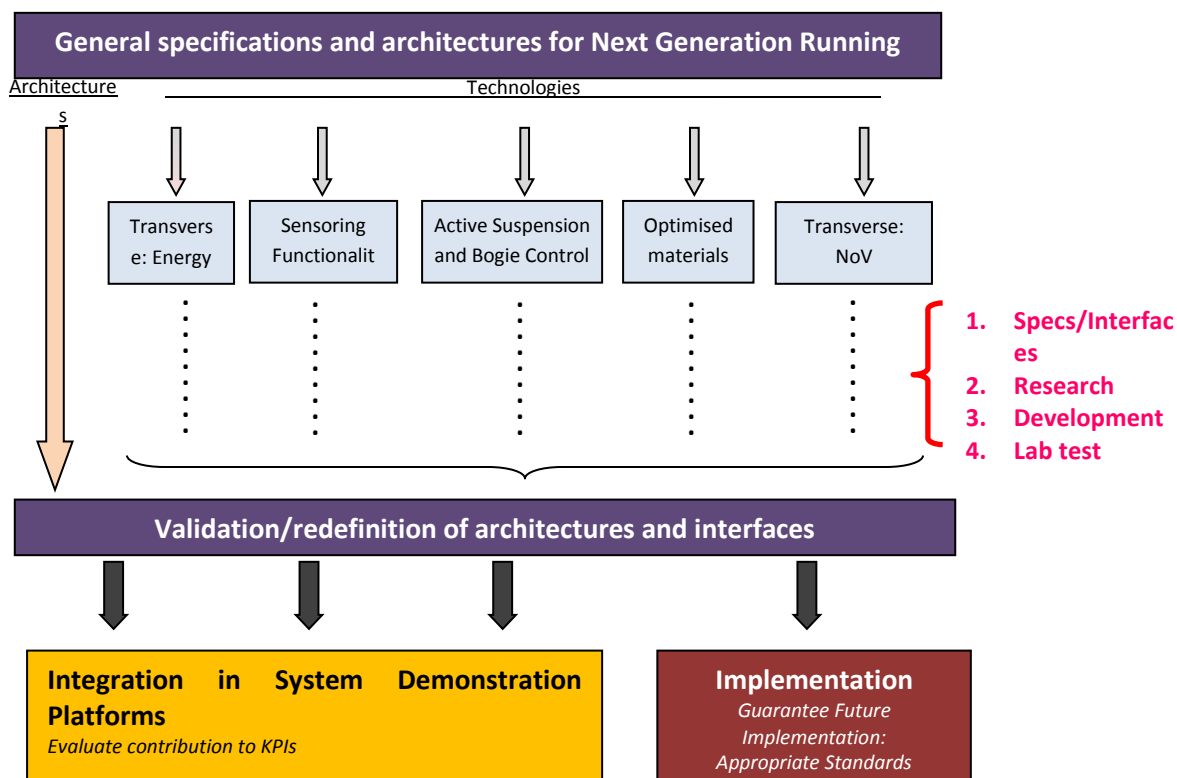

The development of running gear in general involves following main phases:

- Conception of the bogie technology and physical explanation of the bogie behaviour
- Theoretical study and modelling of its dynamic behaviour using simulation models
- Theoretical design and construction
- Testing
- Commissioning and entering into operation

These phases of development are reflected during the programme, from the conceptual phase up to the commissioning (authorisation) and testing phase.

A thorough initial task is proposed looking at general specifications, high level system architectures and interfaces of the running gear of the future, considering the expected features of the technologies to be developed and the needs to be covered.

In a second phase, technologies will be individually developed covering the whole development process from basic research, lower level specifications, technology development, prototypes and lab test, leading to results, showing their performance and to a full knowledge of these technologies.

After technologies have been developed to their full potential and individually assessed, specifications and architectures at whole system level will be re-assessed and the most adequate solutions for the different types of service and operation conditions will be proposed, since selection of bogie technology and design characteristics is directly related to the operational characteristics of the network in which the trains will operate.

This adequate choice of the conception of the bogie technology (conventional bogies, bogies with independently rotating wheels, bogies with auto-oriented axles etc) and the design / constructional characteristics of each one of them (suspension stiffness, wheel diameters, wheel profile, wheelbase) depends directly on the functionality of the vehicles to which they will be mounted on and on the geometrical characteristics of the track they will run on.

This top down approach secures exploitation of commonalities, as well as avoids parallel developments. (See table below with different types of service and operation conditions).

Application	Speed Range [km/h]	Typical minimal Curve Radii [m]
LVR	70-90	25
Metro	90-100	150-300
Regional	140-200	500-1500
Intercity	>200	2000
Locomotives	120-200	500-2000

The final tasks that lead to the project results are twofold:

1. On one hand, a number of different running gear solutions that bring clear contributions to the Shift2Rail global KPIs will be verified in demonstration scenarios.
2. On the other hand, technical standards based on the technologies proposed will be developed in order to promote future deployment. These will also include very detailed definition of interfaces to ensure subsystem interoperability.

Monitoring and key decision making will be managed through the process of gate type reviews at critical milestones throughout the project. A business case approach will be taken throughout the project to focus on the viable target applications.

It is expected that this strategy will effectively guarantee the completion of targets and the deployment of results to the market.



### **Interaction with other TDs (of the same IP and/or of the other IPs):**

The main interaction envisaged, both from the point of view of technologies employed and of interaction in performance and objectives, are:

- IP1 – TD “TCMS”: There is a direct interaction between TD TCMS and task 1 of this TD, sensing functionality. On the one hand, running gear systems processing and sensor signals communicate with train level systems. Some running gear sensors feed directly into the TCMS (e.g. speed, rotational frequency, temperatures). Interfaces including protocols have to be defined and standardised. On the other hand, there are common technologies like wireless communication or energy harvesting which will be analyzed and developed collaboratively.
- IP1 – TD Traction/Braking/Carbody: Running gear weight changes and improved dynamic performance is intrinsically linked to the performance of these systems. For example: acceleration, braking and gauging.
- IP3 – Infrastructure: Next generation passive/active suspension and curving control designs enables radical new thinking in wheel/rail conditions for reduced wear (including RCF) on curved and straight track as well as switches and crossings and to allow high speed points and crossings.
- IP5 – Freight. Technology advances in IP1 read across to be potentially utilised in freight applications.

These links will be explicitly taken into account during the development of the work. Regular contact will be held with the aforementioned groups and specific alignment measures will be taken to ensure consistency

### **Description of Tasks:**

A wide variety of members plan to participate in the following priority tasks of the TD1.4 Running Gear to maximise the probability that the desired final objectives are met

It will do so in collaboration with other members in order to ensure the availability of the relevant complementary expertise and to ensure a wider market uptake of the solutions. Where relevant, the areas where the participation of RU/IM/SME/Universities/Subcontractors is deemed necessary are also specified in.

Details are provided below:

#### **T1.4.1 – Technical specification**

The objective of this task will be to define a harmonized specification of (a) running gear containing the sensorisation, materials and bogie suspension- and steering control. This task is a pre-requisite to the following tasks.

A wide group of members will collaborate in this task.

They will define the general specification for new running gear layouts (with optional active technology). Related high-level architecture and interface requirements will be specified.

Gaps in the existing methods for the assessment of new mechatronic applications will be identified and possible changes or extensions will be defined together with the authorities.

Members will review the specification issued by ROLL2RAIL from a RU/IM/railway operator and maintenance organisation perspective and will validate design notes on key aspects of the bogie system (such as materials selection, preliminary design data, fatigue design parameters)

Open Calls

Additional actors of the supply chain and/or research institutions would be needed to support this task.

#### **T1.4.2 – Sensing and health monitoring functionality**

The objective of this task is to investigate and realize solutions for running gears and their components to enable safety and non-safety relevant monitoring of components conditions. This includes identifying unnecessary requirements from present standards and necessary new standards in order to define clear and agreed common requirements.

A wide group of members will collaborate in this task.

They will research on future open standards, certification requirements and strategy as well as system architecture and components. They will specify targets for optimum sensor qualities such as wireless, energy harvesting, and standard EN interfaces and any encrypted communications protocols. Additionally they will investigate on condition monitoring methods in order to improve vehicle-track interaction for reduced maintenance costs as well as characterisation of track irregularities that correlates with vehicle reactions.

Members will aim at **regional applications**, detailing of information requirements as linked to LCC optimisation as well as development of data assessment and management.

Members will aim at **metro applications** and will develop wireless sensor communications technologies, and then will carry on defining suitable architectures for a system able to detect the status of bogies by collecting data from bogie mounted sensors, and process it into running gear health status information and transfer it to the ground. This system will be specific for in a METRO / SUBURBAN environment, and will be integrated with the TCMS demonstration platform in TD1.2

Members will aim at **intercity applications**, research on robust sensors, signal transmission, energy supply. They will design systems, develop variants of integration into train level systems. They will support laboratory testing and demonstration as well as research on diagnostic methods and algorithms.

Members will:

- Provide feedback on acquired knowledge in the use of existing commercial wireless sensors in a railway environment.
- Provide user requirements on sensor architecture, sensor positioning and data acquisition types and frequency.



- Ensure that key functional aspects are covered in the planned TD activities. Typically these include:
  - Tele-diagnostic features to allow the anticipation of the detection/maintenance/replacement of degraded components (detection performed whilst the train is in service, before the arrival to its final destination),
  - Standardisation of diagnostic events and rationalisation of notifications that are made available to the train driver / maintenance team to allow a more fluid interpretation and controlled influence on the train operations,
  - Standardisation of components across the different bogie systems that will be installed on different train profiles by various train integrators.
  - Perform some of the laboratory tests which will validate the performance levels of key functions
  - Support the writing of the certification process with regards to key aspects that must be properly justified to the National Safety Authorities.
  - Integration of the monitoring architecture and process in the rolling stock maintenance scheme

#### Open Calls

R&D institutions or companies with specific knowledge in areas such as sensors, wireless communications, EMC, vehicle dynamics, condition monitoring, etc. They have to support specifically on the following tasks:

- Research on system architectures
- Development & adoption of sensors
- Development & adoption signal transmission equipment
- Development and adoption of signal processing hard- and software
- Production of prototype systems
- Laboratory and field test of sensors, signal transmission and energy harvesting
- Requirements for sensing from new condition based maintenance concepts.

#### **T1.4.3 – Optimised Materials**

This task will investigate commercial and technical bogie (component) solutions made out of new materials (FRP's, new metal alloys) as well as solutions being enabled/supported by new materials (functional integration, new running gear concepts). A major target is to reduce the weight and especially the unsprung mass to achieve the overall goals for energy consumption reduction and track “friendliness” of railway vehicles.

A wide variety of members will collaborate in this task.

Members will:

- review alternative materials technology and their resulting impact on track damage.
- develop procedures for the assessment of alternative materials in Railway use.
- close the open points from EURAXLES FP7 project by specification of wheelset solutions for the future.
- work on alternative materials and concepts for prime and secondary components.
- Analyse alternative materials for Running Gear related environment.
- work on surface protection technologies as well as development of materials handling, damage analysis, protection, and repair schemes.
- focus in the development of new solution for wheels and wheelsets with special properties to reduce wear and degradation decrease LCC, reduced weight and increase track friendliness. This will be achieved by the investigation of improved materials and coatings and the development of suitable maintenance practices.
- investigate new materials and production process, as well as the associated maintenance equipment, for running gears application allowing achieving a weight reduction up to 20%. The principal goal will be to develop an independent rotating wheel running gear frame using new materials.
- provide knowledge on R&D activities covering the use of new materials and technologies
- contribute to the validation of new designs of optimised axles and components, and their integration in the railway system, including the definition of advanced numerical certification methods as well.
- provide vision of priorities for Running Gear of the future Research on Materials and Designs system architectures.

Open Calls are foreseen for:

- Design, manufacturing and conformity assessment tests for light-weight materials
- Testing of new materials, specimen
- Testing of components

#### **T1.4.4 – Suspension & Bogie control technology**

The goal is to develop and validate new and improved suspension & bogie control technologies:

- a) Steering (auto, passive and active guiding)
- b) Lateral Suspension (semi-active & active)





c) Vertical suspension (semi-active & active)

A wide group of members will collaborate in this task.

They will work on development of specification and assessment procedures for active systems. Additionally they will work on the optimisation of active secondary suspension system, wheel profile design and management as well as development of systems for differentiated track access charges.

Members are expected to work on the development of **wheelset guiding concepts** and **active suspension components** as well as **Bogie Active Control principles** and safety/encrypted communications cases.

They are also expected to research on **Mechatronic Systems** and their application. Additionally they will work on **Active Radial Steering**.

Members are expected to work on the following activities:

- Improvement of passive guiding system for **independent-wheel running gears**, especially for small radius curves found in tracks of emerging and developing countries and for different track gauges.
- New active guiding system for independent-wheel running gears
- Active suspensions for conventional bogies and **independent-wheel running gears**
- Coach active height control system

Members are further expected to contribute to specify, develop, demonstrate and test on line new and improved suspension and bogie control technologies. Assessment of LCC and investment costs, to define clear and agreed requirements, up to TRL7, eg:

- Wheel steering (self, passive or active guiding devices)
- Lateral or vertical suspension (semi active or active devices)

Open Calls will be oriented towards:

- Knowledge on control logic systems.
- Development & adoption of sensors necessary for steering lateral and vertical suspension
- Development & adaption of actuators; hydraulic, electro mechanic components
- Production for prototype systems
- Laboratory and field tests of sensors and components

#### **T1.4.5 – Noise and Vibration**

Methods and tools for an accurate and efficient prediction of needs to be developed and validated in order to systematically optimise the vehicle design and determine the required dynamic properties of the vehicle elements. There are subtasks on structure borne noise, exterior noise and ground



vibration. Each new step in the method development needs to be systematically validated with experimental data from vehicles and lab test.

A wide group of members will collaborate in this task.

The following specific activities will be undertaken:

- Set first targets for N&V for running gear development in S2R in close cooperation with CCA N&V using existing methods and estimates
- Follow up and optimize N&V targets running gear throughout the S2R project in close cooperation with CCA N&V
- Create basic software frame, specification and models for simulating running gear source characterisation as well as air-borne and especially structure-borne noise transmission from running gear to carbody interface and/or interior receiver positions
  - Develop a set of methods that can predict the structure borne noise transmission from wheel/rail contact to the carbody interface, determining in turn the interior noise of the passenger compartment. Combinations of state of the art numerical and empirical methods will be applied (eg TWINS, MBS/FEM software, ACOUTRAIN methods). The methods should be validated and able to predict the effect of introducing variables such as new materials or new improved dampers and couplings in the bogie. This task should be linked to N&V task in the carbody TD and CCA N&V
- Evaluate the effect of measure on the running gear for reduction of exterior noise. Close cooperation with CCA N&V where models for exterior noise will be developed. Detailed studies of simulation methods for combination on new wheel design and special track e.g. slab track or new type of track parameter as studied in IP3 and should be linked. Define combination of vehicle track parameters to optimize.
  - “Exterior noise- skirts”: Development of simulations to rate scenarios introducing skirts on a given bogie in order to reduce the wheel part and the traction part of the noise. Quantify acoustics effect of different novel bogie skirt designs. The influence at higher speeds needs special focus including aeroacoustics effects.
  - “Exterior noise wheels”: Application and validation of methods to predict the noise reduction potential of introducing new integrated means of including damping or otherwise reduce noise radiation from wheels.
  - “Noise effects of active and adaptive bogies”: Tools for evaluating the effect of different configurations of mechatronic bogies regarding curve squeal as well as interior noise
- Evaluate the effect of measure on the running gear for reduction of ground borne vibration. Follow up of RIVAS project. Prediction methods for Ground Vibrations will be developed in the Cross Cutting Activities.
- N&V control solutions developed should be demonstrated on sub-assembly or TD (technical Demonstrator) level.



Members will:

- Develop and validate improved methodology and virtual test for the prediction and evaluation of new N&V measures for interior noise and structure-borne noise transmission. This research process will be coordinated with the N&V CCA group to meet the system design interfaces for N&V transmission.
- Apply on a demonstrator simulation methods developed for ground vibration (in CCA), exterior noise and structure borne noise transmission for interior noise. Elements to be considered are: suspension system e.g. dampers, new materials for bogie, reduced unsprung mass, roughness growth and out of roundness, skirts, aeroacoustic effects, novel wheel designs, curve squeal etc.
- Develop and perform full scale tests of new concept of N&V reduction system specifically oriented to the requirements and operation conditions of METRO/SUBURBAN vehicles

Open Calls are expected in the following areas:

- Support is expected from Universities, Research Institutes and SMEs to perform work in order to develop, validate and implement new enhanced simulation models for prediction of bogie noise in close cooperation with member activities.
- Develop and validate improved methodology and virtual test for the prediction and evaluation of new N&V measures for interior noise and structure-borne noise transmission.

#### **T1.4.6 – Integration in demonstrators/ITDs/SPDs**

Test in real environment and commercial conditions the access systems developed during above projects

A wide variety of members will collaborate in this task by:

- Design-Make-Test a component-system for long term loading and exposure.
- Carry out a bogie monitoring and health status management system demonstration activity in a METRO / SUBURBAN application. This demonstration integrates the sensing and monitoring related developments in task 2 with the developments of TD 1.2 TCMS, resulting in an integrated demonstration activity. The costs of this integration are already considered in TD TCMS, and therefore the budget here is 0.
- Demonstrate new sensing technologies.
- Adapt the technological developments carried out in previous tasks and carry out all necessary steps to make them work in a realistic environment demonstration.
- Perform laboratory tests (e.g. EN13749, EN14363) in an existing test facility on new bogie frames. The following tests could be performed:
- Static structural tests representing in-service and exceptional degraded conditions to check the design

- Fatigue tests using a variety of dynamic loads (10 million cycles in three axes) to check the overall design and manufacturing quality of pre series components.
- Non Destructive tests (Ultrasonic testing, Magnetic testing, penetrant testing)
- Line tests to check the dynamic structural or railway dynamics response of the bogie
- Data processing and analysis of the test results
- Provide recommendations for train path allocation and light (cost and workload) authorisation files to perform on track test of new bogie systems
- Provide advice on modification of the rolling stock under test to act as the test vehicle and its rehabilitation into service after the tests.

Open Calls are expected in the following areas:

- Field Testing / Validation

#### **T1.4.7 – Virtual certification**

- State of the art

Provide a state of the art picture of the railway sector, based on Triotrain results and other research projects. Contribute to an additional bibliography work, notably to analyse the methods and processes that are used in other industrial sectors.

- Numerical models validation

Contribute to the development of new mathematical methods to validate numerical models by comparison with measurements, considering an uncertainty assessment of both the input parameters and the models. Perform tests and/or simulations to validate models with the new method. Data from previous projects could be used.

- Characterisation and modelling of the variability of input parameters

Develop methods to model the distribution of the input data and their effect on the results

Develop a method to define a simplified synthetic track for use in the early stages of simulation acceptance criteria

To be consistent with the statistical approach that will be developed, the way to post-process the numerical results and the acceptance criteria should also evolve.

- Blind tests

Perform the virtual/experimental process on one or two real life case

- Definition of an overall process and recommendations

Contribute to the definition of the processes and verify that they are robust, relevant and that they can be applied, from a technical and organisational point of view (to answer to the following

questions: when can simulations replace tests? Are the necessary input data available at the different steps of the process? How can they be characterised, with which accuracy?)

A wide variety of members will collaborate in this task. An operator member can bring an overall view and expertise for the complete validation process.

Open Calls: No Open Calls are identified

#### **1.5.4.6. Planning and budget:**

TASKS	TRL	2015	2016	2017	2018	2019	2020	2021	2022
<b>TD 1.4 Running Gear</b>									
1.4.1 – Technical specification	3		Roll2Rail						
1.4.2 – Sensing and health monitoring functionality	6/7								
1.4.3 – Optimized Materials	6/7								
1.4.4 – Suspension & Bogie control technology	3/7								
1.4.5 – Noise and Vibration	7								
1.4.6 – Integration in System Demonstration Platform	7								
1.4.7 – Virtual Homologation	3								
1.4.8 – Reporting	-								

The estimated total budget for Running Gear TD is around 26,6M€.

### **1.5.5. TD1.5 Brake Systems Demonstrator**

#### **1.5.5.1. Concept and objectives of the Demonstrator**

The objective of this TD is to develop safe brake systems with higher braking performance, lower life cycle cost and noise levels, as well as braking energy recuperation. Furthermore, lighter, compacter and environmentally friendly brake components and a new generation of brake control electronics will be developed. Improved adhesion management, new generations of eddy current brakes as well as enhanced diagnosis systems for easier and more cost-efficient maintenance are the objectives of this TD.

The following achievements are to be reached by the TD:

1. Ability to implement high safety relevant brake control functions in hardware-software architecture compliant with High Safety Integrity Level (SIL 3-4)
2. Ability to substitute the brake control unit (BCU) communication via railways custom networks (Multifunction Vehicle Bus MVB, Train Control Network TCN) by communication via Ethernet
3. Improvement of braking degradation in poor adhesion condition, from 25% prescribed by UIC 541-05 leaflet to 15%
4. Standardised, interoperable and high safety rated linear eddy current brake
5. Innovative friction pair solutions, lightweight (e.g. ceramic) brake discs, improved LCC
6. Enhanced, failsafe electro-mechanic brake system
7. Standardisation of the assessment brake systems
8. Methods and tools for virtual certification of brake systems

The following table provides an overview over the contribution of the TD against the objectives of the global S2R Master Plan:

S2R Objectives	TD Objectives	Practical contribution (how)
<b>Improved services and customer quality</b>	Elimination of the inaccuracy of pneumatic brake control in safety relevant braking functions, transition of BCU communication protocols from current railways custom networks (MVB, TCN) to Ethernet	System Requirement Specification, System Architecture Specification, Test Specification of sub systems, HW-/SW Prototype, Laboratory and on vehicle system demonstrators
<b>Reduced system costs</b>	Optimisation of adhesion conditions to reduce the braking distances in low adhesion condition, to reduce the wheel's LCC and to improve the overall train safety	Proposals for normative changes, test reports regarding rail wheel contact, mathematical models, adhesion managing concepts and products, standard procedures / test benches for product approval tests
	Eco-friendly maintainability, maintenance costs reduction and diagnosis enhancement of friction brake actuators for compact electro mechanic brake	System requirements, system specification with common standards, interfaces and test procedures, laboratory system solution, on-board vehicle demonstrators
	Reduction of weight and Life-cycle-costs by developing innovative Friction Pair Solutions such as ceramic brake discs for life time operations	Requirement specification, ceramic disc design, validation by lab tests
<b>Enhanced interoperability</b>	Extension of wear-free and adhesion-independent braking with new generation of interoperable linear eddy current brake	Basic design parameters, performance requirements, common standards, interfaces and assessment procedures, lab test results, vehicle test results
<b>Simplified business processes</b>	Reduction of time and cost of the Brake System assessment in a vehicle authorisation	Simplification of Authorisation

### **1.5.5.2. Technical ambition of the Brakes Systems Demonstrator**

#### **Brake Control and Adhesion Management**

In order to achieve the required safety (SIL4 is required on the overall brake system level), today's brake controls still rely on hardwired and/or pneumatic signals and on pneumatic brake controls. This has major disadvantages.

On the one hand, it is not possible to apply more sophisticated braking functionalities, e.g. "train level" blending optimisation, by using these rather rudimentary emergency brake architectures only. Additional electronic control functions and communication networks are necessary for in-service braking as well as for the exchange of diagnostic data. However, these double structures cause higher complexity.

On the other hand, due to intrinsic inaccuracies and to temperature and ageing related drifts, pneumatic controls do not take advantage from the accuracy offered by typical electronic controls. These often produce pressure values lower than the expected resulting in increased braking

distances. Or higher values, which result in overshooting the available adhesion cause sliding. In both cases the braking distances are higher than the expected values. As a consequence, a high safety factor may have to be taken into account in order to ensure that the expected braking distance will be kept. The following example shows a complex state of the art brake control system (figure 27).

These disadvantages underline the immediate demand for improvements to close the backlog to other industries. Those have finally managed to transfer the safety-related functions to an electronic and software-based system architecture which is compliant with the required high Safety Integrity Level (SIL3-SIL4).

This would not only allow taking benefit from the higher accuracy and from advanced emergency braking concepts. It also allows exploiting the advantages of the TCMS to substitute hardwired signals as well as BCU communication protocols of current railways custom networks (MVB, TCN) by using safe communication over Ethernet.

**Figure 27: Example of today's complex brake control concepts, showing different ways of communication modes and pneumatic brake control functions like a two-step, continuously load dependent relay valve (Figure courtesy of Knorr-Bremse)**

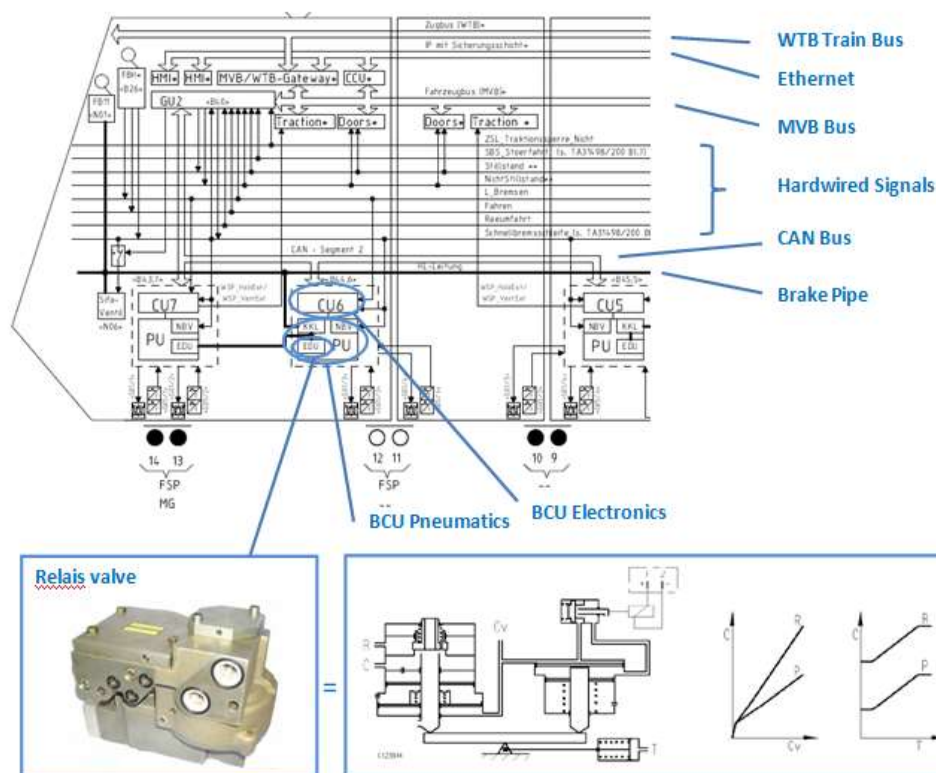

The wheel to rail contact usually not only causes a significant uncertainty when predicting braking distances, but is a general bottleneck with regard to the achievable braking performance of the train and, to a substantial degree, for the traction effort as well. Due to environmental as well as technical reasons the conditions for this wheel to rail contact are very often different and cannot be predicted exactly. They vary depending on different positions of the wheel on the track as well as on different

travel times, seasons, etc. This negatively influences a large number of rail traffic characteristics, like headways, punctuality and especially safety.

Although regulations for brake systems usually consider an adhesion factor of 0.15 only, there will be situations with insufficient adhesion factors. This is different from traction systems, where adhesion levels above 0.20 are allowed to be considered.

A number of strategies can be foreseen to mitigate this situation:

- Sanding as a way to modify the contact conditions
- Wheel slide protection (WSP) as a way to utilize the adhesion maximum currently available
- Additional adhesion-independent brakes, especially magnetic track brakes, but also linear eddy current brakes

Managing especially low or insufficient adhesion conditions can reduce braking distances. Hereby it is important to minimize the variation under comparable conditions. Such a future adhesion management significantly contributes to a capacity increase in railway operation.

In terms of performance, noise generation and LCC the technologies presently used for railway brake systems lag behind the available state of the art. New concepts of an improved adhesion management have to include both a more effective wheel to rail contact as well as improved concepts of WSP. This involves enhanced algorithms and allows a more flexible shifting of slippages and braking efforts along the train.

Considering the strong interdependence of these measures, it becomes obvious that a comprehensive approach is needed.

The massive impact of the wheel to rail contact on braking and traction makes it one of the key factors to increase the performance and the capacity of railway systems.

### **Efficient Braking Force Generation**

It is understood that regenerative braking should be exploited as far as possible as it will become more important in future. However, as it is not in the scope of this TD, the following descriptions will explain the envisaged improvements of other means of braking force generation, which will be necessary to complement electrodynamic braking in the future.

In principal, linear eddy current brakes are already available today and have proven their advantages of adhesion independence, nearly constant braking force at any speed and wear and noise free braking. This has been proven in German ICE3 trains very successfully.

Figure 28 shows how the eddy current brake doubles the available power of wear-free braking and contributes significantly to a high deceleration without adhesion limitation.



**Figure 28: Linear eddy current brake usage in service braking and emergency braking of a HighSpeed train (Figure courtesy of Knorr-Bremse)**

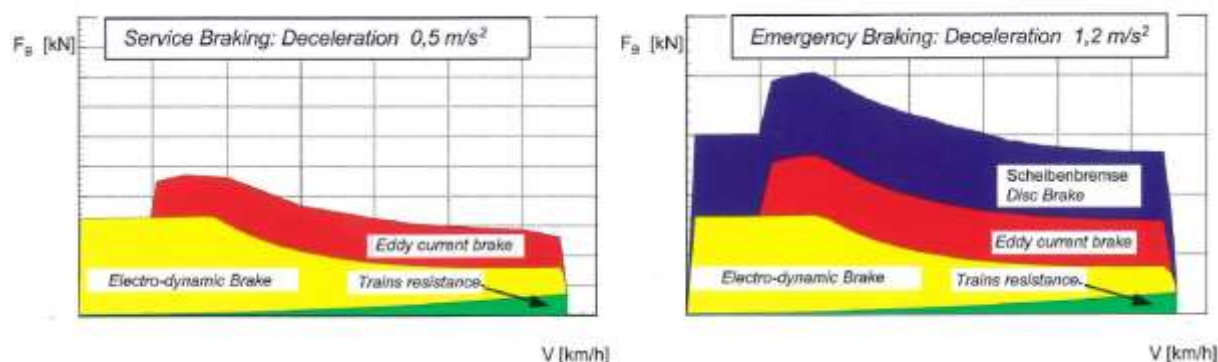

Despite these advantages, the current generation of this technology has not gained significant market share. The main reasons for this are:

- Infrastructure related
  - EMC compatibility (ATP infrastructure)
  - rail heating
- Vehicle related
  - additional interfaces
  - higher energy consumption
  - increased weight

Interaction of current and future eddy current brake technologies with the rail infrastructure is the main topic of the EU FP7 programme ECUC<sup>8</sup>. The achievements of this collaborative project will provide the necessary and sufficient insight view on this area of interest, what remains to be done is the implementation of the results into a new generation eddy current brake concept. In the same way the vehicle related compatibility issues must be addressed in order to improve the acceptance of the eddy current brake technology. A higher degree of standardisation and simplified engineering processes are necessary to support the spreading of the eddy current brake technology into a wider range of vehicles such as intercity trains. Here it could become a promising alternative for magnetic track bound brakes whose braking forces decrease significantly at higher speed. Further on, they are prone to pick up rail material and can also not be used for service braking.

Both magnetic track brake and linear eddy are adhesion-independent brake systems. The advantage of linear eddy current brakes is the frictionless technology, which produces no wear and tear. Nevertheless, it has to be highlighted that it is extremely unlikely that the conventional friction brake can be completely substituted in the foreseeable future so that a further evolution of their state of the art makes sense as well. Today, ceramic brake discs are used in sports cars and luxury class

<sup>8</sup> see <http://www.ecuc.eu/>

limousines of premium suppliers. Compared with conventional grey cast iron brake disc ceramic brake discs weigh around 50 percent less reducing the critical unsprung mass of wheelsets and contribute to reduce the rotating mass.

Further advantages are reduced fading and high thermal stability, high abrasion resistance and therefore a longer lifetime.

The TD aims to design discs that do not have to be changed within the vehicle's life time. This promises a reduction of the overall life cycle cost significantly compensating the relatively high production cost. To achieve this goal, the challenge is to design a system that ensures sufficient heat dissipation.

Looking at the actual friction brake actuator technologies available, it can be said that there are two mature technologies dominating the market:

- Pneumatic systems for high speed trains, regional trains, metros and freight applications
- Hydraulic solutions for light weight vehicles (LRV)

Mainly the hydraulic version has the advantage of high force density whereas the pneumatic one offers a relatively simple activation of the braking power. In any case elaborate concepts of air generation and hydraulic systems are necessary. With regard to ecological and maintenance issues the latter ones are even more demanding. A full drive-by-wire mechatronics brake system could overcome these drawbacks and offer the additional benefits of advanced control, diagnostic functions and ecologically friendly energy storage systems. By using such a system for LRV applications the possibility of eliminating the complete oil management chain would be given. The technology was just not flexible enough to be adapted to the tight frame of requirements for low floor LRVs.

**Figure 29: Electromechanic brake as a basis for a drive-by-wire mechatronic brake system  
(Figure courtesy of Knorr-Bremse)**

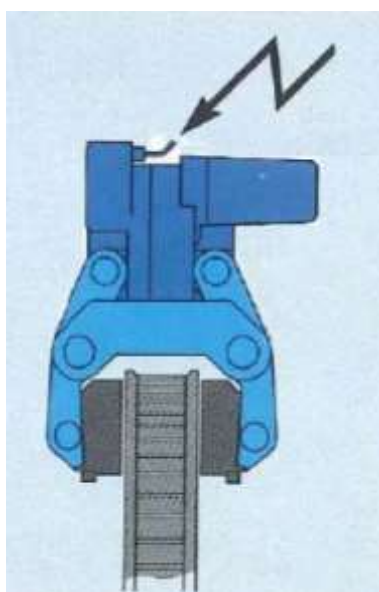

By using the recent experiences in the railway and also other industries, the development of new drive-by-wire mechatronic systems for LRV seems to be possible in the near future. The latest high safety level electronic solutions could promise a safety level that is equal or better than today's hydraulic brake systems. This technology could most likely very soon be introduced to other rail applications, especially to the metro segment.

### **Assessment of Brakes, Virtual certification**

The goal is to create a process for the assessment of brakes with standardised and distinct requirements as well as standardised test programmes defined on a common European basis. The goal is to reduce time and cost of authorisation. By setting these standards the important future aspect of virtual certification will also be taken into account.

This particular work has already been started in the Roll2Rail project. Focus of the Roll2Rail project lies on the analysis of the variety of existing requirements all over Europe and to create the foundation for the following tasks within Shift2Rail.

### **Previously funded projects**

Besides the improvements originating from the ongoing industrial evolution as well as the work being done in various standardisation groups, a number of additional activities were carried out in the past years. Some of them were research projects financed by the European Commission.

A summary is shown in the following table:

Project	Input
<b>FP6 MODTRAIN (2004 – 2007)</b>	Subproject ModBogie: Standardisation of bogie components, partially related to brake, details see <a href="http://www.modtrain.com/subprojects.html#modbogie">http://www.modtrain.com/subprojects.html#modbogie</a>
<b>FP6 MODBRAKE (2006 – 2008)</b>	Innovative Modular Brake Concepts for the Integrated European High-Speed Railway System, details see <a href="http://www.modbrake.com/">http://www.modbrake.com/</a>
<b>FP7 ECUC (2012 – 2015)</b>	Eddy Current Brake Compatibility, details see <a href="http://www.ecuc.eu/">http://www.ecuc.eu/</a>

**Summary:**

The following table summarises how the TD will improve the state-of-the-art brake technologies:

State-of-the-art	New Generation Brake System
Safety braking related functions (safety brake, safety brake weighing) still assigned to traditional pneumatic systems. Due to intrinsic inaccuracy and to temperature and ageing related drifts, the pressure values provided can differ from the expected value which can lead to increasing braking distances or cause sliding.	Electronic HW-/SW platform designed to manage all braking functions (service, holding, emergency, safety brake, wheel slide protection), compliant with the high safety levels SIL3 and SIL4, ensuring a more accurate control.
BCU communication protocols based on current railways custom networks (MVB, TCN), safety related commands being hardwired	Ethernet not as diagnostic media only, but used as full operational communication system according to the required SIL levels.
Significantly changing conditions for the wheel-rail contact, influencing many rail traffic characteristics, including safety and punctuality. Low adhesion causes lower acceleration and longer braking distances, high adhesion results in increased wear and tear and noise. Sanding and WSP are far from the optimum considering the technical options available today.	New technologies help to compensate the variance of the adhesion characteristics and, combined with a more sophisticated WSP technology, allow reducing the braking distances in bad adhesion conditions and to improve the overall train safety, finally reducing the wheel's LCC.
A linear ECB exists, but suffers from unsolved track compatibility problems and other disadvantages (complicated interfaces to the vehicle, higher energy consumption and weight). These are the main reasons it is currently deployed in German high speed trains only.	The new generation linear ECB is compliant with the compatibility guidelines (ECUC) and has well accepted interfaces and features. It is mature for interoperable employment of adhesion-independent, silent and wear and tear free eddy current braking.
Ceramic brake discs are actually used on an automotive sector premium level only.	Ceramic brake discs are also introduced to the railway business reducing the life cycle costs significantly by providing a life time design.
LRVs use hydraulic friction brakes, while high speed, regional, metro and freight use pneumatic technology. Electromagnetic brakes are not compatible with the space requirements of hydraulic LRV brake systems and are not competitive against pneumatic friction brakes.	Electromechanical friction brakes are as compact as to substitute the hydraulics in LRVs and competitive enough to be introduced to other vehicle types, allowing better control and diagnosis.
Time consuming and costly assessment due to high complexity of European plus national regulations, inconsistencies and/or interpretation divergences.	Definition of an assessment process, with standardised and EU-wide accepted criteria including a standardised test programme in order to reduce the time and cost for authorisation.

**1.5.5.3. Specific demonstration activities and contribution to ITDs/SPDs**

The following table summarises the contribution of TD 1.5 Brakes to the different ITDs of Shift2Rail:

Re-search Area	Specific Techn. objective	Specification Activities?	Demonstrator		Focus and result of activity
			Market	TRL	
Brakes	Higher SIL electronics	Requirement, standardised criteria and implement. strategy for assessment	Generic	4	Transfer brake safety functions from traditional pneumatic components to SIL3-4 compliant electronics
	Adhesion Management		Generic	4	Better understanding of adhesion to derive new solutions for optimal use New adhesion control concepts to compensate the constant change of the wheel to rail conditions
	Next generation Eddy-curr. brake		Intercity	6/7	New ECB solving challenges such as track compatibility, standard interfaces & energy consumption
	Innovative Friction Pair Solutions		Generic	4	Ceramic brake discs solutions for rolling stock as well as a single ceramic brake. Innovative steel disks solutions improving friction pair LCC
	Electromech. Brake		Generic	4	New drive-by-wire mechatronic brake actuator for railway applications
	Authorisation Process		Generic	4	Requirements, standardized criteria and implementation strategy for future assessment incl. virtual certification

#### 1.5.5.4. Impact of the Brakes System Demonstrator

The most significant quantitative benefits that result from the activities and objectives listed in the previous sections are:

- Capacity increase (train-track) by up to 20%
- Reduction of in service failures (brake system only) by up to 15%
- Reduction of LCC (w/o energy consumption, brake system only) by up to 60%

It has to be said that these figures are based on assumptions and can be affected by criteria that have their origins beyond the brake system.

Strategic Aspect	Key Contribution from the TD
Support the competitiveness of the EU industry	<ul style="list-style-type: none"> <li>• Technological leadership supported by a combination of               <ul style="list-style-type: none"> <li>○ radical innovation (high safety level electronic solutions finally leaving behind the remains of our ancestors' brake system, quasi elimination of the bottleneck of low adhesion)</li> <li>○ exploiting technological enhancements in related systems (e.g. TCMS, TD1.2)</li> </ul> </li> <li>• Tangible benefits for the end user:               <ul style="list-style-type: none"> <li>○ Increase of operational reliability through less operation restrictions under poor adhesion and through better diagnostics of the brake components</li> <li>○ Support capacity increase through higher track throughput enabled by shorter and/or more reliable braking distances</li> <li>○ LCC reduction due to better diagnostics, lower energy consumption and introduction of life time brake components</li> </ul> </li> </ul>
Compliance with EU objectives	<ul style="list-style-type: none"> <li>• Promotion of a modal shift by implementation of these new technologies to help avoiding service disruptions and adding new features</li> <li>• Support the increase of the capacity</li> <li>• Greening of the rail transport through reduction of the energy consumption by reducing the rotating mass of brake discs.,</li> <li>• Elimination of any oil in LRV brake systems</li> </ul>
Degree of maturity of the envisaged solutions	<ul style="list-style-type: none"> <li>• High safety relevant brake control functions in hardware-software architecture</li> <li>• Brake distance degradation improvement</li> <li>• Development of the next generation linear eddy current brake</li> <li>• Development of a weight reducing life time Ceramic brake disc</li> <li>• Development of a drive-by-wire, mechatronic brake actuator</li> <li>• Reduction of Time and Cost of Brake System Assessment</li> </ul>

The evolution of the brake system capabilities may deviate from the requirements of the relevant TSIs: TSI LOC&PAS and other TSIs, such as Control, Command and Signalling (CCS, length and tolerance of braking distances) or Infrastructure (INF, eddy current brake). Those TSIs may need to be reviewed to incorporate innovative solutions.

Correspondingly, related standards on the brake system level, e.g. EN16185 (Multiple Units) or EN14352 (Mass transit), as well as on the subsystem level, e.g. EN15595 (Wheel slide protection), need to include the new concepts proposed in this TD.

The outcome of the FP7 funded ECUC project defining standards for eddy current brake compatibility needs to be integrated in the standardisation framework.

### 1.5.5.5. Implementation of the work programme

A clear methodology has been devised for the organisation of the technical work in the project illustrated in figure 30:

**Figure 30: Methodology (Figure courtesy of Knorr-Bremse)**

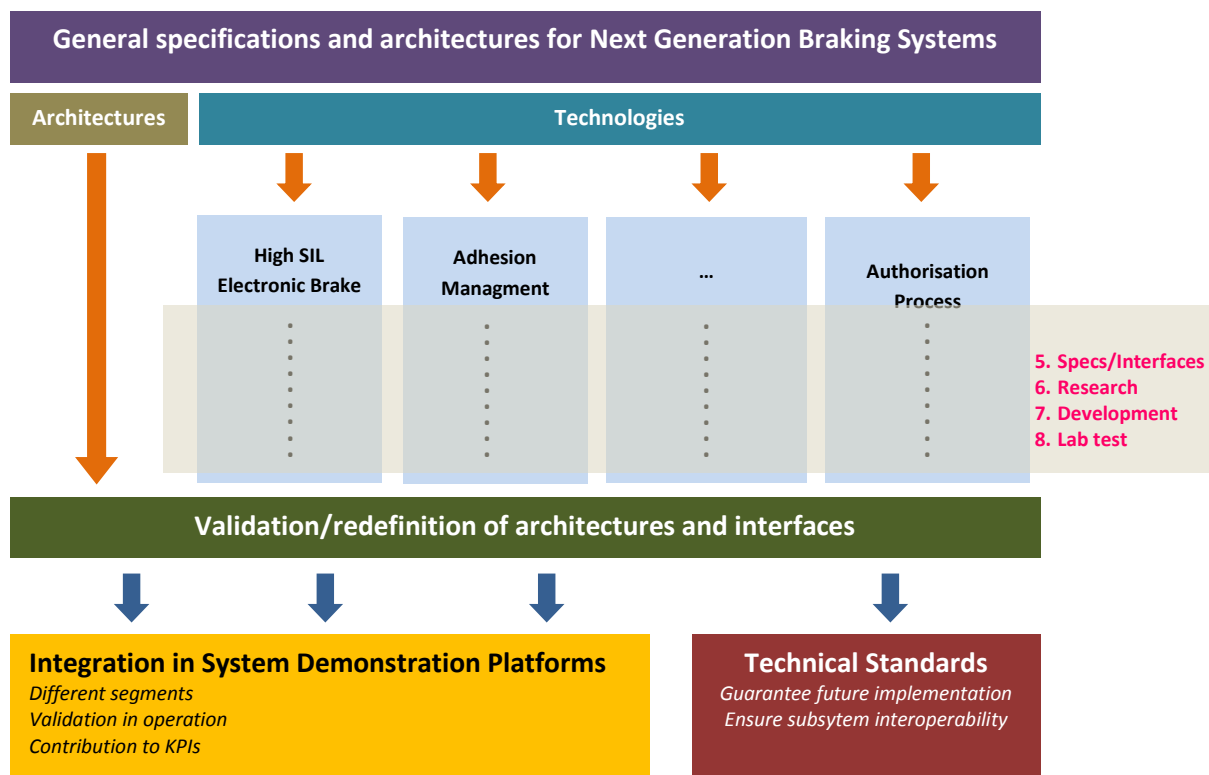

An initial task is proposed to investigate the necessary features, use cases, conditions and requirements, general specifications, high-level system architectures as well as internal and external interfaces for future brake systems.

In a second phase, technologies will be developed individually covering the whole development process from basic research, lower level specifications, technology development, prototypes and lab test, leading to results showing their performance and to a full knowledge of these technologies.

After the new technologies will have been tapped up to their full potential and also individually assessed, specifications and architectures at the entire system level will be re-assessed and the most adequate solutions for the different types of services and operation conditions will be proposed.

The tasks that contribute to reach the project targets are twofold:

1. A number of different brake applications that contribute to the global KPIs of Shift2Rail will be demonstrated in one or more system demonstration platforms
2. Technical standards based on the architectures and technologies proposed will be set in order to promote future deployment. These will also include very detailed definitions of interfaces to ensure interoperability of subsystems.

Monitoring and decision-making will be managed throughout the process of gate type reviews at critical milestones of the project. A business case approach will be used during the entire project to focus on the viable target applications.

**Figure 31: General Development Process Flow (Figure courtesy of Faiveley Transport)**

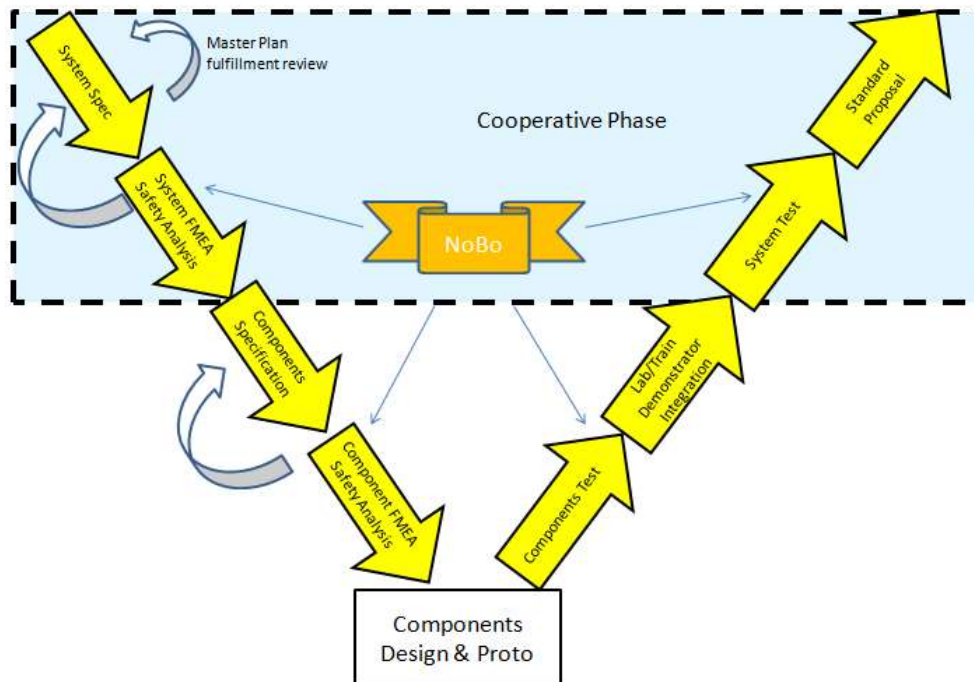

In order to maximize the collaboration and synergy between industries and, at the same time, to protect the own know-how and intellectual properties, the following general process is proposed:

1. Brake System Specifications, gap analysis between state-of-the-art and innovative systems, identification of major differences and added risks on safety and performances, impacts on vehicle authorisation, introduction and interoperability with existing fleet.
2. System FMEA and related System Safety Analysis, SIL attribution to the new technologies/functions/components.
3. Lab/Train Demonstrator Test Specifications for innovative Brake Systems validation
4. Innovative Components FMEA, Design and Test Specifications
5. Components design, prototyping, test according to 4.
6. Integration on Lab/Train Demonstrator and tests according to 3.
7. Standardisation proposal

The items 1, 2, 3, 6, and 7 will be executed in a **collaborative** way among the partners, ensuring that shared/interoperable solutions as well as standardised tests procedures can be defined. This will eventually result in consistent proposals for standards,

Items 4 and 5 will be executed in a **competitive** way, protecting the partners own know-how.



The involvement of NoBo/Safety will ensure that the processes as assessed fulfil the safety requirements at system level. By doing this the development of non-safety compliant architectures and solutions can be avoided.

This strategy does guarantee that the targets set for the development can be reached and the new product can be successfully deployed to the market.

#### **Interaction with other TDs (of the same IP and/or of the other IPs):**

##### **IP1 TD1, Traction:**

There is a strong interdependence between acceleration and deceleration. Blending technologies and use of ED brake are examples of a tight interaction between traction and braking.

##### **IP1 TD2, TCMS:**

The TCMS is the backbone for the transmission of safety relevant information in a train. Therefore all relevant brake control information has to be exchanged in the TCMS, which is essential for advanced braking concepts.

The development of an Ethernet based TCMS for high safety level brake functions can be applied to future brake control systems.

##### **IP1 TD4, Running Gear:**

It is essential to exchange the state of the art of both subsystems since the bogie is the place where most of the mechanical part of the brake is built-in.

Therefore a close interaction between the two TDs is essential to optimize the future design of brake mechanics in the bogie.

##### **IP5 TD1, Electrification:**

Future brake systems for freight applications will be developed in IP5, TD1. There are some technical areas which are common in IP5, TD1 and in IP1, TD5, such as tread brakes used for metros and for freight cars or locomotive driven trains for passengers and freight.

This also requires an exchange of information between the two IPs.

##### **IP3 TD3, Optimised Track System; IP3 TD4, Next Generation Track System:**

The next generation eddy current brake has to be compliant to the track system of the future. To ensure this a coordinated approach between the two IPs is needed.

#### **Description of Tasks:**

##### **Task 1.5.1 – High Safety Level electronic Solutions for Brake Control**

The aim of this task is to develop an electronic hardware-software architecture, compliant with High Safety Integrity Level (SIL3-SIL4), particularly oriented to be applied in Brake Control solutions, where the safety functions allocation will be transferred from traditional pneumatic components to

electronic modules (up to TRL 4). The task will be performed according to Figure 31 (General Development Process Flow).

The members will:

- Participate in the requirements and specification phase, especially with regard to the classification of functions regarding their safety relevance
- Provide support during the realisation phase by assessing the achievements against the targeted implementation level.
- Ensure consistency with the requirements for the fail safe electronics to be developed in the TD1.2 TCMS. In particular, a metro and suburban application is intended to be integrated. The budget for such an integrated demonstration application has been planned in the TD1.2.
- Define the criteria the assessment of higher safety level electronics.
- Contribute to work out a joint overall concept for high safety level electronics considering the requirement's catalogue of the generic task description.
- Review the proposed brake control and communication architectures using IT systems and identify incompatibilities with other systems within the overall railway system.

The leading member of this task will elaborate the system requirements, test specification, system FMEA, safety analysis, prototype and a laboratory demonstrator. It is planned to install this new mechatronic system on a real demonstrator in order to show the performances that can be achieved.

These test results will be evaluated and validated and can be used for the impact assessment of the TD.

#### Open Calls:

Definition of criteria for the assessment of higher safety level electronics through notified bodies, a task which needs experts in the field of rolling stock certification who have dedicated know-how of the demands on safety for electronics.

NoBo's who have competencies in the automotive or avionics sector are preferred. They can contribute their safety specific transversal knowledge which will be useful to improve and simplify the railways sector's technology with its specific safety requirements.

#### **Task 1.5.2 – Adhesion Management Improvement**

The first objective of this task is to map different adhesion conditions occurring in the rail traffic.

The analysis will result in new performance's specifications for adhesion recovery systems. Furthermore, improved requirements for WSP test procedures will be generated, followed by new specifications for automatic test benches. In particular, such WSP test bench specification should result in the definition of a standardized and well adopted methodology for the Virtual certification of WSP (please also refer to 1.5.6. vehicle Authorisation Process; e.g. test vehicle mathematical model, various adhesion models library, etc.)



Subsequently the effect of the modified basic adhesion methods should be investigated using test rigs, simulations and trial runs. Based on the results, new products will be designed and possibly developed. These should enable to optimize the braking distances in low adhesion condition, to ensure the overall train safety, and to reduce wheels LCC (up to TRL 4).

The task will be performed according to the General Development Process Flow (Figure 31) by a variety of members providing the appropriate skills and experiences.

The members will:

- Participate in the requirements and specifications generation phase for such a system.
- Provide support during the initial collaborative work of collecting data and their consolidation which is needed to defining requirements and specifications and finally to create a proposal for future adhesion management methods.
- Develop a preferable concept for the implementation of the collaborative part, mainly targeting the implementation in suburban or urban train applications.
- Participate in the initial collaborative work of mapping known adhesion conditions and contribute to the theoretical and experimental investigation of adhesion modification methods. Develop innovative slide protection algorithms based on the findings during the collaborative part, in particular in metro and suburban environments. Tests will then be performed using the high safety level electronics (TCMS SIL) developed in TD2.
- Give support to elaborating the system requirement's specification, test specification, system FMEA and safety analysis. In addition a new adhesion system will be proposed and tested, if possible using a test bench which allows implementing the developed vehicle models and adhesion libraries. The development of such a test bench would also prove the equivalence and interoperability of the virtual certification process that will specifically be developed within this task.
- Contribute to establishing a joint overall concept for high safety level electronic considering the requirements catalogue as stipulated in the generic task description
- Review the proposed low adhesion management approaches and assess their contribution to reduce braking distances in normal and specific operating conditions (braking in winter, with dirt and leaves on the track, etc.).

The Members will deliver the specifications, system FMEA, safety analysis, test reports on rail wheel contact, mathematical models, adhesion managing concepts & prototypes, procedures and test rigs for R&D, a demonstrator and the product approval tests and proposals for normative changes.

#### Scope of Open Calls:

Scientific institutes' and research laboratories' support is needed to prepare the test procedures, to perform the tests and to evaluate the results.

It will also be necessary to identify topics in terms of the current standards and regulations, which have to be adjusted to optimise braking in poor adhesion conditions. Additional support and expertise by the dedicated standardisation bodies is needed to trigger these normative changes.

### **Task 1.5.3 – Next Generation Linear Eddy Current Brake (LECB)**

Development of the next generation linear eddy current brake with a clearly defined interface to the vehicle's traction power supply. A major requirement is to have an independent brake system which offers the same safety level as existing friction brakes. Future interfaces between the train control and the eddy current brakes are to be adopted. A more standardized and easy to engineer eddy current braking technology ready to be deployed into a wider range of vehicles is targeted. One example are intercity train applications which will be developed up to TRL 6/7. The task will be performed according to the General Development Process Flow (Figure 31) by a variety of members providing the appropriate skills and experiences.

The members will:

- Participate in the requirements and specification elaboration phase for such a system.
- Contribute to the definition of the requirements for interfaces and support the conceptual work with the aim to widen the spectrum of possible applications of the linear eddy current brake in rail vehicles.
- Contribute to the creation of a joint overall concept including a requirements catalogue for the next generation of linear eddy current brake.

Members will deliver and evaluate the basic design parameters, the system FMEA and the safety analysis, a system specification with standards, the interfaces and assessment procedures, the lab demonstrator, the lab test results, the tests on the vehicle and the test results. Furthermore, will contribute to the evaluation of the safety related parameters and the LCC and to investigate if this type of a brake system would be compatible with the specific traffic conditions of a railway section.

#### **Scope of Open Calls:**

Authorisation expertise for the certification of the whole system, and know-how in the infrastructure (signalling and track) and traffic management related functions of the rail system will be necessary to perform the task.

In addition, expertise on electro-magnetic compatibility requirements, specification, test procedures, and test evaluation methods are needed.

### **Task 1.5.4 – Innovative Friction Pair Solutions**

Development and design of a new generation of disk and friction materials' based brake system that can be applied for friction pairs as well as for a single ceramic brake (CB) up to TRL4 of rail vehicles. The task will be performed according to the General Development Process (Figure 31) by members providing the appropriate skills and experience to perform the task.

Reduction of weight and life cycle cost will be the main impact that can be expected.



The members will:

- Contribute to the collection and consolidation of the requirements and will participate in the assessment of the targeted concepts.
- Participate in the definition of the specifications and tests procedures. In addition, they will test the new brake disk technologies and provide dynamometers for LCC tests in the laboratory.
- Contribute to the elaboration of tests specifications in order to investigate the safety aspects in the case of an emergency brake as well as during regular service braking .  
A further task will be to analyse the results and to evaluate the economic benefits in comparison with steel and cast iron disks.

The Members have to establish a joint overall concept for ceramic brake discs based on a requirements catalogue. He will develop the concept and the description of the final technical solution and finally a ceramic brake disk prototype.

#### Open Calls:

Scientific institute's or research lab's expertise is needed for the specific research work to undertaken in order to select and validate the available ceramic or comparable materials. They have to support the transfer of existing applications and new manufacturing technologies from other industries, such as the automotive industry. Finally, they will contribute to the preparation of tests and the evaluation and validation of the results.

#### **Task 1.5.5 – Electro-Mechanic Brake for Railway Applications**

Development of a drive-by-wire, mechatronic brake actuator for railway applications. The first applications targeted are light rail vehicles (LRV), but also metro and regional railway applications are in the scope of this task (up to TRL 4). Reference has to be taken to the results of task 1.5.1, in terms of the safety impacts introduced by an electromechanical brake system.

The task will be performed according to the General Development Process (Figure 31) by members providing the appropriate skills and experience to perform the task.

The Members will:

- Contribute to the definition of the general requirements and specifications for the different vehicle classes (LRV and metro). They will find solutions to assess the feasibility of the new concepts. and draft an implementation strategy of electromechanical actuators considering the interfaces and required performances for those specific applications.
- Participate in the definition of the basic design parameters, requirement's specification, lab demonstrator and the evaluation of the lab test results.
- Create a joint overall concept for electro-mechanic brake with a requirement's catalogue and a concept for the realisation. They will also design an electro mechanic brake system and demonstrate it's functionality.



- Contribute to the evaluation that an electric drive has no negative influence on the safety features of the system and that the LCC improve compared with hydraulic actuators.

The Members will be responsible to deliver the system requirements specification, test specification, system FMEA, safety analysis, the prototype and a laboratory demonstrator. Finally, the test results will be evaluated. The Members will also be responsible for the provision of a lab demonstrator.

Open Calls are intended to be placed targeting companies that have competencies in electrical energy storage systems and, like in task 1.5.1, for NoBo's which may have to support in the definition of assessment criteria and the related test procedures.

#### **Task 1.5.6 – Vehicle Authorisation Process**

Based on the results of the analysis undertaken in the Roll2Rail project the requirements, the standardized criteria and an implementation strategy for assessment of future brake systems (up to TRL 4) will be defined. In addition, new methods and their implementation strategies for the virtual certification of brake systems will be investigated and defined.

The task will be performed in a collaborative way by different members providing appropriate skills and experiences.

The Members will:

- Contribute to drafting different authorisation strategies and to defining assessment plans for them.
- Contribute to defining a common overall process for the assessment of brake systems for all countries in the European Union. In particular with regard to a requirement's catalogue for standard test procedures.
- Provide expertise with regard to the specification and assessment of new or upgraded technologies.

The Members will be responsible for the delivery of a description of standard design requirements, and test procedures. In addition, methods for the system integration and a standardized documentation for the authorisation process will have to be defined. Finally, expertise in using simulations and bench tests as part of the virtual certification has to be contributed.

#### **Open Calls:**

Authorisation expertise for an overall authorisation management has to be added including the investigation and evaluation and integration of the results of the Roll2Rail project.

In particular the transfer of the harmonised findings and implementation processes to the relevant standardisation and regulation bodies has to be ensured.

Furthermore, expertise in virtual certification of systems and subsystems is needed to complete the task successfully.

### 1.5.5.6. Planning and budget:

TDs	TASKS	TRL	2015	2016	2017	2018	2019	2020	2021	2022	2023
<b>TD1.5</b>	<b>BRAKES</b>										
	1.5.1 High Safety Level electronic Solutions for Brake Control	4									
	1.5.2 Adhesion Management Improvement	4									
	1.5.3 Next Generation Linear Eddy Current Brake	6/7									
	1.5.4 Innovative Friction Pair Solutions	4									
	1.5.5 Electro-Mechanic Brake for Railway Applications	4									
	1.5.6 Homologation Process	4									

The estimated total budget for Brakes TD is around 31,8 M€.

### 1.5.6. TD1.6: Doors and Access Systems Demonstrator

#### 1.5.6.1. Concept and objectives of the Doors and Access Systems Demonstrator

Train access systems such as doors but also steps and ramps are the key interfaces between station platforms and trains for passengers. They enable passengers to board the train and also have other functions, as they:

- Contribute to the comfort
- Optimize the dwell time consumption to getting on and off the train
- Support the demands of people with reduced mobility (PRM)
- Guarantee the passenger safety

In order to propose innovative and competitive solutions that are in line with the aforesaid needs, the TD Doors mainly targets three technical topics which will generate real added value to the European railway industry:

#### 1. Weight and energy optimisation:

Each additional kilogram of mass on a train causes:

- More energy consumption to move the train and more braking effort to stop it
- Earlier wear of the mechanical part of the brake system and the track
- Less passenger capacity

Lighter doors will directly address the Master Plan's objectives. Faster opening and closing to increase the passenger flow, higher passenger load (mainly for metro) to enhance the train capacity and less track and train equipment wear and tear reducing the operating cost will be the result.

Although the mass of state of the art doors has already been optimised based on the existing technologies, there is still room for improvement. Thanks to the introduction of new materials and

technologies not yet widely used in the railway sector, the TD doors will be able to develop a lighter and less power consuming access system.

## **2. Thermal and acoustic performance improvement:**

A rail vehicle door is a major factor in terms of thermal and acoustic comfort for passengers. It can act as an intelligent physical barrier in order to reduce waste of energy when passengers embark or disembark a train.

Today, the comfort in the proximity of doors and vestibules can be negatively influenced by noise and low temperatures. Noise can hinder passengers to communicate by phone. Low temperatures near the door can cause condensed or even frozen water at the bottom of the door.

Operator's and vehicle manufacturer's requirements are getting more and more ambitious. However, existing solutions such as insulation skins are too heavy, expensive and complicated which makes it difficult to comply with these requirements.

Therefore, the TD Doors aims at finding technical breakthroughs to address two objectives of the Master Plan:

- Creation of a unique passenger experience on the train
- Enable a smooth passenger flow between platforms and trains

## **3. Autonomous interoperable access for PRM <sup>(\*)</sup> safety and door surveillance solutions**

*(\*) A Person with Reduced Mobility is anyone travelling by train but facing difficulties to access the train.*

The door system is the key to ease access **for all passengers, including PRM**. Gaps and height differences between train and platform is one of the main reasons that is limiting the mobility of PRM.

In 2014, SNCF received 425.000 requests for assistance by PRM passengers, thereof 35% especially for wheelchair users. The demand for such kind of support has increased by 10% annually since 2009.

To assist the boarding of persons using a wheelchair a dedicated manual ramp or lift is necessary. This procedure is hindering the autonomy of PRM, requires dedicated resources and can have a negative impact on the train schedule. Therefore, a solution that allows an easy access for PRM without additional assistance is necessary. Hereby it should also be considered to provide features that aid partially sighted or passengers with hearing difficulties.

Hence, doors need to be more interactive with passengers, will offer real time visual or sound information to improve the guidance of passengers and to positively contribute to their overall travel experience. Such a smart and "communicating" door will enhance the flow of all passengers and significantly contribute to the **capacity increase of train systems**.

It is also worth mentioning that the actual solutions for PRM like buzzers and beacons might disturb the surrounding areas, as they can be very noisy.





New door systems have to strictly comply with the PRM TSI revision 2014 and also must address the described noise challenges. They have to follow the pre-requisites for enhanced interoperability and the TSI regulations, both defined as objectives of the Master Plan.

Finally, it should be highlighted that for all new functionalities developed within the tasks described above (weight reduction, comfort improvement and PRM solutions), the modularity of the new door systems and the optimisation of their installation time will be pre-requisites.

Modular door systems would facilitate future evolutions, maintenance and repair activities which would contribute to reduce LCC. A plug and play approach for the different devices would improve the standard of their connectivity, enabling easier obsolescence management and finally widen the range of different configurations.

Corresponding requirements on modularity and installation time will be defined accordingly.

To summarize, the goal of the IP1 TD Doors is to generate added value for customers, vehicle manufacturers and passengers in terms of:

- Comfort improvement with regard to acoustic and thermal performance
- Person with Reduced Mobility (PRM) solutions,
- Energy consumption and axle load optimisation
- Modularity of the systems.

**Technological outputs to be delivered by this TD:**

The following table shows how the proposed activities will contribute to the achievement of S2R objectives as stated in the S2R MP:

S2R Objectives	TD Objectives	Practicable contribution (how)
Improved services and customer quality	<p>Passengers comfort improvement and enhanced passenger experience, including PRMs</p> <p>Increased capacity due to improved passenger flow by introducing innovative passenger access systems.</p>	<p>New architectures, new materials and technologies for an optimised access solution (thermal, acoustic performances and weight)</p> <p>Contactless passengers detection by using new sensor technologies</p> <p>Innovative vehicle access systems allowing independent and faster boarding for all passengers</p>
Reduced system cost	<p>Weight &amp; energy optimisation</p> <p>LCC reduction</p>	<p>Significant weight reduction for the access system by using new materials and applying new assembly processes</p> <p>LCC reduction through a higher degree of modularity of the door</p>
Enhanced interoperability	Comply with PRM TSI and address the open point related to the diversity of interoperable platforms	Adaptive steps and platform detection

**1.5.6.2. Technical ambition of the Doors and Access Systems Demonstrator**

Train access systems are complex subsystems which are critical for the availability and functionality of trains. Continuous measures for improvement have been taken during the last years. Several publicly funded collaborative R&D projects were carried out.

A summary is shown in the following table:

Project	Outputs
<b>BPI (ex. OSEO) Defi Composite</b>	Composite material high speed leaf
<b>FEDER porte du future</b>	<p>New door control unit compliant with new market requirements (anti-drag, obstacle detection, EN 14752, EN 50128, ...)</p> <p>Ultra-flat sliding step</p> <p>New platform detection system</p>

In 1965, the first automatic door was introduced to the market, improving the system significantly. They were based on pneumatic actuators and controls. Together with the continuous electrification some important new features could be introduced:

- More precise detection of obstacles
- Complete replacement of compressed air
- Easier maintenance (no filter cleaning, no leakage),
- Better reliability mainly due to the introduction of electrically driven valves

Gradually, the door systems have become high-technology products, reaching new performance levels that make them able to run a constantly increasing number of functionalities.

However, there are still gaps between the features offered by the existing door systems and the demands from vehicle manufacturers, operators and passengers.

#### **Door leaf state-of-the-art:**

The state-of-the-art architecture of a door leaf is as simple as shown below.

The leaf structure is composed of aluminium profiles, located on the external borders of the leaf, mainly ensuring the leaf mechanical resistance:

**Figure 32: Usual principles of leaf conception**



Two skins (inner and outer) are covering the profiles and the filling (foam, honeycomb, etc.).

**Figure 33: Leaf structure**

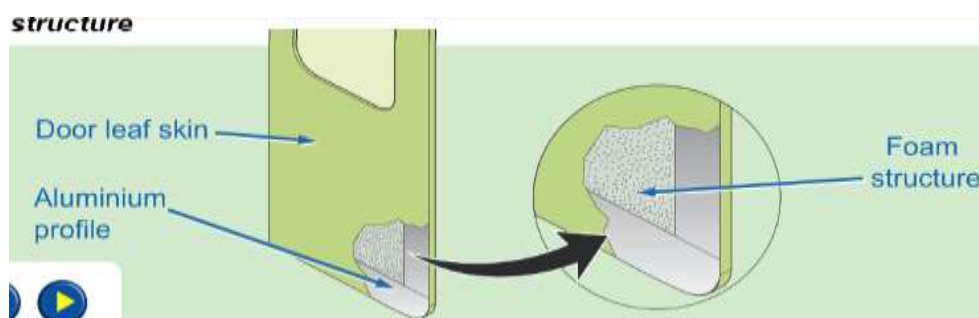

The two sheets are glued on the profiles and the inside material. The bonding guarantees the mechanical link between the two sheets and also increases the leaf stiffness.

**Figure 34: Leaf assembly by bonding**

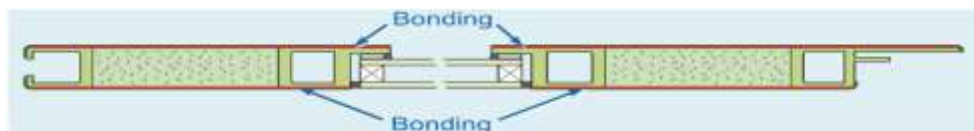

At present this architecture is considered as the optimal solution but there are still pros and cons to be considered.

Since it is very simple, it is little cost consuming but there are weaknesses in terms of acoustics, thermal behaviour and weight.

The foam structure is made of rigid foam with closed cells, which ensures a constant distance between inner and outer skins, similar to a “sandwich” assembly.

This cost efficient solution is widely proven in commercial services. However, the performance in terms of acoustics is weak, downgrading the overall performance of the entire door.

The same conclusion can be drawn with regard to the thermal behaviour of the door structure. Since the leaf profiles are made from aluminium, they are transmitting heat. This effect cannot completely be avoided even when using high grade thermal foam.

Finally, the leaf architecture is not yet mechanically optimised which increases the weight of the assembly.

The conclusion is that actual leaf architectures are optimised in terms of process assembly and cost competitiveness but it contains drawbacks concerning the thermal and acoustic performance and increases the weight of doors.

The TD Doors aims to eliminate those drawbacks by using new materials or new assembly processes. The introduction of composite materials to rail vehicle doors would be one of a number of measures to improve the situation.

#### **Access for PRM state-of-the-art:**

The ability to travel by mass public transports plays an important role for everyone’s social insertion. It can have a direct impact on social contacts and life style quality.

Therefore, the improvement of PRM accessibility to public transport systems is a driver for reducing or even eliminating some of the daily challenges of handicapped people.

In France, on February 15<sup>th</sup> 2005, the law for « l’égalité des droits et des chances, la participation et la citoyenneté des personnes handicapées » requests PRM access to all public services, including mass public transports and railway transports.

In Europe, the “Technical Specification for Interoperability for Persons with Reduced Mobility” (PRM TSI) also determines stringent accessibility standards.

It covers the aspect of “Accessibility for Persons with Reduced Mobility” for infrastructure, rolling stock and, to a minor extent, the telemetric applications for passenger subsystems.



All those emerging standards and regulations are reflecting the sustainable change of the mindset with regard to the necessary improvements for PRM.

Despite the progress being made in recent years, door systems still need to be adapted to totally meet the requirements of the standards. The need to further develop door systems enabling PRM to board trains easily and to travel without disturbing the other passengers, still exists.

All surveys highlight the gap between the train and the platform is one of the main reasons that restrict the mobility of PRM. One crucial problem originates from the different heights of station platforms for regional and high speed trains which have no own or dedicated railway network.

The use of a typical sliding or pivoting gap filler does not solve the problem. A more complex system which is able to adjust horizontally and vertically has to be developed.

To do so, a reliable platform height detection system is necessary.

Existing solutions are based on infrared or ultrasonic sensors but those types of sensors do not provide a high degree of precision. Some additional investigations have to be undertaken to find the best compromise between cost, precision and reliability.

It is important to highlight that the market may not be ready to invest in a very complex and expensive PRM ramp system. Covering the two most frequent platform heights (550/760 mm) only may be the best compromise. The optimal balance between product functionalities and cost has to be secured.

It is also essential to elaborate on acoustic and visual passenger information systems. It is absolutely mandatory to make sure, that PRM and all other passengers are well guided to their destination.

The integration of digital displays in the door leaf was introduced in 2006 for the first time and is nowadays frequently requested by vehicle manufacturers. Its integration to the train has to be optimised in terms of relevance of the information, visibility, readability, understanding but also modularity.

The following table summarizes how this TD will improve the state-of-art and overcome today's limitations and difficulties.

State-of-the-art	New Generation DOORS
Door leaf means two skins bonded on an aluminum frame with a foam filling (one front and 1 rear pillar, 1 lower and 1 upper beam)	New composite, metallic or plastic materials and new assembly processes which are presently not widely in railway applications will be developed. The aim is to find a compromise between the highest possible performance possible, which is expensive, and the best cost ratio.  Targets to be achieved (in accordance to S2R MP and depending on market segments): <ul style="list-style-type: none"> <li>• 3 W/m<sup>2</sup>K for thermal performances</li> <li>• Increase sound reduction index by ≈ 3dB</li> <li>• Reduce the door weight by 10%.</li> </ul>
At present there is no solution for an autonomous PRM boarding. Assistance of a crew member to activate a dedicated platform is needed.	A vertical and horizontal gap filler for an unassisted and easy PRM access will be developed
Today railway solutions for PRM such as specific buzzers, specific gap fillers or specific beacons are disturbing other passengers	Non-disturbing solutions will be developed, following the demands in terms of safety and non-disturbance.
Very few visual or sound information for passengers on the door	Interaction of door and passengers displaying real time visual or sound information to better guide passengers and improve the passenger flow
Each time a new functionality such as passenger counting, displays, etc. has to be added to a door, the complete door leaf and/or DCU have to be changed.	A plug and play approach will provide a standard for device connectivity which results in: <ul style="list-style-type: none"> <li>- a simplified validation process</li> <li>- more flexibility to change the functions of the door during the life time of the train.</li> </ul>

### 1.5.6.3. Specific Demonstration activities and contribution to ITDs/SPDs

The contribution of TD 1.6 Doors to the different ITDs of Shift2Rail is shown in the following table:

Research Area	Specific Technical Objective	Specification Activities	Demonstrator		Focus of activity
			Market	TRL	
Doors & intel. access systems	PRM access and communicating door	Technologies and concepts	Regional	6/7	Development of adaptable (horizontally and vertically) gap filling solutions for two platform heights, safe platform detection technologies and a smart communicating door for PRM
	Light and comfortable doors	New materials and assemblies	Regional	6/7	Development of doors with reduced weight, improved acoustic and thermal performance

A regional train will be the most appropriate type of trains for on-track testing to validate the newly developed systems. However, other train families will be considered and results for all market segments will be assessed during the projects.

#### **1.5.6.4. Impact of the Doors and Access Systems Demonstrator**

The most significant **quantitative benefits** to be obtained by the measures described in the previous sections are:

- Reach 3W/m<sup>2</sup>K as thermal performance
- Increase door acoustic attenuation by 3dB, with priority given to high speed and regional trains on both thermal and acoustic behavior.
- Reduce threshold heights and gaps to 10 mm instead of 50 mm, as permitted today,
- Reduce the number of noise producing PRM devices by an estimated number of approximately 10% of the actual cases
- Reduce door weight by up to 10 % depending on the train family

These benefits will have direct impact to the overall KPIs given in the Shift2Rail Master Plan:

- System capacity:

An increase in the number of passengers per meter of the train length is expected by reducing the weight of doors.

An increase of the line occupancy rate can be expected after the introduction of:

- Systems enabling autonomous PRM entrance, lowering the operational time
- Light weight solutions, reducing the opening and closing time of the door, reducing the waiting time of the train **in the station and then reducing the total number of trains needed for operation.**
- Competitiveness: Lighter door systems will also reduce the maintenance cost:
  - Of the infrastructure, as lighter trains cause less wear and tear on the track.
  - In terms of cost for the fleet by reducing the number of trains

At the end of the project the following improvements will be ready for **market introduction**:

- Higher passenger comfort
- Better accessibility to trains for Persons of Reduced Mobility
- Reduction of train weight and energy consumption
- Higher reliability and availability

Track tests with technical demonstrators will guarantee that new features can be considered as proven.

It is expected that the outcome of the project will also impact TSI regulations and standards. The members of the TD doors will be involved in the appropriate standardisation and regulation groups.

The TSI and standards listed above may need upgrades which include the new concepts proposed by the project members.

This involvement in standardisation bodies improves the chances for a future market uptake of the innovations.

The following section summarises the strategic impacts of the TD Doors:

Strategic Aspect	Key Contribution of the TD
Competitiveness of the EU industry	<p><u>Technological leadership in train entrance system</u></p> <ul style="list-style-type: none"> <li>• The use of advanced material technology gives the European rail industry the opportunity to become the trendsetter for a new generation train entrance systems.</li> <li>• Modular doors result in a significant reduction of LCC and will also help to technically differentiate from competitors.</li> <li>• Innovation will become the key competitive edge for the European rail industry. This would allow to shift the actual mainly cost related competition with Asian suppliers to a technology based .</li> </ul> <p><u>Tangible benefits for the end user:</u></p> <ul style="list-style-type: none"> <li>• Convey the feeling and confidence of high level of comfort for passengers</li> <li>• Support the capacity increase through lighter train entrance solutions</li> <li>• Fulfill PRM specific needs in terms of mobility and passenger flow</li> <li>• Combine visual and audible information considering sensory disabilities</li> </ul>
Compliance with the overall EU objectives	<p><u>Capacity increase:</u></p> <ul style="list-style-type: none"> <li>• Lighter door solutions will provide: <ul style="list-style-type: none"> <li>○ Increase in capacity</li> <li>○ Improve the competitiveness =&gt; more passengers for the same cost</li> </ul> </li> </ul> <p><u>Greening of transport:</u></p> <ul style="list-style-type: none"> <li>• Energy savings can be achieved through lighter materials and an improved performance of the entire door system</li> </ul>
Degree of maturity of the envisaged solutions	<p>Currently most of the proposed technologies have a TRL 1 or 2, which means the features have been observed in principle and the possibilities of using them are formulated.</p> <p>The target of the TD Doors is to transfer successful concepts up to a TRL 6 or 7: Demonstration of prototypes in a relevant environment, respectively system prototype demonstration in an operational environment.</p>



### 1.5.6.5. Implementation of the work programme

#### Methodology for the implementation of the work programme:

A clear methodology has been devised for the organisation of the technical work in the project, in order to maximize the probability that the desired final objectives are met. This is shown in Figure 35.

**Figure 35: Methodology for TD Doors**

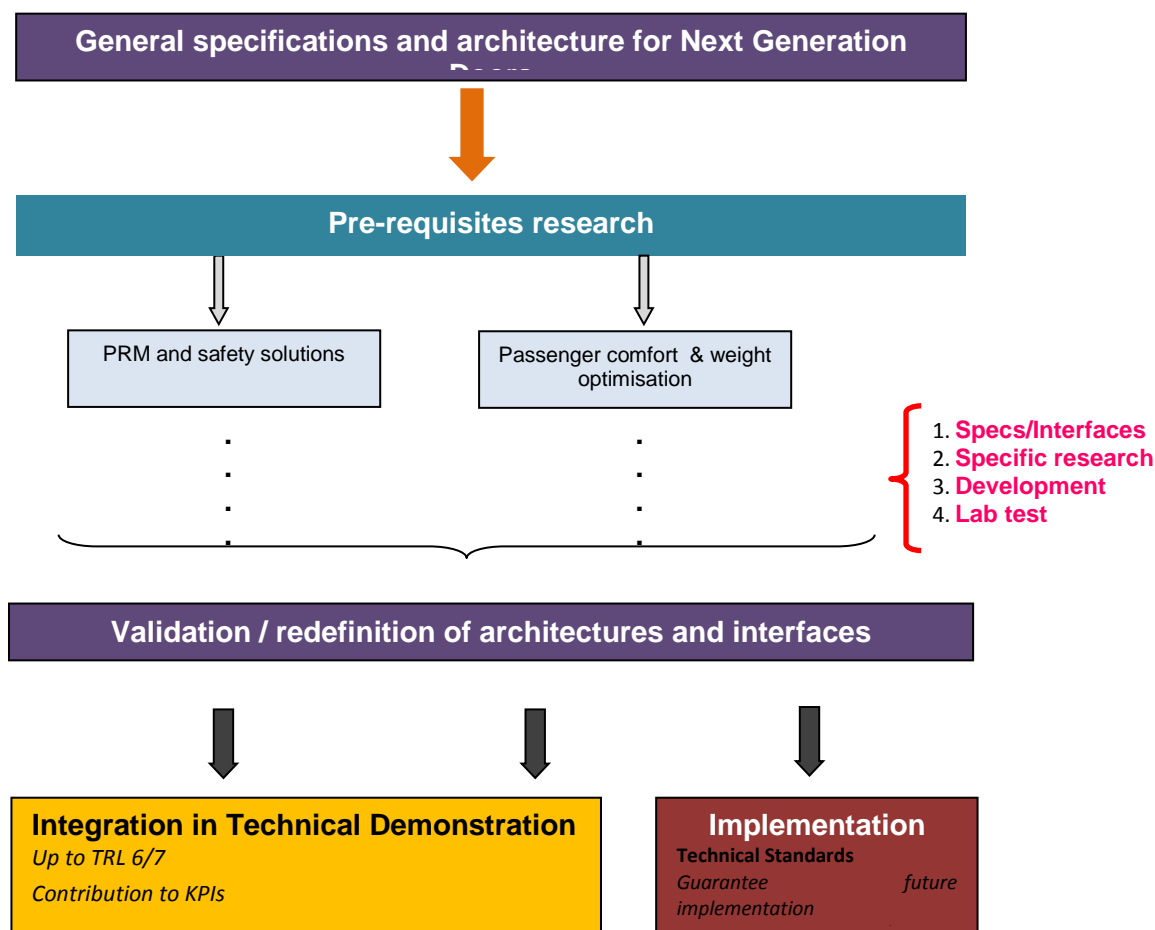

In order to achieve the final objectives of this work and to ensure market uptake, it is necessary to involve the following stakeholders throughout the project:

- Suppliers of doors and entrance systems, who will be the core developers of the technology
- Railway car manufacturers, who are dealing with the integration of the door in the train and its interaction with other systems
- Railway operators, who will bring their experience in term of operation and passengers' experience.

The collaboration with small and medium size Enterprises (SME), universities and research institutes specialized in key technologies is also a key success factor. The research community is expected to provide technological capabilities and know-how in some of the selected candidate technologies.



### **T1.6.1 – Technical development prerequisites**

The objective of this task will be to work out the general specifications for the next generation of doors, and also to carry out basic preliminary research on new materials, potentially useful technologies and design concepts to be employed later in the following tasks.

- Starting with a global study of available potential materials, the target is to investigate which materials match best with the objectives of the TD (up to TRL 3)
- Innovative acoustic / thermal material and architectures will also be investigated (up to *TRL 3*).

For each project, the specification will include modularity and installation time requirements.

A variety of members will collaborate in this task to define the general door access use case as well as the functional, performance related and RAMS and safety requirements.

Members will:

- provide the necessary information needed to support the system development work with regard to the integration of the door system.
- participate in the preparation of specifications,
- coordinate other TD members involved in the definition of the specification
- supervise the laboratories and universities taking part in the development
- coordinate the general specification writing and federate the different TD members including management of intellectual property rights (IPR)

Members with experience in the aeronautic industry and specific know-how in composite materials and technologies will perform the following tasks:

- Contribution to the specification phase
- Participation in the preliminary research on composite materials and technologies
- Material selection and properties screening
- Trade off analysis of the different solutions proposed
- Active participation in the design and calculation of the door structure
- Support the other members to create final reports

Open calls are foreseen:

- For literature search
- For material characterisation and comparison, taking into account cost analysis
- For specific testing



- For specific material development (with additive for instance).

#### **T1.6.2 – PRM, Safety and Door Entry Surveillance solutions**

The objective of this task will be the development of PRM, safety and door entry surveillance solutions including:

- Development of an adaptable gap filler system for one and for two platform heights, platform detection technologies, noiseless solutions and use of new sensors (up to TRL 6/7)
- Alternatives on noise attenuation (up to TRL 3)

Members will collaborate in this task to define the detailed specification of the autonomous access system for PRM. Members will:

- Share knowledge on R&D activities covering the use of new materials and technologies
- Review safety critical aspects
- Review pertinence of sensor detection solutions from operation and maintenance perspectives
- Elaborate functional requirements including passenger expectations. Establish links with the infrastructure experts for information concerning platform data across their entire railway network
- Share possible solutions and areas where most benefits are to be gained based on their experience
- Interface with PRM associations to test solutions
- Participate in passenger test activities, share experience from past passenger surveys
- Use the virtual reality room to simulate most promising solutions to obtain their look and feel, to test degraded operational conditions and several technical choices (e.g. the positioning of passenger information on door leafs)
- Review test plans and participate in mock-up tests in degraded operational conditions.
- Provide a technical manager with knowledge of PRM TSI
- Provide electronic system engineers to perform research on platform detection technologies and solutions for adaptive steps and ramps.
- Design, develop, manufacture, validate and integrate a prototype version that is compliant with the specification requirements but also the complete access system (door and step) in order to be able to integrate it on train.
- Develop a test platform to simulate the different platform heights and shapes
- Validate the complete access system using existing own test facilities to perform laboratory tests

- Manage the interface and support from a laboratory specialized in public transport ergonomic for handicapped persons.

Open calls are foreseen for:

- The support of a laboratory specialized in public transport ergonomics for PRM
- Expertise in platform detection technologies

It is also important to highlight that synergies can be found with IP3, TD3.11 **“Future stations”**.

These TDs deliver information on the type and height of future platforms **which are** needed to design the new gap filler systems.

### **T1.6.3 – Passenger’s Comfort, Weight and Energy Consumption Optimisation**

The objective of this task will be the development of an access door solution (*up to TRL 6/7*):

- Allowing a significant passenger comfort improvement (acoustic and thermal performances)
- With reduced weight by introducing new concepts, new architectures and new materials.

Members will:

- provide the information needed by the door system developers from a car manufacturer’s point of view.
- Review initial assumptions made on overall architecture and simulate different solutions with acoustic and thermal in-house tools to check relevance of the expected benefits.
- Provide functional requirements and define performance targets
- Share experience on acoustic activities already undertaken
- Share experience on test characterisation performed on new material
- Review the approach to and possible candidate plug and play technological solutions
- Provide expertise in fire retardant requirements of new materials
- Provide global railway system approach to evaluate the solutions proposed by the TD partners
- Use of virtual reality room to simulate most promising solutions
- Review test plan and participation to mock-up tests
- Provide technical manager with high experience in innovative materials and technical solutions (plastic, composite, metallic materials and manufacturing processes)
- Provide dedicated experts for door panel design and validation
- Perform the complete door design (3D model) and interface definition (operator, leaves, coordinating bars)



- Perform finite element analysis (FEA) calculation for the complete access system:
  - mechanism
  - leaves
  - coordinating bars
  - fittings
  - hanging

The calculation will be done for all load cases such as static loads according EN standards and UIC leaflet, pressure waves, fatigue determination.

- Develop and manufacture the complete access system
- Validate the mock-up of the complete door system by undergoing laboratory tests of leaves, operators, door control units meeting the challenging specification requirements.

Composite material experts will:

- Participate in the research on passenger comfort, acoustic and thermal performance
- Basic design of the door structure using composite materials.  
An analysis will be done to compare the new materials with state of the art.
- Perform material characterisation and testing
- Undertake manufacturing concepts studies (materials/processes/tools)
- Do preliminary design and detail design drawings for composite doors structure
- Manufacture representative scale prototypes to support chosen structural concepts.
- Perform prototyping testing
- Perform a recycling assessment and deliver an analysis of the possibilities to reuse materials at the end of the product life time.

Open calls are foreseen for:

- Research on lower noise solutions (active noise)
- For material and part characterisation and comparison, taking into account cost analysis
- For specific testing
- For innovative manufacturing tool solutions for the designed composite parts if needed



Synergies with other IPs:

- IP1, TD 1.3, Carbody Shell, which will also investigate solutions for composite materials. The specific requirements there will not be completely equivalent with doors, but synergies on the basics may still be possible
- The respective results of the TD Doors will be feed into the CCA Noise & vibration where they will be evaluated further on an integrated system level.

#### **T1.6.4– Integration in Technical Demonstrator, demonstration and assessment:**

The objective of this task is:

- To test the new access systems in the relevant environmental conditions developed up to TRL 6/7.
- Collecting performance data assessing the next generation of doors, including technical and economic aspects. The KPIs to be investigated are in line with the KPIs of the entire IP1.

Members will:

- Provide information needed from a car manufacturer's point of view and will support the door system manufacturers with regard to the interfaces to other subsystems of a vehicle. Provide consists and manage the organisation of the test activities
- Install new door systems on the test vehicle for both initial trials and the following tests to be undertaken in a commercial service environment
- Support the preparation of the necessary certification reports
- Specify the modifications needed to integrate the newly developed access systems in a real environment
- Perform the integration
- Remove the test equipment from the vehicle
- Measure and report the test performances achieved
- Undertake an in-depth analysis in order to compare the test results with the state of art and highlight the improvements
- Feed the improvements to the integrated assessment tool of the S2R project.



### 1.5.6.6. Planning and budget:

TASKS	TRL	2016	2017	2018	2019	2020	2021
<b>TD 1.6 DOORS</b>							
1.6.1 - Technical Development Prerequisites	Up to TRL 3	[Bar spanning 2016 to 2021]					
1.6.2 - People with reduced mobility (PRM), safety & Door Entry Surveillance solutions	Up to TRL 5/6	[Bar spanning 2016 to 2020]					
1.6.3 - Improved passengers comfort and weight & energy optimisation	Up to TRL 5/6	[Bar spanning 2016 to 2021]					
1.6.4 - Integration in technical demonstrator, Demonstration & Assessment	Up to TRL 6/7					[Bar spanning 2020 to 2021]	

The estimated total budget for Doors TD is around 9,8M€.

### 1.5.7. TD1.7: Train Modularity In Use (TMIU)

#### 1.5.7.1. Concept and objectives of the Demonstrator

The TD TMIU covers activities beyond those being undertaken in the Roll2Rail Project. It focuses on the passenger saloon and has 3 objectives: offers passengers an environment which improves their satisfaction, increases the passenger capacity and improves the flow of passengers between the platform and the train to reduce dwell time. The activities will consider the modularity and flexibility of the passenger lounge areas with the use of standardized features and plug-and-play components in order to simplify maintenance and refurbishment operations. This innovative work will propose economic solutions handling conflicting requirements such as passenger capacity, comfort, weight and available volumes to be made to create train configurations meeting passenger demands that are evolving during time.

Studies and business intelligence on the subject highlight quite different definitions in the meaning of “modularity”.

Generally, the concept of modularity can be separated into 3 categories with a different purpose for each of them:

- The MID (Modularity In Design): the train is made of small independent modules connected between them to constitute the finished product.
- The MIP (Modularity In Production) which primarily relates to the manufacturing process to facilitate the implementation of equipment (comfort and/or services)
- The MIU (Modularity In Uses) which particularly relates to the facility of use, handling or product evolution

The overall objective of the TMIU TD is to make railway transport more attractive to passengers.

The interior design of current Rolling Stock is not adapted to the demand of flexibility to meet the passenger demand during the in-service operating life of a train (40 years): it is not possible to easily change the interior layout or add services (wall outlet, etc.). When initiating the process for a new train procurement, a railway operator has to make a final choice on the design 6 to 7 years before



the first train enters service. There is a risk that the solution becomes quickly obsolete and does not meet the passenger expectations. This TD will mainly work on MIU.

Concepts based on MIU principles could lead to the possibility of evolving interior configuration, such as offering more comfort to families during weekends by moving seats or easy to change layouts within a coach. Innovative MIU concepts could facilitate passengers flow to get in or out of the train or between vestibule and saloon by, for example, increasing space allocated to the vestibule or by adapting the passengers areas.

MIU concepts could lead to zone differentiation areas within the same coach, for example by adding glass partition or interior doors (transforming an open space into several individual quiet spaces for example).

MIU concepts must allow coaches to be refurbished quicker than with current coach design and, of course, at an affordable cost that will permit more often “up-to-date” configuration meeting passengers requirements.

As stated above a Railway Operator has to freeze the interior design of a new train 6-7 years before the first train enters service. The final train of the order can be delivered 5-6 years after the first one. So 10 years can elapse between the design phase and the delivery of the final train. In ten years, the passenger needs evolve. In one hand we have to decide the comfort at the beginning of the project with any flexibility few years after (air conditioning is designed and validated by test for a specific diagram in example). In the other hand a refurbishment is an expensive operation and most of budgets are being reduced

Concepts based on the **Modularity In Uses approach can lead to genuine innovative solutions fitting the market needs and able to modify the configuration of coach interior at an affordable cost.**

Today it's more difficult to anticipate the number of passengers and their flow inside the train than few years ago. It is clear that passenger expectations in terms of interior design will be different from today depending on the purpose of the travel (business or leisure travel, alone or with family) and the travel period (during the week or the weekend for example).

Passenger needs evolve quite rapidly (typically XX years) and a configuration can quickly become outdated with no possibility to modify if it has been be designed without including modularity concepts.

Change more often interiors design can be a way to increase reliability: Today an interior design is used during 20 years or more, it easier guarantee reliability if you design the equipment for only less than 10 years. The return on investment will guide to select concepts.

The TMIU TD will cover the market of new trains and refurbishment. The aim is to go up to TRL 5-6 with TRL 4 disruptive concepts. The objective is to have a blend of physical and virtual mock-ups of the disruptive concepts.

The TMIU TD will complement the Roll2Rail activities addressing comfort at the global level (passenger and operating points of view) and working out solutions. Benefits are evident regarding the increase the use of railway system.



**Technological output to be delivered by this TD:**

New generation of Rolling Stock incorporating flexible and adaptative interior configuration to adapt quickly and in a cost efficient way to meet the evolving demand during the in-service operating life time of the train.

**Specific achievements to be delivered by this TD:**

The TMIU TD will work on the design of train interiors meeting passengers and operator's needs.

Operators need to keep ahead and to be able to deal with the passenger's needs: mobility evolutions require new necessary adaptations of trains.

If interiors are easily modifiable, railway undertaking could offer a just in time evolution of its trains to accommodate specific seasonal travel needs (e.g. skis or additional luggage).

1. *Adapt the train interiors to increase **capacity***
2. *Reduce dwell time at stations by improving **passenger flow** in and out of train and between vestibule and saloon*
3. *Increase **passenger comfort** and satisfaction*

The following table shows how the proposed activity will contribute to the achievement of the Shift2Rail objectives as stated in the Shift2Rail Master Plan:

**Table 9: Objectives and deliverables of the TD**

S2R Objectives	TD Objectives	Practical contribution (how)
Improved services and customer quality	<ul style="list-style-type: none"> <li>• the operational reliability of rail:               <ul style="list-style-type: none"> <li>○ increase the reliability by the facility of equipment change related to the travellers</li> </ul> </li> <li>• the capacity of rail:               <ul style="list-style-type: none"> <li>○ increase capacity « on demand » to adapt the train to the need</li> </ul> </li> <li>• an improved customer experience:               <ul style="list-style-type: none"> <li>○ offer the possibility to add easily new services or new spaces</li> </ul> </li> </ul>	<p>Creating interiors for 15 years, interiors can be developed for 5 or 6 years.</p> <p>Modularity and plug and play solutions will allow quickly answering to punctual default and increasing the global reliability.</p> <p>A modular interiors design will facilitate the upgrade the passenger experience.</p> <p>New materials with better performance (weight, acoustic, thermal, etc.) can be studied and a fit-for-purpose innovation approach can be used</p>
Reduced system costs	<ul style="list-style-type: none"> <li>• Lower investments costs</li> <li>• Reduced operating costs</li> </ul>	<p>Modular more possibility of use and help to reduce the ROI rather than a non-modular rolling stock.</p> <p>New technologies and eco-design can help to simplify the equipment. Plug and play also permits standardisation and less expensive devices.</p> <p>Modularity permits to adapt trains to passenger or operation needs to optimise operating costs.</p> <p>A modular train will clearly simplify refurbishment operations</p>
Simplified business processes	<p>Improved standardisation</p> <p>Simplified authorisation</p>	<p>There is presently no standardised railway fixations systems (electronic or mechanical). TD will seek to create the basis of a new European standard for fixations.</p> <ul style="list-style-type: none"> <li>• A new standard of system's fixation will simplify authorisation; for example for crash resistance, new calculations of seat fixations will be reduced.</li> <li>• Standardisation of interfaces of customer-related equipment, e. g. HVAC, also will support to simplify business process, adaption to new demands and refurbishment.</li> </ul>

S2R Objectives	TD Objectives	Practical contribution (how)
Enhanced interoperability	<ul style="list-style-type: none"> <li>Respect and adaptation of TSIs</li> </ul>	<p>To valid new concepts TD proposes to use more systematically the Virtual Reality tools during the design stages (visual information, layout, modularity, etc.).</p> <p>Other specific tools will be used: flow simulation, thermal and acoustic performance simulation, etc.</p>

### **1.5.7.2. Technical ambition of the Interiors modular systems Demonstrator**

The question of interior modularity is mainly a question of needs for the operators to be in accordance with passengers' needs. Each railway company operates on its own network which has intrinsic characteristics (number and length of lines, types of passengers, flows of travellers) and express a real interest about the modularity from their railway exploitation (park to make evolve, diversity of the lines with average lines and long distances, diversity of rolling stocks).

But the concept of modularity is multiple and is potentially a source of complexity of rolling stock. It appears necessary to the owners to define well the modularities they need.

The first stage of the TMIU TD will thus identify and agree on the common needs between railway operators in order to define the most relevant market potential in the short term, but also “the ideal” in order to have also a medium-term reflection and to identify disruptive innovations.

Short term could be for example to adapt existing technologies used in other industrial sectors (aeronautic, camping car, buses): add an interior door, move a panel, hide a table or a seat. In this way, the innovative contribution is the new uses offered for railway transportation.

Disruptive innovations could be for example to adapt a vestibule to the passengers flow during the day, to hide a table/seat or to change the interiors ambiances “on demand”. Task1 will follow an open innovation approach to allow the members to think outside the box.

The innovative solutions could be new uses, new kind of refurbishment or new technologies.

Although there is a general agreement within the industry that there are no major technical difficulties to design a modular train, the products are often presented like modular because constituted by easily interchangeable modules. However this interchangeability is really effective only in phase of design and production. There is only little flexibility of evolution for and by the operator.

Thus by the “modular” term, the manufacturers often announce a MID (Modularity In Design) or a MIP (Modularity In Production) whereas the operators seek to evolve to a MIU (Modularity In Uses).

A better Modularity In Use does also mean easier maintenance and refurbishment due to standardisation.

The example of AGC train is interesting because electrical equipment and mechanics intended for the travellers are mainly assembled on rails including lighting. This design seems to offer a great modularity from its design. Unfortunately, the principle is usable only in MID and MIP. The

modularity offered thus made it possible to reduce the manufacturing and assembly costs, to propose various options during the ordering, but did not have utility during the life of rolling stock to reduce the costs at the refurbishment time or of diagrams evolution.

**Figure 36: Example of AGC (France)**



Railway industry enormously evolved to the modular concept to make it possible to reduce manufacturing time while offering more options or of personalisation to the order, but offers only little MIU.

The fact is that the MIU is not yet a mature subject in the railway environment neither in the manufacturers, nor even in the operators still little accustomed to correctly specifying these needs and well controlling their impacts (costs, technical complexity,...).

The other types of transport develop also the concept of MIU, their market (particular vs public) or their regulations facilitate the application of modular installations. Some examples can be found in the following figures.

**Figure 37: Example of moving table in a camping car**



**Figure 38: Airplane "Quick change" system**



**Figure 39: Example of modular settees in yacht**



**Figure 40: Example of wheelchair users' space in bus coach**



**Shift2Rail Vision of the new generation of Train Interiors:**

The objective is to make train more attractive.

TD proposes to explore fixation and plug and play systems to:

- be able to reconfigure the passengers area inside a coach:

- Capacity or passengers' area – few times per year: depending on the passenger capacity requirements or their passenger profile (e.g. commuter train for workers) or destination (e.g. ski trains).
- Capacity – Every 5-6 years: on refurbishment (new design, new interior layout, etc.)
- Interiors atmosphere – few times per year: depending of the seasons or the line travel (lighting, decors)
- Interiors atmosphere – Every 5-6 years: on refurbishment (new complete design)
- be able to reconfigure passenger information support inside a coach:
  - few times per year: depending on the passenger capacity requirements or their profile (adapt to the seat position or capacity)
  - Every 5-6 years: on refurbishment (new design, easily updated, new connectivity, etc.)
- to be able to keep a comfortable indoor climatic conditions (thermal comfort) whatever the interior layout:
  - minor evolutions: move interiors partition walls, increase capacity or change the positions of the seat
  - major developments: new design of the roof, new luggage rack location in height or new closed spaces added

The modularity must allow the train being more competitive, but also attractive for the travelers. Consequently, work of Roll2Rail will be a guide for the TD:

- Definition of a standard way: a base for the reflections of need for short-term capacity evolution (“upon request”)
- Definition of the concept of comfort and attractiveness: a base to select the ideas
- Use Methodology proposed in R2R WP6 to measure comfort and the attractiveness: a base to carry out the concepts

The objective of this TD is thus to reduce the ownership costs of rolling stocks while remaining with a comfort level and attractiveness appreciated by the travelers. The modularity in the method will be used to address these 2 requirements for interior installations.

The following table summarizes how this TD will progress the state-of-art and overcome today's limitations and difficulties.

State-of-the-art	New Generation INTERIORS
Roll2Rail INTERIORS: improved methodologies to qualify comfort	Evolve interiors Design without degraded comfort or attractiveness for passengers. Roll2Rail will give to the TD the limit to stay and key to select ideas/concepts.
MODTRAIN – EUPAX / PrEN Design for PRM use: work on Interiors Design (Toilet, services, PRM requirements, ...) but no result on Modularity In Use	These 2 European Projects (research and standard) have defined the needs of PRM. The TD will work on solutions to offer flexibility for railway operator to increase PRM accessibility (add quickly PRM seats or wheelchair user spaces for example) and it will give to the working group the available limits of design to select ideas/concepts
A complex industrial operation is necessary to change diagram during the in-service operating life	Research modularity: To increase capacity by 15% to 25% in a same train To reduce the cost of layout change by 50% To reduce the time of layout change by 50%
A limited evolution of the mechanic attachment units and electric connections	To set up a plug and play approach (mechanical and electric connections): To offer the possibility to change interiors design without the use of important external equipment To reduce cost operation (refurbishment) by 25% To simplify the validation process (standard)
No clear definition of “modularity”: for who, for which benefits, ...	Library and semantic search: To define common terminology in Europe To facilitate the understanding of target between an operator and a manufacturer
No standard of fixation (vs aeronautic with “Quick change” system)	Propose common standard of fixation system
EUROPEC “Flexible Rolling Stock”: no enough experience to edit an European guide	Recommend new European standard by studies and mock up

The TRL objective of the TD Train MIU is a TRL 5-6.



### 1.5.7.3. Specific Demonstration activities and contribution to ITDs/SPDs

The following table summarises the contribution of TD 1.7 MIU:

Research Area	Specific Techn. objective	Specification Activities	Demonstrator		Focus of activity
			Market	TRL	
Modular Interiors	Capacity	Seats, table and passengers services	Minor maintenance (TD's target: MIU < 1 day)	4	Quick change and secure fixation system: change the position of the seats, hide tables or seats, translate panels, move electric plug, <ul style="list-style-type: none"> <li>Study the possibilities to increase capacity in an existing train with existing equipment by transport operator's staff</li> </ul>
			Refurbishment (TD's target: MIU < 2 weeks)	6	Modify interior design <u>without in-depth engineering studies or laboratory test</u> : add new seats, add electric plug, add handles, add screens,... <ul style="list-style-type: none"> <li>Study the possibilities to increase capacity in existing train with new equipment</li> </ul>
	Passengers flow	Vestibule, doors, passageway	Minor maintenance (TD's target: MIU < 1 day)	5	Evolve size of passageway by the operator's staff: increase vestibule, improve the design of the interior layout using passenger flow analysis,... <ul style="list-style-type: none"> <li>Study the possibilities to increase passenger flow in an existing train with existing equipment</li> </ul>
			Refurbishment (TD's target: MIU < 2 weeks)	4	Evolve all interiors design and access <u>without in-depth engineering studies or laboratory test</u> : add new access doors, new circulation on board the train <ul style="list-style-type: none"> <li>Study the possibilities to increase fluidity in existing train with new diagram</li> </ul>



Research Area	Specific Techn. objective	Specification Activities	Demonstrator		Focus of activity
			Market	TRL	
	Comfort/Attractiveness	Decors, Lighting, Information devices (screen, ...) and Thermal comfort	Minor maintenance (TD's target: MIU < 1 day)	6	<p>Evolve the comfort: move the position of the thermal sensor or add a thermal sensor for better regulation, move screen information, move electric plugs, change decors or lighting in few areas.</p> <p>Offer that bit more differentiated areas easily: add separated panel, add interiors door for more thermal and acoustic comfort,...</p> <ul style="list-style-type: none"> <li>Study the possibilities to adapt comfort to new diagram in an existing train with existing equipment by transport operator's staff</li> </ul>
			(TD's target: MIU < 2 weeks)	5	<p>Evolve all interiors design <u>without in-depth engineering studies or laboratory test</u>: add new decors in all areas, increase size of toilets, adapt air conditioning to a new diagram without test in climatic chamber.</p> <ul style="list-style-type: none"> <li>Study the possibilities to increase comfort and/or attractiveness in existing train</li> </ul>

#### 1.5.7.4. Impact of the Train MIU Demonstrator

The Modular Interiors Demonstrator will attest the possibilities of modularity by the use of plug and play/ modular systems which provide more operational flexibility and reduce maintenance costs by reduced intervention times and use of standard components, to reach operating costs reduced.

These impacts are not limited to particular market segment(s) (high speed, regional or urban), but the Modular Interiors Demonstrator will give priority to a train demonstrator compliant with its operating and maintenance strategy.

The improvement resulting from the content of this RIA aims to contribute to the achievement of the KPIs of the Shift2Rail initiative according to the following benefits:

- To increase easily and at low costs capacity of an existing train by 20% (Regional or Intercity train in main target)
- To increase passenger flow in and off trains to reduce by 15-20% dwell time in stations (Regional and Intercity train in main target)

- To divide by two the time between large interiors retrofit operations carry out twice more during the life of rolling stock at the same LCC
- To ensure that thermal comfort meets customer's demands and not only standards, especially when rebuilding a vehicle or changing shifting vehicle's use, e.gg from long distance to regional traffic

All the principal elements required for rapid market uptake after Shift2Rail have been taken into account. These are:

- Identification by two railway operators of the most common useful Modularity needs. That will give the short-term priorities.
- Search for already operative techniques in other fields more advanced on modular installations
- Search existing solutions (MID, MIP, ...) from railway manufacturers which could easily become MIU with few adaptations
- Propose types of layout that combine interiors flexibility, passenger comfort (specially thermal impact) at an acceptable cost
- Demonstration of technologies in an operational environment to test solutions with passengers and demonstrate the benefits

The following table summarizes the strategic impacts produced by the TD results. This is organised along three main aspects: the support to the competitiveness of the EU industry, the compliance with the EU strategic objectives, and the degree of maturity of the solutions envisaged to be realised and to be put into practice in the railway sector.

Strategic Aspect	Key Contribution from the TD
<i>Support the competitiveness of the EU industry</i>	<ul style="list-style-type: none"> <li>• An operator selects interior design. Choices vary from one country to another and are also depending of the a type of exploitation.</li> <li>• Tangible benefits for the end user:               <ul style="list-style-type: none"> <li>○ Increase the possibility to fit to the needs the passenger lounge area</li> <li>○ Reduce the cost of refurbishment</li> <li>○ Increase capacity for new as well as existing train</li> </ul> </li> </ul>
<i>Compliance with EU objectives</i>	<ul style="list-style-type: none"> <li>• Increase capacity: you can evolve the capacity of each coach</li> <li>• Increase attractiveness: coach interior and services on board can be adapted more quickly to evolving passenger requests and more economically than currently</li> <li>• Greening of transport can be achieved by optimisation of capacity</li> </ul>
<i>Degree of maturity of the envisaged solutions</i>	<ul style="list-style-type: none"> <li>• From TRL 3-4 (for new ideas) to TRL 5-6</li> <li>• The first part of the work will explore available existing solutions, so a limited number of concepts will go to higher TRL (TRL 5-6) to finish in TRL 7-8</li> </ul>

### 1.5.7.5. Implementation of the work programme

The TD is separated into 4 tasks, as represented in figure 41.

**Figure 41: Methodology for TD Train Interiors**

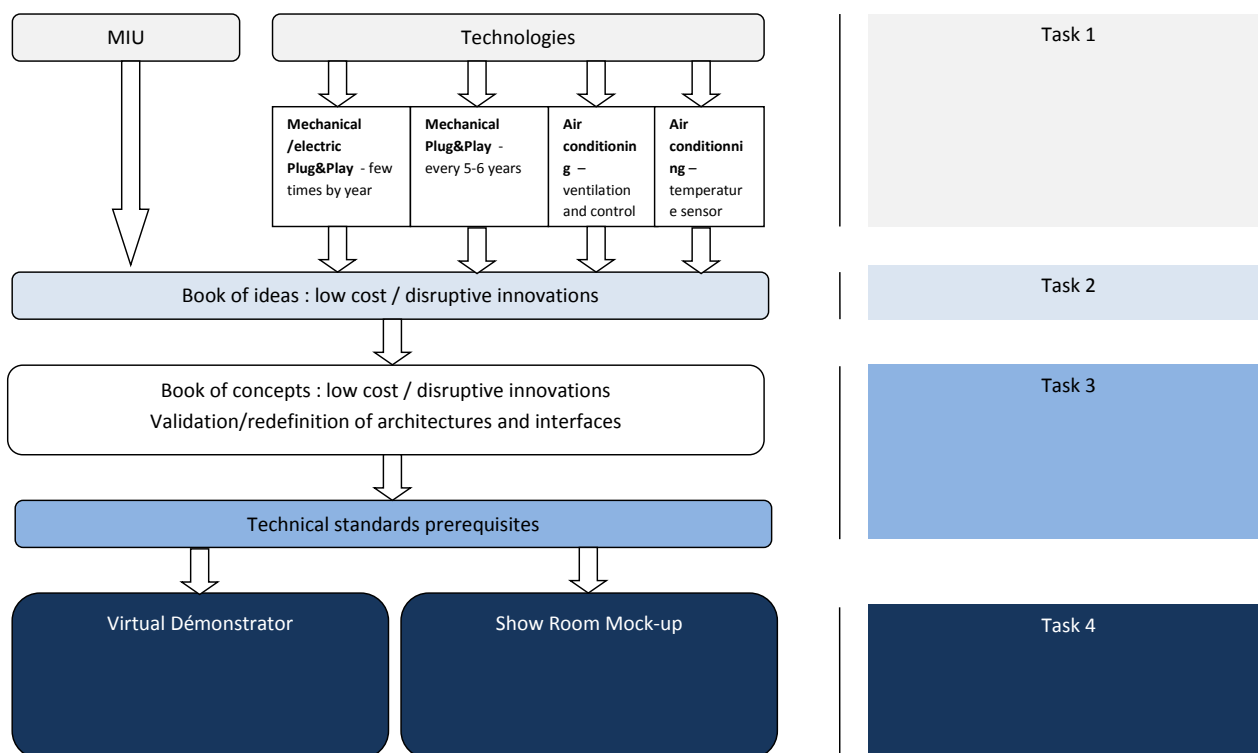

A first task will consist on realise a state of art of technical possibilities for a modular design interior (railway, aircraft interiors, ...): seats, tables, interiors ambiances, screens, ....

In parallel the operators will define their needs of modularity. The objective is to identify priorities and guide the follow-up studies. The different needs will be assessed.

A first work will be to realise a **Book of ideas**. This phase will be very aware without constraints of feasibilities. The aim is to propose new uses in two ways: simple applications and disruptive ideas.

The book of ideas will be the basis for the following phase of feasibility studies. Different constraints (mass, vandalism-proofed, European railway standards, LCC and facility of use) will guide for the selection of the most relevant ideas.

This **Book of concepts** will be like the book of ideas in two parts: low cost short term solutions and disruptive longer term solutions.

Among these concepts, the working group will select the most mature and the most relevant concept for the demonstrators.

A the end, the selected concepts become **technical solutions** will be valid by simulation and Virtual Reality or scale mock-up for mechanical equipment is proposed to put in situation these concepts and to test them in a railway environment near to reality.



Two types of demonstrators are envisaged: physical mock up and digital demonstration using Virtual Reality tools. The advantage of the digital demonstrator is that it can be configured easily to explore a large range of different design.

In the final step, the solutions will be validated from a technical and economical point of view.

### **Description of tasks**

In order to achieve the final objectives of this work and to ensure market uptake, collaboration between vehicle manufacturers and operators is necessary. Participation of partners bringing the expertise from other industrial sectors is also necessary.

The collaboration with small and medium size Enterprises (SME), universities and research institutes specialized in key technologies/domains is also a key success factor.

#### **T1.7.1 – Needs and state of art**

The objective of this task is to agree a common definition of “modularity” for passengers and for operators and review current implemented solutions: To clarify the concept of modularity, which is multiple, and to identify the types of modularity (scale of time to carry out this modularity, which carries out the modularity) – thus to define the various needs for modularity and to agree the associated terms so that there is common understanding.

*Members will collaborate to realising a list of the type of modularity with a clear and shared definition.*

They will classify the types of modularities by relevance in term of needs or immediate interest. This will make it possible to the project team to determine the benefit future short-terms and to focus the resources on these points.

Members will collaborate to give the operator point of view with a matrix of choice with level of priority.

Search for quick fixation systems on the market and analyse relevance compared to the needs previously identified. Research is extended to all relevant industries.

Research existing of modularity solution for services or comfort (lighting, socket, etc...).

The state of the art will search possibilities to modular heavy equipment as light, mechanical as electrical components. The principle of having a general sight of possible (is what can easily move of the screens for example). The members will also work on the possibilities of "smart windows": modular optical and/or thermal properties of the window (less energy consumption in summer, personalisation by the passengers, ...)

Members will produce a report of various attachment units rapid (clips or mobile) with their constraints (mass, required effort, robustness, ...).

Share the influence of interiors layout modifications on passengers' thermal comfort. Design of passenger area and air conditioning are linked directly. Operators collaborate to give their own experiences to identify the lacks and the constraints.

*Activities allocated to Open Calls: No Open Calls are expected within this task.*

### **T1.7.2 – Potentials and forces (Ideas)**

The objective of this task is to provide overview of the needs and to identify the different possibilities on MIU.

#### **Feasibility study on the potential increase of capacity**

Work on the layout of existing rolling stock to identify the possible improvements in theoretical capacity without considering the disadvantages (ie increase in weight). The objective is to quantify the potential and to start to specify the request. One could imagine two level standards: a level which seems “easy” on paper beyond the technical solutions to be found, but which one imagines well the first solutions and a disruptive level which would be “the ideal”, but one does not see yet too much how to carry it out.

The main segment of market would be Régional and Intercity trains because these types of train need to transport passengers with very different desires which can be opposite for the same train (peaks of attendance during the morning, difference needs between weeks and week-end, ...)

**Feasibility study on passengers flow and ergonomic impacts.** To change a diagram implies to change space on board it is thus necessary to study the consequences of a fast change of diagram. That also relates to travellers information and on board services (maybe if there is an increase in passenger capacity screens will need to be added or readjusted to be compliant with PRM TSI)

Operators specify their capacity need and constraint to guide the technological choices and define few vehicle layout to compare.

**The passengers flow impacts will be simulated** with several types of layout defined by operators.

**Feasibility study on passenger thermal comfort impacts.** To change a diagram implies to change interiors design, and to maintain passenger comfort it is necessary to identify the effects on the air conditioning system. A new roof or new interior wall can degrade the thermal comfort, the pre-study will allow to identify the impact of the modularity of spaces and to guide the next concepts.

Members will specify different kind of layout to **simulate thermal passenger comfort**.

Members will specify a common document to launch an open call for ideas. The result will be a **Book of ideas** with several cases of studies (Sketch, 3D without decorations, etc...). This book of ideas will make it possible to select the concepts and to launch the technical studies.

There will be two main targets:

- Easy solutions to implant with a low cost and short-term finality
- Innovative and disruptive solutions but with a great potential with a mid-term objective

In this two main targets, we can already propose two ways: a modularity carried out several times in the year or a modularity directed towards deep refurbishment every 5-6 years (instead of 8-10 years currently because of cost).

Activities allocated to Open Calls: Open Calls could be used to realise a Book of Ideas.

### **T1.7.3 – Development (Concepts and Mock up)**

All members collaborate in this task with the objective to propose concepts and valid industrial potential solutions.

**The R2R results will help the members of TD7 to select ideas** with the objective to offer more flexibility and capacity but without degrading passenger comfort.

Members will propose concepts: selection of the promising ideas of the book of ideas and work of the solutions. Virtual Reality will be used to test the ideas (« white mock up » without final design at this step of the project).

A synthesis will be carried out in a Book of Concepts.

**The selected concepts are the compromise between technical possibilities to change quickly the passengers area, passengers flow impacts, thermal comfort passengers impact and the final cost for operators.**

Members will provide:

- studies of mechanical handling
- studies of capacity with numerical simulation of passengers flow for each concept
- studies of thermal comfort with numerical simulation for each concept

The members will deliver Digital models. The working could propose simple prototype when is necessary to pre-valid solution.

At the end of this task, all members allocate a score for each proposal (with indicators: technical difficulties, cost levels and market potentialities).

The best solutions will be more precisely studied to TRL 6.

Activities allocated to Open Calls: Innovative plug and play electric connector/ Innovative temperature sensor /Simulations and research on air flow, temperature allocation and draft depending on interior arrangement and used materials.

### **T1.7.4 – Demonstrators (tests)**

This task aims at showing the adopted solutions in two manners: a show room mock-up with industrial prototypes and a digital realistic demonstrator in Virtual Reality.

**The final TRL of the TD is TRL 5-6.**

This task needs to identify if the best way is to have “real” mock-up of train interior area (rolling stock gauge,...) or to have a show room space with many independent solutions. In these two ways, Virtual Reality demonstrator can be used in the first case to show other applications and in the second case to show the solutions in a realistic environment.

Members will prepare together the organisation and the provision of the equipment in the scale 1 mock-up and in the digital mock up.

The members will prepare together the test procedure for assessment of results.

**Figure 42: Example of a show room organised by a Member “Train Laboratory of PRM Accessibility” (June-July 2009) with a scale 1 mock-up of a coach with innovative solutions and other several testing areas in front of the coach (courtesy of SNCF)**

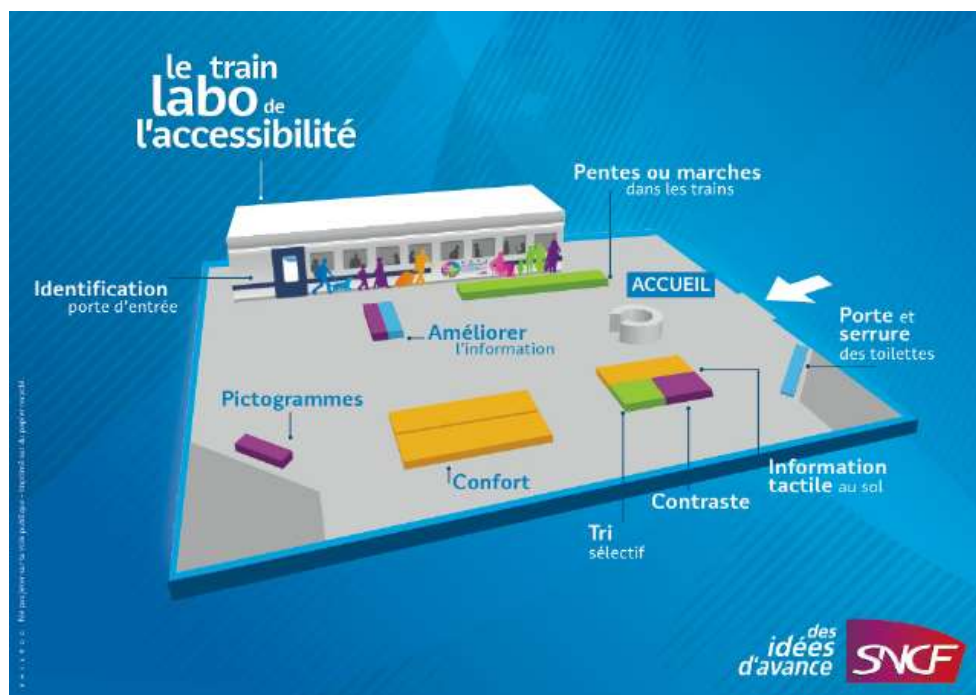

Photo offered by courtesy of SNCF

Example of a show room organised by a Member “Train Laboratory of PRM Accessibility” (June-July 2009) with a scale 1 mock-up of a coach with innovative solutions and other several testing areas in front of the coach.

Members will study and set up the scale 1 mock up and the Digital mock up.

At the end, the test on the mock up will valid the assumptions and benefit considered on this TD (ergonomic, technical and economic validation).

Members will quantify the profits on one or more concrete cases.

The members will also use the result of Roll2Rail Interiors by testing the methodology for assessing attractiveness and comfort from the passenger’s point of view and valid that the solutions of modularity don’t degrade passenger comfort or attractiveness.

To optimise the budget and offer a maximum of result, a hybrid digital and physical mock-up will be realised:

- Physical mock-up to show the innovative prototypes and to test them (ergonomist, ...): seats, interiors wall, decors
- Digital mock-up to proposes all possibilities of the concepts

For better efficiency and cost-wise, the TD proposes to build the physical mock-up mainly for the part of the vehicle: physical mock-up shows one solution and the digital mock-up shows it in the realistic environment.

The digital mock-up could also show prospective solutions not selected to be realised in scale 1.

For the physical mock-up, studies will be realised and the composite pieces (and fixation systems) built.

Members will:

- give railway components (seats for example) and assemble the physical mock-up.
- for the digital model, Members are expected to realise studies and build the digital demonstrator (and virtual animation).
- collaborate on the 3D models to be integrated in the Digital mock-up.

Activities allocated to Open Calls: Realisation of the new metallic parts. Search of a specific innovative technology for Digital Demonstrator.

#### 1.5.7.6. Planning and budget

This working group wants to impulse innovative approach of interiors design with a short-term objective to allow operators to quickly specify these concepts in their requirements (refurbishment or new market): first work finalised in two years and the first useful feedback in 2018<sup>9</sup>.

TDs	TASKS	TRL	2015	2016	2017	2018	2019	2020	2021
<b>TD1.7</b>	<b>TRAIN INTERIORS</b>								
	1.7.0 Attractiveness rating methodology (Roll2Rail)	-							
	1.7.1 Needs & state of the art	-							
	1.7.2 Potentials & forces	2/3							
	1.7.3 Development	4/5							
	1.7.4 Demonstrators	5/6							

The estimated total budget for Train MIU TD is around 2,8M€.

<sup>9</sup> Legend of the Gantt chart:

- Orange dotted line: First milestone. Concepts are defined. TRL2/3.
- Green dotted line: Second milestone. Technologies implemented and validated in laboratory or small real scenarios. TRL 4/5.





## 2. IP2 – Advanced Traffic Management and Control Systems

### 2.1. Context and motivation

Control, command and communication systems should go beyond being only a contributor for the control and safe separation of trains and become a flexible, real-time, intelligent traffic management and decision support system.

Although ERTMS has become a worldwide dominant solution for railway signalling and control systems, it has the potential to offer increased functionalities and become even more competitive. Current systems do not sufficiently take advantage of new technologies and practices, including use of satellite positioning technologies, high-speed, high-capacity data and voice communications systems (Wi-Fi, 4G/LTE), automation, as well as innovative real-time data collection, processing and communication systems, which have the potential to considerably enhance traffic management (including predictive and adaptive operational control of train movements), thereby delivering improved capacity, decreased traction energy consumption and carbon emissions, reduced operational costs, enhanced safety and security, and better customer information.

Furthermore, ERTMS specifications do not cover all interfaces, or engineering and operational rules to the extent needed, meaning that different railways and suppliers continue to design their own solutions, thereby hampering interoperability and increasing costs.

### 2.2. Objectives of the IP and expected results

A key challenge for IP2 is to enhance the overall line capacity and contribute to life-cycle cost reductions and global reliability of the railway system, while maintaining the highest level of safety, thanks to a better management of signalling and supervision systems on “static” infrastructure by supporting the development of an intelligent Integrated Mobility Management (I<sup>2</sup>M) system.

IP2 will focus on innovative technologies, systems and applications in the fields of telecommunication, train separation, supervision, engineering, automation and security with a view to enhancing the overall performance of all railway market segments.

IP2 will support maintaining the dominance of ERTMS as a solution for railway signalling and control systems across the world.

Maintaining ERTMS as the basis of any evolution, IP2 developments will aim to go beyond main line railway ERTMS applications, with a view to extending the new signalling and traffic management system to all railway transportation segments (High Speed Lines, Urban & Suburban, Regional, Freight), integrating both existing ERTMS standards and typical CBTC functionalities already applied in urban and mass transit lines.

IP2 will ensure continuity and backward compatibility with the current signalling and supervision systems through ERTMS standards but fostering the highest integration possible in terms of technology, operational rules, engineering processes, supervision, and communication network.



Furthermore IP2 main goals are to speed up the time to market, improve interoperability, offer improved functionalities and standardised interfaces, reduce costs (CAPEX and OPEX), and achieve an effective and reliable public rail transportation network with the capability to interconnect and interpenetrate urban rail and main line solutions.

In order to achieve these very challenging main targets within S2R, IP2 foresees a strong integration of different technologies and systems not yet largely applied in the railway field (e.g.: satellite positioning, moving block).

The following table summarises the main objectives of IP2 and provides an overview of some of the concrete deliverables that can be expected to result from the activities undertaken in the IP.

Objective	Result	Practical (concrete) Deliverable
Line capacity increase	Better use of (existing or new) infrastructures by operating with more trains on the same line (higher headway)	Introduce standardized Moving Block System (based on “Absolute Braking Distance”) and ATO (up to GoA3/4) concepts in a wider range of rail transport segment markets (from Freight to Mass Transit). For the longer term investigate the application of the “Relative Braking Distance” concept as well.
	More flexible use of the vehicles on the line (in terms of covering different passengers/hour needs)	Introduction of Trains’ Virtual Coupling functionality to allow further flexible accommodation of the capacity of the line at peak times.
Operational reliability increase	Fundamentally more reliable technologies and components	Introduction of formal methods and testing process/tools to be applied – since specification up to commissioning phase – to key elements and systems the failure of which might cause major impact on line operation (e.g. signalling, telecom)
	Fundamentally simplified architectures, or architectures more suited to continued operation in case of failure	Train communications and control architecture based on new technologies allowing much lower physical complexity and enabling operation recovery in case of degraded modes.
Railway system life cycle cost reduction	Reduction in the capital cost of signalling and telecom infrastructures	Introduction of flexible architectures and application of operational and engineering standards, allowing a correct system design customisation to the requirements of different market segments (from Freight to Mass Transit) and, therefore, a reduction of overall investment cost. Definition of business model which deals with the impact of shifting capital investment from trackside to on board. The definition of a better authorisation processes, relying on lab methods rather than on on-track tests, will also guarantee a consistent capital cost reduction.
	Reduction of maintenance cost	By reducing as much as possible the number of electronic and mechanical components laid down along the line and concentrating them in a limited number of easily accessible areas. A larger introduction of auto-diagnostic functions to detect the status of more critical components will allow a predictive (and optimised) maintenance.
	Reduction in the consumption of energy	By introducing an appropriate ATO functionalities (with Grade of Automation from 2 to 4) and Intelligent Traffic Management in all rail transport market segments



### 2.3. Past and ongoing European & national research projects

IP2 will ensure strong continuity with several ongoing projects (e.g.: NGTC, UNISIG activities in the framework of the Base Line 3 BL3 evolution, GSA projects like STARS and ERSAT-EAV...).

Relations with ERTMS working groups will be ensured as many TDs of IP2 have common subjects. IP2 will have the opportunity to make use of TEN-T UNISIG Working Groups outcomes and deliverables as the basis to improve and carry out Technical Demonstrators.

Specifically, the following TDs have tight relationships with UNISIG Working Groups. Possible areas for interaction are also indicated in the following table:

IP2 TDs	UNISIG WGs	Areas for interaction
<b>TD2.1 Adaptable communications for all Railways</b>	Euroradio	Provide an adaptable train-to-ground IP communication system supporting backward compatibility for ERTMS, easy migration and capability to be resilient to radio technology evolution.
<b>TD2.2 Railway network capacity increase (ATO up to GoA4 – UTO)</b>	ATO over ETCS	The results of the TEN-T programme (GoA2 concepts and requirements) will be implemented (prototypes) and validated in order to provide a GoA2 solution for railway applications ready for deployment.
<b>TD2.4 Fail-Safe Train Positioning (including satellite technology)</b>	Train Localisation e.g. with satellites	Interoperable and safe absolute positioning of the train, mainly obtained applying the GNSS technology to the current ERTMS/ETCS core.
<b>TD2.6 Zero on-site testing (control command in LAB demonstrators)</b>	IOP	UNISIG IOP standards taken as the baseline in order to improve testing in LAB.
<b>TD2.11 Cyber Security</b>	Key Management	Input for TD2.11: Cyber-risk assessment of the ETCS solution carried out by TEN-T WG

In addition, the ongoing NGTC project, which should end in September 2016, is expected to provide inputs for IP2 TDs, as depicted in the following figure.

A slight overlap between NGTC and IP2 developments might happen, assuming a launch of IP2 TDs in mid-2016. This timing will enable an initial tuning of activities inside IP2 TDs in order to contemplate NGTC outcomes that actually are one of the inputs for the IP2 related TDs.

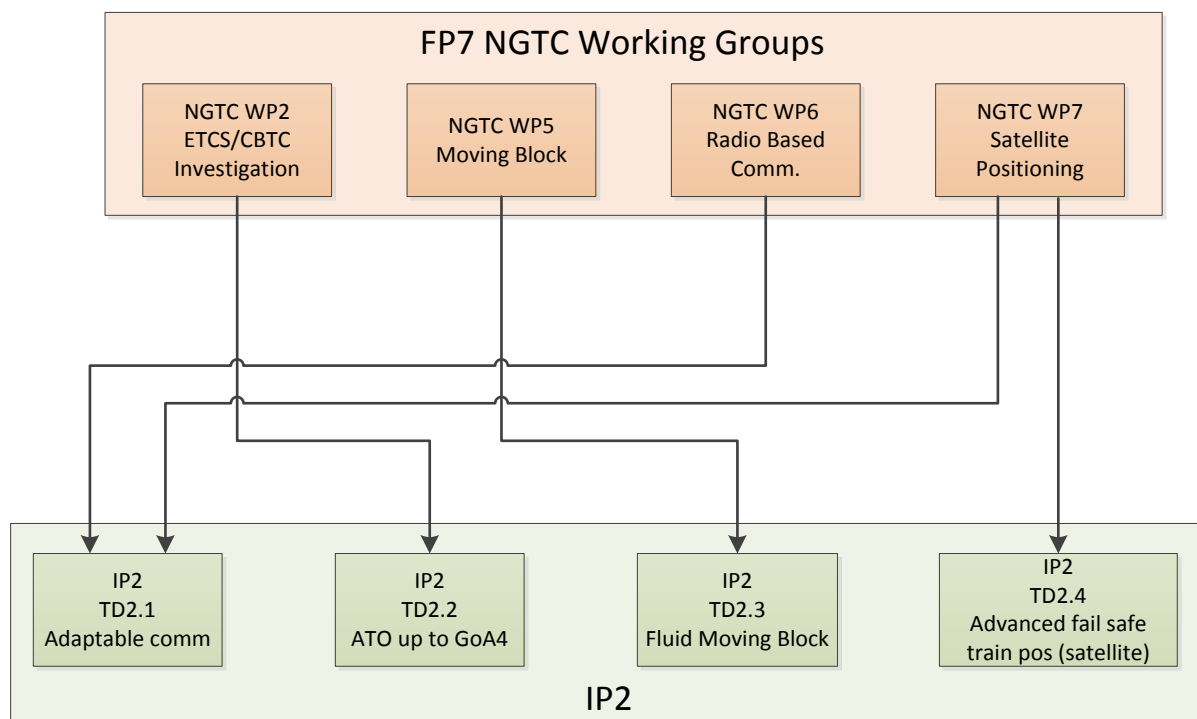
**Figure 43: Relationship with NGTC**

For what concerns satellite ongoing projects like STARS (Satellite Technology for Advanced Railway Signalling) and ERSAT EAV (ERTMS – SATELLITE) the objective is to characterise the railway environment, the GNSS performances and to validate the applicability of satellite navigation technologies EGNSS (including EGNOS and Galileo) for railway applications with high levels of safety (Safety Integrity Level-4). In accordance with the guidelines for the harmonisation of the European standard ERTMS, the projects aim to carry out an operational solution that can actually be proven on a railway test. The outcomes of these projects will be the inputs for further evolutions in IP2 in TD2.4.

## 2.4. Set-up and structure of IP2

### 2.4.1. Structure of the TDs

In order to address the challenges of IP2, eleven TDs have been identified. The interactions between these TDs will be strongly fostered and managed as an integrated and interrelated project in order to achieve a common and coherent new signalling and supervision system.

The work will be organised around the following research areas:

#### **Smart, fail-safe communications and positioning systems:**

- The development of a **new Communication System** (TD 2.1) able to overcome the shortcomings in current ETCS (European Train Control System) and CBTC (Communications-Based Train Control) and deliver an adaptable train-to-ground communications system usable for train control applications in all market segments, using packet switching/IP technologies (GPRS, EDGE, LTE, Satellite, Wi-Fi, etc.), in accordance with the findings of the ongoing NGTC project. The system will enable easy migration from existing systems (e.g.: GSM-R), provide enhanced



throughput, safety and security functionalities to support the current and future needs of signalling systems, and be resilient to interference and open to radio technology evolution. The focus will be as well in supporting the shift from “network as an asset” to “network as a service” model vision. Backward compatibility with ERTMS will be ensured.

- **Safe Train Positioning** (TD 2.4) via the development of a fail-safe, multi-sensor train positioning system (applying GNSS technology to the current ERTMS/ETCS core and introducing, as possible add-on for fulfilling the scope), the use of other new technologies (e.g. inertial sensors) or of other on board existing sensors (e.g. accelerometers, odometer sensors), aims to boost the quality of train localisation and integrity information, while also reducing overall costs, in particular by enabling a significant reduction in all track-side conventional train detection systems (balises, track circuits, axle counters, etc.).
- The development of **smart object controllers** (TD 2.10), consisting of autonomous, complete, intelligent, self-sufficient smart equipment (“boxes”) able to connect not only with control centres (e.g. interlockings) or other wayside objects and communicating devices in the area (by radio or satellite), but also e.g. with on-board-units. Such intelligent objects – knowing and communicating about their status conditions – would not only provide opportunities in terms of cost reduction and asset management improvement but also open new ways of railway network information management and control.

#### **Traffic Management Evolution**

- An **optimised Traffic Management System** (TD 2.9) through improved Traffic Management Operations with automated processes for data integration and exchange with other rail business services. The backbone of the new architecture will be a scalable, interoperable, and standardised communication structure able to be applied within an integrated Rail Services Management System. These features will be combined with new business service applications (e.g. advanced driver advisory system on area level, intelligent, automated and flexible dispatching systems including conflict detection and resolution) to allow for predictive and dynamic traffic management in regular and degraded situation. This Technical Demonstrator will use and integrate real-time status and performance data from the network and from the train, using on-board train integrity solutions and network object control functions, supported by wireless network communication.

#### **Traffic Management Evolution and Automation**

- An **optimised Traffic Management System** (TD 2.9) through improved Traffic Management Operations with automated processes for data integration and exchange with other rail business services. The backbone of the new architecture will be a scalable, interoperable, and standardised communication structure able to be applied within an integrated Rail Services Management System. These features will be combined with new business service applications (e.g. advanced driver advisory system on area level, intelligent, automated and flexible dispatching systems including conflict detection and resolution) to allow for predictive and dynamic traffic management in regular and degraded situation. This Technical Demonstrator will use and integrate real-time status and performance data from the network and from the train,

using on-board train integrity solutions and network object control functions, supported by wireless network communication.

- **On-board Automatic Train Operation (ATO)** (TD 2.2) aims to develop and validate a standard Automatic Train Operation (ATO) up to GoA3/4 over ETCS, where applicable, for all railway market segments (mainline/high speed, urban/suburban, regional and freight lines).

#### **Moving block (MB), train integrity and virtual coupling**

- **Moving Block** (TD 2.3) aims to improve line capacity by decoupling the signalling from the physical infrastructure and by removing the constraints imposed by trackside train detection thereby allowing more trains on a given main line, especially for high-density passenger services. The system will be backward compatible with existing ERTMS system specifications and enable evolutions towards CBTC functionalities for Urban applications.
- **Safe Train Integrity** (TD 2.5) aims to specify and prototype an innovative on-board train integrity solution, capable of autonomous train tail localisation, wireless communication between the tail and the front cab, safe detection (SIL-4) of train interruption and autonomous power supply functionality without the deployment of any fixed trackside equipment. This functionality will be developed notably for those market segments (Freight and Passenger Low Traffic lines) where such a function is not yet available using reliable existing on board features
- **Virtual Coupling** (TD 2.8) aims to enable "virtually-coupled trains" to operate much closer to one another (within their absolute braking distance) and dynamically modify their own composition on the move (virtual coupling/uncoupling of train convoys), while ensuring at least the same level of safety currently provided.

#### **Smart procurement and testing**

- The development of a set of **standardised engineering and operational rules** (TD 2.7) contributing to an **open standard interface** (if supported by positive business case) and **functional ETCS description model**, all based on formal methods, in order to ease verification and authorisation processes, eventually leading to improved interoperability, while reducing the need for extensive field tests in the future.
- The development of a **new laboratory test framework** (TD 2.6) comprised of simulation tools, testing procedures in order to carry out open test architecture with clear operational rules and simple certification of test results aims to minimise on-site testing (with the objective of zero on-site testing) by performing full laboratory test processes even if the systems are comprised of sub-components of different suppliers. The test framework will also allow remote connection of different components/subsystems located in various testing labs.

#### **Communication Network and Security Systems:**

- **Cyber-Security** (TD 2.11) will aim to achieve the optimal level of protection against any significant threat for the signalling and telecom systems in the most economical way (e.g.: protection from Cyber Attacks and Advanced Persistent Threats coming from outside).

All the IP2 Research Areas and relevant TDs are closely linked between them. Strong connections are already foreseen towards other Innovation Programmes and/or Cross cutting activities.

Figure 44 shows the expected links and interactions between TDs of IP2, as well as with other IPs. Table 10 also shows in detail the relationships for each TDs and also reveals the big challenge of IP2 which is to foster the evolution of a whole and interactive signalling system.

**Figure 44: IP2 Research & Innovation relationships**

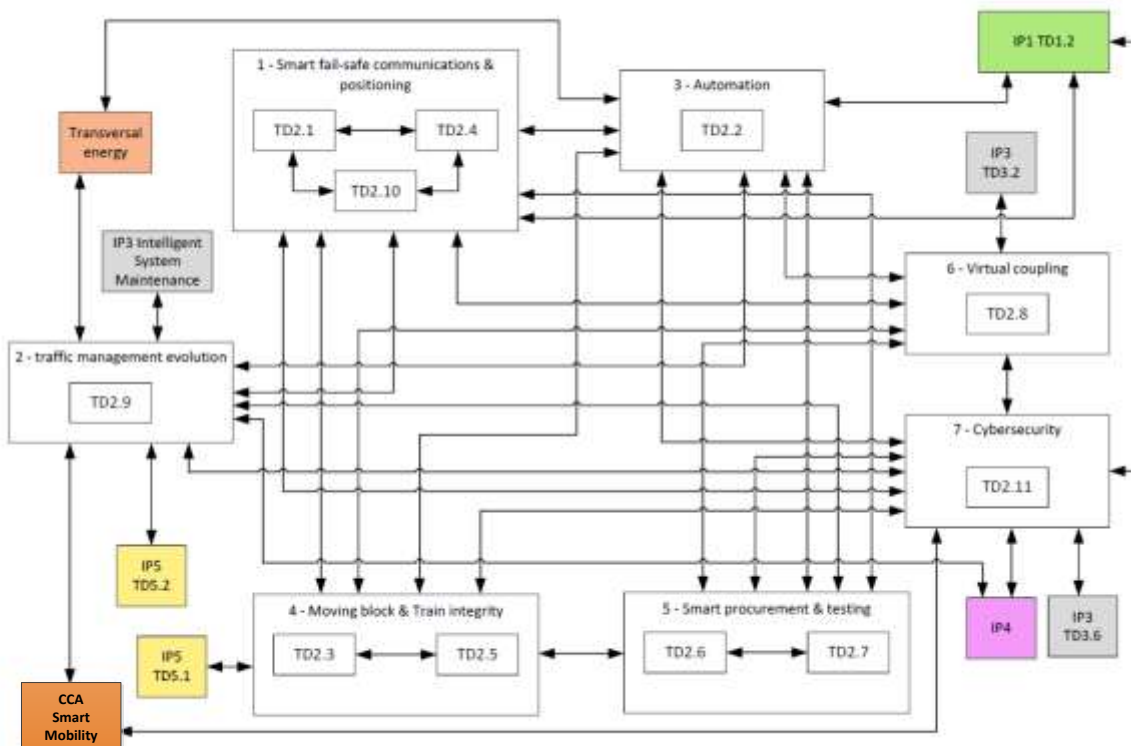



Table 10: IP2 – Links &amp; Synergies between TDs and with other IPs and projects

			S2R IP2										
			TD2.1	TD2.2	TD2.3	TD2.4	TD2.5	TD2.6	TD2.7	TD2.8	TD2.9	TD2.10	TD2.11
S2R IP2	TD2.1	Radio Based Communication		X	X	X	X			X		X	X
	TD2.2	ATO up to GoA4	X		X	X	X	X	X	X	X	X	X
	TD2.3	Moving Block	X	X		X	X		X	X	X		X
	TD2.4	Satellite Positioning	X	X	X		X		X		X		X
	TD2.5	Train Integrity	X	X	X	X			X	X			
	TD2.6	Zero on Site Testing		X					X	X		X	X
	TD2.7	Formal Methods		X	X	X	X	X		X			X
	TD2.8	Virtual Coupling	X	X	X		X	X	X				X
	TD2.9	TMS evolution		X	X	X						X	X
	TD2.10	Smart Radio connected (wayside object)	X	X				X					X
	TD2.11	Cyber Security	X	X	X	X		X	X	X	X	X	
S2R IP1	TD1.2	TCMS	X			X	X			X			
S2R IP3	TD3.2	Next Generation Switch&Cross.								X			
	TD3.6	Dyn. Railway Inform. Management Sys.									X		X
	TD3.8	Intell. System Maint. Engin&Strateg.									X		
S2R IP4										X		X	
S2R IP5	TD5.2	Access&Operation								X			
FP7 NGTC	WP2	ETCS/CBTC investig.		X			X				X		
	WP3	Technical Coherence		X							X		X
	WP4	Message Structure		X									
	WP5	Moving Block			X		X			X	X		
	WP6	Radio Based Comm	X				X					X	X
	WP7	Satellite Positioning				X	X						
Transversal Energy			X							X			
CCA Smart Mobility			X							X		X	

## 2.5. The Technical Demonstrators of IP2

### 2.5.1. TD2.1: Adaptable communications for all railways (quality of service, interfaces to signalling)

#### 2.5.1.1. Concept and objectives of the Adaptable communications Demonstrator

##### Objectives

This TD aims to provide an adaptable train-to-ground IP communication system with enhanced throughput, safety and security functionalities to take advantage of new technologies, supporting the current and future needs of signalling systems and voice services. Backward compatibility for ERTMS, easy migration, and capability to be resilient to radio technology evolution will be demonstrated.

The following table summarises the **objectives** and related deliverables of this TD:

**Table 11: Objectives and deliverables of the TD**

Objectives	Result and Practical (concrete) Deliverable
Definition, development and test of prototypes of a train-to-ground radio system answering to the current specification of ETCS and CBTC systems, including voice services but also added requirements to support enhancements of the signalling system foreseen by other TDs to improve the quality of services for users or reduce the costs (as communication with wayside object controllers or for TCMS)	Demonstrate the technical feasibility of the signalling requirements on all types of rail networks (high speed/mainline rail, urban dense and regional networks) including with site test via development and test. The development of prototypes by different teams will allow showing interoperability or show combination of different radio technologies.
Design a “technology independent” system, avoiding as far as possible any specific railway solution to reduce initial cost. Allow future evolutions of the radio bearer without impact on the reliability of the signalling system(s), to keep the cost of the system as low as possible during the time	Demonstrate the technical feasibility of the concept with prototypes using two different radio links and share the results with TCMS
Address convergence of metro and railway (GSM-R/EIRENE) voice services, standardisation of function and services with a technology independent approach to share cost and allow interoperability	Reference architecture with standard interfaces and QoS requirements focused on signalling, development and demonstration of the voice services in at least one prototype.
Encompass new business model definitions supporting the shift from "network as an asset" to "network as a service" model vision. Demonstrate in which conditions it could be possible to use public networks instead of dedicated networks	Business model(s) proposals and architecture allowing for the addition of new services (especially TCMS) within the same network if technically possible (under signalling QoS constraints)

### **Concept and approach**

To enable a smooth migration from GSM-R to a new technology for ETCS communication that will respond to the specific needs of new lines or new portions of line while keeping backward compatibility and interoperability with lines using previous generations of the radio, the concept to be demonstrated will comprise an On-Board-System with a core function supporting the interface with the signalling system, voice and other demanding applications, and the possibility to have several train-to-ground radio links, allowing an opportunistic use of an available network(s).

The concept could also allow using public networks for communication, either as fall-back or with several technologies combined to reach the requested level of quality of service. The system can also be seen in a layer perspective where the different train-to-ground links are represented by different "access" modules and their specific quality of service capacities and feedback information. That vision will also allow shared development and modularity of the prototypes.

Figure 45: General Scheme

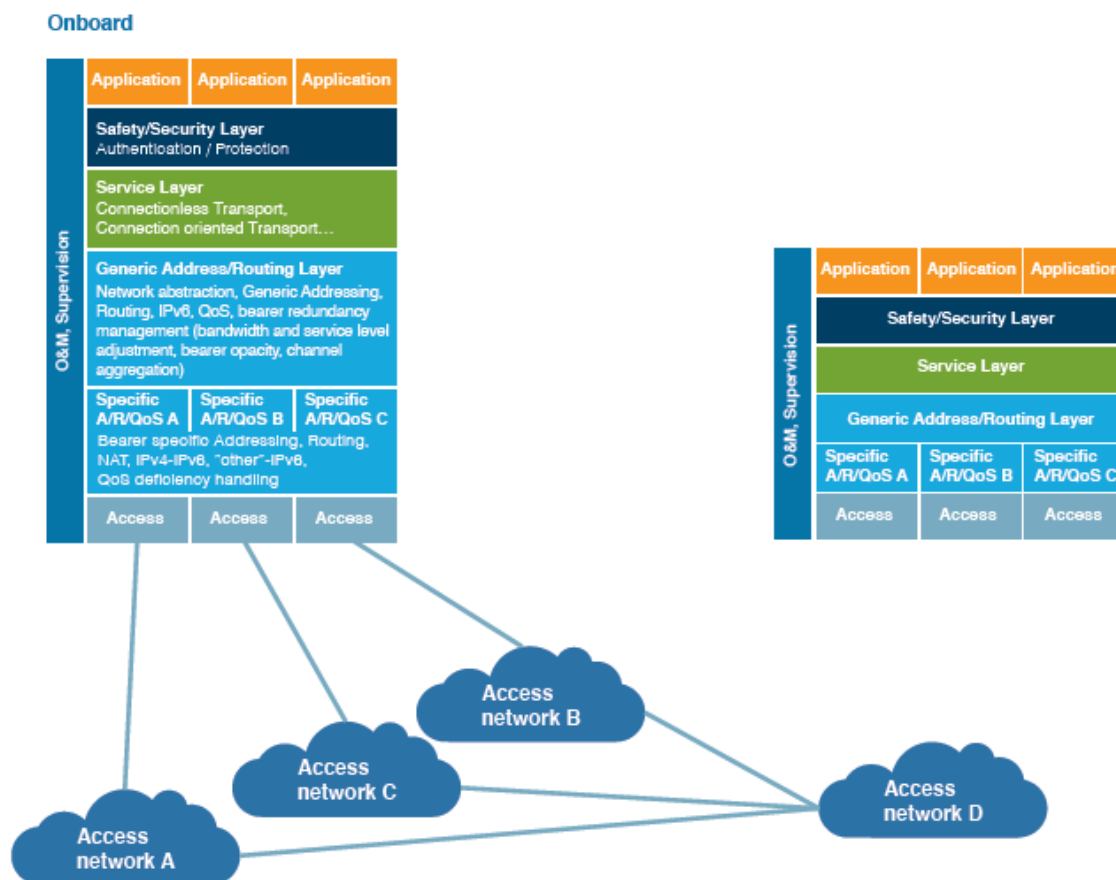

Being the support of the transmission of data used by other TD, there will be necessarily interaction with them to collect the communication requirements for their new features (for example throughput or latency needs, etc.) at the beginning of the project, and to align wishes and current possibilities during the project. It will be the case in particular with TD2.2 and TD2.3. To avoid disturbances between different wireless systems on the trains, coordination on the usage of the frequencies will be ensured with the "wireless TCMS" part of the TD1.2.

Signalling has to ensure that the system is always kept in a safe state and at the same time must prevent the trains from becoming "unreliable". Therefore this TD will thoroughly investigate the expected availability and quality of the train-to-ground links and exchange the resulting requirements with TD1.2. The system of communication is also a key point regarding IT-security, therefore the "cyber security" aspects objects of TD2.11 will be taken into account from the beginning and adequately aligned with the security task of that TD.

### 2.5.1.2. Technical ambition of the Adaptable Communications for all Railways

ERA has initiated a study for the evolution of the railway communications system, which already gives an image of the current situation and of the planned spectrum evolution and the trend for the communication technologies. The need for a solution "independent from radio bearer" is highlighted, and among the scenarios, the use of multiple technologies especially on the terminal side is seen as a fair or good candidate.



**This TD aims to bring these ideas into reality with more detailed definition and specification, and above all with the development and tests including on site, of prototypes.**

**It will also provide a more detailed scenario(s) for new business models to create a vision of « communications as a service ».**

Together with UIC, ERA is also working to define the operational and functional requirements for such a system, which will be used as a basis for our work.

ETCS over GPRS TEN-T project provides basic system demonstration for ETCS with packet switched communication, pointing out the modification required in the Euroradio layer specifications (as today this is limited to GPRS only, for LTE or all subsequent technologies, modification will be necessary).

FP7 NGTC project will provide signalling user requirement specifications sorted by common requirements for mainline and urban (CBTC requirements from urban operators), and specific or different ones. It will also provide an analysis of existing technologies and based on the specificities of mainlines and urban domain, it will conclude if the same technologies could be used or not on all domains with reasonable costs.

The new following technical points will be addressed:

- Definition of a fixed interface with the signalling system, irrespective of the utilized radio network technology, with defined and standard interfaces between the radio modules and the upper layer, to allow a transparent evolution of the radio bearer
- Specification of interfaces with safety related voice services (based on GSM-R and EIRENE requirements) independent of the IP communication system, and prototype and test of such an application.
- Investigation of new functionalities and related technologies (routing capabilities, vertical handover among mobile heterogeneous networks, use of network redundancy, etc.) such as pursued by TCMS train-to-ground links. In combination with information about Quality of Service achieved by the different links, it could in some cases allow the use of a public network instead of the dedicated network.
- Consideration of satellite communication technologies in view of their great promises consisting in coverage of large areas, growth in bandwidth, no wayside communication infrastructure, interoperability, and no requirement for roaming.
- Demonstration, including with tests on real conditions, of the capacities of the emerging technologies to fulfil the key requirements such as throughput, packet loss rate, quality of service, latency, and their stability when the train is moving, checking the possible impact.

### ***2.5.1.3. Specific Demonstration activities and contribution to ITDs/SPDs***

Two demonstrators will be developed to demonstrate that a technology independent approach based on packet switching/IP based radio communication is suitable to fulfil the need of signalling applications for all the railway segments.



One goal will be to demonstrate the possibility to integrate a number of heterogeneous technologies and communication protocols into one network, showing how this concept of radio bearer independent system allows a smooth and low cost migration between successive generations of radio technologies, and can be completely transparent for the signalling application.

On board middleware in charge of the transparent link selection will be therefore implemented. It is responsible for the decision of the optimal physical link to be employed, bringing either additional bandwidth by aggregation of links or increased availability of the communication if two heterogeneous channels are available on wayside, depending on the need of each specific application.

The concept of Cognitive Radio and the use of Software Defined Radio and Software Defined Network will demonstrate the possibility to be as much independent as possible from the hardware platform, especially for the radio modules

One demonstrator will apply this general concept with on-board radio modules focused on the needs for freight and high speed/mainline segment.

The other one will apply it focused on the needs for urban and suburban segment.

One radio module should use a common technology in both prototypes, to demonstrate the interoperability and the possibility to address mixed traffic networks which may contain high speed, urban/suburban and freight traffic.

A big challenge will be also to integrate services for IP voice, supporting EIRENE functionalities such as "follow-me", Location-Dependent-addressing and all the emergency call services within the high speed and main line prototype. (Here is a huge dependency on the feature availability on the ETSI roadmap, e.g. Group Call that is scheduled for a later LTE release). The expected outcomes of this development are a better understanding of the interrelationship and dependencies of

Satellite link would be also integrated, as a good solution for regional lines.

This demonstrator should be tested individually on field, to prove the concept including interoperability. They will be also integrated as a key element of each IP2 technology demonstrators.

### 2.5.1.4. Impact of the Adaptable Communications for all Railways

**The contribution of the TD to the strategic objectives of Shift2Rail is summarised in the following table:**

Strategic Aspect	Key Contribution from the TD
Support the attractiveness and competitiveness of the EU industry	<ul style="list-style-type: none"> <li>• Use of commercial technology to avoid specific development for the railway and therefore additional cost</li> <li>• Tangible benefits for the end user:               <ul style="list-style-type: none"> <li>○ LCC reduction (through sharing of the communication network or possibility to use public network in some conditions)</li> <li>○ Additional performance and service</li> <li>○ Support to capacity increase: where the current performances of the GSM-R are currently a bottleneck, the new system defined by the TD should bring the necessary communication capacities to apply the enhancement planned by the other TDs</li> </ul> </li> </ul>
Help European rail industry to consolidate its leadership on the global market	<ul style="list-style-type: none"> <li>• The communication technology is in constant evolution and the TD will take that situation into account: the modular architecture will allow applying the latest convenient technologies on emerging market, while nevertheless ensuring backward compatibility with already deployed ERTMS in Europe, allowing a migration phase. The radio bearer could be transparently adapted to the specific conditions to keep the costs as low as possible (ex: use of satellite communication in large area few populated, to save the cost of a wayside communication infrastructure)</li> </ul>
Achieve the Single European Railway Area	<ul style="list-style-type: none"> <li>• Interoperability will be provided, including with a solution suitable for the urban/suburban domain; answering either to the needs of current CBTC or to an enhanced ETCS.</li> </ul>

#### **Expectation for exploitation and possible market uptake**

Due to the programmed end of the GSM-R, the market is already requesting a decision about which system should be installed to support future lines, and organize the maintenance and migration concept for the lines already equipped with GSM-R. As the proposal will bring

1. A demonstration of technologies in a real operational environment to give credibility and clearly show benefits
2. A definition of interfaces with the signalling system(s) (ETCS and CBTC)
3. A common standard architecture preferably compatible and coordinated with TCMS radio communication

it will be a key input point to take the final decisions.

Additionally, by ensuring precedence of signalling related train-to-ground radio communication over non-safety-related communication the QoS requirements (see Euroradio Requirements) of signalling can be asserted and at the same time a best effort additional communication for non-safety related radio services such as conceived by TCMS can be achieved.

Using commercial technologies, the TD does not aim to modify or create new technical standards in the telecommunications field; nevertheless it should also give strong argument to discuss the need for reserved bandwidth or conditions of sharing and coordination.

#### ***2.5.1.5. Implementation of the work programme***

##### **Overview on the tasks of this TD**

- T2.1.1 User requirements
- T2.1.2 Business model
- T2.1.3 Specification of the Communication System
- T2.1.4 Guideline for a choice of Technology for mid-term implementation
- T2.1.5 Development of prototypes; test definition and Lab test
- T2.1.6 Field test

##### **Description of the tasks**

###### **T2.1.1 User requirements**

The objective of this task will be to gather the user operational and functional requirements for the future system, taking into account the work done previously by EIRENE, ERA, UIC and NGTC, and the estimated new needs from Shift2Rail other TDs, especially TD1.2 TCMS.

A specific focus of TD2.1 lies on asserting signalling functionality.

The S2R members will:

- identify the state of the art's review and functional requirement specification from both mainline and urban operators, bringing in this exercise the experiences from the field. This will ensure that all the requirements are taken into account
- assess the feasibility for that task.

###### **T2.1.2 Business model**

The objective of that task is to define some possible business model(s) to reduce the costs of the communication system, shifting from "network as an asset" to "network as a service" model vision.

It will include studies about possible synergies with other similar markets (ITS, blue-light), possible additional services such as TCMS which could share the network if the margin in terms of throughput are sufficient and the guaranty of QoS sufficient for the signalling system, and the coordination with external stakeholders addressing the spectrum resource management issues.

Open Calls: Universities and Telecom industries could be asked to bring their experiences in business model, including in the context of legacy upgrading. An early open call launched in 2015 should allow starting that task as soon as possible.



### **T2.1.3 Specification of the Communication System**

The objective of that task is to define the technical specification of the communication system including overall architecture, definition of interfaces with user application, addressing, QoS requirements, security, specification of end-to-end protocols and of the principles for operation and supervision of the communication system, and dimensioning rules using traffic models

Specific attention to 3GPP recommendation will be paid, in particular it will be checked how some blocks defined in this framework could be used, either directly or as a basis. A special focus will be made on how to fulfil the Voice over IP needs as described in the functional requirements of EIRENE standard. Special attention will be paid to the railway emergency call service (call pre-emption, group call communication, fast call setup, call acknowledgement).

During that task, S2R members should also support the standardisation of the communication system of the future.

### **T2.1.4 Guideline for a choice of Technology for mid-term implementation**

The objective of that task is to define a guideline to choose suitable technologies, and as first step, identify those used for the prototypes. In addition, a guideline for standardised technologies will be provided.

The guideline will take into consideration the characterisation of radio features in urban and railway environments, taking into account the specific nature of these environments – high mobility, frequency selective fading, distribution of resources in the radio channel, etc. – to ensure the quality of the service.

Several S2R members plan to collaborate for that task and cover the entire budget for the task.

### **T2.1.5 Development of prototypes; test definition and Lab test**

The objective of that task is to develop prototypes following the specification, to define the tests to be done and to provide the Lab test report. The demonstrator will take into account the guideline of task 2.1.4 and especially reflect the standardisation parts.

The S2R members will:

- lead the development of the freight, main line and high speed demonstrator for the integration of the Voice services and EIRENE functionalities. A big part will be the implementation of the railway emergency call service as defined by EIRENE. The expected outcomes are a better understanding of the interrelationship and dependencies of service enablers and areas where further performance improvements are required;
- lead the development of the urban and suburban demonstrator;
- focus on regional/freight lines application by providing simulation and development of a satellite-based communication prototype, also comparing RAM figures vs conventional ground network communication systems;



- develop an emulator of the radio system, with the characteristics of the targeted system defined in task T2.1.3, to check the consistency of these specifications in the railway environment;
- Analyse interferences between railway radio and public communications networks;
- Develop test strategy and test cases;
- participate in the area of Cognitive Radio Concepts, bringing in SDR experience and equipment as well as middle ware;
- Integrate the Voice services and fulfilment of EIRENE requirement (functionalities and the dispatcher subsystem).

Open Calls: 3<sup>rd</sup> parties for support of specific hardware in this field might be required.

### **T2.1.6 Field test**

The objective of that task is to demonstrate the capacity of the targeted technologies to answer the needs for communication of the different segments and to check the algorithms of link choice toward real field conditions. Within the field test it will be proven, which parts of the network architecture can be standardized.

One prototype will demonstrate the capacity of the targeted technology to answer the needs for communication of the freight and high speed/mainline segments. It will also support the demonstration with the VoIP and fulfilment of EIRENE specification part.

The other prototype will demonstrate the capacity of the targeted technologies to answer the needs for communication of the urban/suburban segment and will demonstrate the capacity of satellite communication to answer the needs for regional and freight segments.

The S2R members will:

- host field test stage (sub-urban and high speed/mainline);
- support the field testing phase in terms of aligning interfaces and supporting standardisation as well as the specific views architectures and technologies.

Open calls: providers of telecom devices and networks should be involved to provide devices and network access. RU/IM for a freight devoted trial site will be identified as well.

### **2.5.1.6. Planning and budget**

IP	TECHNOLOGY DEMONSTRATOR	TASK	TRL	2016	2017	2018	2019	2020	2021	2022	2023	2024
IP2	TD2.1 Adaptable communications for all railways	task 2.1.1 User requirements	1..3									
		task 2.1.2 Business model	1..2									
		task 2.1.3 Specification of the Communication System	1..4									
		task 2.1.4 Guideline for a choice of Tech. mid-term impl.	1..3									
		task 2.1.5 Dev. of prototypes; test definition and Lab test	1..4									
		task 2.1.6 Field test	5									

Estimated budget of the TD (including EU funding and Open Calls): 26.4M€.



## 2.5.2. TD2.2: Railway network capacity increase (ATO up to GoA4 – UTO)

### 2.5.2.1. Concept and objectives

#### Context

Mainline ETCS applications (including suburban) are currently generally limited to non-automated train operation (GOA1 present in both ERTMS level 1 and ERTMS level 2). The higher grade (GoA 2) is very rare on old systems and non-existent on ETCS ones.

The Operation Concepts formally defined by European Railway Operators (EEO) cover all Grades of Automation (GoA):

- GoA1: Non automated train operation (current situation): the train is driven manually; but protected by ETCS.
- GoA2: Semi-automated train operation: the train is driven automatically; but the driver is still in the cab to control the absence of obstacles in the track.
- GoA3: Driverless train operation.
- GoA4: Unattended train operation.

Even though the highest Grade of Automation is a proven technology in Urban operations, the operational constraints of the mainline transport system are significantly more complex than those of urban systems.

Compared to urban systems, the situation for mains line systems is more complex, see list below:

- The track layout is larger and more complex;
- The roll-out of any new system across the network takes many years, resulting in most journeys spanning lines with significantly different levels of fitment of infrastructure;
- There is a lot of different train types (with different performance levels and door layouts);
- Most trains are not all dedicated to a particular line; they may go anywhere in the country, with a few running anywhere in Europe;
- The absolute exclusion of people (as well as animals and other obstructions) from tracks is not practically achievable throughout a national network, that would mean vast lengths of fencing to install and maintain, and a multiplicity of over-bridges, road level crossings, footpath crossings, open station platforms, etc;
- Infrastructure Managers (IMs) and Railway Undertakings (RUs: train owners and operators) are often independent (at least in the European Union), and sometimes other parties are also involved, such as train leasing companies.

Despite the specificities of Main Lines, Automated Train Operation (up to GOA4) will be undoubtedly beneficial for the different kinds of railway operation:

- For High Speed Trains, Intercity lines, and Regional lines, Semi-Automated Operation (at least GOA2) will enhance the time-table adherence and optimise energy consumption;
- For Freight lines, both on heavy haul railroads and low density traffic lines, ATO (at least GOA2) will provide a smoother operation, bring energy savings and permit an optimal efficiency e.g. allowing “meet-and-pass” operation whenever possible;
- For Urban and Suburban applications, Driverless (GOA3) and Unattended (GOA4) types of operation will allow for high performance for lines carrying intensive inner Suburban and cross-city services having the full advantage of ETCS (interconnections, train types diversity, interoperability, etc.)

### **Objectives**

The aim of this programme is to investigate, develop and validate Automatic Train Operation over ETCS up to GoA4. The actual objectives are:

- To increase the transportation capacity on existing lines while limiting investment for new infrastructure;
- To reduce the operating costs, save energy and have a more efficient use of resources (e.g. staff).
- To make an important contribution to the vision of a fully automated rail freight system (TD5.6)

The following table provides a summary of the technical objectives for TD2.2 (ATO up to GoA4):

**Table 12: Objectives**

Objectives		Desired outcomes
Improved services and customer quality	Improved reliability	Quality of service is enhanced due to a better punctuality (Arrival and departure times will no more depend on the driver way to drive).
	Enhanced capacity	From 10% to 50 % capacity increase is achieved by reducing the minimum operational headway between trains due to automatic driving.
Reduced system costs	Energy Saving	From 12% to 20% by automatic driving based on optimised speed profiles taking into account the track configuration, the expected arrival time and the presence of other trains downstream.
	Operation Costs	Reduction of fixed cost (increase of staff productivity)
Enhanced interoperability	Respect and adaptation of TSIs Removal of open-points	The specification for interoperable ATO over ETCS will lead to TSI adaptation.



### **2.5.2.2. Technical ambition**

#### **State-of-the-art**

The state of the art is very different depending on operation type.

In 2013, for metros (urban rail), GOA2 is the rule for >50% of all metro lines in operation; GOA4 is the preferred choice for >50% of new lines being put in service or ordered.

In 2013, for all types of main lines (High Speed Line, Low Traffic/Regional Lines, Urban/Suburban), some countries have developed GOA1 (ATP – Automatic Train Protection), either

- with intermittent transmission (e.g. ASFA, EBICAB, KVB, PZB, TBL...); or,
- with continuous transmission (e.g. LZB and TVM).

All of these GoA1 systems provide continuous speed supervision in order to protect the train from exceeding the speed limitation.

GOA2 for main lines are very rare (e.g. the AVV system in the Czech Republic); and GOA3 and 4 do not exist.

In 2013, although links between ATP-ATO with other signalling or signalling-related functions (interlocking; train detection/track circuits; Automatic Train Supervision/Operating Control Centre, etc.) are quite seldom; they do exist with several metro applications.

The state of the art is based on proprietary solutions which are not interoperable. The existing systems are considering simple lines and operation schemes.

The progress will be to provide interoperable solution based on ETCS and able to manage the delivery of varied service patterns on a mixed-traffic network taking into account the complexity of main line operation (large interconnected network, different level of infrastructure fitment, lot of different train types not dedicated to a given line, etc...).

## Ambition

Compared to the current state of the art in Railways, the following benefits are expected from IP2 – TD2.2:

**Table 13: Benefits expected**

	High Speed Lines	Low Traffic Lines / Regional Lines	Urban/Suburban Lines
Punctuality	Journey times less variable and closer to Time Tables	Journey times less variable and closer to Time Tables	Journey times less variable and closer to Time Tables
Operational headway	Less variability in actual Journey time permits the Infrastructure Operator to foresee fewer “reserve time” in the Theoretical Time Tables. This leads to a lower operational headway and will increase the line capacity	Less variability in actual Journey time permits the Infrastructure Operator to foresee fewer “reserve time” in the Theoretical Time Tables. This leads to a lower operational headway and will increase the line capacity	Less variability in actual Journey time permits the Infrastructure Operator to foresee fewer margins in the Theoretical Time Tables. This leads to a lower operational headway and will increase the line capacity
Mean journey times	Less variability in actual Journey time permits the operator to reduce the Journey Times foreseen in the Theoretical Time Table.	Less variability in actual Journey time permits the operator to reduce the Journey Times foreseen in the Theoretical Time Table.	Less variability in actual Journey time permits the operator to reduce the Journey Times foreseen in the Theoretical Time Table.
Energy consumption	The trains are driven according to optimum Speed Profiles that minimises the energy consumption.	The trains are driven according to optimum Speed Profiles that minimises the energy consumption.	The trains are driven according to optimum Speed Profiles that minimises the energy consumption.
The staffing costs	Driverless and unattended operations allow for reduction of the required operation staff, thus contributing to enhance Railway Transport Productivity.	Not an issue.	Driverless and unattended operations allow for reduction of the required operation staff, thus contributing to enhance Railway Transport Productivity.

## European approach

By definition “Automatic Train Operation” Systems have an impact on trackside and train-borne as well. This requires that the operational rules and technical specifications are interoperable; permitting every equipped train to be operated on the different infrastructures.

The Railway companies will not be able to deploy such a system taking into account the operation constraints which could be specific to other companies. This is true for Infrastructure and Train Operation companies as well.

Consequently, the evolution towards higher Grade of Automation should be made with an approach which is similar to ERTMS and requires a European approach.



### **Contribution to TSIs and standards**

The main deliverable of IP2-TD2.2 is an interoperable system specification for:

- GoA2 (Semi-automated operation) in a first stage;
- GoA3/4 (Driverless or unattended operation) in a second stage including migration strategy from GoA2 to other Grades of Automation.

These specifications will be proven by “proof of concepts” and field test activities.

These specifications will be submitted to ERA in order to provide new TSIs and standards dedicated to Automatic Train Operation (up to GoA4) applicable on European Railway networks and trains.

#### ***2.5.2.3. Specific Demonstration activities and contribution to ITDs/SPDs***

##### **Demonstrators**

The validation work that has to be done for both solutions (GoA2 and GoA3/4) will be based on “Factory Test Bench” demonstration and on a “Pilot Line” demonstration.

The “**Factory Test Bench**” demonstrators will include:

- actual ETCS platforms (European Vital Computers (EVC) upgraded in order to support ATO features;
- train simulators in order to simulate trains movement in accordance with ATO and EVC controls;
- track simulators in order to simulate routes locking and track circuit occupancy;
- Traffic Management System (TMS) simulators for on-line operation data computation (stopping/passing points with expected arrival and departure times).

The test bench will be configured with actual track layouts and train characteristics in order to analyse the different types of operation (High Speed Line, Low Traffic/Regional Lines, Urban/Suburban).

The “Factory Test Bench” demonstrator will permit:

- the demonstration of the implementation of ATO features over the existing ETCS platform;
- the validation of these features against operators requirements;
- the validation of the test scenarios, the aim of which is to guarantee ATO interoperability.

The “**Pilot line**” demonstrators will involve actual signalling subsystems: TMS, Interlocking and ETCS upgraded with ATO features.

Different pilot lines will be tested in order to demonstrate ATO benefits for the three operation types mentioned above.



In collaboration with TD 5.6 (Autonomous Train Operation), a Pilot Line will demonstrate ATO functionality for freight traffic. This Pilot Line (dedicated to freight operation) is in the scope of TD 5.6. It will implement prototypes developed in the scope of TD 2.2.

TD 5.6 will contribute to the specification to ensure that the automated freight operation will be fully taken into account.

Tests on pilot lines will provide:

- a full scale demonstration of the technical feasibility of implementing ATO over ETCS;
- a full scale demonstration of ATO behaviour within actual Mainline operational constraints (e.g. mixed traffic with fitted and non-fitted trains);
- evidence of the interoperability of implemented solutions;
- a statistical analysis of operational benefits (performance and energy consumption).

In order to demonstrate the interoperability, several trains will be equipped with different UNISIG supplier solutions.

The operation benefits statistical analysis will be based on the comparison with existing manually driven trains and ATO fitted ones.

#### **Link to other ITD/SPD**

The work associated with ATO demonstrators will strongly interact with IP1 and IP5 (for the fitting into a vehicle, respectively for High Speed, Intercity or Freight types of rolling stock), with IP3 (for the infrastructure part and any interfaces there) and other forecasted IP2-related topics, such as:

- IP5 – TD5.6: “Autonomous Train Operation”;
- IP2 – TD2.1: “Adaptable communications”;
- IP2 – TD2.4: “Fail-Safe Train Positioning”;
- IP2 – TD2.3: “Moving fluid block”;
- IP2 – TD2.7: “Formal methods for smart signalling system”; including formal specs;
- IP2 – TD2.9: “Traffic Management System”
- IP2 – TD2.11: “Cyber system security including key management.”

And possibly also:

- IP2 – TD2.5: “On-board train integrity”;
- IP2 – TD2.6: “Zero on-site testing”;
- IP2 – TD2.8: “Virtually-coupled train sets”;

- IP2 – TD2.10: “Smart radio-connected wayside objects”.

In particular:

1. TD 5.6 will contribute to ensure that the automated freight operation will be fully taken into account.
2. The absolute positioning coordinates needed by the ATO system in relation with the relative positioning which is used by the ETCS Onboard Unit will be treated in conjunction with IP2 – TD2.4 and IP2 – TD2.9.
3. The trackside ATO management is considered to be a subsystem separated from TMS and connected to the TMS via standard IF of the Integration Layer which will be developed under TD2.9. S2R transverse topic I<sup>2</sup>M (“Innovative Mobility Management”) will also be closely linked with IP2-TD2.2.

#### **2.5.2.4. Expected impact**

##### **Main benefits**

Thanks to the operational headway reduction, it is expected that IP2-TD2.2 developments will bring 10 to 50% (or even more) line capacity increases. The final figures will depend on several parameters: the existing line or network characteristics, the available or possible extensions and adaptations of the infrastructure, the characteristics of existing and new rolling stock are among the parameters that will have to be considered.

The consequence of the operation margin improvement is that the amount of trains per hour may be increased without changing the infrastructure or the signalling.

Energy savings depend on the type of operation and type of trains. Recent studies have demonstrated that automatic driving can lead to a savings of between 12% and 20%.

The benefits associated to Staff Reduction depend also on the type of operation.

For example, the use of automatic unsupervised turn back would allow for the reduction of the staff numbers.

In GoA3/4, the staff reduction is, by definition, much more important; even if the operator must, in these Grades of Automation, still foresee people on site in order to manage the degraded modes.

##### **Contribution to expected Shift2Rail impacts**

ATO over ETCS (up to GoA3/4) will completely change the way future Railway Lines are operated.

Without imposing heavy investment to create additional infrastructure, it will:

- improve the services and the customer perception of quality by improving the punctuality and by increasing the transportation capacity in order to face the growing demand in public transport over the coming decades.
- Reduce the operation costs by saving energy and reducing staff





- Enhance interoperability by producing “ATO over ETCS” interoperable requirement that will be used to modify the current ETCS TSI.

#### **Specific areas in which the project results can have a genuine influence**

ATO (up to GoA4) will have a genuine influence on the following:

- Environmental impact (by the reduction of energy consumption)
- Public transport attractiveness (by the reduction of operating costs, Public Authorities will have the possibility to invest in public transport to offer better).
- Safety in Public Transport (higher Grade of Automation globally enhances the safety of the operation)
- The quality of service (shorter mean travel times which are more predictable enhance the punctuality and the quality of service. This will lead to increase of passengers using public transport).

#### ***2.5.2.5. Implementation of the work programme***

##### **Overview**

In order to be realistic, the evolution towards “unattended operation” (GoA4) must be implemented incrementally.

It should start with “Semi-Automated” operation (GoA2) on applications where the benefits could be achieved rapidly with GoA2.

The different steps from the current situation (GoA1 – Manual operation supervised by ETCS) to the highest Grade of automation (GoA4) should be backward compatible with the preceding situation in order to take into account the very long migration periods which characterize Main Line operation.

IP2 – TD2.2 (ATO up to GoA4) will take as its baseline the work being performed within:

- The TEN-T 3rdcall Technical Interoperability Requirement for ATO over ETCS (GoA2);
- The Operation Concepts updated according to the results of the European NGTC project.

Figure 46: Work Breakdown Stream

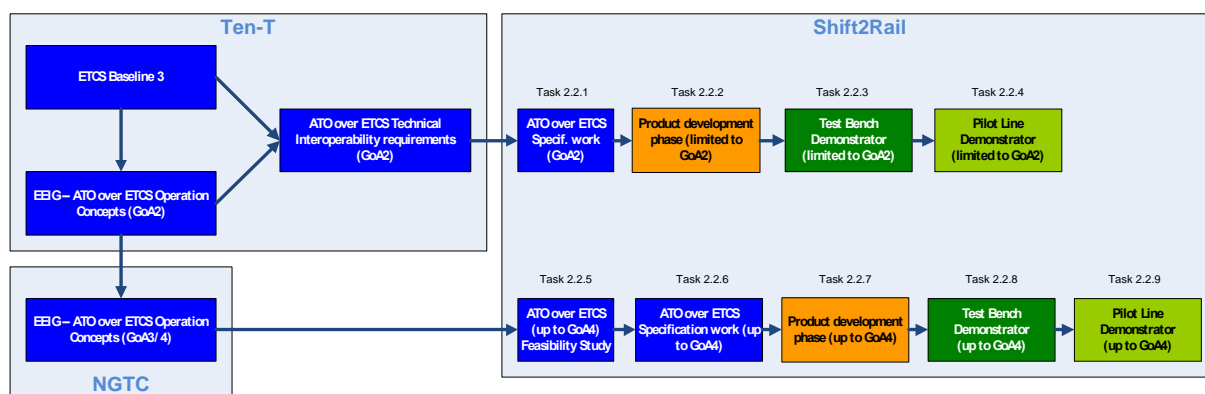

The results of the TEN-T programme (GoA2 concepts and requirement) will be implemented (prototypes) and validated in order to provide a GoA2 solution ready for deployment in 2019.

The results of NGTC (GoA3/4 operation concepts) will be studied, implemented and validated in order to provide a GoA3/4 solution ready to deploy in 2024.

### **T2.2.1. ATO over ETCS – GOA2 Specification**

In this task, the S2R members will:

- review the ATO over ETCS specification according the Operation Concepts update defined in NGTC, considering the impact over report of standardisation needs exposed under Mandate 486 for standardisation of Urban Rail to Interoperability implementation;
- prepare the prototyping and testing phase on demonstrators.

It will include:

- The specification of the off-site and on-site tests to be executed in order to demonstrate the interoperability of the GoA2 features;
- The consolidation of the GOA2 specification (output of TEN-T programmes) according to the results of test campaign performed in laboratory and in the pilot lines."

The S2R members will:

- guarantee the compliance with Operational Concepts;
- Develop clear and complete specification as the baseline for the following prototype development.

TD 5.6 will contribute to the specification to ensure that the freight and mixed operation at this Grade of Automation will be fully taken into account.

Additional contribution is expected as well in order to validate that Operational Concepts for ATO are covering the needs of all of the European Operators.



### **T2.2.2. ATO over ETCS – GOA2 Prototype Development**

#### *Summary of this task*

The aim of this task is to develop prototypes in line with the ATO over ETCS interoperable system specification developed for the GoA2.

The S2R members will:

- develop ATO **on-board** prototypes for different type of trains (electric or diesel/electric) and different type of operation (High Speed Line, Low Traffic/Regional Lines, Urban/Suburban);
- develop an ATO on-board application implemented in the EVC HW (integrated solution) providing a modular and non-regressive integration as ATO should not influence safety critical application;
- upgrade their existing on-board ATO in accordance with AoE specification prototype and in order to be interfaced with the ETCS-OB of other suppliers (separated solution);
- upgrade their existing ETCS wayside and on-board prototype in order to support the functions exported by ATO on current ETCS;
- test a prototype interfaced with an on-board ETCS from another supplier;
- develop a full ATO **trackside** prototype based on different approaches:
  - including the trackside ATO-SW module as part of TMS (Traffic Management System) for enhanced prediction quality of train movements;
  - developing the ATO trackside on a separate HW acting as a gateway between the TMS and the ATO on-board;
- focus on trackside functionality and will develop an interfacing ATO service separate from core TMS functions.;
- develop an “Autonomous ATO trackside” prototype intended to be integrated on existing TMS, without the need of changes in such TMS. A basic application software considering the same regulation and energy efficiency principles as the ATO On board will be included in this ATO-TS prototype. This will allow provision of an additional environment for the lab demonstration and testing of the complete GoA2 ATO system mixing prototypes of several suppliers, developed under different approaches;
- develop an ATO-TS partially integrated in the TMS which will be interfaced with a dedicated communication server compliant with the developed specifications.

### **T2.2.3. GOA2 Reference Test Bench Demonstration**

The aim of this activity is to develop test benches permitting to integrate prototypes from different suppliers.



It is required to perform tests in order to demonstrate:

- the expected performances in line with UG requirement;
- that the interoperability rules and interfaces (FFFIS) are respected;
- the MMI concepts for GoA2.

The S2R members will:

- develop a test bench based on the current ETCS interoperability platform modified according to the functions exported by ATO on current ETCS;
- supply the trackside and on-board part of the test platform to conduct cross-technical tests that ensure interoperability not only for the two parts of the ATO systems, but also for the two parts of test bench system;
- validate the AoE requirements (GoA2), thanks to test platforms, using 3 on-board prototypes and 3 trackside prototypes, using specific ETCS application.
- use the Test Bench Demonstrators in order:
  - to make tests using their on-board ATO connected to ETCS-OB;
  - to make tests using their trackside TMS/ATO connected to on-board ATO of other suppliers and interfaced with ATO-TS;
- validate the modified interoperability platform test bench;
- specify the operational scenarios to be tested;
- specify the operational scenarios and will participate to the comparison of results with specification sheet and the control of the TD's performance.

Additional Freight operational scenarios will be provided in the scope of TD5.6.

Additional contributions are expected to help building operational scenarios applicable for all of the European Operators.

#### **T2.2.4. GOA2 Pilot Line Demonstration**

The aim of this task is to validate AoE using 2 pilot trains and 2 pilot lines.

The S2R members will:

- host AoE prototypes on a pilot line and manage pilot tests in order:
  - to perform statistical analysis on operation benefits comparing to the existing manually driven trains;
  - to demonstrate the interoperability of GoA2 solution.



- participate to the comparison of results with specification sheet and the control of the TD's performance.
- upgrade with AoE 1 pilot train already equipped on-board ETCS;
- upgrade with AoE 1 pilot line already equipped with trackside ETCS level 2;
- provide a remote ATO pilot line demonstration;
- arrange necessary testing of its ATO-OB on its pilot train and ATO-OB on pilot trains with ATO-TS at a test circuit (fit for ETCS level 2) without adding cost to the project (via Additional activities to S2R).

Also TD 5.6 will host a Pilot Line dedicated to ATO over ETCS for freight operation.

#### **T2.2.5. ATO over ETCS – GOA3/4 Feasibility Study**

In this task, the S2R members will demonstrate, theoretically, that the expected performances in GoA3/4 could be achieved on the basis of ETCS (on paper and by simulations) and to identify the potential issues to address in the specification phase. This will include:

- the collection and the analysis of the corresponding Users Requirements;
- the identification of the hazards (PHA) of this innovative solution;
- a simplified model of system Architecture with the identification of all internal and external subsystems;
- a draft of system requirements specification.

The S2R members will also:

- update the Operational Concepts according the results of the feasibility study;
- assist the feasibility study providing a survey of existing operational procedures and national demands for ATO and defining market requirements for ATO in order to validate the operation concepts.

Additional contributions are expected as well in order to validate that Operational Concepts for ATO are covering the needs of all of the European Operators.

This activity is synchronized with TD 5.6.

#### **T2.2.6. ATO over ETCS – GOA3/4 Specification**

In this task, the S2R members will:

- review the ATO over ETCS specification (GoA3/4) according the Operation Concepts updated according to the feasibility study.
- prepare the prototyping and testing phase on demonstrators.



It will include:

- the definition of the mitigations for the hazards identified in the feasibility study;
- the identification of the impacts on current ERTMS specification;
- the specification of the System Requirements and Architecture of the overall ATO over ETCS;
- the functional specification of the interfaces and the exported constraints on the relevant external systems (e.g. interlocking, TMS, maintenance systems, etc.);
- the Functional Requirements for the reference Test Facility (this task is aimed to identify changes required to the ETCS test facility in order to integrate the new ATO function up to level GOA4);
- the specification of the functional tests to be executed in order to demonstrate the interoperability of the GoA3 and GOA4 features;
- the strategy to migrate from a given Grade of Automation to another;
- the update of all previous activities or deliverables according to the results of test campaign performed in laboratory."

The S2R members will also:

- guarantee the compliance with Operational Concepts;
- collaborate to have clear and complete specification as the baseline for the following prototype development.

TD 5.6 will contribute to the specification to ensure that the freight and mixed operation will be fully taken into account.

Additional contribution from other IM companies and from RU companies in order to validate that Operational Concepts for ATO are covering the needs of all of the European Operators will be expected.

### **T2.2.7. ATO over ETCS – GOA3/4 Prototype Development**

#### *Summary of this task*

The aim of this task is to develop prototypes in line with the ATO over ETCS interoperable system specification developed for the GoA3/4.

The S2R members will:

- develop two **on-board** prototypes considering different type of trains (electric or diesel/electric) and different type of operation (High Speed Line, Low Traffic/Regional Lines, Urban/Suburban);
- develop a full ATO **trackside** prototype;
- focus on trackside functionality and specifically address GoA3/4 implications on safety functionality.



### **T2.2.8. GOA3/4 Reference Test Bench Demonstration**

The aim of this activity is to develop test benches permitting to integrate prototypes from different suppliers.

It is required to perform tests in order to demonstrate:

- The expected performances in line with UG requirement;
- That the interoperability rules and interfaces (FFFIS) are respected;
- To validate the MMI concepts for GoA3/4.

The S2R members will:

- develop a test bench based on the current ETCS modified according to the functions exported by ATO on current ETCS;
- supply the trackside part of the test platform;
- deliver the on-board part of the test platform;
- validate the AoE requirements (GoA3/4) using 2 on-board prototypes and 2 trackside;
- validate the modified interoperability platform test bench;
- specify the operational scenarios to be tested;
- participate to the comparison of results with specification sheet and the control of the TD's performance.

Additional Freight operational scenarios will be provided in the scope of TD5.6.

Additional contributions are expected to help building operational scenarios applicable for all of the European Operators.

### **T2.2.9. GOA3/4 Pilot Line Demonstration**

The aim of this task is to validate AoE using 2 pilot trains and 2 pilot lines.

The S2R members will:

- host AoE prototypes on a pilot line and manage pilot tests in order:
  - to perform statistical analysis on operational benefits comparing to the existing manually driven trains.
  - to demonstrate the interoperability of GoA2 solution.
- participate to the comparison of results with specification sheet and the control of the TD's performance;
- upgrade with AoE 1 pilot train.

- upgrade with AoE 1 pilot line.
- provide a remote ATO pilot line demonstration

Also TD 5.6 will host a Pilot Line dedicated to ATO over ETCS for freight operation.

RU's are expected in order to host pilot trains and an additional IM in order to host 1 additional Pilot Line in another environment.

#### 2.5.2.6. Planning and budget:

IP	TECHNOLOGY DEMONSTRATOR	TASK	TRL	2016	2017	2018	2019	2020	2021	2022	2023	2024
IP2	TD2.2	task 2.2.0	N/A									
		task 2.2.1	3-4									
		task 2.2.2	5-6									
		task 2.2.3	6									
		task 2.2.4	7									
		task 2.2.5	3									
		task 2.2.6	3-4									
		task 2.2.7	5									
		task 2.2.8	6									
		task 2.2.9	7									

Estimated budget of the TD (including EU funding and Open Calls): 22.48 M€.

### 2.5.3. TD2.3 Moving Block

#### 2.5.3.1. Concept and Objectives

Moving Block is seen by a large number of Infrastructure Managers and Railway Undertakings as a way to increase significantly the capacity of railway lines which are already saturated or which will become saturated in the near future. The moving block techniques can not only improve the transport capacity of the lines, but also reduce the cost of the signalling installations and increase the reliability of railway transport.

Moving Block signalling has already been implemented by various suppliers for urban railways, typically within vertically integrated organisations, with captive rolling stock. It is not yet implemented to any large degree across other railway categories, where there can be many operators, with many train types, requiring full interoperability.

The objective of the Technical Demonstrator for Moving Block is to define, develop and test a high capacity, low cost, high reliability signalling system, based on Moving Block principles, applicable across all railway categories.

- High Capacity is based on the use of Moving Block principles, which permits decoupling of the infrastructure from train performance parameters.
- Low Cost is achieved by the reduction in the use of trackside train detection.
- High Reliability is achieved as a consequence of the reduction in trackside equipment associated with trackside train detection.





These are all contributions towards overall Shift2Rail objectives.

Each of these areas can have an impact on services for customers.

- Higher Capacity enables an increase in the number of train services which can be run over given infrastructure.
- Lower Cost is of interest to all, and potentially enables upgrading of railways which would not otherwise be upgraded, especially in the low traffic market segment.
- Higher Reliability can have a direct impact on services provided to customers.

It is also an objective of this TD to enhance interoperability. This will be achieved by working collaboratively on the specifications for the Moving Block Signalling System. Collaboratively agreed specifications will enable interoperability at several overlapping levels:

- Between equipment from different vendors;
- Between trackside and train-carried equipment;
- Between equipment owned and operated by different Railway Undertakings.

The concept of a Moving Block Signalling System is to use Moving Block principles to localise the trains, and to determine Movement Authorities.

The Moving Block Signalling System is the safety critical core of the signalling system required to achieve the capacity increase objectives of the Shift2Rail project. It is dependent on most of the other TDs within IP2, notably the following:

- TD2.1 Adaptable Communications
- TD2.4 Safe Train Positioning
- TD2.5 Train Integrity
- TD2.7 Formal Methods
- TD2.11 Cyber security

Together, these TDs will provide the safety critical layer of the Moving Block Signalling System.

In addition, the Moving Block Signalling System will interact with the Train Regulation and Traffic Management TDs within IP2:

- TD2.2 ATO
- TD2.9 Traffic Management

There is also a relationship between TD2.3 and TD2.8 Virtually Coupled Trains. TD2.3 is concerned with creating Technical Demonstrations of Moving Block signalling across all railway categories. TD2.8 Virtually Coupled Trains is researching solutions for further capacity and operational improvements beyond those achieved by Moving Block.

The relationships are shown in Figure 47.

**Figure 47: Relationship Diagram**

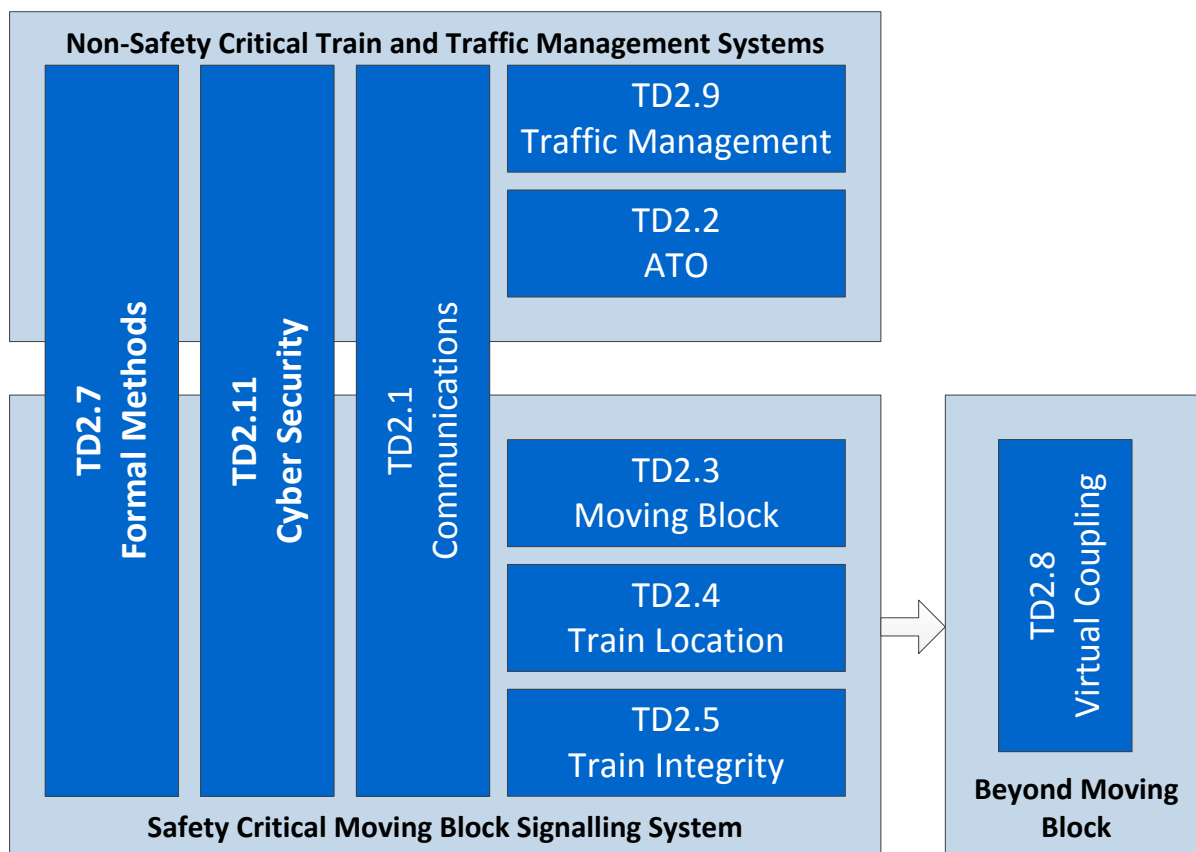

The Moving Block Signalling System will provide the safety critical layer of the signalling. Full usage of the increased capacity will then require the train regulation and traffic management systems.

The approach is to build the complete system, initially into Technology Demonstrators, and eventually into integrated Technology Demonstrators.

### **2.5.3.2. Technical Ambition**

Within Mass Transit systems, CBTC or similar systems can approach close to theoretical maximum capacities. However, this is achieved in vertically integrated railway systems, which in general do not interact with other railways, and which have one or a very limited number of different types of trains, with fixed train consists.

Within Main Line systems, traditional signalling systems have fixed blocks (Figure 48).

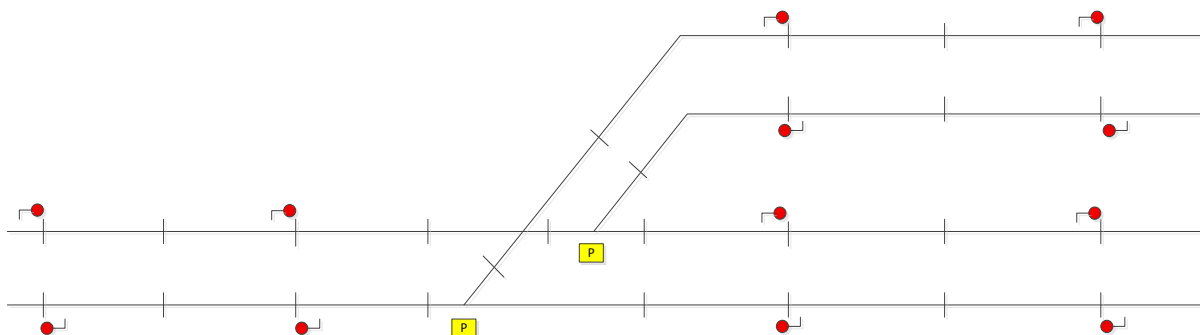
**Figure 48: Fixed Block layout**

The blocks are fixed during the design of the infrastructure, and then hard coded into the infrastructure, for example by the application of track circuits or axle counters.

There are also limitations based on signal sighting rules, cable routing and power supplies.

The ambition of the Moving Block signalling system is to remove the constraints imposed by hard-coding the train detection blocks into the infrastructure (Figure 49).

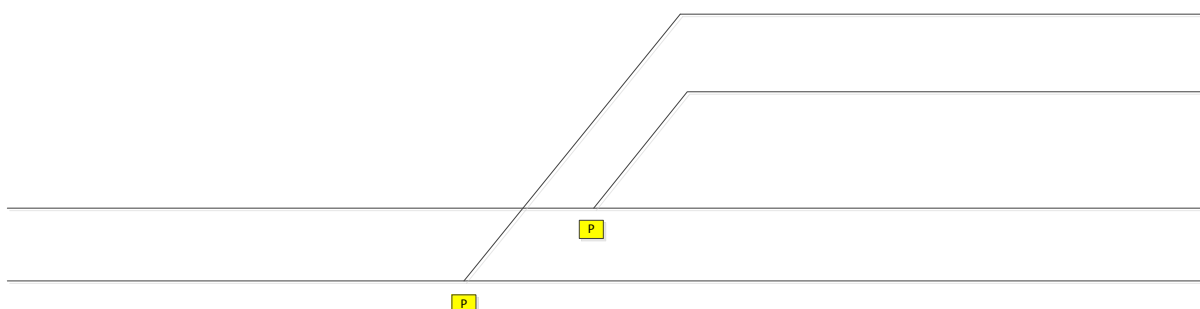
**Figure 49: Fixed Block removal**

Once the constraint of the hard-coded blocks is removed, the signalling system, and thence the traffic management system, can determine the best use of the infrastructure in terms of capacity for different types of trains, or under different traffic conditions.

In order for such a system to be accepted as a safe in the absence of trackside train detection, it is important that Train Integrity is provided (TD2.5).

As stated previously, such a Moving Block Signalling System without trackside train detection also has the ambition to reduce costs and increase reliability – both of these based on the overall reduction in trackside equipment.

### **2.5.3.3. Specific Demonstration Activities and Contribution to ITDs/SPDs**

This TD will provide a Technical Demonstration of Moving Block Signalling Systems, including prototype signalling equipment aimed at the different railway segments. This is Task 2.3.7 below.



This task will include demonstrations across different railway segments:

- Low Traffic and Freight segments
- Urban/Suburban segment
- High Speed and Main Line segments

In addition, there will be a Technical Demonstration of transitions in and out of Moving Block area, and of running with mixed equipped and non-equipped trains (mixed traffic).

The Technical Demonstrations will include updating of all system components required to realise the Technical Demonstrations. For example, there will need to be modifications to interlocking behaviour.

The Technical Demonstrations will be used to evaluate the impact of the new Operational Rules and Engineering Rules, including the impact on capacity, and the impact on the level of equipment required. They will also be used to demonstrate interfaces and interactions between the different components which make up Moving Block signalling systems.

The prototype signalling equipment within the Technical Demonstrations is expected to reach TRL 3/5.

There is potential to link the equipment from with TD2.3 Moving Block with equipment from other IP2 TDs, to create more integrated demonstrations, for example in ITDs/SPDs.

#### **2.5.3.4. Impact**

A Moving Block Signalling System enables the following:

- Increase in capacity, by decoupling the signalling from the infrastructure, and from being designed for the worst-case types of trains;
- Decrease in lifecycle costs, by reducing the quantity of trackside train detection equipment which is required;
- Increase in system reliability, as a consequence of the reduction in quantity of trackside train detection equipment.

The impact on different market segments is shown in the table below:

	High Speed Lines	Urban/Suburban Lines	Low Traffic Lines / Freight Lines
Capacity	Increase in capacity based on Moving Block principles	Increase in capacity based on Moving Block principles	Capacity is not an issue
Cost	Cost reduction based on removal of trackside train detection	Cost reduction based on removal of trackside train detection	Cost reduction based on removal of trackside train detection
Reliability	Increase in reliability, based on removal of trackside train detection equipment	Increase in reliability, based on removal of trackside train detection equipment	Increase in reliability, based on removal of trackside train detection equipment

There are potential barriers to realising the benefits described, for example:

- a) Removal of trackside train detection equipment is dependent on 100% fitment of trains with the train-carried component of the Moving Block Signalling System. There may be barriers of cost or organisation to achieving this, and thence barriers to realising the full benefits of the Moving Block Signalling System.
- b) There may be difficulty in reaching agreement on the revised operational rules, as they represent changes from current operational rules. This may particularly apply to operational rules relating to failure conditions.

### 2.5.3.5. Implementation of the Work Programme

The collaborative approach of S2R members will achieve performance of the tasks described below and also achieve the interoperability of the resulting systems, no matter if they are supplied by different vendors, or used by different Railway Undertakings.

The task breakdown is shown in Figure 50.

**Figure 50: Task breakdown**

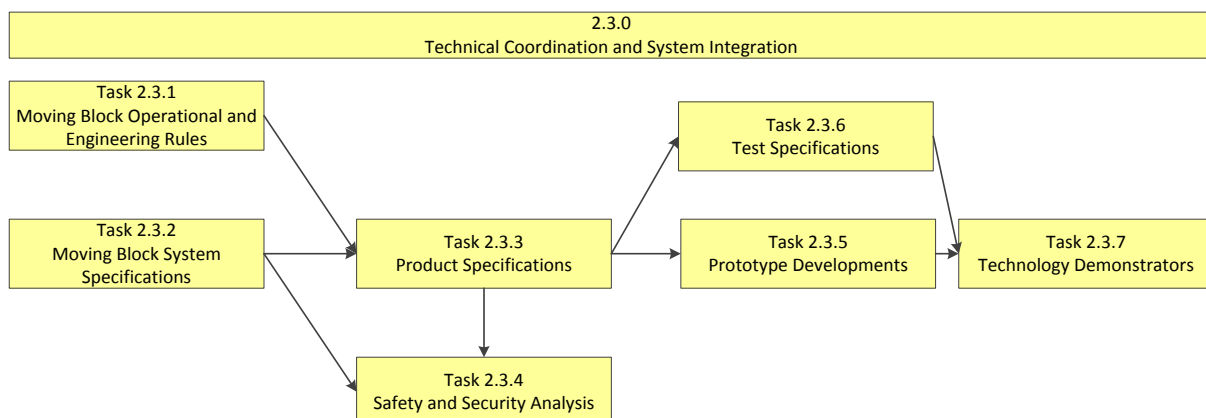



### **Task 2.3.1 Moving Block Operational and Engineering Rules**

The objective of this task is to define the changes required to Operational and Engineering Rules to permit the cost-effective implementation of Moving Block Signalling Systems.

Operational rules are concerned with operational aspects, but it is worth noting that many of these will be associated with exceptions to normal operations. For example, there will need to be rules about how to handle a failed train, for a railway without trackside train detection.

Other examples of areas where new rules will be required are:

- transition into a Moving Block Signalling System area
- the transition out of a Moving Block Signalling System area
- mixed operation of fitted and unfitted trains
- shunting operations within Moving Block Signalling System areas

Engineering rules are concerned with the implementation of Moving Block Signalling Systems. For example, there may be rules associated with where bi-directional signalling is permitted.

The work on Engineering Rules will be important in order to gain maximum benefits from Moving Block signalling, for example:

- performance in bottleneck areas;
- reaching maximum capacity;
- reaching minimum equipment fitted to the infrastructure.

### **Task 2.3.2 Moving Block System Specifications**

This task will take as its starting point the work from EU FP7 project "Next Generation Train Control" (NGTC). The NGTC project includes work on Moving Block Principles, and work on the architecture of signalling systems.

This information will be used to create Application Specifications and Interface Specifications for the different market segments:

- Urban/Suburban
- High Speed Main Line
- Low Traffic and Freight

### **Task 2.3.3 Product Specifications**

The objective of this task is to define the Product Specifications required Moving Block Signalling Systems.



The task will take as its starting point the Application Specifications for the different market segments.

The products will be separated, at minimum, between the trackside and train-carried components of the Moving Block Signalling System, as is currently the case for ETCS.

This task will also determine the additional product requirements relevant to an Overlay Moving Block Signalling System. This part of the work is important to understanding the feasibility of migration to a Moving Block Signalling System, and also the potential for switching between Moving Block and conventional signalling.

#### **Task 2.3.4 Safety and Security Analysis**

The objective of this task is to examine the safety and security of a Moving Block Signalling System.

The largest issue from the safety analysis point of view is the removal of any dependence on trackside train detection. This will require collaboration with IP2 TD2.5 Train Integrity.

This task is expected to make use of Open Calls to enable use of external independent safety experts.

Work on security analysis will require collaboration with IP2 TD2.11 Cybersecurity.

The task will take as its starting point the Application Specifications for the different market segments.

The end objective is to ensure that it will be possible to make a safety case for Moving Block Signalling Systems.

#### **Task 2.3.5 Prototype Developments**

The objective of the prototype developments within this task is to arrive at practical demonstrations of prototype systems, which are ready for laboratory testing within the Moving Block Technical Demonstrators (Task 2.3.7).

The prototype developments will reach TRL 3 to 5.

##### **Low Traffic and Freight Prototype:**

- Delivery of Software Requirements Specification of MB solution identifying the differences between low traffic and freights markets also in accordance with Train Integrity TD2.5 outputs.
- Delivery of Software Architecture Specification: the aim is to define an easy way to be compliant with specific requirements of these market segments.
- Delivery of Software Detail Design related to the common model.
- Delivery of Software Detail Design related to the specific model based on specific requirements of low traffic and freight market segments.



#### Overlay Prototype:

- The development aims primarily at covering objectives “smooth migration and transition to moving block” showing full interoperability between unequipped, L2 and L3 equipped trains, both in terms of level transition and system transition. The TD will demonstrate the introduction of moving block whilst there is a mix of vehicles with different types of onboard.
- Part of the work will be to specify and show a moving block system capable of being overlaid on existing interlocking in such a way that a mix of L0 (unequipped), L2 and L3 equipped trains can operate on the same rail and utilized to its best abilities.
- The prototype will also demonstrate a migration path to remove underlying L0 or L2 interlocking when signals and train detection is no longer needed, once all vehicles are fitted with L3. In Addition the TD will demonstrate border transition to and from L3 to and from levels STM, 1 and 2. An interface to L0/L2 interlocking will be specified and used that allows for movement of unequipped vehicles using colour light signals, L2 equipped vehicles by submitting MA to the L2 registered vehicle according to routes and permission's given by the L2 interlocking and allow L3 registered vehicles to fleet on set routes using moving block. The TD will also show that L2 and L3 trains following an L3 train can both move with moving block and that trains following an unequipped or L2 train will follow in L0/L2 even if it is L3 equipped.

#### Urban/Suburban prototype:

- The objective is to develop a prototype system for Moving Block, applied to the Urban/Suburban market segment.
- This prototype will be developed to a level ready for integration with results from the ATO Technology Demonstrator (TD2).
- The prototype system will also be developed to be ready for integration with results from the Communications Technology Demonstrator (TD1) and Train Integrity Technology Demonstrator (TD5), thus resulting in a prototype system for Moving Block, with ATO to GoA2, GoA3 or GoA4, and using new communications technology.
- The technical system scope of the demonstrator development covers trackside signalling systems and on-board devices, and in addition related trackside traffic management systems.
- The development will include the implementation of a new moving block related functions within the trackside signalling systems, as well as the required safety and fall-back functions.
- The technology to be developed will be targeted at complex, large-scale urban/suburban systems with regular mixed-traffic situations. To run moving block operations in an optimised way, the trackside systems will be developed to enable both moving block operation, and close interaction with trackside and on-board ATO systems.

#### High Speed Line prototype:

- The objective is to develop a prototype system for Moving Block applied to the High Speed Line market segments planning to migrated towards ETCS L3. The demonstrator development covers





trackside signalling systems. The technology to be developed will be targeted at large-scale High Speed Line brown field systems with the objective to migrate to moving block in a most robust way and the least possible re-engineering effort. This includes functions to avoid complex operational procedures in degraded situations. To this end the prototype will be ready for integration with results of the train integrity demonstrator TD2.5 in a trackside signalling system.

#### **Task 2.3.6 Test Specifications**

The objective of this task is to provide Test Specifications for a Moving Block Signalling System, which can be used within the Technology Demonstrators, and possibly beyond.

The task will test the Product Specifications for each market segment, and then derive Test Specifications.

The task will also look at the requirements for the testing itself, such as management of test evidence.

#### **Task 2.3.7 Technology Demonstrators**

The purpose of the TD3 Moving Block Technology Demonstrators is to provide practical laboratory demonstrations of the Moving Block Signalling Systems, across the different market segments.

##### Technology Demonstrator for Low Traffic and Freight Prototype:

- Create laboratory based Technology Demonstrator of MB solution: the aim is to demonstrate an increase of headway without changing the wayside equipment applying the methodology to low traffic and freight market segments taking care of the specific characteristics of them.
- Delivery of the Interface Specification between Track-layout data and demonstrator.
- Delivery of Output Data Specification.

##### Technology Demonstrator for Overlay Prototype:

- Show smooth migration and transition to and from moving block, and mixed traffic operation.

##### Urban/Suburban Technology Demonstrator:

- The objective is to provide a Technology Demonstration of a Moving Block system, with ATO to GoA2, and using new communications technology.
- This system will be tested using data representative of a real Urban/Suburban railway, in collaboration with a Railway Undertaking.
- The Technology Demonstrator will also include testing and demonstration of the necessary engineering data configuration systems.
- This Technology Demonstrator considered an important step towards a new generation of railway control systems, in line with Shift2Rail objectives, and in line with the wishes of Railway Undertakings for future systems.

High Speed Line Technology Demonstrator:

- It is the objective to provide a Technology Demonstration of a Moving Block system which will be tested using data representative of a real High Speed Line. The envisaged test suites will also cover typical operational scenarios in a simulated environment. This Technology Demonstrator is considered an important step to provide evidence for the applicability of the moving block concept for brown field systems thus representing a reliable building block for the evolution of High Speed Line systems.

Railway Undertakings involved in this TD will participate in the provision of test data and the assessment of the Technical Demonstrators.

**2.5.3.6. Planning and budget**

IP	TECHNOLOGY DEMONSTRATOR	TASK	TRL	2016	2017	2018	2019	2020	2021	2022	2023	2024	
IP2	TD2.3 Moving Block	Task 2.3.0 Technical Coordination and System Integration	N/A										
		Task 2.3.1 Moving Block Operational and Engineering Rules	N/A										
		Task 2.3.2 Moving Block System Specifications	N/A										
		Task 2.3.3 Product Specifications	N/A										
		Task 2.3.4 Safety and Security Analysis	N/A										
		Task 2.3.5 Prototype Developments	TRL 3/5										
		Task 2.3.6 Test Specifications	N/A										
		Task 2.3.7 Technology Demonstrators	TRL 3/5										

Estimated budget of the TD (including EU funding and Open Calls): 25.06 M€.

**2.5.4. TD2.4: Fail-Safe Train Positioning (including satellite technology)****2.5.4.1. Concept and Objectives of the Fail-Safe Train Positioning (including satellite technologies)**

The TD Fail-Safe Train Positioning (including satellite technology) is aimed to become an absolute positioning system, significantly reducing the number of the traditional train detection systems. The solution will be based on a safe multi-sensor positioning concept, where GNSS is the preferred technology. The approach taken to apply the GNSS based localisation functionality to ERTMS will guarantee the ERTMS interoperability concept from one side and will allow the introduction of the state-of-the-art technologies in the use of absolute position technologies (e.g. GNSS and different Augmentation Subsystems) and of kinematic sensor technologies (e.g. inertial sensors, gyroscope sensors, MEMS).



The following table summarizes the objectives and related main deliverables of this TD:

**Table 14: Concepts and Objectives**

Objectives	Result	Practical (concrete) Deliverable
Significant reduction of the number of traditional train detection systems (e.g. track circuits), using a multi-sensor positioning concept, where GNSS is the preferred technology. When required, IP communication networks might be <u>explored for supporting</u> innovative signalling systems based on GNSS, virtual balises and no track circuits.	Reduction of material, installation and maintenance costs. Vandalism protection	Specification, development and demonstration on Pilot Lines of the absolute positioning functionality, integrated in the ERTMS framework, in railway environments
Interoperable and safe absolute positioning of the train, mainly obtained applying the GNSS technology to the current ERTMS/ETCS core. To cope with GNSS degraded situations, complementary kinematic sensor technologies will be explored and developed.	Interoperability	Specification, development and demonstration on Pilot Lines of the absolute positioning functionality, integrated in the ERTMS framework, in railway environments
Scalable concept in a way that it also allows the integration of future sensor technologies that are not available today	Up to date technology	Specification, development and demonstration on Pilot Lines of the absolute positioning functionality, integrated in the ERTMS framework, in railway environments
Based on the Public results of the STARS Project (i.e. WP2 – Preparation of campaign, WP3 – Field measurement, data collection, WP4–Data post-processing), complementary test campaigns, both in lab and on field, based on a standard process for GNSS SIS characterisation, aimed at identifying efficient and effective solution for performing track survey, and for building Digital Maps. Such complementary tests in combination with the Public results of STARS will be used to assess the GNSS performances in railways environments	Determination of the actual accuracy and the integrity of the information achievable with the different solutions, when applied in a real railway environment	Report including description of the tests and the results, especially in terms of accuracy, integrity risks associated with the estimated position protection level computed on board, impacts on track discrimination and general impacts on availability and safety during the mission of the train  Guidelines for carrying out GNSS Survey along Tracks (Lines/Stations) Guidelines for Building Digital Track Maps

Objectives	Result	Practical (concrete) Deliverable
<p>Definition of (a) models (suitable for railways environments) describing the local effects on the position accuracy, (b) simulators for supporting LAB and Field Tests, (c) define and develop adequate Test Suite for laboratory tests and field tests.</p> <p>The models will also take into account the Public results of the STARS project.</p>	<p>Efficient and Effective Lab Verification Infrastructure</p>	<p>Requirements and demonstrator of the simulators</p> <p>Public interfaces of the Models and Simulators</p>
<p>Study of different solutions to achieve absolute positioning functionality in railway environment, like single constellation and multi-constellation approaches, GNSS algorithm improvement, mono and multi-frequencies receivers, as well as improvements obtained by using alternative augmentation systems and additional kinematic sensors. Define guidelines for performing GNSS Signal In Space Survey, Track Surveys and the EMC environmental characterisation. Analysis of Local effects and modelling (obstruction, multipath, non-line-of-sight) at RF and observables level including contribution to MOPS error models and using 3D models . Investigation on the use of RTK Method in Railways Applications to build a Ground Truth Reference System.</p> <p>Investigation of Digital Map technologies and related development environments.</p> <p>Conception and Integration of a digital Track Map into ETCS, procedures of safe dynamic updating will be defined and described. The description of possible requirements on the Radio Communication Network for limiting the upload transfer time will also be analysed and provided.</p>	<p>Determination of the accuracy and the integrity of the information achievable with the different solutions.</p> <p>Evaluation of their impacts on the Railways Operations.</p> <p>Determination of the best solution(s) in terms of both costs and performances.</p>	<p>Functional analysis of the impacts of implementation of the different solutions, also in terms of impacts on the satellite receivers, on board architectures, on board availability, on board costs.</p> <p>Impact analysis on the ERTMS enhancements for implementing the best identified solution still guarantying the backward compatibility with existing ERTMS systems</p> <p>Updated report containing conclusions about impacts on accuracy and availability of the best solution(s)</p>

Objectives	Result	Practical (concrete) Deliverable
System certification	Definition of the validation process and related Procedures for the application of the new technology to railway environments (i.e. to ERTMS/ETCS)	Documented certification process

The project execution is split into the following four main phases:

### **Phase 1:**

- Analysis of the State-of-the-Art of the related main European projects such as NGTC and STARS and other emerging related international projects (e.g. solutions adopted in China, USA, Russia). These results will be the inputs for this project. Other R&D Projects that have explored the use of the GNSS technologies and the multi-sensors technologies for severe Industrial Application domains will also be analyzed.

The analysis will include (a) the review of the functional architecture and the hazard analysis carried out in the NGTC context, (b) the review of the results of the test campaign performed in the context of STARS, and (c) the review of the statistical characterisation of the GNSS SIS done in the context of STARS.

Development of the business model which deals with the impact of (a) the introduction of the Virtual Balise Concept, (b) the shifting track equipment to trains e.g. localisation, moving block impact on interlocking etc., and (c) the possible use of efficient Radio Communication Networks IP-Based. In addition, such a Business Model will also propose some possible migration strategies for the introduction of the new Fail Safe Train Position Systems and the shifting of signalling functions from the wayside to the on-board.

- Evaluation of the railway environments through a measurement campaign, if a further complementary test campaign with respect to those done in STARS is required.
- Definition and delivery of the System Requirement Specifications (i.e. functional and not functional requirements) of the Fail-Safe Train Positioning (including satellite technologies) subsystem.
- Definition and delivery of the System Architecture of the Fail-Safe Train Positioning (including satellite technologies) subsystem.
- Execution and delivery of the preliminary Functional Hazard Analysis based on the defined SRS and the System Architecture, addressing as well Cyber Security jamming and spoofing.

### **Phase 2:**

- Analysis of the possible solutions and identifications/descriptions of the pros and cons for each of them.



- Proof of concepts by different complementary approaches, starting from modelling and arriving at the development of early prototypes for anticipating the verification of their main critical properties.
- Analysis of the current Certification Process of localisation systems based on GNSS (e.g. those applied in the avionics application domain) to define / identify the V&V and the Certification Processes to be used for ERTMS solutions based on the new Fail-Safe Train Positioning.

### **Phase 3:**

- Verification in the Laboratories of the developed components of the new Fail-Safe Train Positioning.
- Development of complete Fail-Safe Train Positioning prototypes and their verification in the Laboratories.

### **Phase 4:**

- Installation and commissioning of demonstrators based on the new Fail-Safe Train Positioning on different Pilot Trial Sites, representative of different railways application domains such as low traffic lines, regional lines, and high speed lines.
- Field test campaign based on the current CEN/CENELEC standards and the new defined V&V and Certification Processes.
- Update of the required Project deliverables (e.g. SRS, System Architecture, Functional Hazard Analysis) to take into account the results of the Lab and Field Test campaigns.
- Definition and delivery of the suggestions for enhancing the current ERTMS specifications for the introduction of the new Fail-Safe Train Positioning (including satellite technologies) subsystem, also beyond the concept of virtual balise.

The detailed study logic associated with the project work package breakdown structure and the project Gantt are described in § 0.

#### ***2.5.4.2. Technical ambition of the Fail-Safe Train Positioning (including satellite technologies)***

The TD Fail-Safe Train Positioning (including satellite technology) is aimed to become an absolute positioning system, that allows a significant reduction of the number of the traditional train detection systems, and using a safe multi-sensor positioning concept, where GNSS is the preferred technology. Other solutions, e.g. inertial sensors, radio base localisations are considered as add-ons for fulfilling the scope, provided that their use in railways application domains will be demonstrated. Moreover, the concept is scalable in a way that it also allows the integration of future sensor technologies that are not available today or which have not been used so far for railway applications.

This TD is focused on interoperable and safe absolute positioning of the train, mainly obtained applying the GNSS technology to the current ERTMS/ETCS core, and targeting the significant reduction of all the track side traditional train detection systems (balises, track circuits, axle counters,



...). When required flexible and efficient IP Radio Communication Networks might contribute to reach this objective.

The TD architecture is based as much as possible on the current ERTMS/ETCS architecture, with the addition of new functionalities on board which will be responsible for the train location determination and for the reset of the train confidence interval. These new functionalities will be based on the use of the GNSS technology.

The proposed fail-safe positioning system will be defined with the objective of guaranteeing the backward compatibility with existing ERTMS systems. Therefore any regression to the on board system architecture and new interfaces have to be clearly investigated.

The study phase will start from the “single constellation and mono frequency approach” to arrive at the “multi constellation and multi frequency approach”, used to achieve absolute positioning functionality in railway environments. The activity includes identification of all possible GNSS faults and their quantitative effects on the train localisation, identification and characterisation of the local effects on GNSS SIS and on other sensor technologies, modelling of some local effects for performing FMEA on the train position system, identification of the required mitigations, definition of the functional and not functional requirements of the new Fail-Safe Train Positioning subsystem, definition of the Fail-Safe Train Positioning subsystem architecture, execution of the system functional hazard analysis, theoretical determination of the train confidence interval both in nominal and worst-case conditions, analysis of the characteristics of the satellite receivers and antennas and possible optimisations like algorithm improvement. New GNSS algorithms will be investigated and their integration with Digital Map technologies will also be explored.

Starting from the detailed analysis of the results of the field test campaigns carried out in the STARS project, additional test campaigns will be executed if necessary. The accurate analysis of the results of these test campaign is the basis to assess the impacts of local effects/ environmental conditions (e.g. satellite visibility, multipath and RF interference) on a railway line, since they differ significantly from those in other safety critical applications of GNSS, such as in aviation. The impact analysis will be driven by the ERTMS functions where the new Fail-Safe Train Positioning subsystem can have impact.

If additional field test campaigns with respect to those performed in STARS are required, they will be based on a standard process for GNSS signal coverage and accuracy measurement. As the use of new sensor technologies such Radio-Based position sensors is not investigated in the STARS project, some additional field test campaigns to verify their properties and maturity in the railways application domains. The tests have to demonstrate what performance can be achieved in typical and also difficult environments in an interoperable way. The results of the test campaigns (coming from STARS or from this project) will be analysed in the context of the Fail-Safe Train Positioning requirements and related system architecture, and they will be documented in a report, especially in terms of the estimated maximum position error computed by the Positioning System in accordance with the THR to be guaranteed, general impacts on availability and safety during the mission of the train.

Improvements may be obtained using alternative augmentation systems (e.g. Differential GPS and pseudolites) and/or using additional sensors (e.g. gyros, inertial platforms, accelerometers and speed sensors).

**Interaction with other TDs (of the same IP and/or of the other IPs):**

Interaction expected with IP1 (Rolling Stock) and IP3 (Infrastructure) projects, for the integration of the new module(s) on board and for the trackside technology to support the new functionalities and interfaces.

An interaction with TD1.2 (TCMS) is foreseen in terms of availability of the train positioning information provided to the TCMS.

Interactions are foreseen as well with IP2 topics, such as

- TD2.2, ATO, for possible common solutions for database management
- TD2.5, on board train integrity, for the solutions that implement the satellite technology
- TD2.6, Zero on-site testing, improving efficiency of the laboratory tests
- TD2.7, in the aim of standardisation of engineering and operational rules
- TD2.9, traffic management, again for the operational management of the database
- TD2.8, virtually coupled train sets
- TD2.11, cyber security.

**Ambition.**

European and non-European customers are interested in the application of the ERTMS technology, offering interoperability as a basic concept and the signalling advantages with respect to other existing signalling systems.

On the other hand, market research from UNIFE shows that European and non-European customers would like to apply ERTMS enhanced with some new functionalities. This could make ERTMS more competitive with other systems on the market, but would also offer a number of benefits to existing customers.

One of the new functions proposed as a result of the market research mentioned above, is the fail-safe localisation of the train through satellite navigation systems, which would keep the ERTMS core largely unchanged while significantly reducing the need for traditional train detection systems on the track, with advantages with regard to cost, maintenance and vandalism protection.

Research and specification activities on this subject have been managed inside the UNISIG Satellite Positioning WP, and they are currently on-going in the NGTC project.

One of the tasks of the UNISIG and NGTC working groups is the investigation of the available results coming from previous experiences in the same sector (other projects dealing with satellite positioning in railway environment) or other sectors (e.g. aviation).

Scope and main publicly available outcomes of projects dealing with satellite positioning in railway applications were analysed by the UNISIG group, and further analysis is on-going in NGTC. Generally speaking, technical information publicly available about GNSS system performances in railway



environment is currently not sufficient, and moreover some of the analysed projects seem to aim to applications quite different from ERTMS. In any case, the investigation of possible results coming from other parallel projects will be continuously performed both in NGTC and in Shift2Rail, in order to be aligned with other European initiatives, especially those dealing with Galileo and EGNOS.

Results coming from other sectors, such as aviation and maritime transport, have been taken into account too. Requirements used in the aviation sector have been particularly considered. Unfortunately the results coming from these sectors, especially in terms of accuracy and availability of the positioning information, have a low level of applicability in the railway environment, because of the peculiarities of this environment itself. Actually the typical obstacles that are present in railway environments, such as buildings, hills, canyons and tunnels, emphasize sources of errors that were not relevant for other application domains and so not taken into account in other sectors, and that can have a huge impact on the availability and on the accuracy of the positioning information in the railway environments.

According to this analysis, it is clear that the theoretical and quantitative analysis of the GNSS error contributions, the modelling of the identified solution, the model verification and the test activities foreseen in Shift2Rail, for quantifying the GNSS performances in the railway environment, are a key step for the successful application of this technology for realizing the fail-safe positioning of the train. Especially the specific operational and train movement conditions and circumstances of railways will be addressed. The Mission Profiles will be reviewed for outlining possible updating and new engineering rules might be identified.

The public results of the NGTC and the STARS projects will be used as basis for the requirement analysis and the identification of the solution. The SRS, the System Architecture, and the System Functional Hazard Analysis of the Fail-Safe Train Positioning subsystem integrated into the new generation of ERTMS systems will take those results into account. Laboratory and Field test campaigns will be carried out in accordance with the recommendations provided by NGTC and STARS. The trials site(s) will have to be selected to be representative of the targeted environments.

The main measurable advantage, in areas where satellite positioning is applicable, is represented by the significant reduction of the balises for the position referencing and, in combination with train integrity/ETCS Level 3, of the track side traditional train detection systems (track circuits, axle counters, etc.).

#### ***2.5.4.3. Specific Demonstration activities and contribution to ITDs/SPDs***

Three different demonstrator prototypes with a 6/7 TRL will be developed. In particular:

- the complete SIL 4 system prototype of the new Fail-Safe Train Positioning subsystem integrated with an ERTMS based system in the context of the low cost and freight application domains will be developed. A LDS/Virtual BTM prototype will be based on multi-sensor train positioning system (by applying GNSS technology to the current ERTMS/ETCS core) introducing multi-sensors technologies (e.g. accelerometers, odometry sensors), with the ambition of boosting the quality of train localisation and integrity information. Both prototypes will be installed and validated on the same Trial Site; this Trial Site will be selected during the project among those already partially equipped (e.g. the Sardinia Trial Site) to reduce the manufacturing / installation costs.

- A full SIL 4 prototype for the global positioning system will be developed. It will be targeted for its application on regional low density traffic lines where good satellite coverage could be achieved. An important part of the development will be the definition and implementation of a communication interface between the on-board ETCS/EVC device and the odometry subsystem. This prototype will have a modular design that could allow, if requested, its integration on the on-board EVC system.
- A LDS/Virtual-BTM prototype demonstrator with emphasis on application to all HS/Mainlines, Freight and Regional lines (except Urban/suburban lines) will also be developed. This demonstrator will integrate the achievements of the partners in the area of Digital track map and others.

These demonstrators will be defined and developed integrating components developed by the S2R members. With this integration, the completeness and the correctness of the Interface Control Documents that describe the interfaces among the Fail-Safe Train Positioning subsystem's components will also be verified. In addition, as the installation of equipment on Operation Trial Sites requires the adequate authorisations by the Infrastructure Managers and the Train Operators, the Guidelines for the Installations and the Engineering Rules will also be thus checked by different Infrastructure Managers and Train Operators.

Open calls for the involvement of the Train Operators and Infrastructure Managers have been planned.

Furthermore, system validation and certification activities, even though they are applied for demonstrator purposes, will be carried out by applying the new defined validation processes for the GNSS technologies. Open calls have been foreseen for the involvement of the required Independent Safety Assessors.

#### ***2.5.4.4. Impact of the of the Fail-Safe Train Positioning (including satellite technologies)***

The key advantage of TD2.4 is the application of a new and competitive technology to existing standardized signalling systems; the fail-safe train positioning system developed inside TD2.4 scope of work is mainly obtained applying the GNSS technology, eventually complemented with other sensor technologies to cope with situations where GNSS SIS is temporarily not adequate, to the current ERTMS/ETCS core.

Moreover the application of the GNSS positioning allows an increase in the opportunities of application of ERTMS to those low traffic regional and freight lines that are placed in rural areas, where the reduction of installation and maintenance costs is a key aspect.

Since the fail-safe train positioning system developed inside TD2.4 scope of work will be mainly obtained applying the GNSS technology to the current ERTMS/ETCS core, for sure all the TD2.4 outcomes will be submitted to UNISIG for further processing, especially in terms of recommendations for possible changes to ERTMS SRS and FFFIS specifications. The possible introduction of other sensor technologies into the enhanced version of ERTMS will be evaluated on the basis of the results of adequate field tests and the maturity of the proposed technologies in the railways application domains.

So the TD2.4 will have as a result the contribution to the ERTMS/ETCS standards.

### KPI objectives

The relative weight of the benefits provided by this work on the overall system-level KPIs, for the whole Shift2Rail initiative, are estimated (over a total of 100%) as:

1. Operational reliability (20%): Due to the reduction of the total number of failures, according to the reduced number of physical objects to be applied.
2. Competitiveness (80%): Due to reduced Life Cycle Costs, especially in terms of material, installation, maintenance and vandalism protection.

### Strategic Impacts

The description of the strategic impacts produced by the implementation of the TD results and discoveries is organized along three main aspects:

- the support to the competitiveness of the EU industry,
- the compliance with the EU strategic objectives, and
- the degree of maturity of the solutions envisaged to be realized and put into practice in the railway sector.

This is expected to provide an overview of the effects generated at larger scale by the application of the TD results.

Strategic Aspect	Key Contribution from the TD
Support the competitiveness of the EU industry	<ul style="list-style-type: none"> <li>• Technological leadership supported by a combination of radical innovation (application of the satellite positioning technology to fail-safe signalling systems) and technical standards, setting an effective advantage for the European industry</li> <li>• Tangible benefits for the end user:               <ul style="list-style-type: none"> <li>○ Increase of operational reliability: less failures thanks to the reduction of number of physical objects installed on the line</li> <li>○ LCC reduction, especially in terms of material, installation, maintenance and vandalism protection</li> </ul> </li> </ul>
Compliance with EU objectives	<ul style="list-style-type: none"> <li>• The fail-safe train positioning system developed inside TD2.4 scope of work is mainly obtained applying the GNSS technology to the current ERTMS/ETCS core.</li> </ul>
Degree of maturity of the envisaged solutions	Currently most of the proposed technologies are already taken into account from the NGTC WP7, especially in terms of specification activities and preparation of the test campaigns to be performed inside Shift2Rail scope of work

### 2.5.4.5. Implementation of the work programme

#### Overall Structure of the planned activities

In order to achieve the project objectives, the breakdown of tasks structure is depicted in Figure 51 while the detailed Study Logic that includes all tasks is shown in Figure 52.

**Figure 51: Task Structure Breakdown**

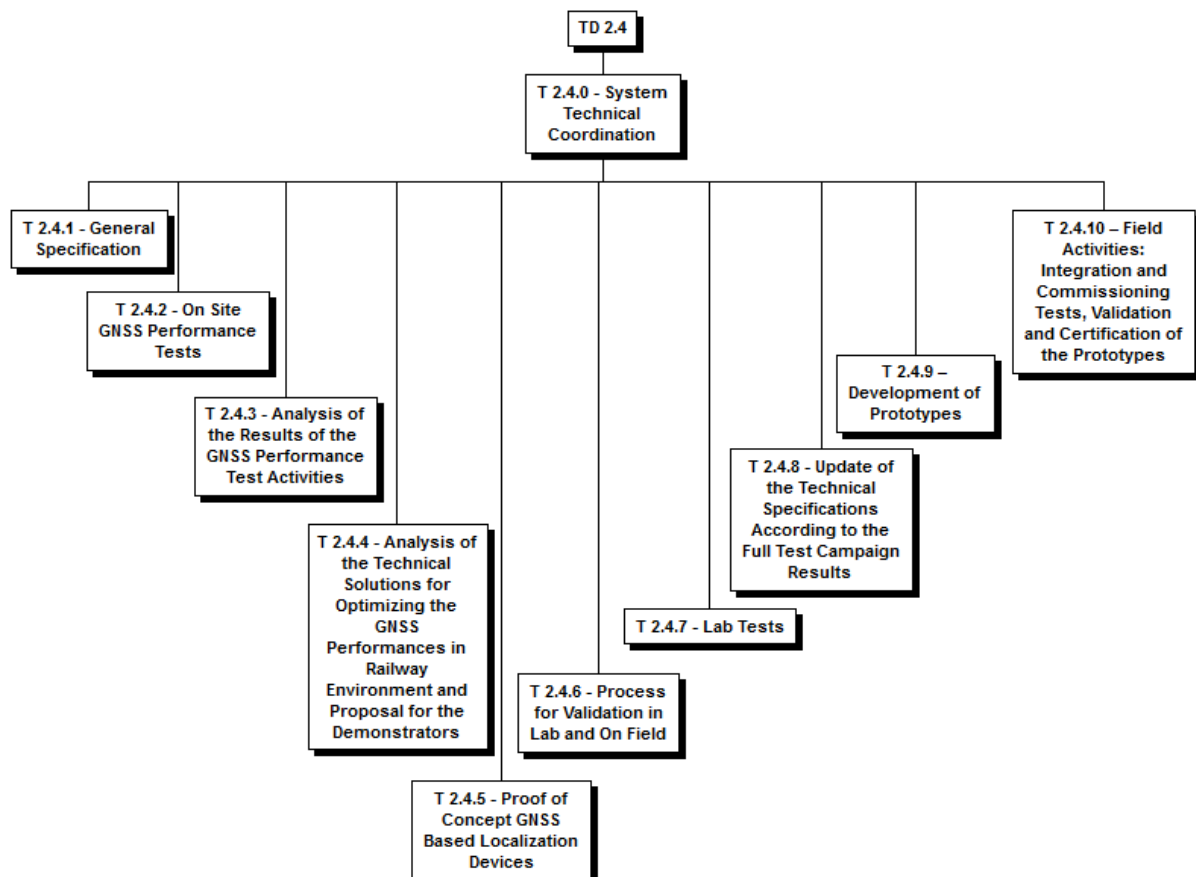
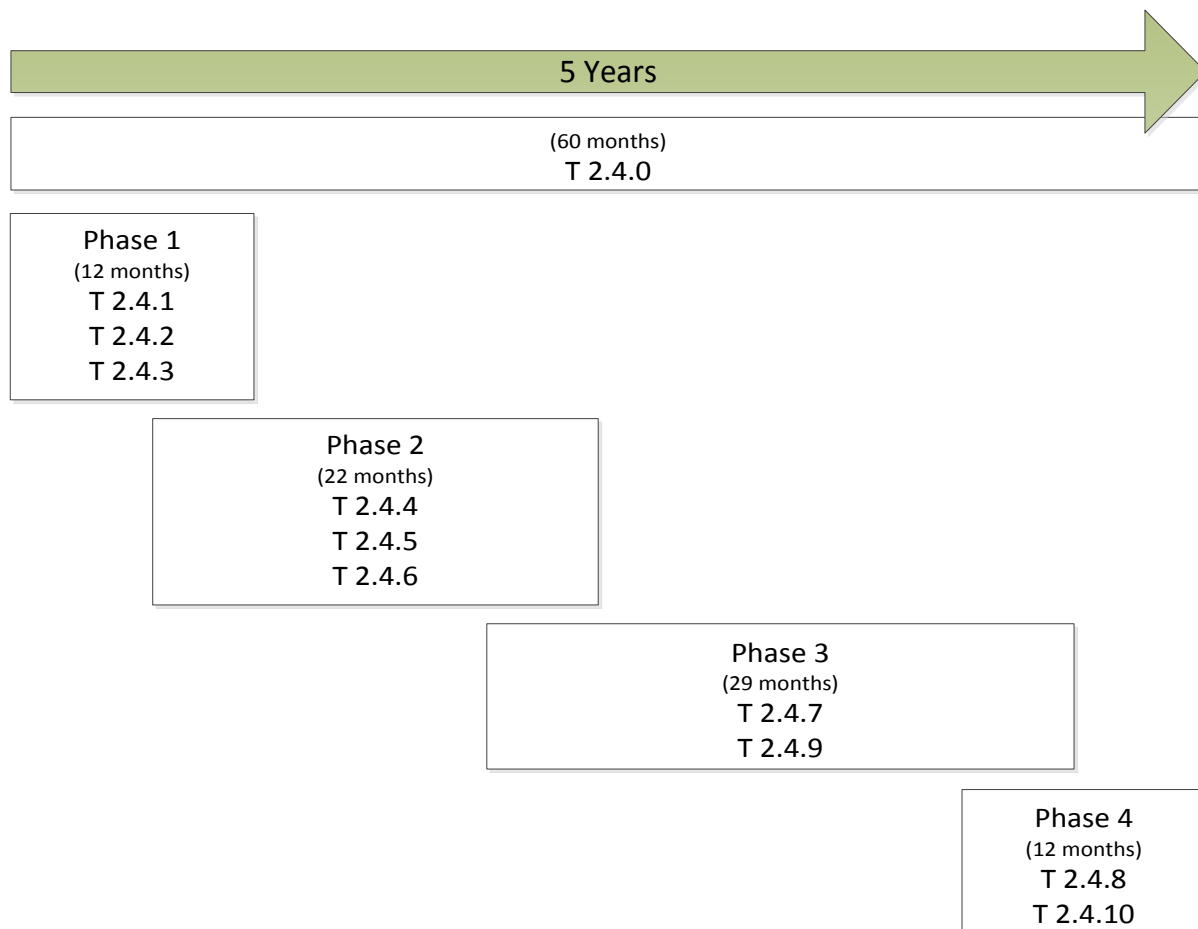

Figure 52: Detailed Study Logic



The work will be performed starting from T 2.4.1 (**the first task of Phase 1**). This task will perform the analysis of the outputs of the main projects such as NGTC and STARS to study/analyze their Public results and also of other R&D Projects that have explored the use of the GNSS technologies and the multi-sensors technologies for severe Industrial Application domains.

Such an analysis will include the review of the functional architecture and of the hazard analysis carried out in the NGTC context, of the technology (e.g. multi kinematic sensors, digital track map) and of the safety analysis techniques used, of the V&V and of the Certification processes adopted.

This task will also define and delivery:

- the System Requirement Specifications (i.e. functional and not functional requirements) of the Fail-Safe Train Positioning (including satellite technologies) subsystem.
- The System Architecture of the Fail-Safe Train Positioning (including satellite technologies) subsystem.

Moreover, in this task, the preliminary Functional Hazard Analysis based on the defined SRS and the System Architecture will be carried out and the related report will be delivered.



For those technologies not explored in STARS and for complement field tests (with respect to those planned in STARS, if necessary), the required additional field test campaigns will be performed in T 2.4.2.

Phase 1 will be completed with T 2.4.3. This task will carry out (a) the review of the results of the test campaign performed in the context of STARS and in T 2.4.2, and (b) the review of the statistical characterisation of the GNSS SIS done in the context of STARS.

At the end of Phase 1, the state-of-the-art of the GNSS technologies and of possible supporting technologies based on kinematic multisensory platforms and radio localisation will be acquired. In addition, the performances achievable with such technologies will be quantified. Finally, the SRS and the System Architecture documents of the new Fail-Safe Train Positioning subsystem will be defined and delivered.

**Phase 2** will start some months before the completion of Phase 1 by means of T 2.4.4. This task will initially use the preliminary versions of the Phase 1 deliverables. It is worth pointing out that some months of overlap introduce no additional project risks with respect to “Finish to Start” approach.

T 2.4.4 will analyze the possible solutions and will provide an accurate description of the pros and cons for each of them. The analysis of the possible solutions will start from solution still based on wayside train detection systems (e.g. track circuits, axel counters) to arrive at solution based on innovative signalling systems without the use of wayside train detection subsystems. In addition, a gradual introduction of the new technology will be applied for keeping the risk under control: mono constellation and mono frequency first and then multi constellation and multi frequencies.

With T 2.4.5, the Proof of concepts will start. Such an important phase will be performed by the combined use of different complementary approaches, starting from modelling and arriving at the development of early prototypes for anticipating the verification of their main critical properties.

Phase 2 will be completed with T 2.4.6. This task will analyze the current Certification Process of localisation systems based on GNSS (e.g. those applied in the avionics application domain) to define / identify the V&V and the Certification Processes to be used for ERTMS solutions based on the new Fail-Safe Train Positioning.

At the end of Phase 2, different possible solutions will be identified and their possible use will be demonstrated. Furthermore, the new processes to be used for performing the V&V and the Certification of new ERTMS systems based on the new Fail-Safe Train Positioning subsystem will be identified and described.

**Phase 3** will mainly cope with (a) the verification in the Laboratories of the developed components of the new Fail-Safe Train Positioning (T 2.4.7) and (b) the development of complete Fail-Safe Train Positioning prototypes and their verification in the Participants’ Laboratories. Phase 3 will have some months of overlaps with Phase 2 to anticipate its completion without introducing additional project risks.

At the end of Phase 3, both the new Fail-Safe Train Position subsystem and the complete demonstrators will be available and operational in the Laboratories of B, D and I.



**Phase 4** will address:

- the installation and commissioning of demonstrators based on the new Fail-Safe Train Positioning on different Pilot Trial Sites, representative of different railways application domains such as low traffic lines, regional lines, and high speed lines (T 2.4.10).
- Field test campaign based on the current CENELEC standards and the new defined V&V and Certification Processes (T 2.4.10).
- Update of the required Project deliverables (e.g. SRS, System Architecture, Functional Hazard Analysis) to take into account the results of the Lab and Field Test campaigns (T 2.4.8).
- Definition and delivery of the suggestions for enhancing the current ERTMS specifications for the introduction of the new Fail-Safe Train Positioning (including satellite technologies) subsystem (T 2.4.8).

At the end of Phase 4, the benefits coming from the use of the new Fail-Safe Train Positioning subsystem in the new generation of ERTMS systems will be qualitatively quantitatively demonstrated: three Trial Sites will be operational with this new solution.

### **Detailed tasks description**

#### **T2.4.1 – General Specification**

##### **Short Task Description:**

Analysis of the results coming from previous European and International projects dealing with satellite positioning in railway environment, in terms of performances, methods, equipment, safety analysis and certification activities.

Analysis of the specifications produced by NGTC working group, especially in terms of functional requirements, architecture analysis, standard methods for GNSS performances measurements and safety analysis.

Analysis of the State-of-Art in radio localisation technologies.

Analysis of the State-of-Art in the Digital Map technologies.

Definition and delivery of the System Requirement Specifications (i.e. functional and not functional requirements) of the Fail-Safe Train Positioning (including satellite technologies) subsystem.

Definition and delivery of the System Architecture of the Fail-Safe Train Positioning (including satellite technologies) subsystem.

Execution and delivery of the preliminary Functional Hazard Analysis based on the defined SRS and the System Architecture.

Development of a Business Model for evaluating the impacts of the introduction of the new technologies and for proposing possible migrations strategies.

**Detailed Task Description:**

The S2R members will:

- contribute to the definition and the delivery of the System Requirement Specifications (i.e. functional and not functional requirements) and of the System Architecture of the Fail-Safe Train Positioning (including satellite technologies) subsystem;
- contribute to the execution and the delivery of the preliminary Functional Hazard Analysis based on the defined SRS and the System Architecture;
- Analyse R&D projects where the GNSS technologies are used for safe critical localisation. In addition, the RTCA standards and their planned evolutions will be analysed to identify and to evaluate processes / methodologies / algorithms / recommendations applicable to railways application domains;
- Assess existing functional, safety, performance and system requirements will be assessed, taking into account GRAIL-2, NGTC WP7 and STARS projects as well as SafeLOC and RegioSAT from which a deep understanding of GNSS safety integrity and availability aspects is derived.
- Analyze the results obtained in other projects and compare such results with the solutions for the definition of new algorithms and methods for defining safe position of a train along the tracks. This solution will be based on the use of commercial receivers with the adoption of proprietary software algorithms that make the acquisition of the data and their use suitable for railway applications.

**T2.4.2 – On site GNSS performance tests****Short Task Description:**

This task will complement the field test campaigns that will be executed in the context of the STARS project, whose kick-off is planned in February 2016.

In particular, for those technologies not explored in STARS and for checking some GNSS SIS characteristics not totally covered in STARS (if necessary), this task will execute the additional required field performances tests or will use the datasets coming from other projects (e.g. ERSAT-EAV) for assessing the new technology in railway environments.

The field tests will be performed according to the standard process for GNSS signal coverage and the measurement process defined in STARS.

**Detailed Task Description:**

The S2R members will:

- define and develop guidelines for performing Signal In Space Survey and identifying environmental constraints that have impact on SIS quality. Moreover, adequate procedures to be used for carrying out such guidelines will be defined and verified. Field Tests will also be executed on the train where a DETECTOR to perform a comparative analysis of different technologies and the B RF Survey Guidelines will be installed;



- perform on site GNSS (GPS/Galileo+EGNOS) performances tests in a railway environment, including definition of tests scenarios with respect to a Generic Safety Case;
- contribute to the execution of tests in the field to define the performance of the system. If available, field tests might be executed by also using micro satellites.
- Install DETECTOR device(s) on vehicles and at static sites (at the side of the railway track) to collect Radio Frequency Interference (RFI) events. It is proposed to use vehicles and test sites in at least two member states in order to capture as wide a range of threats as possible. The threats will be analysed within the context of a separate T2.4.3 activity. Carrying out the comparative analysis about the detected threats with different approaches is also planned.

### **T2.4.3 – Analysis of the results of the GNSS Performance test activities**

#### **Short Task Description:**

Detailed analysis of the measured GNSS performances in railway environment or of the performance results coming from other Projects (e.g. STARS), and analysis of their impacts on the Fail-Safe Train Positioning subsystem defined in T 2.4.1.

Detailed analysis of (a) the measured field test results about radio localisation sensors / equipment in severe industrial environments and/or (b) of the field test results coming from other Projects to evaluate the use of radio localisation technologies in railways environments. Such technologies are expected to be used as a complementary localisation input channels when the GNSS signal quality is poor, provided that their technology maturity is demonstrated for railways applications.

To avoid the multiple developments of Performance analysis tools, the best existing tools among the Participants will be identified and the strategy for sharing the output of these developments among the participants will be evaluated.

#### **Detailed Task Description:**

The S2R members will:

- analyse the GNSS SIS recorded with the Survey in Task 2.4.2 and with STARS (a) to enhance the characterisation of the statistical properties of the RF signals derived from the STARS project, if necessary, (b) to populate the RF signal database generated with the ERSAT-EAV project with additional representative recorded RF signals, (c) to analyse the type of RFI threats obtained in T 2.4.2 with the Detector with the objective of developing analytic models, and (e) to evaluate the impact of detected EMI on the system performance defined in T2.4.1. Adequate test scenario will be executed by using the recorded GNSS SIS. The statistical characterisation of the recorded RF signals will allow the quantitative definition of the possible contributions to the protection level error budget; such a protection level is estimated on board and it is associated with the virtual balise location accuracy. The output of these activities will be used for building the MatLab / Simulink Models and the related test infrastructure in the appropriate TD 2.4 tasks. Moreover, in order to cope with areas where GNSS signal might have a poor quality as well as the high demanding requirement to reach a SIL 4 Train Positioning system, the analysis will also evaluate



the benefits obtainable by the combined use of the existing on board SIL 4 odometry with the on board GNSS PVT. Finally, specific KPI for performing a quantitative assessment of the performance of the components of the Fail-Safe Train Positioning subsystem will also be defined.

The definition of the Model of the detected RFI threats will be done. Moreover, the input and the output interfaces will be defined for public use and possibly suitable for the use of such a Model implementation in different Test Infrastructures.

Finally, to speed up the analysis of field data that will be later collected in T 2.4.10, auxiliary supporting tool will be specified and the development shared with the S2R members.

- participate to the analysis of GNSS performance and impact on characteristics of satellite receivers;
- determine current GNSS performances in railway environment and analysis of their impacts on the technical specifications for GNSS positioning in railway environment;
- perform the onsite tests including definition of tests scenarios and analysis of results;
- analyse field test activity results; analysis will be mostly focused on environment impact (satellite visibility/signal attenuation and blocking, multipath effect, RF interference, etc.) with respect to Virtual Balise performance;
- consolidate the data results coming from the test campaign;
- Analyse RFI data captured within Task 2.4.2 or with STARS and characterise the types of interference threats encountered in order to create a novel and unique database of RFI threats in the railway environment. This will allow the different threats to be modelled, providing an input to the threat analysis in T2.4.4 and the simulation suite that is to be built in T2.4.5;
- Analyze local effects and perform modelling at RF and observables level incl. contribution to MOPS error models and using 3D models. This activity will rely on access to the data collected in T2.4.2 and STARS for the development of a detailed understanding of the impact of local effects on GNSS (GALILEO, GPS etc.) and augmentation (EGNOS, DGNSS, AGNSS etc.) signals. A local environmental model is required that can be tailored to represent a range of different operational railway environments. This will ensure that future GNSS simulation work can utilize local models to condition GNSS signals to account for obstruction, multipath and non-line-of-sight effects. This is needed for radio frequency simulations and raw data generation (observables). A key output of this activity will be to propose performance models in typical environments as an input to the development of Minimum Operational Performance Standards (MOPS);
- Modify and use comprehensive Performance Analysis Tool, including KPI. A performance analysis tool is required that is able to provide a consistent and comprehensive assessment of the performance of different LDS solutions with respect to Key Performance Indicators (KPIs) and agreed metrics. The output tool from this activity will be made available to other TD2.4 activities.



#### **T2.4.4 – Analysis of the technical solutions for optimizing the GNSS performances in railway environment and proposal for the demonstrators**

##### **Short Task Description:**

Analysis of the technical solutions, eventually also based on the use of multi sensor solutions, for optimizing the GNSS performances in railway environment and proposal for the demonstrators

Analysis of the possibilities of the single and multi-constellation approach to achieve absolute positioning functionality in railway environment.

The task includes the theoretical determination of the confidence interval, analysis of the required characteristics of the satellite receivers and possible optimisations.

##### **Detailed Task Description:**

The S2R members will:

- analyse the impacts on the system performance defined in T 2.4.1 of the main properties of the GNSS SIS recorded during the survey in T 2.4.2 and in STARS along with the GNSS Faults Model. The output of the failure mode and effects analysis will lead to different possible alternative solution. The identification of the best solution will be carried out by using adequate Decision, Analysis, and Resolution methods. In particular, the following main activities will be carried out:
  - Investigation of innovative GNSS algorithms based on the tight coupling with very accurate Digital Map and suitable for coping with the threats identified in T2.4.3; the investigation will take into account the mitigations coming from the ERTMS intrinsic application conditions and the ERTMS functions where the use of Virtual Balise has impact.
  - Analysis of possible Measures to navigate the Digital Map when the GNSS signal might have a poor quality;
  - Investigation on the best algorithms to generate Virtual Balise compliant with the ERTMS hazards associated with the physical balises (e.g. cross talk, sequence of balises inside the same Balise Group, sequence of balises groups); an incremental approach will be used starting from the applications where wayside train detection subsystems are available to arrive at the applications without track circuits / axel counters.
  - Analysis of the best data fusion algorithms to overcome areas where GNSS Signal has a poor quality based on the on board SIL 4 odometry. Note that, in general, the SIL 4 Odometry is composed of a kinematic multisensor architecture. The collaboration with other participants on a multi sensors approach will lead to the identification of possible innovative SIL 4 odometry subsystem;
  - Analysis of the properties of on Board Antennas to cope with multipath local phenomena;
  - Identification and analysis of the Fault and Failure Models of the complete GNSS chain to allow the execution of FMEA and the related System Hazard Analysis (at the ERTMS system level).



- analyze technical solutions and proposal of architecture for a demonstrator suitable for Safety Critical applications.
- analyze the technical solutions for optimizing the GNSS performances in railway environment and provide a proposal for the demonstrators.
- elaborate on a Generic Safety Case as base for later validation and the required/accepted analysis methods and tools.
- focus on multi-constellation and multi-frequency approach supported by SBAS (EGNOS); the first experiments with "open PVT" will be undertaken here. In addition, they will investigate and will propose some methods for selecting suitable track segments/locations for Virtual Balises and estimate their performance;
- define an open concept for the demonstrator definition. Obtaining a unique approach is the goal.
- design algorithms for:
  - use of communications signals to enhance continuity of positioning (Wireless Communications Technology e.g. GSM, LTE, plus Ultra Wideband). An additional sensor to the GNSS positioning system based on wireless communication technologies is proposed. The signals to be employed for positioning will be transmitted by the infrastructure manager or the public mobile network. This is especially useful for cities, where in urban canyons GNSS signals are blocked and a number of wireless communication technologies are available. A capability for including wireless communications technology positioning within a GNSS-based solution for ETCS Level 3 is currently being developed in the EC EATS project In tandem to this the potential for use of Ultra Wideband (UWB) signals to improve the continuity of positioning within tunnels will be analysed.
  - use of Digital Route Maps and low-cost Dead Reckoning sensors for PVT enhancement, in particular integrity. The integrity and continuity of an LDS solution may be enhanced through the use of a DRM and low-cost dead-reckoning onboard the train. This may provide an alternative to expensive inertial systems. Different possible approaches for using DRM will be analysed. Some of these have a particular benefit for integrity, while also enabling a 3D solution to be calculated with only two GNSS satellites. It is advantageous to Map-Aiding for the geospatial track component of a DRM to include the vertical dimension (3D). It will link to the Map-Aiding solution to TRL5 (offline processing of real data), currently developed within the UK Map3 project, which includes novel integrity algorithms (fault detection and exclusion, and protection level calculation). Sources of information which may be utilised for dead-reckoning include low-cost inertial sensors e.g. single axis gyroscope, odometry and cab signals e.g. train orientation. Dead reckoning techniques may be combined with Map-Aiding algorithms through filtering techniques, and this increases the scope for increasing the robustness of fault detection and exclusion algorithms.
  - PVT robustness to RFI for on-train position system and track-side GNSS reference stations. Methods will be proposed and designed to improve the robustness of the use of GNSS and other wireless communications technologies within the railway to RFI threats. This will be based on those threats identified in T2.4.3, several of which may be unique to the railway

environment. It will consider mitigation methods for an on-train LDS as well as track-side reference stations used as part of an augmentation solution.

- Provide input to dedicated ETCS GNSS Antenna-Receiver definition. The characteristics of the GNSS hardware required for application in an ETCS context is currently an open point. It is anticipated that transparent GNSS receiver properties are required that can be certified as recommended in railways application domains. Detailed hardware and software design specifications should be produced including acquisition and tracking modes and dynamic models to be used as Informative Documents. Various techniques to ensure that design errors and intermittent failures cannot cause a hazard will be described.
- Provide input to FMEA through GNSS Rx chain analysis. Work is proposed to produce an overarching Failure Modes and Effects Analysis (FMEA) covering the use of GNSS signals and augmentation services within ERTMS. At a high level this will examine the failure modes at the system, signal propagation, local effects and receiver levels including the full RF chain. This will provide input to an overall FMEA for an LDS system.
- Provide input to threat model based on identified RFI threats. A threat model should be developed that describes interference, jamming, spoofing and meaconing threats based on real observed events. The analysis, characterisation and modelling of captured RFI data within T2.4.3 will enable the development of a detailed understanding of the threat picture with regards GNSS and other wireless signals within the rail environment. On this basis it is proposed to provide an input to an overall threat model. This will include core GNSS (GALILEO, GPS, etc.) and augmentation services (EGNOS, DGNSS, AGNSS etc.). Testing of these threats should be undertaken on GNSS receivers to assess levels of degradation and denial and informing the development of more robust and resilient solutions for GNSS based locators within ERTMS architecture.

#### **T2.4.5 – Proof of concept GNSS based localisation devices**

##### **Short Task Description:**

This activity refers to the development/selection/preparation of the GNSS based localisation devices answering to interoperability requirements defined in the previous tasks.

This is the equipment that will be used for the following laboratory tests and that will be the basis for the development of the full prototype.

##### **Detailed Task Description:**

The S2R members will:

- identify the main system components to which main risks (e.g. technological, schedule, testability, ...) are associated. For such components, the development of early prototypes will be done so as to anticipate the verification of their main properties (i.e. functional and not functional requirements) with the objective to reduce the risks. Example of proposed verification techniques are Modelling in MatLab / Simulink some critical components of the LDS system (e.g. GNSS algorithms, multipath phenomena), Tests verification on host environment first and then



on target. Such prototypes will be verified by using the Test Infrastructure developed. Test scenario based on the use of simulated and real components will be used. In particular, the following activities will be performed:

- The identified GNSS algorithms, integrated with real Digital Map (e.g. that associated with the Sardinia Trial Site) will be verified by using existing real and simulated datasets coming from other project such ERSAT-EAV and STARS and from open calls.
- Specific Verification Tests will be executed on the GNSS Algorithms by injecting the identified threats so as to evaluate their robustness and the impact on simulated train runs; KPIs related to the intrusiveness on board runs will be collected; Test specifications and the related test procedures can be developed in collaboration with interested participants from open calls;
- Enhancement of the existing ERTMS Test Infrastructure for including the additional simulation tools to cope with GNSS technologies and the Digital Maps. In addition, the Test Infrastructure will also be enhanced for including simulated components only, target components only and a missed scenario.
- develop the specification of the test environment and tests specifications for the proof of concept.;
- Develop, select and prepare proof of concept of GNSS based localisation devices and of the simulators and tools for the laboratory tests;
- Revise and further develop the Generic Safety Case, as base for later validation and the required/accepted analysis methods and tools;
- Develop functional samples of the future LDS/Virtual-BTM prototype; substantial effort in terms of software and hardware implementation. First attempts to verify feasibility to achieve the required performance will be carried out;
- Define all requirements for the detailed definition of the final product. In this task each hardware component of the system will be defined;
- develop algorithms and simulators:
  - Algorithm development and verification: use of communications signals to enhance continuity of positioning (Wireless Communications Technology e.g. GSM, LTE, plus Ultra Wideband). The algorithms designed in T2.4.4 for integrating positioning based on wireless communications technologies and Ultra Wideband signals within a GNSS-based LDS will be further developed and verified using existing real and simulated datasets.
  - Algorithm development and verification: use of Digital Route Maps and low-cost Dead Reckoning sensors for PVT enhancement, in particular integrity. The algorithms designed in T2.4.4 for integrating a DRM (Map-Matching, Map-Aiding) and dead reckoning techniques with an LDS will be further developed and verified using existing real and simulated datasets including a sample geospatial track model to represent a DRM.



- Algorithm development and verification: PVT robustness of to RFI for on-train position system and track-side GNSS reference stations. The algorithms designed in T2.4.4 for enhancing LDS robustness will be further developed and verified using existing real and simulated datasets.
- Development of Simulation suite for validation (including Raw Data Generation, RF generation, Monte Carlo, integration within ETCS reference model). This activity will develop a flexible simulation platform for on-train position systems in an ETCS environment. It will include Raw Data Generation, RF generation and Monte Carlo simulation capabilities for GNSS and other systems/sensors e.g. wireless communications technologies. The modelling of local effects and RFI threats in T2.4.3 will feed into this activity. A 3D environment modelling function will be developed on which to condition simulated signals, being flexible in order to offer both generic and real railway environment modelling. The platform will allow the integration of a position system with an ETCS reference model to be tested.
- GNSS Rx channel modelling for validation activities. GNSS performances strongly depend on the environment of propagation. In particular for safety applications, the understanding of GNSS behaviour is needed in order to propose a solution capable of answering the requirements. The models will characterise the GNSS receiver behaviour of the railway environment. Channel models will provide information on the quality of reception in railway environments, with information on attenuation but also pseudo-range delays and positioning errors (that suppose to be able to process several channels). The output of this activity will feed into the validation work in T2.4.6.
- Development of Digital Route Map as part of LDS. This work will be performed by DLR. Developments will focus very much on the lifecycle aspects of the DRM considering the safety/security constraints.

#### **T2.4.6 – Process for validation in lab and on field**

##### **Short Task Description:**

Definition of the process for the validation/certification activities in laboratory and on field (including test plans)

The activity foresees open calls for the involvement of experts in validation activities, coming both from railway and from satellite fields of application. In addition, cooperation with an independent safety assessor (ISA) will be established (either as an open call or as a subcontract).

##### **Detailed Task Description:**

The S2R members will:

- prepare the specifications for the validation/certification;
- define the validation/certification process. In particular, as the current CENELEC Standards and the ERTMS specification subsets do not cover the use of GNSS technologies in the railways application domains, there will be a need to adapt the definition and to the development of the MOPS to be used for certified the use of GNSS technologies in railways domains; an analogous



approach used in avionics (e.g. RTCA) will be proposed. Finally, as far as the Digital Map is concerned, as it is a component that contributes to the SIL 4 requirement, the definition of the processes (a) to carry out the track survey, (b) to build the Digital Map, and (c) to validate the Digital Map as a generic component will be proposed.;

- involve safety and validation experts to support these activities; and develop cooperation with an independent safety assessor;
- support the optimisation of testing and the implementation of tests in the laboratory by providing platforms for the execution of the tests.

#### **T2.4.7 – Lab tests**

##### **Short Task Description:**

Laboratory tests task: the Lab test will be performed using the GNSS based localisation devices and the simulators defined in the dedicated tasks and applying the process for the validation in lab defined in the dedicated task as well.

The solutions developed and verified in previous tasks (e.g. T2.4.5) will be tested in a laboratory environment. This will involve use of the simulation suite developed in T2.4.5.

##### **Detailed Task Description:**

The S2R members will:

- perform Lab tests by using the Test Infrastructure Prototype, defined in previous tasks, for simulating different GNSS environmental scenarios. Previous defined Tests Suite will be enhanced, if necessary, for carrying out functional and not functional tests. In particular, starting from scenario recorder on the field (e.g. Sardinia Trial Site or coming from other Projects, STARS), specific fault injections will be defined and used to re-create the abnormal situations detected on the field or coming from theoretical analysis. The introduction of GNSS technologies and other sensors exacerbates the complexity of Verification Infrastructure: many events must be **coherently** managed (e.g. synchronisation of ERTMS events with GNSS messages);
- execute performance tests of a functional prototype (TRL3) of Odometer incl. Satellite Positioning and Inertial Sensor;
- verify / adjust the Generic Safety Case according to the achieved lab test results;
- focus on lab tests of "open PVT" algorithm (both PVT estimation itself and corresponding protection level/confidence interval estimation are subjects of the tests); both real and artificial data will be used as PVT inputs; several variants of open PVT algorithm will be tested (differentiated via an extent of other inputs data fusion, e.g. incorporation of inertial or autonomous sensors, localisation support with wireless network, etc.). Model and simulator development is planned, followed by integration and test bed preparation. The model and simulator based in-lab functional verification is anticipated leading to specification of test procedures and scenarios;





- contribute to the execution of laboratory test using specific platforms for the execution of the tests and will support the analysis of results;
- perform a simulation of the micro satellites presence in order to evaluate their influences, provide cooperation to perform test, test platform management and test analysis;
- Perform the following lab testing:
  - Lab testing to achieve TRL4: use of communications signals to enhance continuity of positioning (Wireless Communications Technology e.g. GSM, LTE, plus Ultra Wide Band).
  - Lab testing to achieve TRL4: use of Digital Route Maps and low-cost Dead Reckoning sensors for PVT enhancement, in particular integrity.
  - Lab testing to achieve TRL4: PVT robustness of to RFI for on-train position system and track-side GNSS reference stations.
  - Running of simulation suite for contribution to validation activities (including Raw Data Generation, RF generation, Monte Carlo, integration within ETCS reference model).
  - Lab tests of the Digital Route Map.

#### **T2.4.8 – Update of the technical specifications according to the full test campaign results**

##### **Short Task Description:**

This task includes the update of the technical specifications (e.g. SRS, System Architecture, System Functional Hazard Analysis) due to the results of all tests and validation processes. Recommendations for possible changes to ERTMS SRS and FFFIS specifications will be submitted to UNISIG for further processing.

##### **Detailed Task Description:**

The S2R members will:

- deliver feedback of the test results on the technical specifications and to provide recommendations for the enhancements of ERTMS specifications or for future changes at the ERTMS ETCS SRS;
- deliver feedback of the test results and the implications of the Generic Safety Case on the technical specifications.

#### **T2.4.9 – Development of Prototypes**

##### **Short Task Description:**

Development of a prototype based on integration of different architectures/technologies (e.g. Satellite constellations, ground augmentation systems, on board devices – odometer, inertial platform), model development, and a testing tool for simulating different environment scenarios (e.g. tunnels, canyons, severe weather conditions).



Define the Demonstrator architectures to be installed in T 2.4.10 and identify the corresponding Bill Of Materials.

Launch the required productions so as to have the platforms on time for T 2.4.10.

#### **Detailed Task Description:**

The S2R members will:

- design and develop a SIL4 system prototype composed of an ERTMS Based System integrated with the GNSS Localisation Determination System that will implement the Virtual Balise concepts and will use enhanced version of GBAS or SBAS Augmentation Systems. GNSS Localisation will start with Mono-constellations technologies and then will be enhanced with Multi-constellations technologies. Specific emphasis will be put on the identification of the Antenna's technology and the GNSS algorithms to cope with multipath in the Railways Application Domain. Accurate analysis will be carried out on the design and the management of the on Board Track database to guarantee (a) high and predictable performance and (b) safe updating of the on board database in terms of virtual balises without impacting the train service. For limiting / avoiding impact on the Operation Rules of Railways Train Managers and on Railways Infrastructure Managers, particular attentions will be placed on measures to allow the updating of the Digital Track Map via the Signalling Radio Network by using ERTMS packets or extension of ERTMS packets (if required). The main objective is to update /upload the on board Digital Map during the normal train operation (e.g. at SOM or via packets during the train run). **Innovative signalling functions** based on satellite locations (defined and analysed in previous tasks) to prevent train collision will be developed and verified; such innovative functions will not be based on track circuit or other wayside train detection equipment. The guidelines for carrying out the wayside and on board surveys with respect to EMC, Signal In Space quality, digital map needs will be tailored. B prototype will be tailored for the low cost and freight application domains with a 6/7 TRL;
- develop a full prototype for the global positioning system according to the proof of concept and demonstrator proposals agreed on the previous phases. The prototype will be SIL4 compliant, as defined in EN5016, EN5018 and EN50129 railway standards. However, its modular architecture and implementation can be instantiated to meet less demanding SIL requirements. The different cost benefits analysis will also be outlined. In principle, the prototype will be developed as an independent odometry subsystem supplying, among others, the following outputs; speed of the train, distance covered by the train, absolute position of the train (in global geodetic coordinates), as well as the confidence interval. The preferred technology for global positioning is GNSS (GPS/Galileo/ EGNOS), but other sensors, such as inertial sensors and wheel speed sensors will be necessary in order to increase the system's availability and reach the requested integrity level. One of the main goals will be the design and development of a multisensor fusion algorithm. As a previous step, a study of the state of the art of the existing multi-sensor data fusion algorithms will be carried out (Kalman filtering, Bayesian inference, fuzzy logic ...);

This prototype will be targeted for its application on regional low density traffic lines where good satellite coverage could be achieved. An important part of the development will be the definition and implementation of a communication interface between the on-board ETCS/EVC device and the odometry subsystem. The new odometry subsystem will supply the EVC with global position



and speed information, and will receive balise information, as input from the EVC. It is expected that a balise reader with a minimum set of balises will be necessary in order to confirm the train's position on a certain track section, and to discriminate between positions on parallel tracks. The concept of virtual balises will be implemented as an additional output of the positioning system. In that case, a digital map must be handled by the positioning system and shared with the EVC. In that case, the best solution would be to extend the ERTMS-Euroradio communication in order to dynamically receive, from RBCs, the balise global positions together with the rest of balise data, both for real and virtual balises;

This prototype is targeted to reach TRL 6/7 and will have a modular design that could allow, if requested, its integration on the on-board EVC system. This decision will depend on the architectural design agreed on previous phases of the project;

- develop an Odometer which integrates within the speed and distance determination process input data from wheel sensors, GPS and inertial platforms allowing in a further step to integrate new technologies such as eddy-current sensors suitable for odometer and/or track inspection purposes;
- develop a HSL/Main Line prototype global positioning system sensor comprising sensor fusion – as well covering sensors being present on the trains already as well as potentially additional sensors being used in non-railway environments such as airplane landing support systems, augmentation systems – space based or ground based (depending on previous analysis and assessment of implementation risk and effort), advanced signal processing capabilities – extending today's capabilities of odometry, and additional RBC interaction – effectively using radio communication to support reset of position confidence levels, if useful/required. This prototype will reach a TRL of 4-5. However, a special focus will be put on the Generic Safety Case which will be verified according to the achieved development test results;
- implement its own LDS/Virtual-BTM prototype demonstrator with emphasis on application to all HS/Mainlines, Freight and Regional lines (except Urban/suburban lines) and undertake its laboratory testing; the demonstrator will integrate the achievements of the partners in the area of Digital track map and others;
- develop a prototype based on the specifications and features described in previous tasks. It will be a SIL4 system suitable for application in all lines. The prototype will be based on ERTMS On board system with an additional LDS /virtual BTM system. The prototype will be able to work with micro and small satellite constellations. The objective of this prototype is also the reduction of overall costs of an ERTMS solution, in particular by enabling a significant reduction in all track-side conventional train detection systems (balises, track circuits, axle counters, etc.). The concept will be scalable and allow for the integration of future sensor technologies;
- carry out the following activities:
  - Provision of verified algorithms to prototype(s) with target of TRL5/6: use of communications signals to enhance continuity of positioning (Wireless Communications Technology e.g. GSM, LTE, plus Ultra Wide Band). It is proposed that the algorithms tested in T2.4.7 for integrating

positioning based on wireless communications technologies and Ultra Wideband signals within a GNSS-based LDS are integrated within one or more of the prototypes.

- Provision of verified algorithms to prototype(s) with target of TRL5/6: use of Digital Route Maps and low-cost Dead Reckoning sensors for PVT enhancement, in particular integrity. It is proposed that the algorithms tested in T2.4.7 for integrating a DRM (Map-Matching, Map-Aiding) and dead reckoning techniques with an LDS are integrated within one or more of the prototypes.
- Provision of verified algorithms to prototype(s) with target of TRL5/6: PVT robustness of to RFI for on-train position system and track-side GNSS reference stations. It is proposed that the algorithms tested in T2.4.7 for enhancing LDS robustness are integrated within one or more of the prototypes.

#### **T2.4.10 – Field activities: integration and commissioning tests, validation and certification of the prototypes**

##### **Short Task Description:**

This activity foresees that the prototypes developed according to the previous task are installed on a vehicle, and integrated in a standard ETCS equipment. In order to obtain the required authorisations for the platform installations, adequate Open Calls must be anticipated for the involvement of required Train Operators and Infrastructure Managers.

Preparation and delivery of the documents required for the demonstrators installations.

The integration of the prototypes will be realized on the different system demonstrators, according to the targeted application.

Furthermore static and dynamic tests in the lab and on the track are performed to the prototype developed and integrated.

System validation and certification activities, as far as necessary for demonstrator purposes according to the defined validation process, will be performed on different demonstrators.

Open call activities are foreseen for the support in the execution of the tests and the evaluation of the tests results by satellite technology experts.

Open call is foreseen for the involvement of an Independent Safety Assessor.

##### **Detailed Task Description:**

The S2R members will:

- define, model and develop the Test Infrastructure to verify the developed Prototype. A combined use of different verification methods and technologies will be identified and used; for example, GNSS algorithms will be modelled in MathLab and Simulink, the correctness and the completeness of the quantitative error budget assigned to GNSS error contributions will be verified by means of specific fault injections methods.

In addition, the Test Suites suitable for carrying out tests both at system and subsystem levels will be defined and developed. The Test Infrastructure will be designed and developed to also support the off line reply of Field Log file. Particular attention will be assigned to the facilities for (a) defining and maintaining test scenarios and (b) synchronizing GNSS events with signalling events. Furthermore, the Test Infrastructure will be also designed to allow the automatic execution of tests.

The demonstrator will be operated in a real railway environment and then this operation will be evaluated, validated and documented; the operation of the prototype will be performed and validated in a Pilot /Trial Site (possibly one of the already partially equipped and used for other Projects; one example is the Sardinia Trial Site).

The involvement of respectively the Infrastructure and the Train Managers as well as an independent safety assessor (ISA) in this task are envisaged via open calls.

- carry out a complete set of tests in order to validate and certificate the full developed prototype. Most part of the tests will be carried out on laboratory, but field tests will be also considered.
- develop a validation environment to test and validate the prototype. This validation environment will reproduce the scenarios of the test campaigns, and additionally will reproduce new railway itineraries, in order to create scenarios and situations not covered by the test campaigns but that must be carried out in order to validate the full set of requirements. The validation environment will offer the possibility to introduce system faults. These faults include: GNSS signal failures, sensor failures or communication failures. GNSS signal failures will include satellite and receiver clock failures, ionospheric and tropospheric failures, multipath, noise, and satellite outages. Sensor failures will include inertial sensor drifts, noise, and wheel slippage among others. Communication failures refer to failures in the communication between the prototype and other systems, such as the EVC. The validation environment will be the tool used to carry out all tests in order to validate the developed prototype
- perform integration, test, and validation of the TRL 4-5 HSL/Main Line prototype in the field, augmented by simulation models as needed. Defined test cases and perturbation scenarios will be evaluated in order to address the most critical issues of the Generic Safety Case which will be verified according to the achieved field test results.
- develop a prototype that will be installed in a test vehicle and integrated with ETCS/OB part; the prototype will be operated in a real railway environment and then this operation will be evaluated, validated and documented; the operation of the prototype will be performed and validated in the Czech Republic on a regional line and a selected main line; cooperation with an independent safety assessor (ISA) is envisaged (either on an open call basis or via subcontracting).
- carry out field test activities to verify & validate the developed proposed solutions and to contribute to the assessment of the behaviour of the demonstrator. The validation will be integrated with the micro satellites contribution.
- Provide a further modification of comprehensive Performance Analysis Tool for more formal validation purposes. The Performance Analysis Tool developed in T2.4.3 will be enhanced to take

into account the evolving requirements for on-train position in ETCS especially MOPS or equivalent. The intention is to contribute to the formal validation process through the provision of a rigorous tool.

- Provide RAMS method, certification inputs. Traditional RAMS analyses are not adequate for wireless systems. GNSS performances and RAMS requirements differ. New RAMS methodologies will be developed within this activity in order to qualify the safety levels of GNSS-based solutions.

#### 2.5.4.6. Planning and budget

IP	TECHNOLOGY DEMONSTRATOR	TASK	TRL	2016	2017	2018	2019	2020	2021	2022	2023	2024
IP2	TD2.4 Fail-Safe Train Positioning (including satellite technology)	task 2.4.1	NA									
		task 2.4.2	NA									
		task 2.4.3	NA									
		task 2.4.4	NA									
		task 2.4.5	NA									
		task 2.4.6	6									
		task 2.4.7	NA									
		task 2.4.8	NA									
		task 2.4.9	NA									
		task 2.4.10	NA									

Estimated budget of the TD (including EU funding and Open Calls): 24.29 M€.

### 2.5.5. TD2.5: On-board Train Integrity

#### 2.5.5.1. Concept and Objectives of the On-board Train Integrity

The Train Integrity is an on-board function responsible for verifying the completeness of the train, while the train is in operation. This TD consists concretely in monitoring the status of the train's tail: if the last wagon is regularly advancing in a coherent way in relation to the movement of the remaining train, then Train Integrity system can easily deduce that everything is working properly. In cases where this does not happen, the on-board system should detect the anomaly, indicating the possibility that the train is no longer intact, namely that one or more carriages have been separated from the remaining convoy. Obviously the latter case would constitute a serious danger for the next train, being a possible unexpected obstacle on the line, and therefore should be promptly reported to the signalling system.

The key issue of Train Integrity is that this function becomes a need for the implementation of more efficient signalling systems based on concepts like Moving Block or Train Position delivered by on-board equipment. Systems based on these concepts will deliver very significant advantages in terms of capacity, shorter headways; capital and maintenance cost, removal of track infrastructure for block detection; resiliency, and others such as compatibility among lines, etc.

In particular, the adoption of the moving block concept, as prescribed by ERTMS L3 and CBTC systems, implies that the train integrity monitoring and detection could not be carried out by fixed wayside infrastructures. Conventional train detection systems such as track circuits, axle counters and others, could be used just as a fall back system or to confirm the train position in degraded situations.



In addition to the new functional and performance requirements, the On-board Train Integrity (OTI) could be the enabler in getting the economic sustainability of new railway lines, especially for freight and low density mixed-traffic lines. In these cases, the OTI allows the elimination of fixed infrastructures along the line, relying on the autonomous position and integrity information with consequent important economic advantages.

To achieve all the above results independently from the trackside infrastructure, the train Integrity must be guaranteed by the train fulfilling a SIL 4 Safety Integrity requirement obtaining it as overall result at system level.

The solutions depend strongly on the installed electrical and communications infrastructure on-board the train, and the composition criteria for the train itself. The main and hardest scenario for the (OTI) function is found in traditional freight trains made up from individual cars which are not equipped with any electrical nor communications infrastructure. In order to provide suitable also in the latter case, energy harvesting solutions will be included in the technology research.

For this challenge it is expected that the tasks associated with Train Integrity demonstrators will strongly interact with IP1 (via TIU) and other forecasted IP2 topics.

Moreover, as secondary objective, this TD will analyze if it is possible to fulfill also the requirements that come out from IP5, especially from TD5.1, in order to provide also useful information during the phase of composition of the trains, reducing time and costs and facilitating intermodal services.

In practice, this additional investigation could help to find dual use technologies that can be applied also to every coupling and decoupling operation, then not only when the train interruption is accidental. In order to obtain this secondary goal, it will be important to jointly define a functional interface, necessary to extract all the additional required information.

The primary objectives of this TD are anyway aimed to define and prototype an innovative on-board Train Integrity solution, based on suitable architectures and components, to fulfil several SPDs requirements and to guarantee safety and assessing mechanisms for easier authorisation/standardisation.

The main goal of the solution must be:

1. Autonomous localisation of the train tail without interaction with trackside equipment;
2. Capability to establish a wireless communication between the tail and the front cabin, in order to transfer the confirmation of integrity, without any trackside network support, in the case of absence of a hardwired train communication line;
3. Safe detection (SIL-4) of train interruption, filtering false alarms conditions;
4. Innovative solution to supply the required power for OTI equipment in freight convoy, where the solution will involve both the generation of energy and its possible storage.

The following table summarizes the **objectives** and related deliverables of this TD:

**Table 15: Objectives and Deliverables**

Objectives	Result	Practical (concrete) Deliverable
Solutions for on-board train tail detection.	Autonomous on board localisation of the train tail, without interaction with trackside equipment's, maximising the possible interactions with IP2 TD4	Specification, development and demonstration of on-board train tail detection, based on autonomous localisation (interactions with IP2 TD4 expected)
Solutions for direct transfer of the train's tail position information to the train front cabin, without any trackside support	Two different solutions for freight and passenger convoys, respectively: 1) wireless communication between the tail and the front cabin, without any trackside network support, in the case of absence of a hardwired train communication line. 2) Interface with TCMS network, maximizing the possible interactions with IP1 TD1.2	Specification, development and demonstration of two different solutions for freight and passenger's convoy: 1) wireless communication between the tail and the front cabin 2) Interface with TCMS network.
Solutions for safe detection (SIL-4) of train interruption.	Solutions for train interruption detection, filtering false alarms conditions, etc. suitable to fulfil SIL-4 requirements	Specification, development and demonstration of safe detection (SIL-4) of train interruption
Solutions for autonomous power supply of OTI equipment.	Solutions for the autonomous power supply of OTI equipment for freight lines, including generation of energy and its possible storage	Specification, development and demonstration of autonomous power supply of OTI equipment

### **2.5.5.2. Technical ambition of the On-board Train Integrity**

Train Integrity Monitoring System Working Group (TIMS WG) of the former EEIG ERTMS Users Group finalized its work on the TIMS Functional Requirement Specification (FRS). The foreseeable requirements of ETCS L3 have been considered within the UIC ERTMS Regional project and a pilot application on a Swedish regional line.

Nevertheless the lack of suitable solutions on trains, that don't have electrical network, limits the introduction of ETCS L3 to passenger lines or corridors operated with state of the art trains equipped with a train bus system.

Analyzing the patent applications in this field, they were more numerous in the early 2000s but were not followed by as many applications in recent years. The field in which most of the patent applications have been focused is related to the freight lines due to the lack of electrical infrastructure along the trains and the need for tracking goods. This is most challenging but will offer the most promising market and is the aspect on which more efforts are being focused.



Analyzing the overall picture, it seems quite obvious that a reliable solution could be constituted by integrating more technologies and making sure that the functions that constitute the OTI cooperate among them.

The following table summarizes how this TD will progress the state-of-the-art and overcome today's limitations and difficulties:

**Table 16: Comparison between state-of-the-art and future of On-board Train Integrity**

State-of-the-art	Future On-board Train Integrity
Today the Train integrity function is mainly operated at the trackside, using very expensive infrastructure along the lines.	The Onboard Train Integrity system will be operated exclusively onboard, without any involvement of the trackside part.
Train integrity mainly depends on the presence of an overall electrical network along the train. When this network is missing, there is only the air brake pipe as a possible exploitable link between the wagons, besides the mechanical coupling	The On-board Train Integrity system will be able to adapt to the various typology of on-board physical infrastructures and to operate even in the absence of these, such as in the case of freight lines
Most of the present solutions on the market are mainly based on the detection of brake air pipe pressure reduction on the tail. This phenomenon is more evident in the tail, while it is not obvious in the front cabin, due to delays. At present the performances are not satisfactory and are not suitable to guarantee safety	Solutions adopted for train interruption detection and train completeness monitoring will be able to filter false alarm conditions, and will be suitable to fulfil SIL-4 requirements.
Higher cost of maintenance is especially unaffordable in freight and regional lines, due to the presence of equipment along the lines	Removal of trackside costs and minimisation of costs on the onboard side

This state of the art constitutes the baseline against which the project will compare its progresses.

### **2.5.5.3. Specific Demonstration activities and contribution to ITDs/SPDs**

#### **Demonstrators to be developed within TD 2.5**

The demonstration of the achievement of the TD2.5 results will be obtained in two stages.

The first one will consist of laboratory tests performed on prototypes and mock-ups, aiming to verify and demonstrate their right technical choices and to allow the performance analysis.

All the candidate technical solutions that should cover the most critical requirements will be considered. It is expected in particular that the technologies focused on train interruption detection and on wireless communication from the train tail-to-front side communication will be analysed with the highest priority. Particular care will be paid to the feasibility studies that should verify the capability in filtering false alarm conditions, and the suitability to fulfil SIL-4 requirement even if this will be obtained at system level.

All the technologies under tests will be also demonstrate their energy efficiency and the suitability to operate in harsh environment, and therefore it is important to remark that they all will be mainly destined to fulfil first of all the freight & low traffic lines requirements.

As secondary objective the laboratory tests will evaluate the possibility to adapt the candidate solutions or to find dual use technologies for train completeness monitoring, covering in this way also some additional requirements that could come out from IP5, especially from TD5.1. In this case the solution should be able to provide useful information during the phase of composition of the trains, to every coupling and decoupling operation, and not only when the train interruption is accidental.

As relevant part of the laboratory tests, it is important to underline the relevance, in a first phase, of the simulation aid. Specific models and simulation tools will be adopted with the aim to verify in advance the performances and the suitability of some specific solutions as well as predicting and analysing specific their behaviours that could be observed in a more complex way at system level.

One of this complex behaviour could be the case of the interactions foreseen with TD2.3, with the need of simulating some specific Moving Block scenarios, and more in general the integration with the ETCS/ERTMS system.

The TRL for all prototypes to be reached is 5 to 7.

Current technical gaps will be covered by Open Calls, as described below.

In a second stage, the TD2.5 results will be demonstrated in a real environment, in order to validate what will be already demonstrated in laboratory and in particular the suitability to operate in harsh environment, and in with high energy efficiency. The real environment will be selected to demonstrate in particular the suitability of the candidate solution for freight & low traffic lines applications.

#### **Interactions with other TDs/ IPs.**

Concerning the tests in a real environment, the following TDs will be considered, in order to verify if it will be possible to perform the TD2.5 tests in synergy with them:

- IP 2, TD 2.1 – Adaptable communication;
- IP 2, TD 2.3 – Moving Block;
- IP 2, TD 2.4 – Fail Safe Train Positioning.

#### ***2.5.5.4. Impact of the On-board Train Integrity***

The main innovation is to identify a rigorous but efficient and practical approach based on the following principles:

- To follow an approach based on the existing solutions –adequately improved if needed- and some new technologies to be developed or integrated with others within the Project.



- To define a number of different system architectures (system scenarios) relevant to this function to be able to identify a number of “Train Integrity Product Classes”, according to the system scenarios they can be applied to.
- To define specific requirements for each OTI Product Class providing a path to facilitate the design and deployment of the systems.
- To provide the information requirements to the current OTI solution vendors and offer them ways to improve their solutions in collaboration with the JU.
- To identify some new technology approaches and perform feasibility studies and research aiming for its application.
- To assess the products adapted by the collaborating vendors and facilitate its integration into the demonstrators.
- To demonstrate both by means of simulation and in real systems the expected outcomes of the technology.
- To take a significant step to the standardisation of Train Integrity function and certification of products.

In order to support the competitiveness of the EU, this TD will:

- Achieve a technological leadership and high safety targets;
- Start and consolidate a standardisation process of the final solutions, taking into account broader system requirements;
- Contrast the competition of non-European suppliers, more focused on providing vertical solutions which are targeted at subsystem level, opposing a strong orientation towards the setting of an overall system view;
- The implementation of the TD results will enable the competition of European industries also in markets increasingly dominated by PTC based solutions offered by the American industry. This is the case of the freight lines, as well as regional, in low traffic scenarios, such as the case of mineral trains;
- To offer tangible benefits to the end user:
  - Increase capacity of lines, allowing the implementation of moving block, according to ERTMS level 3 specifications;
  - Improving the reliability and safety levels;
  - Decreasing in dramatic way the wayside infrastructure costs.

In order to guarantee the compliance with the EU objectives, this TD will deliver a solution which will allow a line capacity increase. Furthermore it will raise the levels of safety of signalling systems, while reducing investment costs.



### **2.5.5.5. Implementation of the work programme**

#### **T2.5.1 – Train Integrity Concept**

This task will study, through market investigation, the existing Train Integrity technologies & related products, analysing their technical suitability for the detection of the train interruption and the train completeness monitoring.

The S2R members will:

- define the scenarios and product classes (with particular focus on freight & low traffic lines);
- Perform the market investigation, and the analysis of the existing TI technologies & products;
- define the target scenarios and the associated product classes (with particular focus on freight & low traffic lines);
- investigate and analyse the possible use of wireless sensors and/or transponders technologies, including their networking issues and safety aspects, incl. the applicability of radio technologies to determine the distance between the tail and the front cabin of the train;
- analyse the possible installation options, related to the devices that could be required at the end of the train, considering the operational rules, the required components for power supply generation & harvesting and the asset management. Perform the feasibility study concerning the use of GNSS-based solution for train tail localisation.

#### **T2.5.2 – Definition of Requirements**

In this task the definition of the requirements and functional specifications of the On-Board Train Integrity will be managed. Furthermore, the architectures and related test scenarios, the test cases and the procedures will be identified (with particular focus on freight & low traffic lines and regional lines).

The S2R members will:

- develop the Requirements and Architecture specification for a Train Integrity Management System;
- consider the relevant markets according to T2.5.1 results and contribute in particular to the definition of requirements for test scenarios, the test cases and the related procedures;
- analyse the additional requirements coming from IP5, with the aim to investigate a possible extension of the On-board Train Integrity solution, and the related additional functional interfaces;
- review the requirements related to radio communication aspects, on the basis of the habits and operational rules typical for Central and Eastern Europe railway networks;

- contribute on radio communication requirements, in particular on their availability, environmental and low power consumption characteristics, Interference with other radio systems, and safety related aspects, finding the suitable solution;
- define suitable system requirements to guarantee the a SIL4 architecture and low power consumption;
- Specify functional and interface requirements for: 1)a GNSS-based train tail locator, analysing possible synergies with TD2.4, and 2)the communication topics of the train integrity system and possible synergies with TD2.1;
- deal with the modelling and test scenario generation to validate the requirement specifications.

### **T2.5.3 – Technology Research and Development**

The goal of this task is to research and develop the candidate new technologies, to be adopted for On-Board Train Integrity. In particular these technologies will provide solutions for train interruption detection and train completeness monitoring, filtering false alarm conditions, and suitable to fulfil SIL-4 requirement at system level. In this task several feasibility studies will be carried out. Mock-ups and performance tests in laboratory are foreseen, aiming to the technical choice that will consider also the energy efficiency and the suitability to operate in harsh environment.

The S2R members will:

- perform the Research & Feasibility studies of candidate new technologies for freight & low traffic lines, developing the related Mock-up and performance tests in laboratory for the validation of the technical choice;
- design a solution integrating status data of the braking system and smart algorithms based on GNSS parameters or on inertial sensors;
- Perform a feasibility study of candidate new technologies for Regional Line solutions;
- Perform a feasibility study of candidate new technologies, for the specific relevant market segments that will be indicated by requirement definition task;
- analyse either GNSS based positioning or inertial sensor technology or both, based on the requirements and on the results of technology feasibility studies;
- contribute to the application of wireless backbone, by creating dynamic wireless nodes infrastructures across train compositions, for implementing train integrity and completeness control;
- identify the suitable technology for the rail segments, in particular for freight lines, contributing to the feasibility study of the candidate solutions;
- Define the system architecture focusing on train tail localisation and on-board wireless communication, including wireless reliable IP sensor based resilient communication architecture able to monitor train integrity;



- develop the required validation tools, namely, the on-board train integrity determination simulation platform and the formal modelling to validate functional requirements of new train integrity solution;
- Provide the RAMS analysis by means of conducting reliability, availability, maintainability, and safety (RAMS) studies in conformity with RAC (Risk Acceptance Criteria) guideline by ERA and CENELEC 50126 standard.

#### **T2.5.4 – Adaptation of existing solutions**

The objective of this task is to adapt the existing solutions, in order to fulfil the OTI requirements. These activities will include the required in-laboratory tests and the preliminary safety assessments.

The Open Calls will enable performing Research activities and Development on radio communications and energy harvesting technologies.

In particular the need to develop antennas and radio communication equipment suitable for installation in the queue of a very long train, optimizing its characteristics even in situations of NLOS has been identified.

In parallel it is considered appropriate to explore the theme of energy generation, considering both the issues of the most appropriate source (compressed air in the brake circuit, vibrations, etc.), and the best way to store it.

#### **T2.5.5 – Demonstration and Assessment**

The goal of this task is to integrate and demonstrate the On-board Train Integrity prototype performances, in two steps, starting from laboratory tests, simulating the selected scenarios, and finally testing in a real environment. The completion of the first safety assessment is foreseen.

The S2R members will:

- contribute to the integration and demonstration activities of the OTI prototype for freight & low traffic lines scenarios, starting from the laboratory simulations and tests, to the final test trial in a real environment;
- contribute to the development of a demonstration unit suitable for both mainlines and regional lines;
- Carry out laboratory tests and pilot line tests on a regional line, using the defined test scenarios and test cases;
- Perform the preliminary safety assessments of candidate new solution and define the complete test scenarios, test cases and procedures;
- Define and implement laboratory validation environment for TI solutions. In particular, focus on the integration with the ETCS/ERTMS railway laboratories RailSiTe® and RailDrive® by defining generic validation and verification processes and proposing standardisation rules for the assessment of the train integrity simulation prototype (an on-train GNSS-based locator, wireless communications);

- Perform dependability study for the candidate solution, developing the safety integrity level (SIL) allocation methodology to the new train integrity solution on different rail segments, assessing (performance and security evaluation included) innovative wireless communication technologies for train integrity, integrating dependability and safety requirements (e.g. SIL 4 requirements) and contributing to the safety case for certification and authorisation.

### **T2.5.6 – Standardisation proposal**

The goal of this task is to provide an analysis of the impacts on the whole signalling system, in terms of prospective standardisation, defining a preliminary proposal. Since nowadays the train integrity functionality is performed by track side equipment influencing the interlocking, the new architecture, interfaces and processes have to be rearranged by considering the paradigm shift determined by the autonomous on board detection.

#### **2.5.5.6. Planning and budget:**

IP	TECHNOLOGY DEMONSTRATOR	TASK	TRL	2016	2017	2018	2019	2020	2021	2022	2023	2024
IP2	TD2.5 On Board Train Integrity	task 2.5.1 Train Integrity Concept	TRL2									
		task 2.5.2 Definition of Requirements	TRL2									
		task 2.5.3 Technology Research and Development	TRL3/4									
		task 2.5.4 Adaptation of existing solutions	TRL2/4									
		task 2.5.5 Demonstr. and Assessment	TRL4/6									
		task 2.5.6 Standardis. Proposal	TRL6/7									

Estimated budget of the TD (including EU funding and Open Calls): 9.95 M€.

### **2.5.6. TD2.6: Zero on-site testing (control command in lab demonstrators)**

#### **2.5.6.1. Concept and objectives of the Zero on-site testing Demonstrator**

System- and Integration Test (SIT) is a fundamental method of system verification across many different industrial sectors. Various experiences show that the effort and time consumption for the SIT is about 30 percent up to 50% of the project time. Due to the complexity of signalling systems and the differences between sites, a large amount of tests must be carried out on-site. On-site tests take about 5 to 10 times the effort compared to similar tests done in the lab. Reduction of on-site tests for signalling systems is hence a reasonable approach to reducing testing costs.

However, technical means for testing in the lab need to model the reality sufficiently and the assessment and authorisation process needs an essential minimum of on-site tests serving as evidence for valid system behavior and also to confirm lab test results.

This implies to improve the lab testing capabilities by broadening the test scope as well as to decrease the number of onsite test cases until the normative and legislative borders are reached.

To reach such an ideal state the following strategy will be applied to make lab tests strictly focused on real needs and make it easier to control the costs:

- Definition of a dedicated system test architecture for the lab tests;
- Specification of a standardized method to derive and describe test cases;



- Fixing a common test process framework.

The planned system test architecture should allow for a flexible creation of signalling environments and should serve for stepwise integration approaches as well as for different ranges of complexity. Application of real system components and simulated environment elements in various mixes should be supported. These configurations should be easily created and controlled. The architecture should provide a unified interface concept and standardized interface specifications to allow several suppliers and also third parties to contribute to the same testing project. A unified test derivation method, being essential to make test case portfolios optimised and comparable, should be based on existing model-based approaches and should provide a unified description method including standard notation.

A common test process framework is needed to achieve a unique understanding of test scopes. It should define elementary terms needed for a common understanding as well as define a process flow showing inputs, required steps and interaction with other processes for assessment and authorisation.

Signalling system projects are expected to grow in complexity in the future resulting in a growing number of suppliers being involved in the system testing. This will require a clear process definition as mentioned above but also rules about responsibilities and obligations of the different parties.

The topics explained above focus on the first constraint, the improvement of the technical means for system testing. The strategy to handle this constraint is focused on the following topics:

- Definition of common criteria for test case selection which need to be executed onsite as a minimum to provide sufficient evidence for validation;
- Definition of conditions under which a minimum of onsite tests can serve as a confirmation for the lab tests to be meaningful.

The treatment of these two topics requires close cooperation with European organisations dealing with the harmonisation of assessment and authorisation. Other industrial sectors like automotive and aerospace integrate and test as well complex, vital systems. Experiences and best practices developed in these sectors should be used to optimize the SIT approach. An in depth analysis of best practices and their applicability in the railway domain is therefore an essential part of this TD.

The key objective of **Zero on-site testing** is to perform System-and Integration Tests in laboratory instead of testing on-site in order to:

- Save time (95%);
- Save effort (95%);
- Reduce necessary resources (99%).



The following table summarizes the **objectives** and related deliverables of this TD:

Objectives	Result	Practical (concrete) Deliverable
Assessment of today's practice of field testing	Assessment report with identification of improvement areas, where field testing can be avoided by better lab test coverage	Assessment report with clear proposals for shifting tests from the field to the lab
Benchmarking with automotive/ avionics industry	Best practices from other industries working in safety critical environments to minimize Field Testing	Benchmarking report with best practices and concrete improvement ideas to implemented in lab testing of rail signalling
Definition/implementation of a dedicated system test architecture for lab testing supporting Zero On-site Testing	System test architecture that is close to the field and open to equipment of various suppliers	Validated test environment according to system test architecture including adaptors for standard simulation environment.
Definition of a common test process framework	Unique understanding of test scopes, test aims	Clear common understanding of the different test phases with clear in-and outputs allowing the optimisation for certain Field/system test efforts
Specification of a standardized method to derive and describe test cases	Optimised test coverage and a model based derivation of test cases in order to benefit from growing tools support. Easy exchange of tests/information about tests by a unique description method	Improved test case derivation/test coverage by model based approach. Easy Exchange of test information between different participants of integration projects.

### **2.5.6.2. Technical ambition of the Zero on-site testing Demonstrator**

Today, the situation can be characterized as follows:

- In most cases the suppliers do product testing in the lab.
- System testing is done in the lab but still with large amount on-site.
- On-site testing is often used as fallback, if lab testing was not finished in time.
- Lab testing is done mainly by supplier-specific process and testing environment.
- Collaboration of with different suppliers is always causing the need of sophisticated adaptors with less.
- chance to reuse in subsequent projects but increasing costs.
- The test case derivation is not comparable since different approaches have been applied, which are proprietary.



Reference to previous research:

A first attempt to unification of testing of ETCS systems has been realized by the ETCS Interoperability (IOP) working group of UNISIG developing standards for testing IOP in lab by means of

- Definition of the scope of IOP testing, the overall process and embedding into other processes of assessment,
- Specification of a generic test architecture, a unified interface concept and dedicated interface specifications for ETCS constituents, and
- Specification of a test case description format, a semantic description for track data and a related track data notation.

Subset ID	Title	Content
SS-110	UNISIG Interoperability Test – Guidelines	Introduces basic principles, process, environment and management of IOP testing
SS-111-1	Interoperability Test Environment Definition (General)	Defines the generalized IOP Test environment architecture in terms of its structure, components and their function and finally the essential interfaces
SS-111-2	Interoperability Test Environment Definition (FFFIS for TCL-OBU Adaptor)	Detailed specification of the functional interface specification between the OBU and the IOP test system in terms of scenarios and messages
SS-111-3	Interoperability Test Environment Definition (FFFIS for TCL-RBC Adaptor)	Detailed specification of the functional interface specification between the RBC and the IOP test system in terms of scenarios and messages
SS-111-4	Interoperability Test Environment Definition (FFFIS for TCL-RBS Adaptor)	Detailed specification of the functional interface specification between the RBS and the IOP test system in terms of scenarios and messages
SS-111-5	Interoperability Test Environment Definition (FFFIS for TCL-RIU Adaptor)	Detailed specification of the functional interface specification between the RIU and the IOP test system in terms of scenarios and messages
SS-112	UNISIG Basics for Interoperability Test Scenario Specifications	Definition of a guideline for test scenario specification and management and a common track description notation

The CCS TSI will also be taken into account and analysed for interaction.

The test architecture defined in these subsets is focused on IOP testing. The basic concepts are:

- A centralized flow control for test execution
- An generic adaptor concept to map proprietary interfaces to standard test interfaces

Figure 53: General Architecture

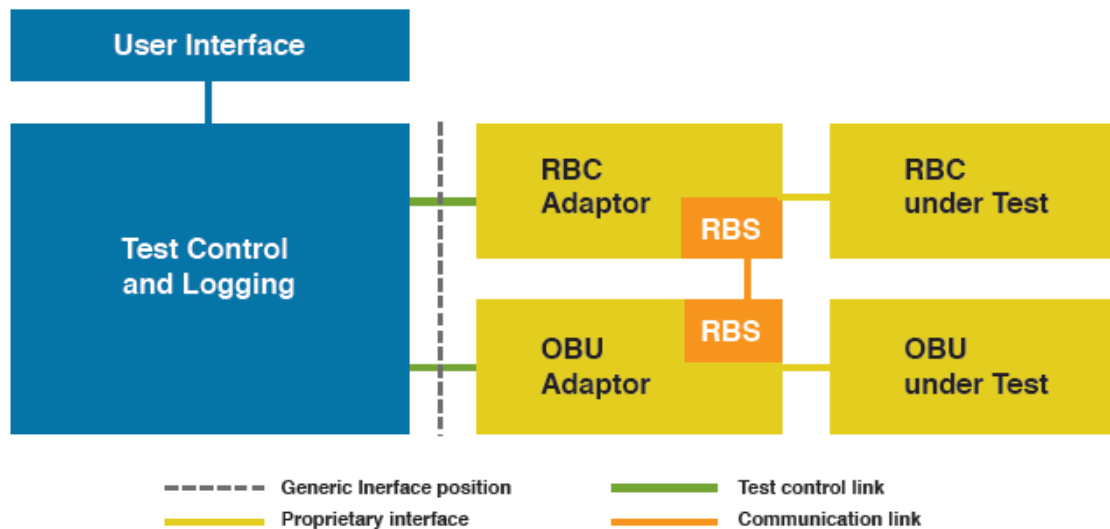

The centralized flow control (Test Control and Logging – TCL) is crucial to enable test automation and a common meta-language for test case specification and engineering data is necessary.

Special focus has to be put on accurate site data to bring ‘lab testing’ as close as possible to the field reality.

More practical experiences are needed for this topic to continue with the development of a common meta-language, which needs to reflect a well-defined level of abstraction and must have a standardized structure and notation. This will enable more easy understanding of test case specifications coming from different sources and helps to apply tool chains for effective test case implementation also in proprietary environments.

This modular approach of this architectural concept was already applied successfully in several ERTMS/ETCS projects and supports the collaboration between different suppliers in a single lab as well as in remote labs as well as remote testing in distributed labs. While in the past the remote connection was restricted to the attachment of ETCS constituents by their specific adaptors via area-wide networks, in the future it need to be extended to the direct interaction between separate test environments and different TCL components.

This architectural concept was already applied in several ERTMS/ETCS projects with positive feedback from customers. In addition to regular suppliers, independent labs have shown interest in this and have applied this concept for their test floors. Finally, more and more suppliers have applied this architecture also for their in-house product testing, which also provides positive synergy effects.

This baseline will be extended with more practical experiences, further development of a common meta-language with standardized structure and notation, by extending the adaptor concept and by adding more standard interfaces dedicated to further signalling system components.

The definition of a common test process on the European level was started years ago but did not achieve a common result. Contributions have been provided so far from a supplier and user perspective.



A set of rules for the collaboration of different suppliers has been drafted recently by the European Lab Strategy Group and is under review by all involved stakeholders.

Developing a laboratory test environment and an optimised test process for railway signalling systems under consideration of best practices from other industrial sectors will significantly improve the efficiency of projects and will provide easier control of costs.

### **2.5.6.3. Specific Demonstration activities and contribution to ITDs/SPDs**

The main goal of the specific demonstration of this TD is to demonstrate the reduction of the amount of field testing as mentioned in the chapters above.

Therefore the following main results will be provided:

- Definition of a dedicated system test architecture for the lab tests;
- Specification of a standardized method to derive and describe test cases;
- Fixing a common test process framework;
- Definition of common criteria for test case selection which need to be executed onsite as a minimum to provide sufficient evidence for validation;
- Definition of conditions under which a minimum of onsite tests can serve as a confirmation for the lab tests to be meaningful.

Taking the current ETCS IOP experiences into account the demonstrator will provide a test architecture based on the IOP framework. A major improvement will be in the possibility of distributed test- and simulation environments as well as virtualized test labs.

- The distributed test environment will give the possibility to integrate multiple test candidates based on standardized interfaces.
- Based on this distributed environment the within the TD defined test process will be verified and validated.
- In addition a clear distinction will be given between generic application and specific application. It will be shown that the effort for the specific application test and validation on site can be reduced.
- Based on the results of TD 2.7 (formal methods) a formalized approach for data engineering as well as the derivation of test cases will be shown.

The different participants will prove the approach using their products integrated into the distributed test bench.

The major challenges of this demonstration will be in the harmonisation of test strategies, test automation and harmonizing generic applications.



#### 2.5.6.4. Impact of the Zero on-site testing Demonstrator

The main outcomes of **Zero on-site testing** are:

- Identification and analysis of best practices of automobile and aeronautics industry;
- Definition of a dedicated system test architecture and standardized interfaces for lab tests, including remote tests;
- Practical validation of test environments in all relevant configurations with product demonstrators;
- Specification of a standardized method to derive and describe test cases;
- Definition of common test process framework including real time distributed testing connecting existing test labs and e.g. on site tests (hybrid testing).

This effects following strategic impact:

Strategic Aspect	Key Contribution of the Technical Demonstrator
Support the competitiveness of the EU industry	<ul style="list-style-type: none"> <li>- Overall cost reduction in projects due to more and better lab testing instead of field testing</li> <li>- Overall quality improvement due to improved test coverage by doing more simulated test (fault insertion, load)</li> <li>- Introduction of 'state of the art' technology in testing and benefitting from growing number of supporting tools.</li> <li>- Reduce the number of test resources needed to be built in different places.</li> </ul>
Compliance with EU objectives	<ul style="list-style-type: none"> <li>- Interoperability tests can be done more easily in the lab (adaptors/ simulators, etc.)</li> <li>- Standardisation will be supported</li> <li>- Competition will be increased</li> </ul>
Degree of maturity of the envisaged solutions	<ul style="list-style-type: none"> <li>- The methods/ improvements will be proven in real pilot projects focusing on the new developments of other TD's.</li> </ul>

By the end of the proposed work the market will benefit from a unification of testing. Integration of complex rail signalling solutions will be significantly easier and the test coverage will be increased before solutions enter the field, because all suppliers can use the architecture, the test process framework, etc. to perform/improve their in-house testing.

The evolution of rail signalling solutions clearly shows a trend to standardise the communication interfaces, starting with the physical transport medium to protocols and eventually defining standards for interfaces between different components of a solution such as interlocking-interlocking, interlocking-RBC, interlocking to field elements, etc. This will be supported by the envisioned test environment.



Finally, increased in-lab-testing with support of simulators allows for much more faults in the system being detected as ever could be tested in the field. By this the probability of outages in the field due to errors will be reduced, leading to significantly increased availability of infrastructure.

### **Impact on Shift2Rail targets**

Capacity:

- Minor impact on this target. Only indirect, since it could help to bring new technologies, which have a direct positive effect on capacity, earlier into service;
- Less outage times in the field since time for field testing will be reduced to the absolute necessary minimum.

Competitiveness:

- Major impact on this target. Less impact on traffic due to faults in signalling systems and field testing, since more will be tested in the lab and test coverage, esp. fault insertion will increase with lab testing/ simulation;
- In addition it helps the European industry to deliver complex solutions with low LCC and low impact on operational traffic. New and more advanced technologies/ methodologies (like Model based test design) will help the industry to work 'state of the art' and benefit from the growing number of tools.

Operational reliability:

- Major impact since outage time of lines which are in operation will be reduced: tests in field are significantly limited;
- Testing more in lab with support of simulators allows to stimulated much more faults in the system than ever can be tested in the field. By this the probability of outages in the field due to errors can be reduced.

### **Expectation for exploitation and possible market uptake**

By the end of the proposed work the market will benefit from a unification of the testing as it was demonstrated successfully in the EMTS/ ETCS interoperability test context some years ago.

It will make integration of complex rail signalling solutions easier, even between different suppliers for different components, it will increase the test coverage before the solution enters the field and by this will dramatically reduce the cost for field testing, which today is a remarkable cost factor in the delivery of solutions.

The plan for the use of the results:

- all suppliers (established and new upcoming ones) can use the architecture, the test process framework, etc. to perform/ improve their in-house testing. It will reduce the field testing and by this the cost on one side, on the other side it will reduce the impact on traffic when introducing bug fixes or feature upgrades;

- whether or not we even could think of a kind of ‘certification authority’ for rail signalling systems is too early to decide on or even to propose. This could have a commercial aspect for sure.

Further research could concentrate on the assessment and authorisation process which is not part of TD2.6.

### **Contribution to TSIs and standards**

The evolution of Rail signalling solutions clearly shows a trend to standardize the Communication interfaces, starting with the physical transport medium to protocols. This will have a huge impact on testing as well. Therefore we must have a close view on these trends which define Standards for the different interfaces between the different components of a solution (interlocking-interlocking, interlocking RBC, interlocking to field elements, etc.). Various operators are here active and we have to take this into account for the test environment which will be designed and constructed.

### ***2.5.6.5. Implementation of the work programme***

#### **Description of Tasks:**

#### **TD2.6.1 – Assessment of status quo in field test and benchmarking**

The objective of this task will be to assess the current field test activities and to identify work packages which can be shifted to lab testing. The expectation on one side is to identify areas where lead time and cost of field testing can be reduced and on the other hand to improve further on the quality of delivered solutions. A benchmarking of Rail Signalling activities with other safety critical industries like avionics, medical, automotive will be a strong element of this task.

The S2R members will collaborate in this task by defining the work description, selection of a subcontractor (consulting company or university) and will regularly supervise/ review the progress of this assessment/ benchmarking.

The S2R members will contribute with:

- knowledge of specifications in the Southern, Central and Eastern Europe railway networks,
- telecomm assessment based on previous experiences,
- benchmarking with automotive, aviation and other sectors.

Open calls should provide other safety critical industries state of the art: medical, automotive, etc.

#### **TD2.6.2 – Definition of test process**

The objective of this task is to define and agree on a common test process framework and to identify a standard method to derive and describe test specifications by taking into account the results and recommendations of Task TD2.6.1. Main justification is to easily exchange test specs between the different parties involved in field testing.



The S2R members will:

- collaborate by presenting and comparing their test processes, the way the test specifications are derived and designed and compare it with best practices from other industries;
- develop methodology and tools on how to derive the needed test specifications. Preferred is a model based approach;
- present and compare the test processes used on Central and East European railway networks and contribute to the test process definition and model development and test specification development;
- Perform safety case analysis, deliver formalized operational rules, formalized test cases within the scope of e.g. corridor 1 for ETCS System;
- provide test case generator for creation of test cases and test scenarios based on statistical/empirical information;
- focus on the telecoms domain and the RAM (without safety, but with security) procedures and contribute in the definition and implementation of methods to create, enhance and align test specifications and test results, based on the gained in multi-vendor test campaigns (NVIOT, TEN-T, etc.);
- Define a common test framework and intends to operate in order to set up a common database, they plan to focus to define a standardized engineering and operational rules;
- develop specification and definition of tests, covering functionality and operational fitness (on board and track) and safety, the derivation of tests not only in traditional way but also model based (maybe both) and with saboteurs, interferers and noise in testing.

Open calls should provide safety critical (RAMS) experts collaboration to the definition of the test process.

### **TD2.6.3 – Define general architecture for test environment**

The task targets the creation of a new architecture of a test environment where many activities which are currently done during field testing can be executed. It needs to support different technologies but also products of different suppliers. Beside the architecture of this future test environment there should be a clear definition of which elements need to be real (HW and SW), where is real SW sufficient (HW virtualized) or where simulators are needed. There should also be a consensus reached where the test environment(s) should be built up.

The S2R members will:

- contribute specifically with the knowledge of simulator development (RBC, OBU, IXL) and verification and interfacing it to the tested subsystem;
- deliver feedback from field tests and contribute to ETCS System requirements of test architecture;





- contribute for embedded verification and validation modules for test analysis and reporting and for automated data integration and mapping capabilities for supporting interoperability testing;
- Define high-level architecture for common test framework, with special focus on the specification of integration and middleware layer for the simulation environment, coming from RSB technology in TD2.9, for encouraging interoperable interfaces between real and simulated components from different suppliers;
- Define a full end-to-end network to increase the test coverage and maximize off site testing, incl. network function virtualisation and use of simulators within the telecoms domain;
- define the architecture of test environment that allows On Site Test execution in the laboratory, allowing: exchanging of information between different modules involved in the simulation, common time/space synchronisation between modules, remote connection with third part equipment, automatic test execution, automatic logs and juridical files downloading and storing;
- Define the requirements on the test architecture to integrate the contributed components and perform the envisioned tests.

Open calls will provide IT expertise in virtualisation, test houses and railway R&T centers.

#### **TD2.6.4 Define generic communication model**

The goal of this task is to develop a communication model between the different components of the test environment as defined in TD2.6.3, based on a strong and close cooperation with other standardisation bodies and teams. Standard Interfaces between the products of different suppliers will be one of the key activities to ensure effort and lead time reductions. Specification for simulators should be developed defining which interfaces should be implemented in simulators.

The S2R members will:

- Develop specification of higher layers of communication protocols, specification of test scenarios and test cases keeping a relation to the results of TD2.7 Formal methods and following the achievements of the IOP group of UNISIG, esp. SS-111;
- deliver a standardized Application Programmemeing Interface (API) to ensure ETCS reference OBU within test environment and supplier;
- define the acceptance criteria and requirements for IOP tests within the scope of e.g. corridor 1 of ETCS System;
- contribute in the area of internet based runtime environment for distributed testing with web clients for control, reporting and result analysis, auto-email notifications;
- Collaborate in definition and specification of interoperability interfaces in common test framework, for both real and simulated components, in order to encourage interoperability between technologies from different suppliers;
- Collaborate in definition and specification of inter-application layer for allowing end-to-end data-exchange for systems (real or simulated) connected to the simulation environment. Application



of TD2.7 technologies of Universal Data Model for specific ERTMS applications data will need to be adapted to the needs of test framework for creating of standardized data model for describing, defining and modelling railways infrastructures for testing scenarios;

- define which interfaces or protocols in the communication layer are required, which require implementation, which can be simulated and which will be triggered by traffic generation;
- investigate, model and develop functional partitions or subsystems within the test environment, which allow independent test campaigns focusing on a subset of functions and features, while avoiding disturbances on other subsystems;
- contribute with the experience regarding the identification of interfaces that have to be standardized in order to allow communication between equipment suppliers, and contribute to their standardisation;
- define the common model to be used;
- contribute to defining interfacing and communication of contributed components to the test environment.

Open calls will provide Interoperability and standardisation stakeholders.

#### **TD2.6.5 Develop/ validate test environment**

The objective of this task is to develop the test environment according to the outcome of Tasks TD2.6.3 and TD2.6.4 and to build it up. Especially the development of simulators if needed is content of this task and might be done by subcontractor. In a second step it has to be validated that the environment is according to the requirements. At this stage of the project it is not yet defined where to build up the environment physically.

The S2R members will:

- contribute in the development of the simulator and its verification and validation;
- contribute with an integrated simulation capabilities for addressing user interaction; considering modules required for tests but currently not connected to the test environment; simulating operational scenarios based on available production plans and infrastructure data up to national level;
- analyze and develop new simulation environments within the telecommunication domain, while leveraging the existing test systems and enriching the toolset with new functions, especially for the next gen network as defined by TD2.1;
- setup the test environment on a distributed basis with key test functions or subsystems virtualized or deployed in different locations to maintain the proximity of subject matter experts to the respective network system;
- contribute in the development of two simulators: Subset 094 compliant test bench and RBC test bench;

- contribute with the conformity and Interoperability test environment for on board and track, the integration of model based emulation of communication via air gap and GSM-R (including degradations) and the validation of the lab environment for tasks related to the contributed components and methods.

Open calls will provide the contribution of Infrastructure & Operation Validation, railway R&T centres, test houses and notified bodies.

#### **2.5.6.6. Planning and budget:**

IP	TECHNOLOGY DEMONSTRATOR	TASK	TRL	2016	2017	2018	2019	2020	2021	2022	2023	2024
IP2	TD2.6	task 2.6.0	N/A									
		task 2.6.1	2/3									
		task 2.6.2	2/3									
		task 2.6.3	3/4									
		task 2.6.4	4/5									
		task 2.6.5	4/5									

Estimated budget of the TD (including EU funding and Open Calls): 20.9 M€.

### **2.5.7. TD2.7: Formal methods and standardisation for smart signalling systems**

#### **2.5.7.1. Concept and objectives of Formal Methods and standardisation for smart signalling systems**

##### **OBJECTIVES**

- To develop formal methods for requirement capture, design, verification and validation.
- To standardise crucial interfaces between parts of selected System Platform Demonstration scenarios using formal methods.

##### **OUTPUTS**

- Formal methods for requirement capture, design, verification and validation.
- Standardised interface between selected subsystems of System Platform Demonstration scenarios.

##### **IMPACT**

- Increased market competition
- Improved interoperability
- Improved reliability
- Increased standardisation
- Cost savings in:
  - design



- implementation
- tests and commissioning
- operation and maintenance
- training
- upgrading
- Shortening Time-to-market of new Products.

Objectives	Result	Practical (concrete) Deliverable
Develop formal methods for requirement capture, design, verification and validation	Efficient requirement capture, design, verification and validation. Cost savings Time-to-market savings	Formal methods suitable for and applied to standardisation of interfaces and operational scenarios
Standardise crucial interfaces between parts of selected System Platform Demonstration scenarios using formal methods.	Increased market competition Cost savings Time-to-market savings	Standardised interface between selected subsystems (FIS, FFFIS) of System Platform Demonstration scenarios

Standardisation is one of the key drivers to decrease LCC of signalling systems. Common interfaces will open the market for increased competition and reduce the time needed for adaptation, testing and commissioning. Formal methods and tools will play an important role in achieving these goals.

The main idea of the work is to make use of the advances in formal methods in general – languages and tools for specification, analyses like different variants of model checking, automations of development activities – and in particular in other domains of embedded systems (e.g. aerospace) for the rail sector, with an emphasis on information processing equipment in signalling and control. This means that approaches and results will be taken up and adapted or extended appropriately. Semi-formal languages with a less rigid semantics will be integrated to cover areas difficult to formalize and to involve people with a less formal background.

General principles to be observed are

- Accessibility of proposed solutions to all stakeholders
- Use of existing approaches where available
- Compatibility with existing practice
- Observing the existing framework of development in the rail domain
- Applicability in other lines of activities within Shift2Rail

Applications which should be addressed by the work will include:

- Interface definitions of signalling components



- ETCS/ERTMS components
- Testing as addressed in TD6 (“Zero on-Site Testing”)

Each subtask will include the following general steps:

- Collecting information on useful existing approaches. This may be realised through the integration of partners via open calls.
- Selecting what is suitable, identifying needs for adaptations and additions and performing the activities necessary for completion in dedicated projects.
- Verification of the results on System Platform Demonstration scenarios and case studies.

**Interaction with other TDs (of the same IP and/or of the other IPs):**

IP2: In particular TD2.3, TD2.5, TD2.6 but also other TDs will benefit from the findings in this TD regarding specification and validation.

**2.5.7.2. Technical Ambition of the Demonstrator**

Standardisation of signalling systems, rules and procedures has historically proven to be difficult due to the very different rules and traditions among railways. The standardisation of ERTMS has however proved it possible to achieve standardisation of functions and interfaces.

The ERTMS specifications do not however cover all interfaces and also not engineering and operational rules to the extent needed. This means that different railways and suppliers design their own solutions, which hampers interoperability and increases cost.

Several recent or ongoing projects are addressing these issues from different perspectives. Even though some of the projects like Cesar have been very successful their results are only partly relevant for the signalling systems of the railway. In the case of Cesar the project deals with embedded systems which have different conditions than signalling systems

The project Open ETCS objectives are the creation of a formal specification of the ETCS OBU functionality according to UNISIG Subset 026 and a formal interfaces description with respect to the state of the art TSI subset FFFIS for ETCS OBU. It includes an executable software package generated from the formal specification and a non-vital implementation of that software for laboratory test, simulation and reference purposes.

The objective of NeGST was to optimize and standardize the *approval procedure* and re-design the operating system for control and safety technology. The project addressed testing concepts in the context of approval.

Eurointerlocking dealt with the standardisation of signalling interlocking. In this respect the project failed but knowledge on the topic was achieved.

INESS had a similar purpose but a wider scope (including definition of a common core of functionality and some standardized interfaces for interlockings). It got further than Eurointerlocking but still did not reach the goal. The main barriers identified were the lack of a clear business case for the

standard interfaces, at the side of the industry, and the difficulty to agree on common standard interfaces, at the side of the Infrastructure Managers.

The project euLynX was started recently. It is a project involving a number of European railway undertakings and railway infrastructure managers. The project will run for 3 years and includes the development of standardized interfaces between subsystems at the standardized interlocking layer of the control command system of railway process control. That is on existing systems.

The last few years a number of techniques and tools have emerged as viable solutions for the formal specification and verification of critical systems. In particular, the field of *model checking* techniques has witnessed in the last couple of decades a growing interest in both the academic and the industrial fields, with an increasing number of tools crossing over from the academic domain to real-life industrial applications. Available tools address a wide range of verification issues, with tools often specializing in specific kinds of systems and properties to be analyzed (e.g., hard real-time vs. probabilistic ones). A non-exhaustive list of some of the best known tools includes classic model checkers such as NuSMV ([nusmv.fbk.eu](http://nusmv.fbk.eu)) and SPIN ([spinroot.com](http://spinroot.com)), the Uppaal ([www.uppaal.org](http://www.uppaal.org)) model checker for continuous-time, real-time systems, PHAVer ([www-verimag.imag.fr/~frehse/phaver\\_web/](http://www-verimag.imag.fr/~frehse/phaver_web/)), which targets hybrid systems, and PRISM ([www.prismmodelchecker.org](http://www.prismmodelchecker.org)), which handles probabilistic models. In recent years, Satisfiability Modulo Theories (SMT) solvers such as Z3 ([z3.codeplex.com](http://z3.codeplex.com)) or MathSAT ([mathsat.fbk.eu](http://mathsat.fbk.eu)) have been used as underlying engines to formal verification tools, such as ones that are targeted to verification of safety properties of source code such as CBMC (<http://www.cprover.org/cbmc>) and Kratos ([es.fbk.eu/tools/kratos](http://es.fbk.eu/tools/kratos)).

In the railway domain, formal methods have been applied for some time, in particular to signalling systems. For example, in the EuRailCheck project they have been successfully used to validate parts of the ETCS specification, using strict formal languages as the modelling front-end for formal methods. It is interesting to notice that, when confronted with the issue of choosing a notation to use to describe systems, practitioners in the railway domain typically select UML and scade-based (UML- or Scade like, at least) notations.

As we can see all these projects give valuable input to TD7 but they do not cover or reach what is proposed to be done in Shift2Rail or more specifically TD7. Their results should be consolidated and integrated into a methodology that can be used for further standardisation of railway signalling systems including ERTMS.

State-of-the-art	Formal methods and standardisation for smart signalling systems
Formal methods have advanced much in other domains outside the railway signalling area.	Modern methods for requirement capture, design, verification and validation adapted and applied to railway signalling.
Standardisation of interfaces very difficult to achieve.	Methodology developed based on formal methods and applied to crucial interfaces.



### **Vision and Objectives:**

Enable improvements of the development and implementation process of rail systems by making use of state of the art formal methods.

Provide standardized means (languages, methods, tools) for

- Requirement capture and formulation
- Specification of interfaces
- Design activities
- Verification and validation

The work can also help coordination of activities between the TDs that need to define their Engineering and Operational Rules.

### ***2.5.7.3. Expected impacts***

#### **Strategic impact**

In the following section, a summary of the strategic impacts produced by the implementation of the TD results and discoveries is given. This is organized along three main aspects: the support to the competitiveness of the EU industry, the compliance with the EU strategic objectives, and the degree of maturity of the solutions envisaged to be realized and put into practice in the railway sector. This is expected to provide an overview of the effects generated at larger scale by the application of the TD results.

Strategic Aspect	Key Contribution from the TD
<p><b>Support the competitiveness of the EU industry</b></p>	<p>In railway business, work is done along sequential phases of the lifecycle. Main phases are focused on Requirements Definition, System Design, Component Design, Component Implementation, System Integration, System Validation, Acceptance, Maintenance. A key issue for competitiveness is to guarantee the correctness and completeness of the output of every phase, otherwise defects will propagate along further phases appearing at the System Validation or Acceptance phase. For instance, removal of defects evidenced in the Acceptance phase due to incomplete requirements will require costly rework along several previous lifecycle phases. Use of Formal Methods in the Requirements Phase, including among the Requirements the Engineering and Operational Rules will allow for better requirement verification with less effort, but the main advantage is to provide better quality requirements for the following phases and substantially decrease the need for rework, improving both the cost and the time-to-market of the solutions in all lifecycle phases. As a consequence, cost reduction is achieved in design, implementation, tests and commissioning, operation and maintenance, training, and upgrading of the system.</p> <p>Railway Signalling Systems are complex systems subjected to strict safety requirements. Huge efforts must be devoted to their integration and proof of safety compliance. The standardisation of Interfaces facilitates the building of complex systems starting from existing standardized components, saving both costs and time. Applying formal methods for both the Definition and Validation of the Interfaces will provide better evidence to compliance and will decrease the effort devoted to such tasks.</p> <p>Shorter time-to-market and time-to-operation of the systems will be achieved, not only because of the decrease of efforts, but also from the setup of more rigorous and reliable process based on the application of Formal Methods.</p>
<p><b>Compliance with EU objectives</b></p>	<p>Formal methods and standardisation of interfaces facilitates the setup of complex systems needed to put into practice the innovative ideas proposed by Shift2Rail for railway Command, Control and Signalling needed to increase the capacity and reliability of railway transport across Europe, decrease costs and make the railway even more energy-efficient.</p> <p>The progress expected in formalising the Operational and Engineering Rules on this TD will be a facilitator for the difficult process of harmonising these rules as needed to increase the interoperability of the European Railway System.</p>
<p><b>Degree of maturity of the envisaged solutions</b></p>	<p>Although the basis for formal methods is well established, the difficulty is to adapt it to each specific problem and its adequacy and usability for the relevant stakeholders. In terms of Technology Readiness Level (TRL), the work to be done into the TD is to be done in the range from TRL-4 (Technology Validation in Lab) up to TRL-6 (Demonstration in relevant environment). The “relevant environment” will be the System Platform Demonstration scenarios, and a key issue is to guarantee the adequate level of participation of the different stakeholders involved, with specific attention on the several addressed fields: System Requirements, Design, Validation, Interface Definition and Operational Rules.</p> <p>The same range of TRL apply for the Task 2 regarding Interfaces and Task 3 regarding Operational Rules.</p>



#### 2.5.7.4. Implementation

The R&D activities should cover at least:

- (TRL 4 to 6) The development of a semi-formal language for requirement capture, design, verification and validation. Model based design and test generation will be performed. Open standards will be proposed.
- (TRL 4 to 6) The standardisation of crucial interfaces between parts of selected state of the art interfaces FIS and FFFIS spec and test spec validation.

#### T2.7.1 Formal methods

The S2R members will perform a state of the art search and the taking up of results from previous projects. Then the development of methodical approaches for specification, design, verification and validation will begin. Then the work on methods, languages and tools will begin. Then this will be applied to selected System platform demonstration scenarios. Finally the work will be validated and reviewed.

#### T2.7.2 Standardized interfaces

The S2R members will perform a state of the art search and the taking up of results from previous projects including EuLynx. Then the development of specifications on FIS and FFFIS level will begin on selected interfaces. Then test specifications will be produced and the interfaces tested. Finally the work will be validated and reviewed.

#### 2.5.7.5. Planning and budget:

IP	TECHNOLOGY DEMONSTRATOR	TASK	TRL	2016	2017	2018	2019	2020	2021	2022	2023	2024
IP2	TD2.7	task 2.7.1 Formal Methods	4-6									
	Formal Methods	task 2.7.2 Standardized Interfaces	4-6									

Estimated budget of the TD (including EU funding and Open Calls): 8.03 M€.

### 2.5.8. TD2.8: Virtually – Coupled Train Sets (VCTS)

#### 2.5.8.1. Concept and objectives of the Virtually – Coupled Train Sets Demonstrator

Many European railway lines are very busy today and have a problem to handle the requested capacity. New lines are built and tracks added to existing lines, but this is slow, expensive and will not create the needed capacity in the near future. The objective of VCTS is to increase line capacity by at least 100% (depends on existing infrastructure, traffic patterns and train characteristics) without building new tracks, and do this faster and with less investment and lower maintenance and operational cost, by improving the technical systems (mainly signalling).

The current lines must be better exploited by increasing the performance and functionality of current systems in order to improve headway, optimise the use of station platforms, optimise timetables and solve traffic conflicting situations through smarter and more flexible functionality and behaviour.



The proposed TD will explore the innovative concept of 'virtual trains' capable of operating physical trains much closer to one another (inside their absolute braking distance) and dynamically modifying their own composition on the move. This is a total deviation from the traditional railway operational concept, used since the days of our grandfathers.

The proposal of the study is to start from the current interoperable signalling system that is UNISIG BL3 ETCS/ERTMS. It is deemed essential because:

- ERTMS is the common signalling system already applied and in service for many years.
- The common knowledge of ERTMS facilitates the understanding of what is necessary to upgrade in order to get the required behaviour.
- Simplify the interface with the signalling system avoiding to study the impact of TD8 on the legacy applications so making work more effective and really feasible.

VCTS, whose complete title is *Virtually-Coupled Train Sets and smart switching and crossing* has several sub-functions; each of them needs specific investigation. They are:

- Increase the length of a (virtual) train to allow more passengers and/or freight wagons to pass in a given time (reduce headway between physical trains in virtual train).
- For passenger traffic, overcome platform length limitation (1st part of train going to platform x; 2nd part to platform y).
- For freight traffic, allow longer and heavier virtual trains designing lines with shorter passing sidings than would otherwise be required.
- Reduce the headway, the distance between two trains, when the 2nd (i.e. the following) train has to change direction / route.
- The impact of VCTS on operational rules – i.e. what combinations of trains are allowed / forbidden (e.g. dangerous goods and passenger trains)
- Suitable train-control support tools for efficient operations of VCTS – e.g. what combinations of trains and services to avoid (e.g. commuter train ahead of long-distance high-speed train)

All VCTS subjects have basically the same objective which is to reduce the headway and increase the line capacity. The new required functionality could be seen as the extreme limit of the moving block on relative braking in order to compact several trains dynamically on the fly, up to have logical coupling, “virtual coupling”, of trains while they are moving, removing the current “one block, one train” limitation. The function is not limited to the on board environment; in order to work properly, it needs new features and upgraded functionalities in the wayside signalling and supervision systems as well.

This can be summarized in the following table:

Objectives	Result	Practical (concrete) Deliverable
Increase line Capacity by Reduced Headway, reducing maintenance cost in relation with its best use / max capacity.	Find technical solution to overcome the current limits due to signalling and supervision systems, investigating the Virtually-Coupled Train Sets concept.	Complete study identifying the architecture, functions, interfaces and operational procedures that are necessary to achieve the objectives.
Enhanced capacity means increased competitiveness.	Move goods and passengers from road to rail.	Same as above
Reduce Environmental Pollution	Move trains more efficiently and move goods from road to rail	Same as above
More passengers per “train”	More capacity and better use of existing station platforms. One convoy can use several platform tracks.	Same as above
Lower investment costs	Adding signalling/electronics instead of tracks	Same as above

**Interaction with other TDs (of the same IP and/or of the other IPs):**

- IP1 TD1.2 (TCMS) – cooperate to integrate solutions for train-to-train communication
- IP2 TD2.3 (Moving Block) – cooperate to identify similarities and common approach and solutions
- IP2 TD2.5 (On Board Train Integrity) – cooperate to understand how Train Integrity information can be used inside a train consist virtually coupled (convoy of trains).
- IP2 TD2.2 (Railway network capacity increase – ATO up to GoA4) – cooperate to understand how the train regulation and automatic driving can be performed dynamically inside a convoy of train.
- IP 2 TD2.4 (Satellite-based Positioning) – cooperate to use possible improvements to odometry data for train location establishment / distance between trains in Convoy.
- IP2 T2.6 (Zero – on site – testing) – cooperate to achieve the best testing capability reducing the need to carry out test activities on site. Improve simulation technology.
- IP2 TD2.10 (Formal methods for smart signalling system specs) – cooperate to follow common methodology in writing documents (FRS, SRS).
- IP2 TD2.11 (Cybersecurity) – cooperate to verify the need to encrypt data for train to train coms.

***2.5.8.2. Technical ambition of the Virtually – Coupled Train Sets Demonstrator***

The current railway operations are based on very old basic principles:

- track is divided into blocks/sections;
- maximum one train is allowed in a block in normal operations;

- before allowing a train to enter a block, technical systems are used to ensure the block is free of railway vehicles.

In addition, a modern safety system ensures trains do not violate the trackside permissions:

- supervised / ensured by a safety system consisting of interlocking and trackside + on-board ETCS/ERTMS

This typically limits the capacity of a railway line to one train per two blocks, absolutely less than one train per block.

The ambition of the VCTS system is to allow more than one train into each block (of sufficient length) by allowing the following train(s) to run as close to the preceding train as to just be able to stop in time to not run into the other train if it stops. This can increase line capacity with more than 100%, possibly 300%. The solution is to link the preceding train with the following train by data radio to create a virtual coupling, running the trains together.

Function	Today	With Virtual Coupling
Train separation	Separate blocks	Much less than a block
Train separation	Defined by block sizes	As close as coms and controls delays and braking distance variations /uncertainties permits
Following train driven by	Driver	Virtual Coupling OB Computer(s)
Track occupation detection	Track Circuit (axle counter)	VCTS system
Scheduling of trains – high level	Planning system, Train Control	Planning system, Train Control
Locating train	Track Circuit (by block) (axle counter)	VCTS by measuring distance from balises passed and train length
Scheduling/running trains – low-level/real-time	Train Control / Driver	VCTS
Route setting requests	Train Control / Interlocking operator	VCTS

The approach of Virtually-Coupled Train Sets (VCTS) is a new paradigm of the train control as it will overcome the current limitations of the signalling and apparently it is in contrast with the basic train separation principles. In fact theoretically the new system should be able to:

- Manage dynamic train convoy joining/splitting also during normal traffic and running time
- Manage new train separation systems overcoming the limitation of the brick wall concept
- Manage train convoys (at first at least with two trains) and dynamic route setting/releasing through updated interlocking systems
- Accomplish traffic regulation through updated supervision system in order to manage dynamic train consists and timetables for multiple trains joined in a single convoy.



- To guarantee, through updated on board ATP/ATO systems, the safety and the automatic driving according to the new physical constraints and scenario. ATPs/ATOs of different trains would cooperate through a common network in order to achieve the full Convoy Control. That is a new concept which enlarges the current Train Control features
- Overcome the limitation of communication dealing with a new frontier of train-to-train data exchange (new standard interface necessary)

It is trivial to say that all the above points must be achieved without reducing, instead improving the current level of safety in all working scenarios. That all clearly shows how deep the impact of the new functions on the existing Train Control system will be as it moves toward a dynamic Convoy Control system.

### **Expected impacts**

The vision is to have a very effective line management through the innovation of signalling and modifying the basic concepts of train separation (Moving Block on relative braking). In the future the so called Flexible Signalling will allow dynamic approach of train control in which train on board systems will become even more “smart”.

That must also be seen in a very wide connection network in which each signalling element will have and will exchange the rights and the information to perform functions with the other signalling elements of the network.

That view opens not only the possibility of trains communicating with each other but also new horizons in which the traditional signalling logic, for instance of the classic interlocking could be shared and activated by on board subsystems when needed in terms of controlled area in time.

Virtually Coupled Train Sets is seen as the first attempt to overcome the limit of train control taking also insights from automotive whereas the idea of automatically driven car inside a full integrated road environment is a subject of studies and research. So this input could be used also for information in the Virtually Coupled Train Sets.

### **Outcome and KPIs:**

- Line capacity increasing without track enhancement
- Improving headway and by that increase passenger & goods transportation capacity
- Better exploitation of station platforms which don't need to be built for the max passenger volume
- New frontiers of signalling because these new concepts open up novel approaches to train controlling
- No need to have long trains, just short and modular vehicle-sets

Very effective for freight and mines Railways in which the need is to use as much as possible the given short time slot for freight trains and to have very low cost railway mine (no need to have heavy and long trains but only modular wags which could start from different parts of the mine and



virtually couple together in a single train convoy during transportation time and finally split again to discharge materials where needed).

### **Expectation for exploitation and possible market uptake**

As said before the function is a big improvement of train management. The challenge of the analysis and the aim of technical proposal is to make a system that is easy to implement with few but scalable features and not need big modifications of the basic supervision/signalling in order to envisage real and immediate advantage in the application of VCTS. That would be the key point for improving market attractiveness.

With that basis, a good exploitation of the function is expected, especially where the cost of the alternative railway lines improvements (station structure, signalling, others) is high compared with VCTS solution cost making the application of the Virtually Coupled Train Sets features suitable.

The goal of the TD is just to find and promote solutions which can be easily deployed with high Benefit/Cost ratio.

#### ***2.5.8.3. Specific Demonstration activities and contribution to ITDs/SPDs***

TD 2.8 VCTS is a purely theoretical / analytical TD. The concept is so far ahead of current operations that the work is limited to a thorough analysis of the concept, its implications, constraints, possible achievements, safety aspects and impact on the existing railways, including the existing safety systems as well as the trains, and the needs for new functionality and communications links.

The TRL is 2-3. Part of the analysis can be complemented by simulations.

#### ***2.5.8.4. Impact of the Virtually – Coupled Train Sets Demonstrator***

VCTS will analyse the impact of a completely new operating context. It will quantify what line capacity increases can be achieved under different circumstances and in different contexts, it will identify the necessary functional modifications and additions that are needed and which railway subsystems need to be modified. VCTS will also analyse any limitations in usefulness depending on operational situations and patterns.

VCTS in itself is a completely new way of operating the railways, and as such is likely to have an impact on most aspects of railways, e.g.:

- Scheduling of trains, time-tables
- Capacity of lines
- All vehicles with a drivers cab that need to operate on VCTS lines in VCTS mode
- ERTMS
- Operational rules
- Drivers, train control operators, maintenance staff
- Control centers



- Interlocking, RBC
- Track Maintenance Procedures

Strategic impact of the TD:

Effects	VCTS advantages
Rail competitiveness improvement	Increased capacity, more frequent services
Less investment cost	No new track to build, signalling is cheaper
Less traffic disruptions	No disruptions caused by building new tracks / lines / longer platforms

#### **2.5.8.5. Implementation of the work programme**

The work will provide a technical analysis of suitable behaviour in different traffic situations (e.g. freight only, various combinations of freight, commuter and high-speed trains, behaviour at junctions, terminals), analysis of safety aspects, analysis of necessary technical functions/subsystems, communications capacity, expected performance in different situations, functional specifications. Draft functional architecture SAS, FRS and FIS specifications will be produced.

The methodology used will be technical analysis of:

- the concept;
- the impact / limitations of railway operating conditions and operational scenarios;
- the availability and safety aspects in the new VCTS context of the different sub-systems involved in the VCTS concept as well as possible new safety issues created by VCTS;
- the system architecture and necessary interfaces;
- estimating the performance;
- impact on the railway system / network – what subsystems and/or functionality need to be modified and how, what needs to be added.

#### **T2.8.1 – Virtual Coupling Concept**

TheS2R members will define the concept, boundaries & behaviour.

The necessary functions, e.g. virtually couple and un-couple trains, control of non-leading trains, have to be defined.

An important aspect to be defined is possible alternative architectures and different operating scenarios (e.g. following train controlled through ETCS supervision of data from RBC or from train in front, or following train driven from train in front with ETCS inactive, the possible radio

communications systems and architectures including communications as a service (bearer-independent communications)).

Open Call are foreseen to provide an analysis of radio aspects, e.g. direct radio communications within the VCTS / through external network / through RBC, what radio systems are available and the related functionality.

### **T2.8.2 – Safety and Performance Analysis**

The risk analysis will look at the impact of traditional, existing risks in the context of VCTS, as well as new risks created by the VCTS concept – e.g. today, when one train has passed on a single track, there will be no train for a while (until the block is free), but in VCTS another train can follow very closely.

New risks will be identified and analysed, e.g. multiple-train accident caused by derailment, cars on level crossings, level crossings not released until the complete virtually coupled train has passed it. Both technical risks and risks related to staff as well as the general public behaviour will be analysed, including identification of potential new risks caused by the new concept.

The impact of new risks, including risks caused by the uncertainty/variations in brake effort, impact of uphill gradients and curves on braking distance of first train, communications capacity / delays /noise etc., will be analysed.

The possible performance / capacity improvement and the risks involved will be analysed for a set of common operational/traffic scenarios, e.g. high-speed line, commuter line, mixed traffic line, to identify operational scenarios where VCTS is effective and the possible capacity improvements VCTS can produce.

The impact on performance and safety of variations in parameters like communications delays, brake performance and differences in brake performance, location accuracy, track data accuracy and weather conditions.

The general impact of aerodynamic interaction between train-sets in different scenarios (e.g. freight/passenger train, different speed ranges, different intra-train distances) will be analysed.

Open Calls will be related to risk identification and analysis and performance variations analysis.

### **T2.8.3 – Feasibility Analysis**

This task will analyse the concept feasibility, given the previous Safety and Performance Analysis.

The work will analyse what radio system / network could be used and whether it would be available, whether frequencies would be available. And what would be the cost of installation and operation.

One issue is if there is a solution or reasonable trade-off between safety and performance that delivers enough improvement in capacity to be useful. It will also be analysed if VCTS will be politically acceptable to member states as well as the public. The way to introduce VCTS will also be analysed – can it be used on a few important lines only? How many trains must be upgraded to VCTS to actually improve the line capacity? What impact will it have on operations and capacity if only a few trains have VCTS / if only a few don't have it?





Estimated budget of the TD (including EU funding and Open Calls): 4.8 M€.

## **2.5.9. TD2.9: Traffic management evolution**

### ***2.5.9.1. Objectives and Concept of a new advanced Traffic Management System***

The Traffic Management System (TMS) needs to provide status and forecast information for internal and external clients in order to support dynamic decision making and alignment of the current travel/transport demand. This also includes dynamically updated travel/transport schedules. Having performed several implementations of train request/offer/order interfaces between IMs and RUs

Automation of processes, a significant higher Integration of status information of the wayside infrastructure, trains, maintenance service and energy resource management as well as advanced communication and security systems are mandatory requirements for future Traffic Management.

Enhanced capacity will result from applying new drive modes such as Moving Block developed under TD2.3 supported from advanced traffic control principles

Advanced automated decision support tools and standardized workflows presented on a standardized operator workstation will optimize the usage of resources.

A base requirement for a future Business Services such as Traffic Management System or other Asset Management Systems is the design and development of an interoperable framework and flexible and bearer independent communication infrastructure to fulfil high performance and high availability requirements. Plug and play of new functional service applications will provide flexibility to implement business applications from various sources to meet future rail traffic demands.

In parallel the integration of existing functionalities via adaptors will enable to integrate legacy service applications to the integrated system.

External clients and services have access to all relevant information available in the system via Web-Services. This will enable the generation and enhanced support of new services and businesses around the Rail Transportation segment.

Standardized system architectures, data structures and interfaces will be designed and developed to simplify the business process enabling rapid and cost-effective engineering and deployment as well as improved interoperability in line with improved upgradeability, scalability and maintenance of the overall Traffic Management System and other rail services.

This project will deliver the tools for Infrastructure Managers to meet the demanding environmental targets in terms of Energy reduction through an efficient Traffic Management supported by mobile dynamic applications such as Driver Assistance System and automatic driving modes. Algorithms to optimize Noise can be included allowing for reduced activities during certain time periods.

TD2.9 aims at a significant higher Integration of status information of the wayside infrastructure, trains, and maintenance services together with management of energy and other resources.

Demands from external clients will be also dynamically incorporated into the process via Web Interfaces. Cross-cutting activities address the design and development of tools and processes to allow the Data exchange with services developed under IP3 TD6, TD9 and IP5TD1, TD2 and TD5.



Traffic status information will be available for web based external services e.g. services developed under IP4 TD2 and TD4.

Dynamic integration of traffic status updates for passenger/freight information is subject of the research and design & development activities in IP4 and IP5. The cross-cutting activities under I2M address the integration between Traffic Management (IP2), Asset status now and forecasting (IP3) and Freight Operations (IP5).

The new Traffic Management System is based on standardized frameworks, data structures, real time data management, messaging, and communication infrastructure including Interfaces for internal and external communication between different subsystems, applications and clients.

Target is to allow Plug-and-Play installation of functional service application modules and automated data exchange between them. In this respect, the format of data and Interfaces used in such systems will be specified as a new standard taking existing standards into account.

A standardized workstation will be specified and developed to address the previously heterogeneous working processes.

New functionalities will incorporate rules and control on the TMS level for all new developed functionalities elsewhere in IP2, e.g. Moving Block (TD3), Security aspects (TD11).

The Lighthouse project Horizon 2020 (IN2RAIL) includes works which are directly linked with the programme of IP2 TD9.

All new functional service applications specified and developed within this initiative will be supported by fully or semi-automated processes. This will also include automated push/pull communication procedures with other internal and external services. However a manual push notification process will be implemented to allow specific operations supervised from operator.

New service application functionalities for Traffic Control will be specified, developed and tested. These functional modules are addressing both improvement of functionalities which exists already such as Conflict Detection and Resolution and new application such as the operation of new drive modes Moving Block, ATO integrated with advanced Driver Assistance Algorithms. New principles of managing dynamic changes in traffic demand and assessing impact on traffic quality will be developed and integrated which is a prerequisite to achieve the targeted improvements.

#### ***2.5.9.2. Ambition of the Advanced Traffic Management System***

Most currently deployed Traffic Management Installations have “functional” sections in the control rooms receive different kind of operational information from different systems, like telecommunication systems, interlocking systems, notification systems and dispatching systems and requiring enormous efforts to achieve sufficient transfer of data between functional areas. In order to make a correct decision, the traffic managers and dispatcher need to access different command and control systems in variant location in the command and control centre. This reduces the efficiency and effectiveness of workflow of the traffic managers and therefore business process of the railway system.



Partial automation is available only on sub-system level. Very often signallers are required to check the status of the infrastructure by observing on-screen symbols on regular intervals. Status of maintenance related services, energy resources and other traffic related assets have to be manually integrated into the TMS process.

The proposed approach towards a future Traffic Management System within IP2 TD9 and the related cross-cutting activities of I2M follow an integrated and coordinated approach to this subject and will use the results from Horizon 2020 IN2RAIL, and previous projects such as FP7 ON-TIME (2011-2014) and FP7 Capacity4Rail (Start in Oct. 2013).

The new TMS will be structured as a flexible overlay which is able to integrate step by step existing and new subsystems and applications providing or enabling automated processes including the communication between services. This will provide the required scalability and flexibility within the choice of functional service module of different suppliers.

New train control and command related developments in Shift2Rail e.g. Moving Block can only deliver the targeted improvement of operation if they are supported by appropriate applications within the Traffic Management process. Traffic Management is the bracket to most of the innovations set to be achieved in IP2.

Status information from assets which will be developed within IP3 TD6 and data exchange with energy managing systems in the first phase is essential for the Traffic Management process to ensure the achievement of the targeted KPIs. Within the crosscutting activities the link between Traffic Management and freight Operations (IP5) will be developed.

The activities in Shift2Rail will enable further services to be integrated into the system according the specifications developed.

The Traffic Management process will be designed to allow for full automation but still support the operators' choices.

A workstation meeting all requirements will be specified and developed. This tool will enable sector control of various subsystems on one display together with integrated Alarm Management. A workload analysis for operators with area responsibility and the suitability for Disabled or staff with special needs will be major criteria for the final layout. This will contribute to a significant improved performance of Traffic operations and in parallel to a reduced risk for collisions caused by "non-automated" manual procedures.

Research will demonstrate the new advanced basic Traffic Management principles including Rule and Conflict Management same as Traffic Optimizer processes.

Status and forecast of asset, energy and human resources, maintenance services, as well as security aspects will be integrated in the new specifications and design.

Push notification management to related subsystems will ensure a dynamic update for optimised rail operation.



These new functionalities will enable the achievement of the targeted improvements for increases in capacity, reliability and customer satisfaction and will lead to a strong reduction in CAPEX, OPEX and LCC for Railway Operations.

This Proposal as it is structured, will lead towards industry-wide technical standards oriented to ensure interoperability of technological solutions of different manufacturers, ease acceptance by customers and in general reduce costs and facilitate market uptake.

### ***2.5.9.3. Impact of the Advanced Traffic Management System***

The new Traffic Management System will improve reliability of Train operations in terms of punctuality and availability of wayside Assets by at least for 10%.

The target to increase capacity and at least 10% is realized with the implementation of new functional service modules on TMS level for advanced traffic management principles.

The new Driver Assistance applications will strongly support the increase of customers benefit with increased punctuality and the availability of real time data for improved passenger information.

Standardisation of the frameworks, data structures and interfaces will deliver a reduction of the investment of at least 10% for new integrated installations linking several functional rail services such as Traffic Management, Maintenance Management and Energy Supply. A Standardised Operators Workstation will further reduce cost for investments into workstations operations, training efforts and HW and SW maintenance cost for workstations.

An additional benefit will arise by deploying the specified structures within this project to other services management facilities e.g. Maintenance Services (IP3), Energy Management (IP3), Passenger Information (IP4) and Freight Management (IP5).

The reduction of the operational cost of specific lines or networks can be targeted to be more than 10% compared to a network operated differently than specified under this project. These reductions will mainly arise from increased preventive Maintenance possibilities of the infrastructure resulting in an increased availability of the infrastructure and the reduction of energy consumption of up to 10% compared with the reduction of wear of vehicle subsystems provided through an intelligent Driver Assistance application.

The usage of an intelligent Driver Assistance System will further allow to reduce Carbon emissions and air pollution for specific traffic e.g. Diesel Engines and will contribute to a reduction of noise caused by braking manoeuvres of trains.

This project will provide new international standards for data structure, frameworks and Interfaces of rail services as Interoperability of service application SW modules of different suppliers. Finally, this will lead to much more standardized layouts of future control centres and a high degree of HW independence.

The automation and standardisation of key processes will allow easy cross border operations both passenger and for freight, including management of vehicle resources (locomotives) or train drivers to be able to be controlled from one central control centre or by a series of linked but decentralized sub infrastructures which is key for the further roll out of ERTMS in Europe.

Some of the targets envisaged within this activity depend on inputs provided by other projects within IP2 and IP3. These are mainly the activities addressing new drive modes such as ATO or Moving Block.

A strong dependency of IP2 TD9 is the successful delivery of the lighthouse Horizon 2020 (IN2RAIL) project results as they have been taken out from the initial work programme.

#### **2.5.9.4. Implementation of the work programme**

In May 2015 the Horizon2020 IN2RAIL Project, covering several topics of the initial TD2.9 work proposal has been started. This lighthouse to Shift2Rail addresses the specification of the basic functionalities and architecture for the Integration layer, the application frame work, interfaces to external clients and the standardized operator’s workstation. The availability of IN2RAIL results is mandatory for a successful execution of the TD2.9.

Works carried out under Shift2Rail TD2.9 are targeting enhancements of the generic specifications and architectures developed under IN2RAIL and to complete the overall system structure complemented with specification and development of business service applications and a system demonstrator. These activities address functional specifications, system architectures, processes, data structures, communication processes and interface for the Traffic Management System of the future, considering technologies to be developed and the required requirements and targets to be met. This is based on the need of the Operations and Maintenance of the Infrastructure Managers and Operators and is grouped into functions that deliver it.

In a second phase technologies will be developed, covering the whole development process for the prototype modules needed from basic research, lower level specifications, technology development, prototypes and lab test, leading to results showing their performance and to a full knowledge of these technologies.

In the final phase, the Demonstrator will be commissioned by integrating the prototypes. A full Demonstrator System Test will be followed by the presentation to proof that the Objectives have been met.

#### **Work Breakdown Structure**

Task	Description
0	Technical Coordination
1	Integration Layer
2	Shell for Applications in the TMS (Application Layer)
3	Framework for Traffic Management Business Service
4	Applications
5	Standardized Operators Workstation
6	Functionalities and Interfaces for Dynamic Demand and Information Management
7	Demonstrator



### **Task 2.9.0 Technical Coordination**

Within this task all technical coordination and system engineering activities addressing system or subsystems standardisation and/or technical alignment between for the work programme specified under TD2.9 will be done.

This activity will be carried collaboratively amongst the participating partners

Additionally all topics which need to be aligned with IP3, IP4 and IP5 to ensure compatibility of architectures and data structures, interoperability of the different service applications and the integration of subsystems into the joint framework for Traffic Management and the functionalities and applications developed under this technical demonstrator will be performed.

Within this Task the Technical Management Team for TD2.9 will be allocated.

### **Task 2.9.1 Integration Layer**

The objective of this task is the Development of functional requirements and architecture for the integration layer of the future traffic management system, interfaces able to integrate real-time status and performance data from the network and from the train (e.g. signalling, passenger information, fleet management and staff management systems) based on the specifications developed under IN2RAIL and to develop prototypes up to TRL3/4.

All Partners participating in this task will collaborate to specify the functional requirements and the architecture of the Integration Layer. This activity has started in H2020 IN2RAIL project and will be completed and enhanced within this Task.

Complementing System/sub-system prototypes TRL3/4 including Interfaces and Data Structures demonstrating a successful communication process will be developed and tested. Focus is on:

- Data exchange between Traffic Management System and Asset Management Centre
- Proof of Concept for Functional Interface between Traffic Management System and Signalling Wayside Infrastructure e.g. Interlocking, RBC,
- Interfaces to link Traffic Management System with Passenger Information Systems, Time Table and Fleet & Crew Management,
- Data exchange/communication between Traffic Management System and Operators Staff-Fostering Services,
- Continuation of Analysis, Evaluation and Proof of Concept of Candidate Technologies for the Integration Layer based on the outcome of IN2RAIL.

### **Task 2.9.2 Shell for Applications in the TMS (Application Layer)**

The objective of this task is to finalize the development of functional requirements and architecture for the inter-application layer (internal architecture and communication structure of the business server) of the future traffic management system based on the generic specifications developed under IN2RAIL.



In second step prototypes up to TRL 3/4 including interfaces able to manage real-time status and performance data from the network and from the train will be developed and tested.

All Partners participating in this task will collaborate to specify the functional requirements and the architecture of the Application Layer. These activities have started in H2020 IN2RAIL project and will be completed within this Task.

Part the proposed activities is the development of specifications for RAMS and IT-Security plans to define the organisation and measurements to handle the corresponding issues

The analysis of open-source tools and the evaluation of candidate technologies for integration environments and middleware solutions will be done. This work will start on the basis of IN2RAIL results.

Complementing System/sub-system prototypes TRL3/4 will be developed and tested focusing on

- Interfaces between TMS Framework and wayside Control and Command System (CCS),
- Interfaces demonstrating the ability of the framework to manage Information from Passenger Information Systems, Time Table and Fleet & Crew Management systems,
- Interfaces enabling the demonstration of cloud-based hosting capabilities of the solution/framework,
- Continuation of Analysis, Evaluation and Proof of Concept of Candidate Technologies for the Application Layer based on the outcome of IN2RAIL,
- IN2RAIL Lighthouse Project will specify the basic functionalities and architecture and a proof of concept will be done. Based on these results the prototype developments for subsystems needed to complete the framework demonstrator will be made available for the Partners.

### **Task 2.9.3 Framework for Traffic Management Business Service**

The objective of this task is to develop the frame business service functional application for future traffic management system, with highly automated processes and data exchange integrating information from railway infrastructure, energy, maintenance, train position and other services.

In a second step prototypes up to TRL 3/4 will be developed and tested.

All the Partners participating in this task will collaborate to an integrated Process Image integrating information from Rail Infrastructure, Energy, Maintenance, Train Position and other services and will participate in the research for new Train/Traffic Control Management Algorithms integrating existing applications, new Drive Modes (e.g. Moving Block), Energy and Asset status information in the Traffic Management process.

Complementing System/sub-system prototypes TRL3/4 will be developed and tested focusing on:

- Integration of Energy Saving concepts on Sector or Corridor Level into the Traffic Management process with a further optimisation of integrating of Asset and Energy Management Status information into the process,





- Advanced Conflict Detection and Resolution functionality including validation process for the new Conflict Detection and Resolution sub-module,
- Integration of risk-based information from the Maintenance Service Operations about the condition of infrastructure assets in TMS decisions,
- Part of the work is to develop a risk and IT-security analysis based on the specified system architecture, functionalities and interfaces defined, to deduce safety and IT-Security requirements.

The specification and development of USE Cases for the new developed Train/Traffic Management Principles is foreseen as an Open Call activity under the supervision of the involved Partners of this Task.

#### **Task 2.9.4 Applications**

The objective of this task is the specification and development of business service applications (SW) for the Traffic Management System.

All Partners participating in this task will collaborate to:

- Specify principles, interfaces, functional requirements and process description for an advanced Driver Assistance System on Sector or Corridor Level and will include also those elements/functionalities needed to enable the integration of “Trip” based Driver Assistance on-board based systems. Target is to include algorithms which in the first place secure punctuality but also allow “Energy-Optimised”-Operation both on smart Routing or Trip Optimisation,
- Functional requirements for Moving Block and switching overlay from Fix Block to Moving Block. This works have to be strongly aligned to secure homogeneous operation, engineering and design processes,
- Functional requirements for possession release request management and possession opportunity slot management. This works have to be strongly aligned to secure homogeneous operation, engineering and design processes,
- Supervise the development of Use-Cases for possession release request management and possession opportunity slot management within an Open Call.

In a second step prototypes will be developed and tested such as:

- Prototype demonstrating the Management of an Vehicle based Driver Advisory Systems for Trip optimisation including Energy Efficiency improvement from TMS Level,
- Prototype demonstrating the business service application needed on TMS Level to operate either in Moving Block – or Fix block Mode including all Elements needed for the switching Process including integrated in the TMS process,
- Integrated Traffic Management System with embedded Traffic Forecasting, Driver Advisory and Conflict Detection and Resolution functionality,



- Application(s) for measuring and maximizing capacity at critical terminal stations, optimizing the impact from maintenance work,
- Data-Management, including Sand-Box technology, Disposition and Operation Planning, Possession (Release) Request Management and Possession Opportunity Slot Management,
- Data collection, analysis and reporting services for Business Intelligence;
- Part of this work will be to specify requirements for a Traffic Management process from a customer oriented view, included requirements for the system and for timetable planning, operations scenarios, best practice and benefit of implementation for selected innovations;
- Business applications related to freight such as improved ETA calculation, freight slot planning and management (cross-border, cross-network) and freight related business rules/logic for both.

#### **Task 2.9.5 Standardized Operator Workstation**

The objective of this task is to finalize the specification and development of a standardized operator workstation based on the generic specifications developed under IN2RAIL.

All Partners participating in this task will collaborate to specify the requirements for a standardized operator workstation incl. general display rules, alarm management for new functionalities and suitable for Disabled or staff with special needs. This activity has started in H2020 IN2RAIL project and will be completed within Shift2Rail.

Complementing System/sub-system prototypes TRL6/7 will be developed and tested demonstrating:

- interoperability of different technologies used for a new operator workstation prototype with special focus on aligning the requirements coming from H2020 IN2RAIL project with new information visualisation techniques that can suit the use cases and HMI principles,
- Alarm Management functions,
- Operation control of wayside Control & Command Systems,
- Ability to cooperate with different signalling rules,
- Suitability for Disabled or staff with special needs,
- Demonstrating optimised ergonomics.

The final selection of the structure of the development of the prototype will be made on basis of the available budget for this task and the outcome of IN2RAIL WP7.2 and will be updated before the start of TD2.9.



### **Task 2.9.6 Functionalities and Interfaces for Dynamic Demand and Information Management**

The objective of this task is the specification and development of necessary functionalities and interfaces to enable Information exchange with external clients. The works can be generally divided into 2 Subtasks.

1. Information Management with external clients via Web-IF
2. Information Management with Data Warehouse

#### **Subtask 2.9.6.1 Information Management with external clients via Web-IF**

All Partners participating in this task will collaborate to specify the requirements for a Web interface for external clients to manage provision of updated traffic status information and receive changes in transportation demand. This activity has started in H2020 IN2RAIL project and will be completed within Shift2Rail.

The proposed work will include

- activities to standardize functional modules to enable the usage of tools to improve regulation, time table optimisation, analysis of down time and perturbation management, evaluation of performance, improved analysis of current and future time tables,
- activities to integrate cloud-based asset status information, and matching dynamic real-time demand from IP4,
- development and test of prototypes for external business services for passengers and freight operations including functionalities and interfaces for dynamic demand,
- Detailed design of V-Negotiator plugins including freight related business rules/logic Implementation and test of SW-Prototype.

#### **Subtask 2.9.6.2 Data Ware House (Data Silo) Management**

All Partners participating in this task will collaborate to specify the requirements for a “Standardized” Data Warehouse including standardized Architecture, Data-Structures and Processes needed to manage and access the Data. This Ware House is considered to be subject-oriented, integrated, time-variant, non-volatile collection of data to support the decision-making processes derived from business service applications.

The development of such a standardized Data Warehouse Prototype will then be subject of an Open Call. The resulting development will form the basis for many of the TMS applications which will depend on in-time and “form-fit” delivery of this data source. Therefore, this IT-activity will have to be accompanied and controlled.

### **Task 2.9.7 Integrated Demonstrator**

To proof and validate the targeted achievements of the new Traffic Management System with integration of status information from different services a platform will be established.

All Partners participating in this task will collaborate in providing their services and modules developed under TD2.9 for a demonstrator platform.

Part of this work is the demonstration of new functionalities by running of operational scenarios on partner demonstrators to validate functional specification/ requirement.

#### **2.5.9.5. Planning and budget:**

IP	TECHNOLOGY DEMONSTRATOR	TASK	TRL	2016	2017	2018	2019	2020	2021	2022	2023	2024
IP2	TD2.9 Traffic Management System	task 2.9.1 Integration layer	3-4									
		task 2.9.2 Shell of the Traffic Management System	3-4									
		task 2.9.3 Framework for TMS applications	3-4									
		task 2.9.4 Application	6-7									
		task 2.9.5 Standardized Operator Workstation	6-7									
		task 2.9.6 Dynamic Demand and Information Management	3-4									
		task 2.9.7 Integrated Demonstrator	6-7									

Estimated budget of the TD (including EU funding and Open Calls): 24.4 M€.

#### **2.5.10.TD2.10: Smart radio-connected all-in-all wayside objects**

##### **2.5.10.1. Concept and objectives of the “Smart radio-connected all-in-all wayside objects” Demonstrator**

The objective is to demonstrate solution of object controllers realizing a decentralized approach to rail automation. This approach will be scalable from high performance lines to for regional and freight application. Although modern signalling systems will have considerably reduced trackside equipment, this solution is still relevant, as at least interfaces to points and level crossings will remain, and other necessary interfaces, depending on the specific project requirements.

Today’s field-element controller are designed and developed by each supplier in a different way. They are connected with copper – at least to be connected to the required power supply. The connection to interlocking, RBC and Train Management Systems follows rules and requirements given by railway authorities.

Currently trackside objects are interfaced to control systems in one of two ways:

- a) Where trackside objects are fairly near signalling equipment, tail cables to individual objects are used;
- b) Where trackside objects are geographically distributed, object controllers are placed near the trackside objects, controlling a number of them, with a data link back to the signalling equipment.

There are disadvantages to these solutions:

- It is expensive to provide cabling for power and data to remote trackside objects, especially in freight lines or regional lines featured by poor traffic.
- The cable provided is vulnerable to cable theft, which is costly, and causes disruption.
- Changes within track layouts (position of trackside equipment) are complex and costly.
- The usage of cable restricts distances between trackside objects and signalling equipment which might demands additional signalling equipment (object controller).

An avoidance of all cabling in the field will reduce lifecycle costs of future railway projects significant:

- Material costs
- Installation costs
- Maintenance costs
- Energy costs
- Cost occurring because of cable thefts

A solution where locally derived power and radio communications (or any wireless network communication) together with maximum de-centralisation (up to the level of one Object Controller for every individual trackside object), are used overcomes these disadvantages and meets the Master Plan in terms of improved reliability, enhanced capacity, lower investments, reduced operating costs, improved standardisation and therefor simplified certification / authorisation. Beside the provision of local power supply the challenge for this demonstration project is to provide radio communications to individual remote trackside objects and guaranteeing safety and security justifications.

The innovation of TD2.10 project is to provide fully de-centralized control of remote trackside objects such as points, level crossings, etc., without requiring the use of trackside cabling, and associated cable routes, ducting etc. Additionally the higher band widths will be used for transmission of status reports / maintenance information and further required data.

A cable free connection between objects / machines gets more and more state of the art. Existing devises mostly deal with less safety relevant information / applications. For TD 2.10 we have to assure on the one hand safety and security of data and on the other hand we have to implement energy harvesting systems – which have to be that reliable as it is requested by railway requirements.

A detailed analysis of existing technical solutions / possibilities has to be done at the beginning of the project.

Objectives to be achieved within the project:

- Smart radio-connected all-in-all wayside objects
- Locally derived power supply

- Reduction of power consumptions
- Reduction of required cabling
- Data Exchange with existing and/ or new TMS
- Availability of Maintenance Data

#### **2.5.10.2. Technical ambition of the “Smart radio-connected all-in-all wayside objects” Demonstrator**

The innovation of TD2.10 project is to provide fully de-centralized control of remote trackside objects such as points, level crossings, etc., without requiring the use of trackside cabling, and associated cable routes, ducting etc... Additionally the higher band widths will be used for transmission of status reports / maintenance information and further required data.

The basic idea of a wireless connection between technical devices is known within several industrial areas. Even some singular, specific but non-standardized signalling solutions do exist already. A detailed analysis of existing technical solutions / possibilities has to be done at the beginning of the project.

The novel part is the application of such systems within the safety context of railway signalling systems. Therefore the main risks are about the derivation of safety and security concepts.

It might be possible to use experiences from ETCS projects where a successful standard for the air-gap interface between trackside equipment and trains exists or other solutions available on the market.

The introduction of network connected object controllers will permit the possibility of a direct connection between train carried equipment and the trackside object controllers, for example to report status of the trackside objects to the train. This would, for example, permit the train to react to failure of trackside equipment. A further step would enable the train carried systems to control the trackside object controllers.

This project will also use results from the FP7 Next Generation Train Control (NGTC) project, which includes a Work Package on IP Communications as well as results / inputs and assumptions from other TDs/ IPs.

The TD intends to exploit existing technologies for communications and the outcomes of other TDs. Therefore it is not expected, that this TD will create specific standards or would impact existing ones.

Existing standards (especially safety and security aspect) will be analyzed at the beginning of the project.

**Appraisal of major technical risks and blocking points**

Technical Risk	Description / Mitigation
Energy harvesting solutions do not fulfill safety and security requirements	Without energy harvesting systems copper cable will still be required in the field – whereby the LC-cost saving potential decreases
Data transfer too slow	Data concerning status of the track and field elements have to be transmitted more or less in real time – in case of transmission delays the system would be disturbed / the availability of the system would decrease significantly. Mitigation: Transmission times will be taken as mandatory requirement for each solution
Data connection / transfer do not fulfill safety and security requirements	Without fulfilling these requirements the technical solution would be obsolete. Mitigation: Safety and Security requirements will be taken as mandatory requirement for each solution
Unexpected changes of technical and/ or safety standards and regulations during project (particularly during specification and development works)	New requirements issued by EU and/ or railways are possible. Those might increase or decrease project efforts. Mitigation: Project manager of the TD has to monitor standards and regulations which effect work of TD. Additionally outcomes of interfacing TDs will be monitored and included if necessary
Participants / group member are not delivering their committed contributions and/ or key resources from participants are not available	The required resources are not available. Work packages cannot be handled accordingly. Mitigation: Regular Project meetings combined with reporting structure supervised by Project Manager of the TD. Critical missing deliveries from Participants should be escalated to S2R organisation
Existing licenses and patents might disturb the project	Mitigation: Project manager of TD will evaluate and trace situations of existing patents and licenses which could have effect at the beginning and during the project.
Remark: Most risks can be mitigated by exchange of information / communication in time. Therefore a task was defined: Technical coordination and system engineering, which will help to avoid communication lacks.	

**2.5.10.3. Specific Demonstration activities and contribution to ITDs/SPDs**

To cover the target applications of TD 2.10 following prototypes are discussed, evaluated and defined by S2R members.

An autonomous object controller prototype to interface with ERTMS balises and track circuits on areas far from stations: The object controller will be focused on Maintenance and Data Logging to allow a high availability of the system minimizing the onsite maintenance task.

The object controller will also take into account minimizing the power consumption to allow a remote autonomous operation. The prototype will use secured IP based communications. The work will include the integration of a commercial radio element as part of the object controller.

A multiple object controller prototype, enabling multiple track element management: The scope of the prototype is multiple object management, focusing Track Vacancy Detection (axle counters) & Signals control with safe and secured network communication over external or wireless networks.



Specifically addressing:

- the issues of scalability of the object controller network from small to large-scale area networks;
- Communication between object controllers and to other systems and advanced digital I/O control technologies features.

They will work on hardware of the field elements platform and the implementation of network interfaces, able to cope with different types of communication bearers and different types of energy supply. In terms of software they will work for the base platform, enabling security (close collaboration with TD2.9), providing a safety layer as well as diagnostic functions to satisfy system requirements (close collaboration with TD2.9, TD3.6, TD3.7, TD3.8)

A high efficient controlling of point machines as prototype with:

- advanced diagnostic features of the smart object controller and the point machine;
- specifically addressing the issue of optimised distribution of intelligence;
- very low power consumption of the smart object controller (and requirements on the point machine) with focus on idle mode;
- supplemented by autonomous power supply and storage.

An Interface for IP Communication between Interlocking and trackside objects. This Interface will be able to be integrated into the wayside object, will provide basic fall-back functionality in case of lost communication and will support non-vital data exchange for asset status information.

A prototype of wayside object controller:

- based on a smart routing capability;
- able to manage vertical handover among heterogeneous networks;

This approach also includes the development of a smart multipath router located near the centralized interlocking.

The TRL for all prototypes to be reached is 5 to 7.

Current technical gaps will be covered by Open Calls:

Solution for power supply / energy harvesting

**Beside before mentioned interactions with other TDs/ IPs the following ones are taken into account:**

- IP 2, TD 2.1 Adaptable communication
- IP 2, TD 2.6 Zero on-site Testing
- IP 2, TD 2.7, Formal methods



- IP 2, TD 2.11 Cybersecurity
- IP 2, TD 2.9 Traffic Management System
- IP 1 with regard to “Train Communication”
- IP3 is about cost efficient infrastructure, including the provision of power supplies. Use of “Smart” Object Controllers will help to reduce the initial cost of infrastructure, and to reduce the maintenance costs of infrastructure.

#### **2.5.10.4. Impact of the “Smart radio-connected all-in-all wayside objects” Demonstrator**

Business Benefits as 1st step in Europe as 2nd step worldwide and Key Contribution from the TD2.10:

- significantly lowering the effort for project specific engineering, installation and commissioning;
- minimizing deployment of dedicated data communication cables and instead exploiting existing radio communication systems, public IP network access points or satellite communication systems;
- eliminating the cost for replacement of cables and related services caused by cable theft and civil works impacts;
- using locally derived supply power yielding reduced energy losses via long tail cables and “green up” the transport;
- overall objective is significant LCC reduction (Estimated value 50% in total – for freight and regional lines);
- raising the levels of safety and operational efficiency of signalling systems, while reducing investment costs;
- the maturity of the communication systems as such should be very high: TRL 5-7 (The degree of maturity is strongly dependent on the outcomes of other TD, which will be implemented inside the Object Controller which are e.g. the communication solutions, cyber security, and of the advances made in the locally derived power supply technologies).

Measurable quantities are life cycle costs:

- basic invest – costs of cabling and material;
- installation costs – complexity, expenditure of time, required man power;
- maintenance cost (taking into account new hardware configuration as well as new functional possibilities with data exchange with TMS), MTBR, MTBF;
- cable theft;
- engineering efforts.

### 2.5.10.5. Implementation of the work programme

The methodology for TD 2.10 is outlined in Figure 54 and Figure 55.

Figure 54: System overview of TD 2.10

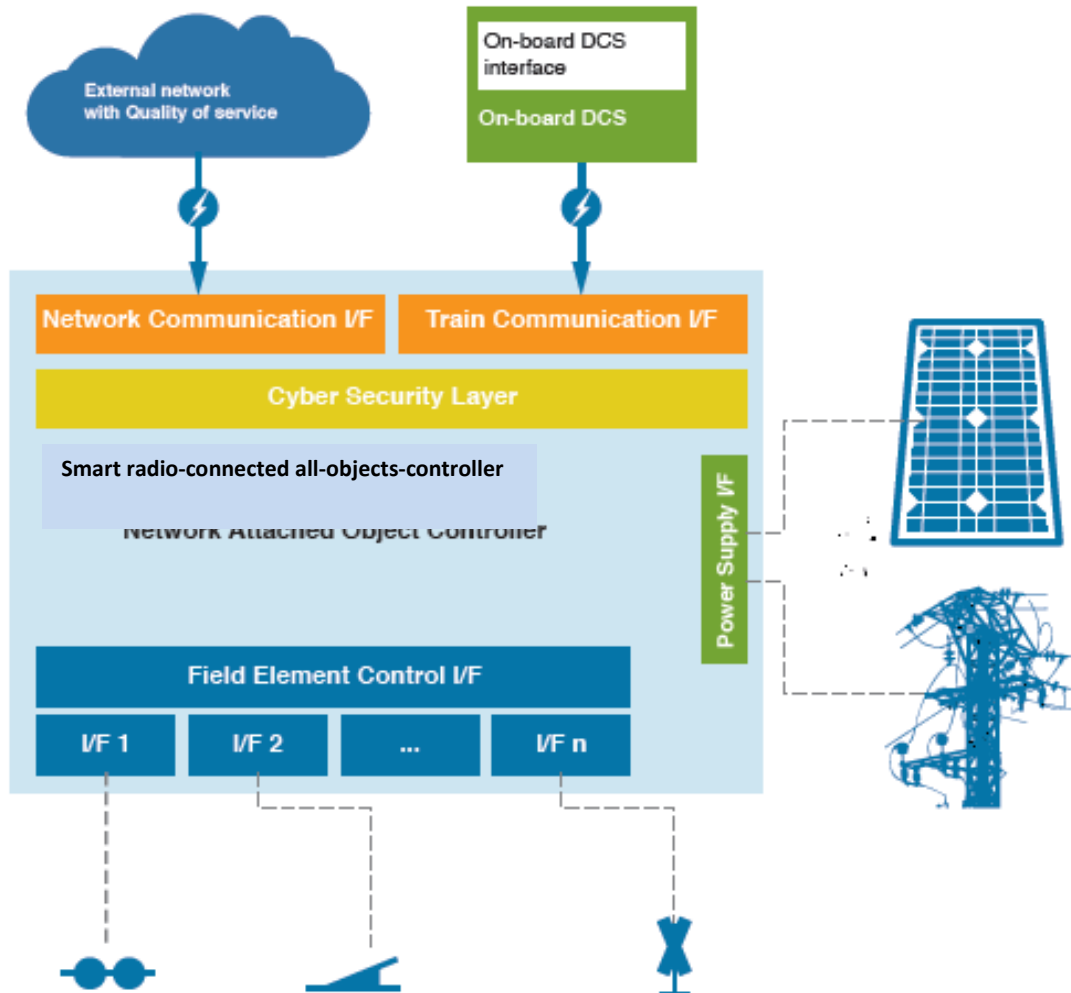

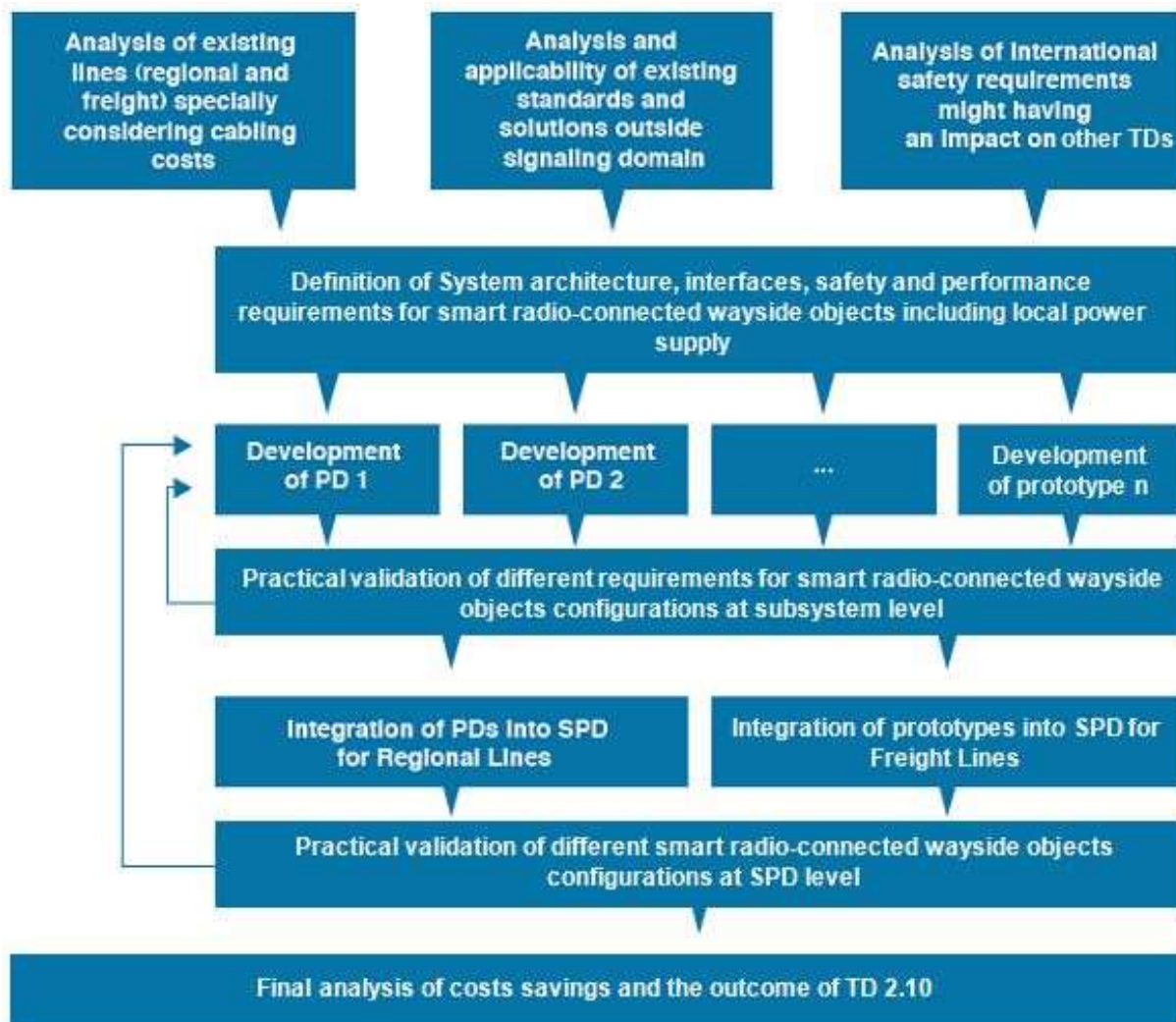
**Figure 55: Workflow****Description of work packages:****Task 2.10.1: Analyses of existing lines and economic models:**

TD 2.10 will provide economic models and analyses.

Within this task the S2R members will:

- focus on special requirements of regional and freight lines;
- analyze the state of the art of communication techniques as well as technical possibilities within power supply area. Regarding this issue it will be relevant to have a look to two aspects: Local power supply and reduction of power consumption of the field-elements itself. The results of all analyses will be documented and reported accordingly.

Open Call – further expertise will be needed to cover power supply models. Additionally consultants and/ or economists might support summarizing all facts and information to enable S2R members to have a common view on the market and its trends.



#### **Task 2.10.2: Analyses of railway requirements / standards:**

Within this task railway requirements will be analysed by S2R members with regard to safety, security and performance issues. Relevant results will be documented, summarized and reported. Together with the analyses of existing lines a common base for further steps will be assured.

The S2R members will seek the expertise of experts in international railway regulations to get the best possible background for the task. The background is mandatory to lead the project as well as the prototypes in the right direction.

During this task a regular information exchange with other TDs (e.g. 2.1, 2.6) is required.

#### **Task 2.10.3: Definition of system architecture:**

The system architecture will be defined and document rough overall system architecture.

The S2R members will seek in this task the support of experts coming from universities and/ or the industry (beside the knowledge about railway industry the supporting entities should be specialists in radio communication and power supply / energy management).

Within this architecture the interfaces between object controller, communication network and adjacent systems (e.g. interlocking) will be defined. Based on the requirements and standards evaluated in precedent tasks, the communication network(s) will be pre-designed accordingly. Pending on the requirements those networks are based on (adapted) existing components or new developments.

Beside object controller and networks TD 2.10 will figure out requirements on local power supply / energy harvesting. Possible solutions will be pre-designed. Similar to the communication network there might be existing solutions which have to be adapted or new solutions have to be developed.

Another outcome of this work is a structured planning on the overall TD 2.10 system demonstrator (integrating later on developed prototypes or simulations). The planning will include a system-definition, schedule, milestones and responsibilities.

This work will be performed by S2R members. The out coming results are base for next work packages. Also during this task a regular information exchange with other TDs (e.g. 2.1, 2.6) is foreseen.

#### **Task 2.10.4: Development and verification of PDs (Prototypes):**

The objective of that task is to develop prototypes following the specification, to define the tests to be done and to provide the Lab test report. Prototypes are defined in chapter “Specific Demonstration activities and contribution to ITDs/SPDs”.

First, defined rules and requirements will be validated. In the second step the prototypes will be developed and verified taking into account the real environment for testing.

The development task should be assisted by specialists on local power supply generation, energy harvesting, energy storage, radio communication modules, high efficient power supply, remote diagnostics, low voltage electronics, to build on previous experiences.

The prototypes will take into account performance requirements in line with RAMS expectations, cyber security and local power supply.

**Task 2.10.5: Validation (incl. Integration and Validation at SPD Level – paperwork at P1 / real integration P2):**

Validation will be executed according to test and validation plans.

**Task 2.10.6: Optimisation Works**

The results of the validation phase will serve as an input for optimizing prototypes.

**2.5.10.6. Planning and budget:**

IP	TECHNOLOGY DEMONSTRATOR	TASK	TRL	2016	2017	2018	2019	2020	2021	2022	2023	2024
IP2	TD2.10 Smart radio-connected all-in-all wayside objects	task 2.10.1 Analyses of existing lines and economic models	2	■								
		task 2.10.2 Analyses of railway requirements / standards	2	■	■							
		task 2.10.3 Definition of system architecture	3		■	■						
		task 2.10.4 Development and verification of PDs (Prototypes)	5-7				■	■	■			
		task 2.10.5 Validation	5-7						■	■		
		task 2.10.6 Optimization Works	5-7								■	

Estimated budget of the TD (including EU funding and Open Calls): 12.5 M€.

**2.5.11.TD2.11: Cyber Security**

**2.5.11.1. Concept and objectives of the Cyber Security Demonstrator**

**Introduction**

Nowadays the wired and wireless networks used by railways operators are usually heterogeneous, not protected well enough and they don't fulfil the usual cyber security requirements in term of sustainability, protection and attack detection.

Some communication channels have already been standardized (e.g. EVC-RBC or RBC-RBC connections) but the solution doesn't seem to be flexible, cost effective and sustainable because of the use of cryptographic techniques for which the obsolescence has already been planned and because of the amount of manual maintenance operations (the update of the encryption and authentication material still requires the manual intervention of operators on trackside and mobile devices). The quick evolution of the telecommunications means, the threats and the sustainability aspects have not been taken into account.

There are many devices and rooms which are not secured. The access protections to trains and shelters are usually mechanical (keys, padlock or even a common key for many devices...). The profile selection is usually very poor and when this feature is provided it is usually based on the user name.



The current solution is not sustainable in the long term due to:

- its high maintenance cost;
- its lack of flexibility, upgradability and interoperability;
- its weakness in term of protection and detection.

The main goals of the security system as framework of IP2-TD2.11 are the following:

#### 1. Security and safety improvement

Applied to the railways system, the main objective of the security system is to ensure high availability, authentication and integrity of the railways system by preventing attacks or errors. The railways system is a safety-related system and safety highly relates to security. Safety cannot be ensured in case of lack of security.

As most of the railways devices are computer-based, this security mostly focuses on computer and network security, called 'cyber security'.

The cyber security addresses:

- the protection of data against unauthorized disclosure, modification, or destruction;
- the protection of the computers against unauthorized use, modification, or denial of service;
- the protection of the railway IT network against attacks and malicious acts.

But, more widely, the security applied to railways also addresses the buildings, the infrastructure and the trains. Improving the security in the European railways also implies a more controlled and restricted physical access.

#### 2. Cost reduction and standardisation

The second goal is reducing the infrastructure and maintenance costs of railways operators and improving compatibility and interoperability by standardizing the security system at European level. This will apply to all new ICT used in railway (e.g.: traffic management, interlocking, Urban signalling communication, ...).

**Technical output to be delivered by this TD:**

1. Output 1: Definition of a security system dedicated to railways: This security system is intended to be comprehensive, easily sustainable and integrated/interconnected.
2. Output 2: Application of the methodology to railways: Define and develop demonstrators of railways applications based on methodology defined in objective 1 that ensures infrastructure, train and communication protections.
3. Output 3: Develop a network of Railway Cyber Security Experts (CERT): Besides the two main objectives presented here above, this third one concerns the development of a network of security experts in the railways community. This network would be the basis of a CERT (Computer Emergency Response Team) dedicated to railways.

**Specific achievements to be delivered by this TD:**

Field	Cyber Security Demonstrator
Standardisation	Standardised Cyber Security System (CSS) that could be applied to all interfaces.
Security	Provided through a strong, upgradable and standardised CSS and through the definition of standardised secure design method.
Deployment and maintenance cost	Low due standardised CSS and protections means.
Sustainability in degraded situation	Very high due to the development of the CERT, the implementation of the CERT environment, the specification of the disaster recovery management plan and of the related workflows.
Access protection and profile management	Remote and secured access protection. Dynamic profile management. Attack detection tool implementing behaviour adaptation

The following table shows how the proposed activity will contribute to the achievement of the S<sup>2</sup>R objectives as stated in the S<sup>2</sup>R Master Plan:

**Table 17: Objectives and deliverables**

S <sup>2</sup> R Objectives	TD Objectives	Desired outcomes
Improved services and customer quality	Improved reliability	Quality of service is enhanced due to the specification of a more robust and controlled network. This will prevent any unavailability due to unauthorised access, external perturbations, denial of service attack and by early incident detection and localisation.
	Enhanced security	Security of the railway system is improved through: a significant improvement of the network monitoring the development of applications and products respecting the cyber security profile and development processes. a capacity of self-adaptation to user and system changes. This will have an impact on the complete system availability and security.
Reduced system costs	Improve reliability	The improvement of the system reliability has an impact on cost operation.
	Installation of cryptographic key	One of the targets of this TD is also to reduce in a drastic way the time needed to exchange cryptographic information between operators (reduced by 99%). This will increase the railway availability for “cross-network” operations
Enhanced interoperability	Specification of a common solution	standardisation of design methods, interfaces, architecture and protocol will allow using standardised system and maintenance tools rather than out-dated and specific technology, with significant impact on installation and maintenance cost due to competition and standardisation. The definition of a common solution will allow also easy system interconnections.

### **2.5.11.2. Technical ambition of the Cyber Security Demonstrator**

#### **State of the art in the railway transport**

The railway infrastructure mostly relies on computer-based devices which are interconnected through wired or wireless networks, making the railway transport vulnerable to cyber-attacks. The railway infrastructure is highly distributed, thus difficult to protect, and it has been built before having had to deal with threats and risks to sensitive data networks. Above that, every country has its own infrastructure, its own networks and every operator has its own strategy regarding cyber security.

However some encryption protocols have already been standardized but their application is restricted to particular ETCS interfaces: EVC-RBC wireless communications and RBC-RBC communication. These standardised protocols are based on the prerequisite distribution of symmetric keys to all communicating entities. The process of installation/update of these keys in trains or trackside devices requires the manual intervention of an operator on site, leading to high



maintenance costs and hardly reducing the global security level of the system. The protection of other railway communication channels is not addressed by these protocols and is managed on a case-by-case basis.

The following figure illustrates the distribution and exchange of ETCS authentication keys inside domains and between foreign domains. Subset-038 of TSI specifies how keys are exchanged between domains and subset-114 specifies how keys are distributed inside a domain to RBCs and trains. Both distribution and exchange are done off-line.

**Figure 56: Exchange channels for authentication keys**

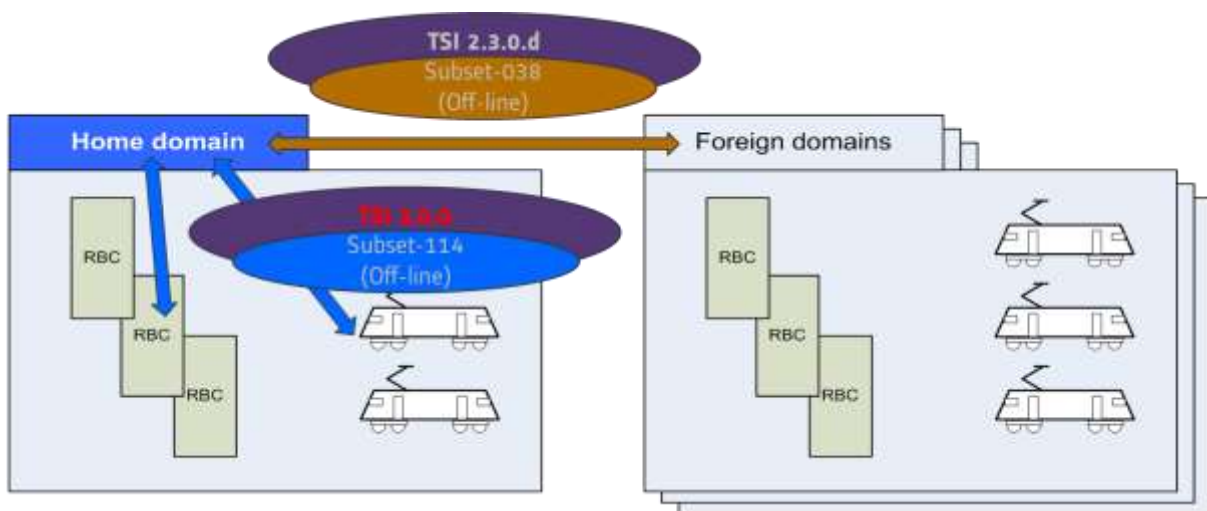

In the following years, an initial improvement of the key management system will be introduced by the adoption of a common standard for the on-line key management.

Regarding security assessment, preliminary joint threat analyses have been performed by the ERTMS user group. Such initiative has not yet led to common approaches, requirements or policies for cyber secure railway signalling system; each operator having its own standard and policy. This lack of standardisation is a major impediment for the development of cyber secure signalling system. This is even more critical due to the long life and development cycles of the signalling systems.

Regarding the access control, there are still many devices and rooms which are not access-restricted and some access protections to trains and shelters are still mechanical and use standard keys (a driver's cab is usually accessible through a standard mechanical key). When access control is implemented, there are only two categories of profiles (access is simply allowed or not) and no intermediate categories are provided.

Security in railways system has also been addressed by the PROTECTRAIL-project. The objective of the PROTECTRAIL-project was to provide a viable integrated set of railway security solutions, by considering:

- the extent of the assets involved,
- the nature of the possible threats,



- the amount of technical requirements and operational constraints.

PROTECTRAIL developed mission oriented solutions vs. asset-specific threats and made them interoperable by designing a modular architectural framework where each solution can be “plugged” in and also provided the basis for a streamlined process of federation, integration and interoperability of the developed solutions.

The project ensured that appropriate solutions and innovations are favoured over isolated questions and solutions, and presented a comprehensive and scalable answer to overall rail security. The assumption made is that on this frame of solutions, each railway operator in Europe should be able to compose its integration of existing technological tools by using the same architecture according to its own needs, requirements and budget, and subsequently assess the security potential of the solution.

In the course of this project, protection of communication and information systems was viewed on a higher, abstract level defining a global strategy which serves as an initial point for the tasks targeted in the Shift2Rail-project concerning IT-security.

The European project SECRET has also highlighted the vulnerability of the railways regarding the jamming of the signalling, localisation and communication information. This project has:

- identified physical parameters which can be monitored to efficiently detect attacks on communication channels and on localisation signal (i.e. GPS);
- developed jamming detector sensor prototypes for communication channel and localisation signal;
- developed concept of resilient network architecture.

Given the lack of guidance to assist the implementation of cyber security measures suitable to public transport, the European project SECUR-ED defined a common reference for implementation of cyber-security by any public transport operator.

The SECUR-ED project defines:

- A comprehensive framework of assets, architectures and technologies used by the public transport operators;
- A set of security standard and regulation that may be applicable to public transport operators;
- A baseline for the security requirements;
- An implementation approach for cyber security measures.

Project	Input
UNISIG Subset-037 of TSI standard (2000)	Euroradio FIS (defines the Radio System Interoperability for message exchange between on-board and trackside equipment).
UNISIG Subset-038 of TSI standard (2000)	Off-line Key Management FIS (Functional Interface Specification for the KMC-KMC interface).
UNISIG Subset-098 of TSI standard (2007)	RBC-RBC Safe Communication Interface (Form Fit Functional Interface Specification for RBC-RBC connection)
UNISIG Subset-114 of TSI standard (2012)	KMC-ETCS Entity Off-line KM FIS (Function Interface Specification for the interface between the Key Management Centre (KMC) and the trackside and on-board ETCS equipment inside a key management domain).
4th call of the TEN-T programme: UNISIG Subset-137 (end-2015)	KMC-ETCS Entity On-line KM FFFIS (Fit For purpose Function Interface Specification for the interface between the Key Management Centre (KMC) and the trackside and on-board ETCS equipment).
PROTECTRAIL-Project (2010 – 2013)	Development and test of a viable integrated set of railway security solutions.
SECUR-ED Project (April 2011 –September 2014).	Definition of a common reference, guidelines and recommendations for implementation of cyber security by public transport operators.
SECRET Project (2012-2015)	Identification of physical parameters which can be monitored to efficiently detect localisation and communication signal jamming. Development of sensor and resilient architecture prototypes.

A special attention has to be paid to the integration of the new on-line Key Management System specified by UNISIG in the Cyber Security System. This integration will allow the assessment of the match between the current UNISIG standard and the future Cyber Security System and to identify potential improvement, if any.

### **Evaluation of benefits of CSS**

#### **Implementation cost reduction**

Definition of railway cyber security system will allow the use, in a secure way, also public or non-proprietary network for railway applications. A new application could not need a proprietary or specific telecommunication system; one can design a general-purpose network using standard components, or even reuse an existing network, with obvious cost benefits.

By defining standardised and secure interfaces, architectures and networks, new applications will be easier and quicker to design, implement and test.

The proposed access control system allows the use of the same physical devices (e.g. smartcard and card reader) in the whole system, for many different functions. In addition, management of access rights and profiles can be centralized; a single centre could serve a wide geographical area – even the whole country.



### Security improvement

Cyber security will provide new functions / features, such as threat detection, which are currently missing in the communication channels between devices inside the railway systems.

As a result, the security level of those communication channels will be improved; whether they already have security measures (e.g. RBC-RBC or RBC-train protocols, with cryptographic techniques and authentication) or not (legacy or proprietary protocols, which can't be modified).

The collaboration among CERTs will allow to quickly spread knowledge about a new threat (e.g. for a new kind of virus: which machines can be attacked, what kind of damage could be done, what countermeasures can be used). This way the other CERTs can gain enough time to render the threat less disruptive – or even not effective at all, thus greatly increasing the overall security level.

Protocol standardisation will allow the specification of different monitoring functions, cryptographic techniques and / or key lengths. Should a given technique become not reliable anymore, one only needs to choose a newer / better technique supported by the involved entities. No modifications to “application” logic is required, nor specific testing to that particular technique.

The global level of security in the railways system will also be improved by the new proposed access control system. The identity of every person trying to access any device or room will be checked, and any attempt will be logged; access will be given or refused depending on predefined profiles and associated access rights. The definition of access rights can be very detailed and there can be a wide variety of profiles. In addition, when an access right is not reliable anymore (e.g. a smartcard has been stolen) its revocation is quick and has an immediate effect. An additional security level will consist in ability to detect intrusions and external threats from abnormal behaviours and functioning drifts.

The centralisation of the user profiles and access rights definition should lead to a better global organisation and an easier access to other sections of infrastructure (e.g. from a country to another one).

### Providing integrated IT system network across Europe

By defining standardised and secure interfaces, information exchange among different countries will be greatly simplified.

This will allow a better integration of existing services at European level, as well as the development of new applications. Passenger information system, for example, can greatly benefit from this integration.

### Maintenance cost reduction

The ability to use in a secure way many different networks (also public or non-proprietary) will allow automation of many different applications, with obvious benefits in maintenance costs.

One example is online key distribution, where significant cost reduction can be achieved, as on-site interventions to install or update these keys won't be needed anymore.



Another example is low traffic lines, where manual operations are required now. These could be eliminated, greatly reducing costs, by using an already existing telecommunications system (or deploying a new one).

Important cost reductions will also result from the security protocol standardisation. The global management of keys will be much easier, since all devices meet the same requirements. Standardisation and flexibility will also simplify change management: as different kinds of encryptions / different key lengths will be defined and supported, it will be possible to enhance the strength of a protocol with a minimum effort.

With the new proposed access control system, the following maintenance aspects are greatly simplified, with a consequent cost reduction:

- the number of “physical devices” to be created and distributed (e.g. a key or a badge) is reduced: the same smartcard can grant access to different functions / structures.
- Granting a new access or revoking an existing one requires just an update of the profile. There’s no need anymore, for example, to change a lock when the key is lost / stolen.
- Staff needs to learn only one general access procedure, and to remember (and keep updated) only a few passwords. In the same way, the same procedure to inspect / compare access logs applies to different functions / structures.

The impact of copper cables thefts will also be significantly reduced since the damaged zones will be automatically located. The time interval during which the train services are disrupted across the country and the maintenance costs will be reduced.



## **Benefit summary**

**Table 18: Comparison between state-of-the-art and future**

Field	State-of-the-art of railway network	Cyber Security System
Standardisation	No standardisation at European level except for ETCS	Standardised CSS that could be applied to all interfaces.
CSS integration	No integration	Integrated network at European level.
Security	The protection of most of the network is weak (when the network is protected) and not standardised, except for the interfaces standardised through ERTMS.	Provided through a strong, upgradable and standardised secured network.
Deployment cost	High due to the diversity of networks and protection means	Low due standardised CSS and protections means.
Maintenance cost	High due to the diversity of network and to the significant level of manual operation to be performed on-site	Very low due to the standardisation of the CSS and of the automation and remote management of maintenance operation
Sustainability in degraded situation	Very low due to the diversity of the network and the lack of coordinated incident or disaster recovery management plan	Very high due to the development of the CERT, the implementation of the CERT environment, the specification of the disaster recovery management plan and of the related workflows.
Access protection and profile management	Access protection only mechanical and no profile management	Remote and secured access protection. Dynamic profile management.

### 2.5.11.3. Specific Demonstration activities and contribution to ITDs/SPDs

The following table summarises the contribution of TD2.11 cyber security to the different ITDs of Shift2Rail:

Research Area	Specific Techn. objective	Specification Activities?	Demonstrator		Focus of activity
			Market	TRL	
Cyber Security	Secure Network	Architecture and protocols	Metro	6/7	After security assessment of existing solutions and of the telecommunication network, standardised interfaces, monitoring functions, protocol and architectures for secure networks have to be specified. Efficiency and robustness of the standardised solution has to be demonstrated through a technical demonstrator.
			High Speed, mixed traffic lines, urban/suburban	6/7	
	Secure railway application	Cyber secure design standard and protection profiles	Metro	4	After having identified protection profiles dedicated to railway applications and design cyber security standard applicable to railway development, demonstrate their applicability through access and profile management railway applications.
			High speed, mixed traffic lines, urban/suburban	6/7	
	Develop a network of Railway Cyber Security Experts (CERT)	Define holistic knowledge database. Specify CERT model for railway	High speed, mixed traffic lines, urban/suburban	5	After having defined a common understanding of cyber security matter for railway, including the definition of a common “language”, specify CERT model for railway and develop a prototype of the CERT railway environment.

The following table summarises the interactions of TD2.11 cyber security with other TD’s of IP2:

TD	Interaction
TD2.1: “Adaptable communications”	<ul style="list-style-type: none"> <li>• The adaptability of the communications is one of the aspect that has to be considered also at CSS level;</li> <li>• Cyber security needs will be considered for the definition of the solution for the TD 2.1</li> </ul>
TD2.4: Fail-Safe Train Positioning (including satellite technology)	Services provided by the TD2.11 will allow to detect the jamming of the satellite signal and to trigger countermeasures.
IP2 – TD2.6: “Zero on-site testing”	Services provided by the TD2.11 will facilitate the remote testing between labs
IP2 – TD2.7: “Formal methods and standardisation for smart signalling system”;	Use of formal specification for cyber security standard has to be considered.
IP2 – TD2.10: “Smart radio-connected all-in-all wayside objects”.	Cyber security needs will be considered for the definition of the solution for the TD 2.10.

The TD2.11 will also strongly interact with IP1 and IP5 (for the fitting into a vehicle, respectively for High Speed, Intercity or Freight types of rolling stock) and with IP3 (for the infrastructure part and any interfaces there).

#### **2.5.11.4. Impact of the Cyber Security Demonstrator**

##### **Expectation for exploitation and possible market uptake**

By the end of the proposed work, all the principal elements required for rapid market uptake after the Shift2Rail have been taken into account in this proposal.

These are:

- Common an standardised architecture, interface and protocol specifications for interoperable railway network;
- Common up-to-date Cyber Security approach for railway network and application;
- Investigation and monitoring tools dedicated of the railway Cyber Security System;
- Setting up of Railway CERT;
- Prototype of collaborative environment dedicated to the Railway CERT.
- Prototype of Railway products/applications using the Cyber Security System for access protection, communication securing.

As stated in the previous sections, the state-of-the-art of railway Cyber Security System is clearly lagged behind compared to what is done in the other fields using CSS (e.g.: banking, telecommunication, Web industry, ....). This backwardness is no more sustainable and it becomes urgent to resolve it.





### **Contribution to TSIs and standards**

The objective “Guidelines for development and implementation of a railway cyber security management system” consists of elaborating and specifying architectures, interfaces and protocols that railway devices should comply with.

The outcome of this task is then a document containing specifications and guidelines for a railway cyber security management system (RCSMS). The draft version of this document is planned to be submitted to European Standardisation Organisations (ESOs) for integration into existing railway standards.

The objectives related to the railway CERT definition and specification aim to define CERT models and glossary dedicated to railways. The draft version of this document is planned to be submitted to European Standardisation Organisations (ESOs) for integration into existing railway standards.

### **KPI Impact on Shift2Rail targets and market**

The current TD participates to the 3 targets as follows:

#### **Reduce LCC:**

The current TD will have an impact on the Life Cycle Cost at different levels:

- Operational and security level:
  - Early detection of incident due to network supervision and quick reaction due to incident management plan will reduce the cost impact of IT incidents;
  - Use of a protected network will prevent from external attack with huge impact on operations and corporate image.
- Installation and maintenance level:
  - the cost of the management of the cryptographic information is expected to be reduce by at least 96%;
  - standardisation of interfaces, architecture and protocol will allow using standardised system and maintenance tools rather than out-dated and specific technology, with significant impact on installation and maintenance cost due to competition.
- Design and development level:
  - Adoption of cyber security common standards for design and development will reduce in a significant way the development and certification costs and will allow to provide cyber secure COTS products.

#### **Raise the railway availability:**

The implementation of a supervised and secured network will allow early incident detection and localisation. This will reduce in a very significant way the time needed to put back in service the operations.

**Strategic impact**

Strategic Aspect	Key Contribution from the TD
Support the competitiveness of the EU industry	The European railway security system should encounter the same success as the European train control system, since it offers the same standardisation and interoperability advantages. Railway companies implied in the elaboration of this common security system will add a significant feature to the solutions they currently propose and the implied European companies specialized in information security will find new applications and new markets for their products.
Compliance with EU objectives	The European objectives are met since IP2-TD2.11 globally contributes to the availability and safety of the European railway traffic and since the development of a common and standardized solution is one the main objectives of IP2-TD2.11.
Degree of maturity of the envisaged solutions	Cyber-security technologies are considered as mature even if in constant evolution. Actions taken to apply them to railways networks are quite recent and defining the way to do it has still at the beginning.

**2.5.11.5. Implementation of the work programme****Overall strategy and general description**

The vision developed by the TD is to propose at the dawn of the next decade a comprehensive, standardised, upgradable and secure Cyber Security system with associated standards, tools and workflows that will ensure its protection to future and unknown threat and its sustainability.

This will be done by applying and adapting to the railway needs the up-to-date Cyber Security technics already applied to other leading sectors in cyber Security.

This will represent a revolution of the Railway Cyber Security.

**Methodology**

Completion of the vision and objectives can be broken down into the following main activities.

Three types of activities can be distinguished:

- Activities of theoretical analysis and definition of rules and standards.
- Activities of development of demonstrators applying these rules and standards to the railway applications and networks.
- A third type of activity addressing the organisation of the cyber-protection at international level (definition of roles, actions to be taken by people).

In the first phase of theoretical analysis and definition, following tasks will be started in parallel:

- A deep analysis of the main railway networks and applications in order to point out all current vulnerabilities, specific needs, threats and risks. The results of this analysis will be used to feed back the tasks of definition and specification that will have been started in parallel.



- The definition of principles and guidelines to follow in order to implement threat detection and prevention in the IT networks and applications used by railways and the classification of all possible incidents and, for each one, which countermeasures need to be applied. It will be performed on a recursive way since it uses the results of the security assessment started in parallel.
- The specification of architectures, protocols, design standards and interfaces that all communicating system in the railway system have to be compliant with, in order to secure the railway system against cyber-attacks. It will also be performed on a recursive way to take into account the results of the security assessment. This is the aim of objective 1.3.

Knowing that the cyber security is a sensible subject for some years for some of the operators involved in S<sup>2</sup>R, any analysis already performed by one of the members in the last year could be used as input.

Once the preliminary results of the analysis and definition phase are available, the phase of building demonstrators will be started.

- A first demonstrator or a first class of demonstrators (CSS network demonstrator) will implement the threat detection, prevention functionalities and incident management processes, on networks providing all types of interfaces required by the railway applications.
- In parallel with the development of the CSS network demonstrator, a second demonstrator focusing on the specific railway applications complying with the standards defined in the 1<sup>st</sup> phase, and based on or integrating the new features brought by the CSS network demonstrator (railway application demonstrator).

The 3<sup>rd</sup> phase is the definition of a complete terminology and taxonomy, the creation of an R-CERT and the development of a demonstrator for a collaborative CERT environment with real life CERT-partners.

### **Description of Tasks**

The S2R members represent most of the provider of the railway signalling system in Europe as well as major railway operators.

Further expertise might be needed from open calls, in order to complete the TDs ambition. Cyber security being quite a new subject for railways, external expertise will be required in order to fulfil all tasks of the TD.

Expertise is needed in the following cyber security fields:

- IT network: expertise is needed in security assessment, threat and intrusion detection, network design;
- Cyber secure design process: expertise is needed in the cyber secure design standard and processes;
- Computer Emergency Response Team organisation;

- Railway, transit operators.

### **T2.11.1 Definition of a cyber-security system dedicated to railways**

This task consists in specifying and developing a prototype of a cyber-security system (protected network providing cyber secure interfaces) dedicated to railways.

#### **-Sub-Task T2.11.1.1 (TRL 3): Security assessment limited to ETCS and CBTC system**

This sub-task consists in performing a cyber-security assessment of an operational ETCS and of a CBTC system.

As part of this task, a survey of the current cyber security policies in European railways and of the recommendations resulting from previous European projects (SECUR-ED) will be performed in order to establish a catalogue of the best cyber security practices in railway.

Human factor has to be addressed in the risk analysis.

S2R members will perform the survey and security assessment. They will provide the needed information to define the context of use of the signalling system and to identify the major concerns related to the application of cyber security to railways. Human factor specific risk analysis will also be performed.

#### **- T2.11.1.2 (TRL 3):Threat Detection, Prevention and Response for ERTMS and CBTC**

This sub-task consists in identifying and analysing the different cyberattack risks applicable to railway and transit systems. For each identified cyber-attack risk, assessment of the implementation complexity and mitigation proposal has to be performed.

Based on the outputs from the “secret” project, a special attention will be paid to the potential threats against the wireless connections used for communication or localisation purposes.

The S2R members will:

- perform the identification of threat, and cyber-attack risks.
- propose mitigation and perform implementation complexity analysis.
- Apply situation Awareness assessment method to the signalling system.
- define the specifications for detection system, defence tools and dynamic network reconfiguration tools
- provide the needed information to define the context of use of the signalling system.

#### **- T2.11.1.3 (TRL 3):Guidelines/standards limited to standardised systems (ERTMS + CBTC)**

This sub-task consists in defining the architectures, protocols, interfaces and procedures to be applied to all communicating entities across the networks dedicated to signalling systems and railways infrastructure taking into account the “human(s) in the loop” behaviour if needed.



The S2R members will:

- Write the standards and guidelines;
- Provide the needed technical support and recommendations for specification;
- perform an assessment of the safety impact on the railway signalling system of the proposed solution according to EN railway standards.
- perform an assessment of the match between the current UNISIG on-line KMS standard and the Cyber Security System requirements, identifying potential lack of immunity and consistence and proposing steps for improvement.

- T2.11.1.4 (TRL 4 to 6/7): Technical demonstrator.

This sub-task consists in specifying and implementing cyber security technical demonstrator.

The S2R members will:

- specify and implement a module of the Technical Demonstrator on the basis of a identity management (IdM) approach, allowing to cope with lifecycle spanning processes such as commissioning, operation, maintenance, redefinition, etc. The IdM approach tackles the complex life cycle management of long living components' identities across multiple versioning and dependencies in rail environments while protecting the confidentially issues of identities. This module will be developed and implemented in lab environment;
- define and develop an Intrusion Detection System (IDS) implementing innovative attack detection algorithms based on monitored parameters (at physical and logical levels) and indicators defined in TD2.1.1.2;
- analyse and propose additional monitoring or supervision tools or processes to identify, capture and protect the network from known and unknown attack vectors.

**TD2.11.2: Application of the cyber-security methodology to signalling system:**

This task consists in specifying protection profiles and cyber security standards applicable to railway application and in demonstrating their applicability in a technical demonstrator.

This task is composed of the following sub-tasks:

-TD2.11.2.1 (TRL 3): Define profile protection, cyber security standard to be used and the assurance level requested for railway applications.

The S2R members will:

- identify and specify the protection profile, design cyber security standards and the requested assurance level for railway signalling applications (product and sub-system).
- *define* cyber-attack barrier requirements for protection profile.



- define the protection profile and to the selection of the cyber-security design standard to be applied for the network part.

Open calls might be used to Provide support and expertise for the sub-task. Essential need of cyber security experts in design cyber security standards and processes applicable to products (HW and SW) and sub-systems.

-TD2.11.2.2/3 (TRL 4 to 6/7): Infrastructure access protection (station level) + profile remote management;

The S2R members will:

- Implement infrastructure/train access protection implementing remote access protection, remote access right management and role based access control. This application is used as demonstrator of the design cyber security process defined in the sub-task TD2.11.2.1.
- provide a video and audio system for detection and monitoring of access to controlled space.

Open calls might be used to provide support for design cyber security standards and processes.

-TD2.11.2.4 (TRL 4 to 6/7): Demonstrator limited on On-board-Trackside or trackside-trackside application

The S2R members will:

- Implement railway applications, compliant to cyber security design standards, on the cyber security system demonstrator defined in TD2.11.1 (e.g. ATP application).
- define and set up of attack scenario use cases to evaluate system behaviour on the CSS defined in TD2.11.1.

Open calls might be used to provide support for design cyber security standards and processes.

**TD2.11.3: Develop a network of Railway Cyber Security Experts (CERT)**

Expected participation needed in this task would include already established CERT for national/international authorities or company/research centre specialised in CERT design.

This task consists in specifying CERT common model and language and in developing a prototype of the CERT environment.

CERT has never been considered in railway and support is *definitively needed* to implement such cyber security survey mechanism. Needed skills could come from cyber security research centre or already existing national CERT.



This task is composed of the following sub-tasks:

- TD2.11.3.1 (TRL 2): Combining expertise – Designing a holistic knowledge base

The S2R members, in order to set up a working CERT environment, both railway representative and cyber security experts, will have to work together closely and set up a common understanding, including a common “ontology”.

Open Calls might be needed to select experts specialised in CERT, notably to lead this task.

- TD2.11.3.2 (TRL5): Prototype of CERT model dedicated to railway:

S2R members will:

- provide support and needed information to define the CERT model;
- participate to the identification of information sources, to the capture of network architecture and to the analysis of the sub-system dependencies.

Open Calls might be needed to select experts specialised in CERT model needed to formalise the model design.

- TD2.11.3.3 (TRL 5): Prototype of CERT collaborative environment

S2R members will:

- review and validate the CERT environment prototype;
- Provide internal CERT expertise to set up a distributed environment and leverage the specific expertise from all parties.

Open Calls might be needed to select experts specialised in CERT environment design needed.

Open Calls might be needed to select experts to define and implement prototype of CERT collaborative environment.

### 2.5.11.6. Planning and budget:

TECHNOLOGY DEMONSTRATOR	TASK	TRL	2016	2017	2018	2019	2020	2021	2022	2023	2024
TD2.11 Cyber Security	task 2.11.1 Def. A Cyber Security system for Railway										
	Subtask 2.11.1.1 Sec. Assessment or ERTMS and CBTC	3									
	Subtask 2.11.1.2 Threat Detection, Prevention and Response for ERTMS and CBTC	3									
	Subtask 2.11.1.3 Guidelines/standards limited to standardised systems (ERTMS + CBTC)	3									
	Subtask 2.11.1.4 Technical demonstrator	6/7									
	task 2.11.2 Application of the cyber-security methodology to signalling system										
	Subtask 2.11.2.1 Define profile protection, cyber security standard to be used and the assurance level requested for railway applications.	3									
	Subtask 2.11.2.2 Infrastructure access protection	6/7									
	Subtask 2.11.2.3 Train access protection	6/7									
	Subtask 2.11.2.4 Demonstrator limited on On-board-Trackside or trackside-trackside application	6/7									
	task 2.11.3 Develop a network of Railway Cyber Security Experts (CERT)										
	Subtask 2.11.3.1 Combining expertise – Designing a holistic knowledge base	2									
	Subtask 2.11.3.2 Prototype of CERT model dedicated to railway	5									
	Subtask 2.11.3.3 Prototype of CERT collaborative environment	5									

Estimated budget of the TD (including EU funding and Open Calls): 12.5 M€.

## 3. IP3 – Cost Efficient and Reliable Infrastructure

### 3.1. Context and motivation

The next 20–30 years will see unprecedented demand for growth in transport. European railways have to deliver increased productivity to fulfil growth demands across all modes in freight and passenger services by 80% and 50% respectively by 2050. The Shift2Rail Innovation Programme 3 (IP3) focuses on innovative design and optimisation of core infrastructure elements as well as improvement in the management of the railway system by adopting a holistic, system-wide approach. The focus will be on priority research areas as identified later in this section.

The European railway network has been incrementally developed over many years and is, too often, a patchwork of components, sub-systems and localised improvements. Railway networks are in general non-optimised and susceptible to performance issues due to this legacy. As a result of this:

- The fundamental design of critical infrastructure assets, e.g. switches and crossings (S&C) and track systems are not capable of meeting the demands of future rail transport, and have in general not been designed following a whole system approach.





- Rather than adopting risk and condition-based LEAN approaches to optimise Reliability, Availability, Maintainability, Safety (RAMS) and lifecycle costs; asset maintenance activities predominantly follow costly time-based regimes that often fail to define and target the root causes of degradation.
- The wealth of data and information on the status of assets and traffic have varying levels of quality and is distributed over a wide range of information systems and differing standards that restrict data access and exploitation.
- Power systems incur high and unnecessary energy losses: no closed-loop systems exist to balance energy demands.

### 3.2. Objectives of the IP and expected results

IP3 will enable a resilient, consistent, cost-efficient, high capacity and attractive European network by delivering operation critical research, development, and innovation for rail infrastructure. This will be achieved by the adoption of a whole system approach linking infrastructure and station design with maintenance actions, asset management and energy management:

#### **IP3 will target the overall Shift2Rail objectives:**

- enhancing the existing **CAPACITY** fulfilling user demand of the European rail system;
- increasing the **RELIABILITY** delivering better and consistent quality of service of the European rail system;
- reducing the **LIFE CYCLE COST (LCC)** increasing competitiveness of the European rail system and European rail supply industry

Specific technical impacts are listed for each Technical Demonstrator (TD) in the following sections.

IP3 will deliver outcomes which will produce a step change in the way that the European rail network is developed and operated, such that the infrastructure will improve the economic viability and attractiveness of the network. Some overall objectives to characterise this improvement are:

- Overall LCC and RAMS,
- Track performance and traffic disturbance, and
- Environmental performance.

Corresponding societal benefits include:

- Capacity,
- Operational reliability, and
- Competitiveness – share of transports.



These objectives are all geared to achieve the overall objectives outlined in the Strategic Master Plan:

- Improved reliability,
- Enhanced capacity,
- Improved customer experience,
- Lower investment costs,
- Reduced operating costs,
- Respect and adaption of TSIs,
- Removal of open-points, and
- Improved standardisation.

More specific objectives are listed under the respective TDs.

To obtain the goals there are a number of challenges which are discussed under each TD. In short, some major overall challenges are:

- to ensure a rapid implementation process – this is targeted by the inclusions of all affected parties in IP3,
- to ensure the identification of high-importance issues and the generation of relevant solutions – this work is already starting in the In2Rail lighthouse project, and
- to ensure a working cooperation between partners – also this is partly addressed by having many of the partners involved in In2Rail.

### 3.3. Past and ongoing European & national research projects

IP3 will build on the outcome of a large number of previous EU projects where applicable, including:

Acronym (EC Reference)	Description of Project
<b>IN2RAIL</b> (GA 635900)	IN2RAIL is to set the foundations for a resilient, consistent, cost-efficient, high capacity European network by delivering important building blocks that unlock the innovation potential that exists in Shift2Rail
<b>AUTOMAIN</b> (GA 265722)	Research results on mechanised track maintenance and inspection (tamping and grinding); LEAN analysis of working methods and processes to reduce possession times; demonstration of advanced switch monitoring; decision support tools for maintenance planning and scheduling
<b>CAPACITY4RAIL</b> (GA 605650)	Research work on infrastructure, train dispatching and timetable planning and monitoring. Recommendations for Open-Source and Open-Interface for advanced railway monitoring applications
<b>D-RAIL</b> (GA 285162)	Cost efficient measures to reduce derailments
<b>INNOTRACK</b> (GA 31415)	Analysis of major track cost drivers to reduce maintenance costs for sub-structure, track, S&C including LCC and logistics aspects
<b>INTEGRAIL</b> (GA 12526)	Proposed approaches and demonstrators for intelligent communication infrastructure, including information system architecture and semantic data structure
<b>INTERAIL</b> (GA 234040)	Integrated high speed inspection system based on a modular design
<b>MAINLINE</b> (GA 285121)	Life cycle assessment tool and findings regarding modern technologies for track, tunnels and bridges
<b>SMARTRAIL</b> (GA 285683)	Complimentary to MAINLINE with a life cycle assessment tool for other structures.
<b>MERLIN</b> (GA 314125)	Optimisation concepts and proposals for minimising energy demand
<b>PM'n'IDEA</b> (GA 234299)	Predictive maintenance methods for Metro and Light Rail Transport systems
<b>SAFTInspect</b> (GA 314949)	The SAFTInspect project aims to enable efficient in-service sub-surface inspection of manganese rail crossings by applying an ultrasonic inspection technique called Synthetic Aperture Focusing Technique (SAFT).
<b>smarTAIL</b> (GA 684856)	Enhanced implementation of smart coatings for railway wheels together with an effective smart coatings deposition technology.
<b>SUSTRAIL</b> (GA 265740)	Optimised track and substrate design and component selection to increase sustainable freight traffic as part of mixed traffic operations

### 3.4. Structure and set-up of IP3

#### 3.4.1. Structure

The IP3 is organised around eleven Technical Demonstrators (TD), which are briefly presented below and described in detail in later subsections. Figure 57 provides an overview of the interrelations between all of the TDs of IP3 and also shows how the TDs will be clustered together into Integrated Technology Demonstrators (ITDs).

**Figure 57: TDs and ITDs in IP3**

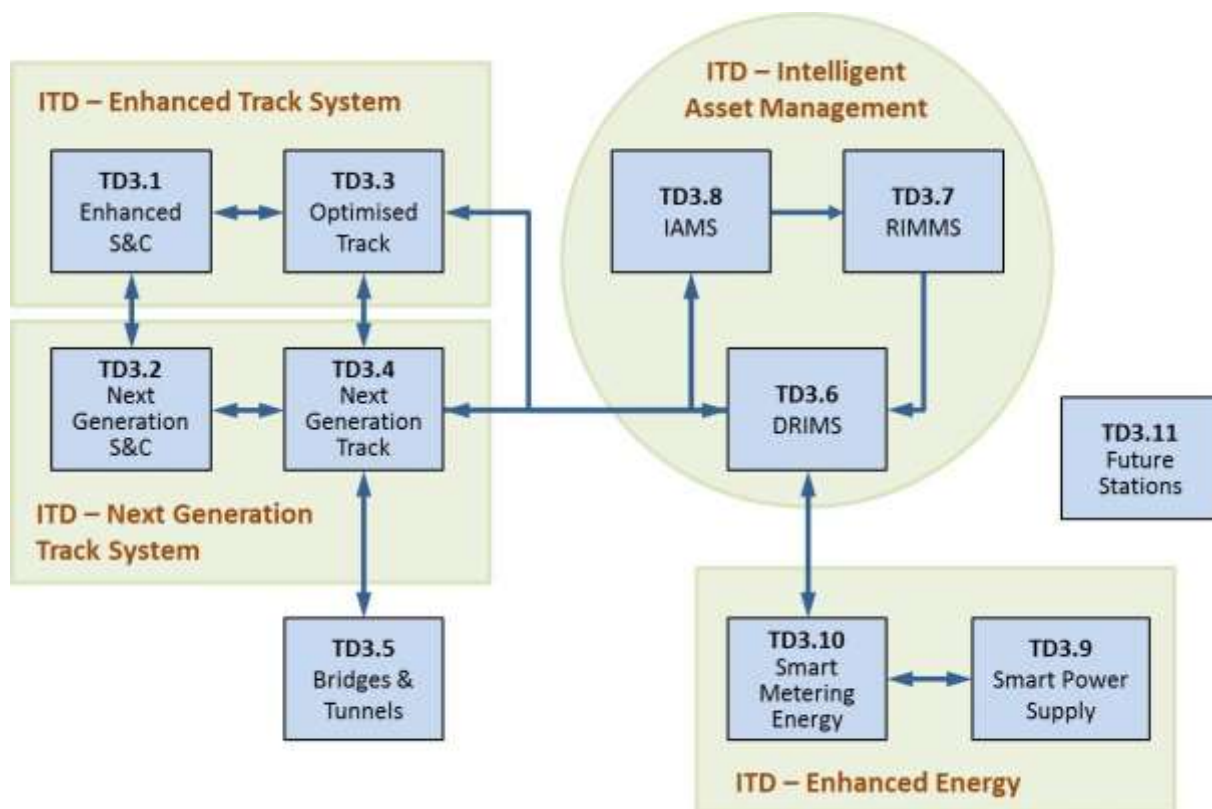

#### **TD3.1 Enhanced Switch & Crossing System Demonstrator**

The main objective of this TD is to improve the operational performance of existing S&C designs through the delivery of new S&C sub-systems with enhanced RAMS, LCC, sensing and monitoring capabilities, self-adjustment, noise and vibration performance, interoperability and modularity. The TD is organised into tasks with gradually more detailed analysis and design decisions.

#### **TD3.2 Next Generation Switch & Crossing System Demonstrator**

The TD aims to provide radical new system solutions that deliver new methods for directing trains to change tracks with the aim of increasing capacity, while reducing maintenance needs, traffic disturbances and life cycle costs. The TD is organised into a mixture of tasks with gradually more detailed analysis and design decisions and tasks related to specific technical challenges.



### **TD3.3 Optimised Track System**

The TD challenges track construction assumptions, currently implicit in track design, and explores how innovative solutions in the form of products, processes and procedures can provide higher levels of reliability, sustainability, capacity and LCC savings. The aim is to derive medium-term solutions, which require that the solutions need to be harmonized with current solutions and regulations. The TD is organised around a gradual refinement in design/evaluation of solutions.

### **TD3.4 Next Generation Track System**

The TD aims at drastically improving the track system targeting a time horizon some 40 years beyond present state-of-the art. This implies that step changes in performance are highly prioritized. The TD process follows a tightly integrated chain setting out from initial identification of long-term needs of the railway and potential solutions to meet these. The TD is organised around a gradual refinement in design/evaluation of solutions.

### **TD3.5 Proactive Bridge and Tunnel Assessment, Repair and Upgrade Demonstrator**

The main objective of the TD is to improve inspection methods and repair techniques to reduce costs, improve quality and extend their service life if possible. Also the reduction of noise and vibrations are prioritised objectives. The TD is organized around the different technical challenges to reach this end.

### **TD3.6: Dynamic Railway Information Management System (DRIMS) Demonstrator**

The TD defines an innovative system for the management, processing and analysis of railway data obtained from TD3.7. The focus is to provide high-quality input to the intelligent asset management actions within TD3.8. The TD is organised around the different steps required for developing such an analysis framework.

### **TD3.7: Railway Integrated Measuring and Monitoring System (RIMMS) Demonstrator**

The TD is to provide innovative tools and techniques for capturing information on the current status of assets in a non-intrusive and fully integrated manner. To this end, the TD focuses on asset status data collection in close interaction with TD3.1–TD3.5. The TD is organised around the different technical systems of the railway.

### **TD3.8: Intelligent Asset Management Strategies (IAMS)**

The vision is a holistic, whole-system approach of asset management employing collected and processed data provided by TD3.6 and TD3.7. This includes putting long-term strategies in the context of day-to-day execution of the maintenance and other maintenance activities.

### **TD3.9: Smart Power Supply Demonstrator**

The global objective of a railway smart grid is to develop a railway power grid in an overall interconnected and communicating system. The TD is organised with successively refined design to obtain this target.

### **TD3.10: Smart Metering for Railway Distributed Energy Resource Management System Demonstrator**

The objective of the smart metering demonstrator is to achieve a fine mapping of energy flows within the entire railway system, as a basis of any energy management strategy. To this end, the TD is organised with successively refined analyses and developments.

### **TD3.11: Future Stations Demonstrator**

The primary objective is improved customer experience at stations. The TD is organised around four identified key functional demands; two demands relate to improving capacity and security in large stations, one demand relates to the design of small stations with the objective of reducing whole life costs and standardising design where possible and the final demand relates to accessibility.

#### **3.4.2. Links to other IPs**

There are also interfaces between IP3 and other IPs: Track and switches and crossings interact with the operating vehicles (IP1 and IP5). In addition there is also an interface to the power supply and metering from IP1 and IP5. Stations have a strong interaction with passenger services (IP1) and with IT solutions (IP4). Maintenance TDs will be influenced by the operating vehicles (IP1 and IP5) and will also affect traffic management (IP2). Finally, requirements on tunnels and bridges relate to operating traffic (IP1 and IP5). These interactions are graphically presented below.

This motivates a high priority of IP3, and also imposes demands on IP3 to interact closely with other IPs. In addition IP3 relates to basically all crosscutting activities.

**Figure 58: Relationship of IP3 with other IPs and CCA**

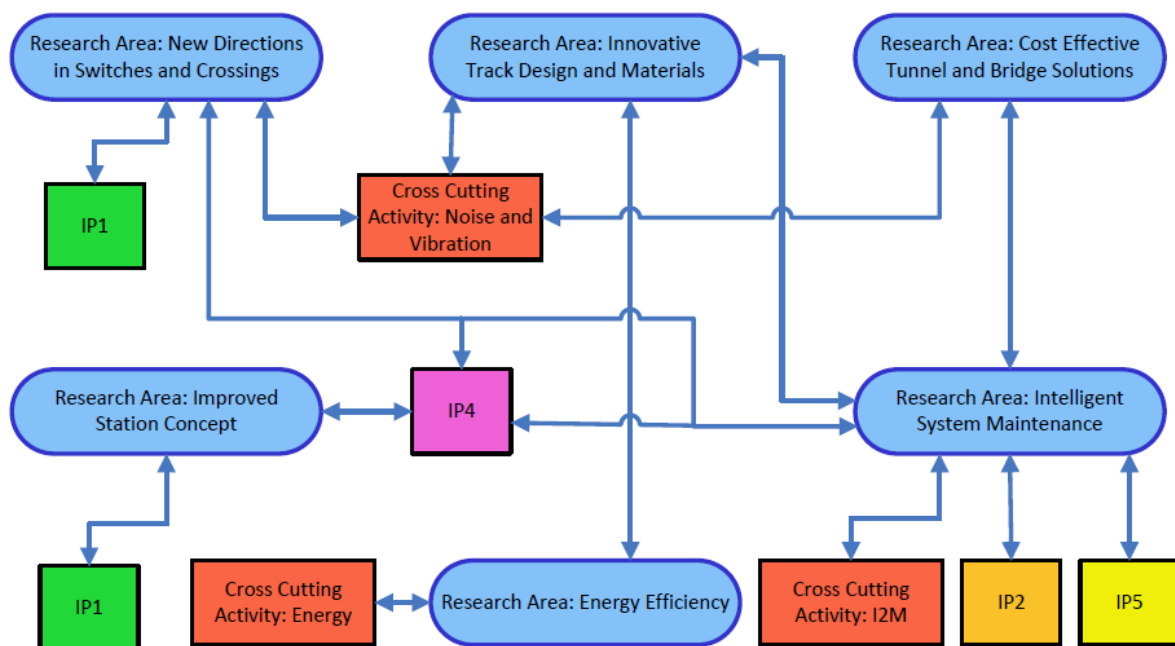



### 3.4.3. Approach in IP3

#### **Whole Life Value and Cost appraisal**

Innovations in the Infrastructure IP are aimed at optimising the balance between performance, cost and risk over the lifecycle of the asset. It is necessary therefore to have an appraisal method that can determine these parameters on a consistent and comparable basis for all the innovations under consideration. The most promising solutions from the prototypes that will be taken forward to full scale tests will be selected using this appraisal method. Figure 59 provides the modelling framework proposed for undertaking a whole life cost and value appraisal.

The objective of the framework is to enable a range of options to be analysed at any point in the asset lifecycle and to determine the impact of each option on performance, cost and risk. The framework has five main components, each of which is summarised below.

#### **Controllable Decisions**

These are the options that need to be considered at each stage of the asset lifecycle. For example, radically different options will be considered in the concept and design phase. It will also be necessary to consider the maintenance strategy and the timing of renewal and whether operational limitations may be required. The appraisal method should allow options to be analysed individually or in combination.

#### **Constraints**

The whole life appraisal will recognise potential constraints. These include limitations on possessions for highly utilised routes, potential for limited access to the assets for working to inspect and repair faults, and may also include limitations in the supply chain or the availability of funding that could impact the delivery in a non-optimal way. Such constraints may limit the rollout of new technologies and therefore the timescales over which the benefits are realised.

**Figure 59: Appraisal framework for Whole Life Value and Cost analysis**

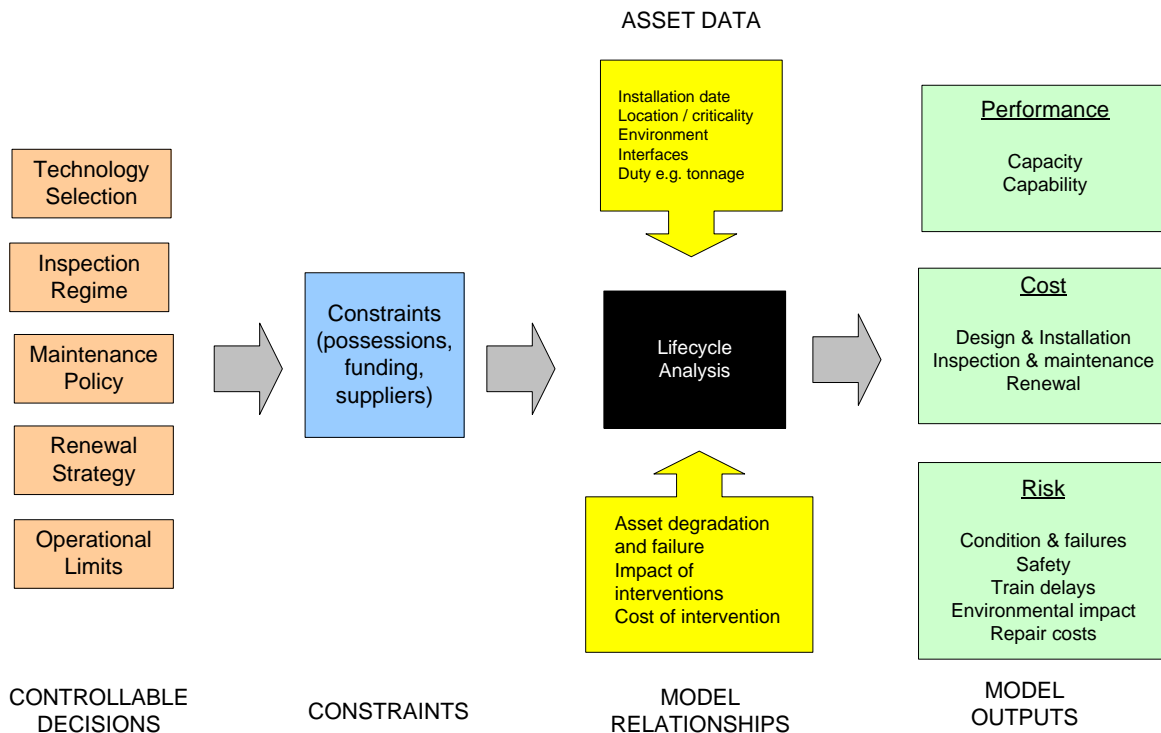

### **Model relationships**

These are the key relationships that support the calculation of performance, cost and risk at each stage of the lifecycle from the whole system point of view. These include, for example, the vehicle dynamics together with simulation models representing asset degradation and failure (including interactions between assets), the impact of intervention activities and the modelling of variable costs e.g. possessions.

### **Asset data**

The model relationships require a range of data inputs. This includes direct information on the asset, such as the installation timing, operating environment, system interfaces and locations. All of these parameters will be modelled for a range of railways that can be found within EU. The datasets also include other user-defined parameters such as discount rates and the time horizon for the calculation.

### **Outputs**

The outputs will support a continuous evaluation of the performance, cost and risk of an option or combination of options.



**Programme timescales**

The following chart shows the proposed time scales for each of the TDs in the programme.

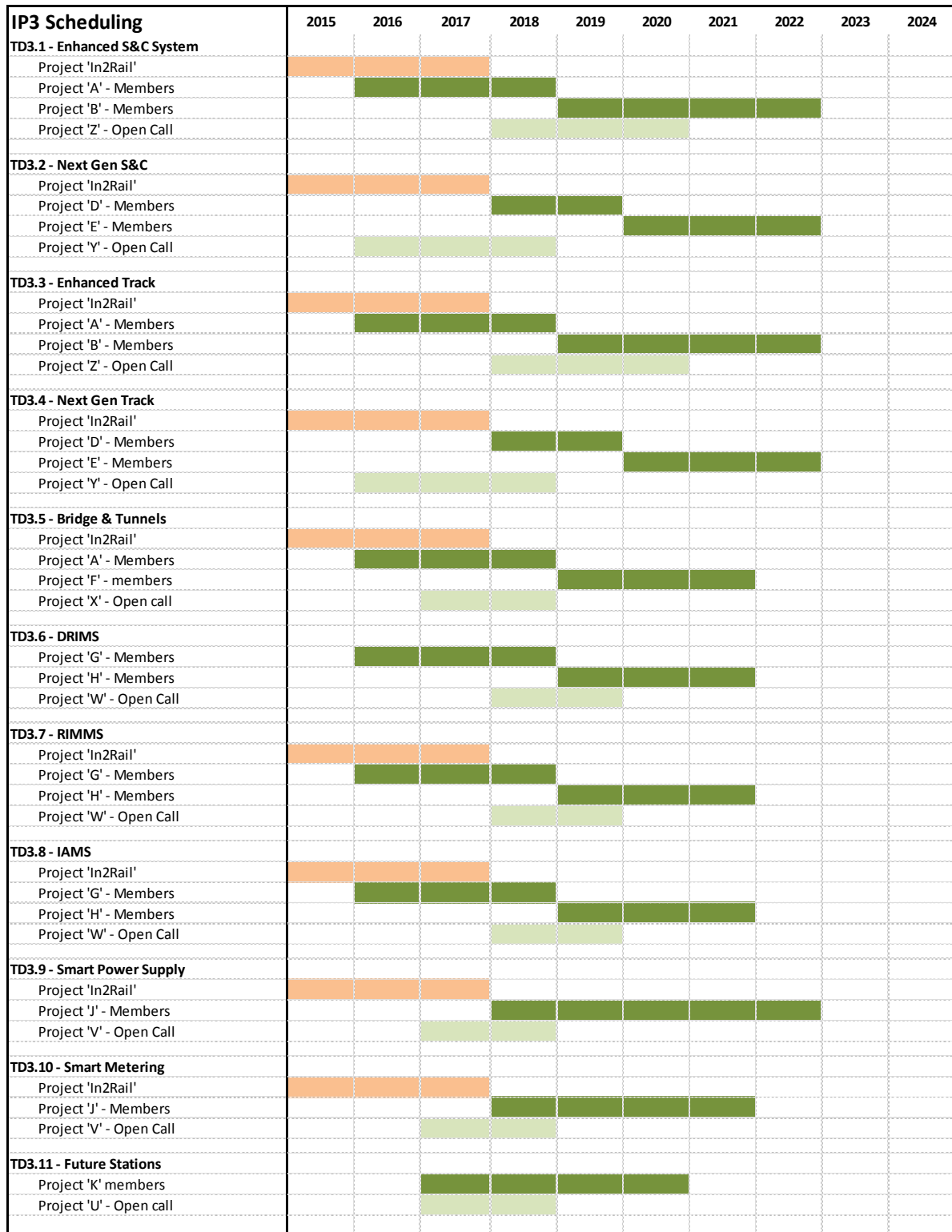



### 3.5. The Technology Demonstrators of the Cost Efficient and Reliable Trains Innovation Programme

#### 3.5.1. TD3.1 Enhanced Switch & Crossing System Demonstrator

##### *3.5.1.1. Concept and objectives of the Enhanced Switch & Crossing System Demonstrator*

###### Context

Switches and crossings (S&C) are a critical sub-system of the railway infrastructure, in terms of safety and performance. Service affecting failures associated with S&C account for some 25-30% of all infrastructure failures on European railways. Furthermore, a significant proportion of the life cycle cost (LCC) of S&C also relates to monitoring and maintenance activities required to ensure that the system is functional for the safe running of trains. With the target of Shift2Rail to increase the operational capacity of railway networks, it is important that these activities and critical S&C failure modes are significantly reduced.

The area with the greatest potential for innovation and development for TD3.1 is to address the deficiencies of the point operating system by designing out all known failure modes from all associated sub-systems that constitute switch actuation, locking and detection whilst also considering the wheel-rail interface and rail support conditions. This can be achieved by adopting a systems engineering approach for developing new technical solutions for components and by integrating remote condition monitoring with a feedback loop for self-diagnosis and adjustment. The system has to be robust, reliable, immune to extreme weather and have low life cycle cost (LCC). The design will also consider the green aspects, such as resource utilisation and how carbon neutrality can be improved. Emphasis will be placed on sustainability and environmental issues with the objective of ensuring that a holistic strategy to minimize environmental footprint and whole life energy consumption.

The innovative approach is to adopt the growing trend of blending mechanical, electro-mechanics, digital control systems and electronic design elements into one integrated S&C system. By focusing on the development of a truly cross-functional integrated system that uses modern technology in innovative ways for the S&C operating system, it opens new opportunities for infrastructure maintainers to provide in-time preventative maintenance that will increase system longevity and availability and therefore service revenue and reduce manual intervention. Designing for maintainability and manufacturability will also be included as key considerations throughout the duration of TD 3.1. New designs will also consider interoperability and inter-changeability needs of the European railway systems.

This TD will interact with:

- IP2 – TD2.11 Smart Radio-Connected all-in-all Wayside Objects
- IP3 – TD3.2 Next Generation Switch & Crossing Systems
- IP3 – TD3.3 Optimised Track Systems
- IP3 – TD3.4 Next Generation Track Systems

- IP3 – TD3.6, TD3.7, TD3.8 Intelligence Maintenance Demonstrators

### **Definition and justification of the objective**

The main objective of TD3.1 is to improve the operational performance of existing S&C designs. This will be achieved through the delivery of new S&C sub-systems with enhanced RAMS, LCC, sensing and monitoring capabilities, self-adjustment, noise and vibration performance, interoperability and modularity.

The key objectives, results and related deliverables of this TD are summarised in the following table:

Objectives	Results	Deliverable
Increased availability through reduced complexity.	Reduction of failure modes leading to improved reliability and availability.	Specification, development and demonstration of S&C based on technology transfer.
Increased availability and reduced LCC through improved asset management.	Improved sensor system for real time asset information to enable condition based predictive maintenance.	Specification, development and demonstration of the intelligent assets and maintenance.
Increased availability and lower LCC through improved maintenance.	Reduction in corrective and preventative maintenance including inspections in favour of predictive maintenance and self-adjustment.	Specification, development and demonstration of more reliable technologies and interfaces, and assets that allow for less intrusive maintenance.
Improved competitiveness and public acceptance through improved green credentials, less noise and vibrations and improved sustainability.	Improved peak noise and vibration behaviour when vehicles transition through an S&C unit. With less resources and energy used for maintenance.	Changes to switch blade, crossing geometry, track components and materials together with self-adjustment and tribological design rules keeping the S&C system in optimal working condition alleviating the need for intensive maintenance.
Cost reduction.	New architectures, technologies and tools to reduce cost during engineering, integration and commissioning phases.	Specification, development and demonstration of the enhanced S&C system, with fewer and more reliable components, more flexibility and modularity and easier integration and commissioning procedures.

**NB:** A full Life Cycle Cost Analysis (LCCA) will be completed to evaluate long-term investment options emanating from TD3.1. The LCCA will include costs from every stage of the product life-cycle, including initial capital expenditure, maintenance, operations, renewals and decommissioning.

### **Alignment with Shift2Rail Strategic Master Plan**

The specific benefits of TD3.1 have a major impact in the Shift<sup>2</sup>Rail system-level KPIs:

- Enhanced sensors within S&C for improved reliability and LCC.

- Improved movement system for improved reliability and LCC.
- Optimised switch and crossing design and predictive maintenance for improved reliability and LCC.
- Embedded sensors integrated into S&C for increased reliability and LCC.
- Enhanced S&C integrated with track improvements for increased reliability and LCC.
- New S&C reduced transient noise generated by S&C relative to track by -3dB.
- Solutions are validated and tested to extremes of operating ranges.
- Generates solutions for low cost M&R, 24/7 working.
- Improved safety of track workers.
- Increased interoperability of products and processes

### ***3.5.1.2. Technical ambition of the Enhanced Switch & Crossing System Demonstrator***

#### **Ambition**

Following the technological revolution in the 19th century, developments within the rail industry were largely organic in nature with gradual improvements in track and S&C designs. In fact, the overall design of the point operating system has fundamentally been unchanged for the last 30 years. To accommodate gradual increases in line speed, volume of traffic and axle loads, the S&C system has incrementally evolved but from a sub-system level. The ambition of TD3.1 is therefore to consider a whole-system approach to enhancing common generic S&C designs and to incorporate modern mechatronics for improved system kinematics and control. The technologies to be developed within the enhanced S&C pillar include:

- Enhanced Sensors and Inspection Processes,
- New Moving Parts and Materials,
- Embedded and Integrated Sensors,
- Enhanced Track Sub-Structure for S&C, and
- Self-Adjusting Switches.

These will be achieved by assessing three major topics:

#### *Enhanced S&C Whole System Modelling, Simulation and Design*

Integrated modelling, simulation and design methods will be used from the start to integrate the mechanical, electrical and software components into the design to deliver the required improved capabilities. The use of Computer Aided Engineering (CAE) methods together with integrated testing of materials, components and subsystems, for the entire S&C system, enables iterative optimisation of the design. This then leads to a complete virtual prototyping of the planned design that contains



all related linked data. The models can be updated as the design develops and fine-tuned up to the final testing phase, allowing the detection and elimination of any system problems early in the design process and any associated construction problems further down the line. The models can also be used to generate production information for scheduling, planning and refinement, further improving efficiency and reducing errors. Knowledge of the whole S&C system, sub-system and component lifecycles and rates of degradation will be established and fed to TD3.8 to inform intelligent maintenance decision support tools.

#### *Enhanced Design, Materials & Components*

The focus will be to further develop existing S&C systems by improving encapsulated designs such that they can be pre-assembled and 'plug and play' onto new layouts or retrofits. The ability to use components from different manufacturers within the same design will also be included. Redesigning the moving elements of the S&C will also affect track circuit failure modes. This demonstrator therefore provides an opportunity to improve not only switch actuation but also lock and detection mechanisms such that there are reduced electrical problems and improved physical protection to components required for track circuit functionality. Enhanced S&C welding processes and technologies will also be considered with regards to both construction and repair.

#### *Enhanced Control, Monitoring & Sensor Systems*

Existing S&C systems utilise independent sensor systems and do not incorporate feedback loops in most functions. The use of electronics and software features and products are common place in other industries. Advanced S&C control can provide functional status to a maintainer for fault finding and a minimal trigger type control for the S&C unit itself. The enhanced S&C technology demonstrator will develop reliable and robust switch actuation, locking and detection system designs that will be intelligently controlled with self-adjustment capabilities. S&C deterioration data, obtained through embedded and integrated sensors, will also be fed into TD3.6 to inform an innovative asset management system.

TD3.1 will bring innovation to the subject developing a truly cross-functional integrated system that uses modern technology in innovative ways for the S&C operating system. The design will also consider environmental impacts, such as noise and vibration, low energy consumption and sustainability. While the work proposed is novel and complementary, it is vital that TD3.1 builds on the knowledge gained from previous research projects and works in parallel with ongoing projects to ensure maximised benefit and minimal duplication. TD3.1 will also assess how any proposed, novel technologies can be transferred into the rail industry.

#### **Key areas of focus:**

- Identification of S&C failure modes, root causes and cost drivers;
- Development of enhanced S&C whole system behaviour models for better system understanding and design optimisation. Computer Aided Engineering (CAE) will be extensively utilised from the start to integrate mechanical, electrical and software components into the design to deliver the required improved capabilities;



- Development of improved components and technologies to optimise the points operating system (actuation, locking and detection) for RAMS whilst also reducing whole system LCC;
- Development of new sustainable materials to minimise deterioration and failures allowing for extended asset life, reduced maintenance intervention and lower LCC;
- Enhanced wheel-rail interaction through improved S&C contact geometries;
- Enhanced inspection, monitoring and measurement systems through use of embedded and integrated sensors for self-diagnosis and remote condition monitoring to quantify asset condition, deterioration rates and performance as a whole. The data would need to be fed into the intelligent maintenance work stream to enable accurate trend analysis for predictive maintenance;
- Use of mechatronics and the improved sensor system to create a feedback loop to facilitate self-adjustments and switch control to maintain safety limits and provide continuous availability, such as achieving automated lock and detection assurance; and
- Welding technologies for S&C system construction and repair.

### **Market Uptake**

By the end of the proposed work, all the principal elements required for rapid market uptake will have been achieved. These include:

- Demonstration of technologies in a real operation environment that provide objective measures and hence give credibility and clearly show benefits;
- Products and systems that are developed for easy and high quality manufacturing;
- Solutions designed to be simple to operate, easy to maintain, completely interoperable and full inter-compatibility, allowing for effective and efficient competition between suppliers;
- Shift2Rail will provide products and systems that have been independently assessed for compliance with European standards and requirements giving confidence to Infrastructure Managers and permitting rapid deployment due to the development of processes, guidelines and procedures for hybrid assessment (virtual + experimental) and cross acceptance and rapid deployment for new materials, components and systems;
- Shift2Rail will be able to provide evidence for successful system integration of the products greatly helping Infrastructure Managers to gain trust in the innovations and products;
- With the infrastructure managers as part of Shift2Rail, the products will come with a pedigree of end users needs having been properly addressed;
- Reliable and accurate Life-Cycle Cost information provided with the products will help with technology introduction and the case for rapid deployment into the railway system; and

- The Shift2Rail development will stimulate new product introduction, allow for the supply chain to manage the risk better and allow longer warranties to be issues in line with the construction industry thereby greatly helping product acceptance and deployment.

### **Technical Ambition of TD3.1**

State-of-the-art	Advance Beyond State-of-the-art (Shift2Rail)
<p><b>Design</b></p> <p>The current S&amp;C systems have been designed by considering existing materials, computers, electronics and mechanics in mind but not from a whole system perspective. As a result, the existing state-of-the-art solutions have, in many ways, not been optimised with regards to Reliability, Availability, Maintainability and Safety (RAMS).</p>	<p><b>Design</b></p> <p>An integrated whole system approach will be used to achieve multi-disciplinary optimisation. The new design will result in new architectures, technologies and tools to reduce cost during engineering, integration and commissioning phases. With fewer and more reliable components, more elasticity and flexibility, inter-changeability and modularity, and easier integration and commissioning procedures.</p>
<p><b>Assessment</b></p> <p>Individual time-consuming assessment processes for new S&amp;C systems for individual railway operators.</p>	<p><b>Assessment</b></p> <p>Guidelines and procedures for hybrid assessment (virtual + experimental) and cross acceptance for new materials, components and systems.</p>
<p><b>Installation</b></p> <p>Installation of S&amp;C requires many steps and manual actions to locate the unit in its new home. In a similar way replacement of an S&amp;C unit or many of its parts require procedures that have their origins in the original 150 year old design.</p>	<p><b>Installation</b></p> <p>The proposed switch design will attempt to make the unit and all parts more geared towards automated installation and maintenance and in-situ service. Adaptation to heavy plant and high output installation and maintenance will approach the problem with today's automation.</p>
<p><b>Operational</b></p> <p>Existing points operating equipment (POE) do not have the necessary level of redundancy to ensure that the switch remains operational under right side failure conditions. For example, a switch may be adequately locked but, due to detection failure, is placed out of service.</p>	<p><b>Operational</b></p> <p>The enhanced switch design will include multiple levels of system redundancy to ensure that right side failures do not affect railway operations. This will be combined with a sensor system to inform engineers that the right side failure has occurred to enable reactive maintenance planning.</p>
<p><b>Inspection and Maintenance</b></p> <p>Current design is labour intensive and requires maintenance staff to tend to the assets at regular intervals to survey the state of the asset as well as to make adjustments and refill consumables.</p>	<p><b>Inspection and Maintenance</b></p> <p>The new design will utilise enhanced S&amp;C component designs and remote sensors to permit a reduction in the need to visit the unit for condition surveys. Adjustments will as far as possible be automatic.</p>

### **Technical Limitations/Barriers**

The barriers to innovation in Shift2Rail include many themes and may be [P]olitical, [Ec]onomic, [S]ocietal, [T]echnological, [L]egislative, [En]vironmental in their nature. The bullet points below identify the barriers and obstacles which may limit the impact of TD 3.1 and reduce market uptake:

- Lack of investment in less profitable lines reduces uptake of innovative solutions [P];
- Restricted investment capital is a barrier to selecting optimised LCC option [Ec];



- Existing long term contracts and framework agreements restrict rapid uptake of new technology **[Ec]**;
- Resistance to change due to culture and competence through ‘patterning’ (forming of fixed ways of behaving) **[S]**;
- Current decision making sometimes based on subjectivity rather than actual data analysis **[S]**;
- Current ways of working not consistent across Europe, increases difficulty in making a universal incremental change or step-change **[S]**;
- Legacy systems in most of the EU countries and lack of harmonisation are an obstacle for interoperability **[T]**;
- European disparity in technological level **[T]**;
- Regulatory/legal barriers around introducing new products and techniques – i.e. national notified rules; national product acceptance processes; national standards; and specifications **[L]**; and
- Climatic variation across Europe affecting compatibility, interoperability, and standardisation **[En]**.



### References to existing EU funded research projects

Potential synergies can be found with the following FP6, FP7 and H2020 EU-funded research projects:

Acronym (EC Reference)	Description of Project
<b>IN2RAIL</b> (GA 635900)	IN2RAIL is to set the foundations for a resilient, consistent, cost-efficient, high capacity European network by delivering important building blocks that unlock the innovation potential that exists in Shift2Rail
<b>AUTOMAIN</b> (GA 265722)	Research results on mechanised track maintenance and inspection (tamping and grinding); LEAN analysis of working methods and processes to reduce possession times; demonstration of advanced switch monitoring; decision support tool for maintenance planning and scheduling
<b>CAPACITY4RAIL</b> (GA 605650)	Research work on infrastructure, train dispatching and timetable planning and monitoring. Recommendations for Open-Source and Open-Interface for advanced railway monitoring applications
<b>D-RAIL</b> (GA 285162)	Cost efficient measures to reduce derailments (setting limit tolerances).
<b>INNOTRACK</b> (GA 31415)	Analysis of major track cost drivers to reduce maintenance costs for sub-structure, track, S&C including LCC and logistics aspects
<b>INTERAIL</b> (GA 234040)	Integrated high speed inspection system based on a modular design
<b>MAINLINE</b> (GA 285121)	Life cycle assessment tool and findings regarding modern technologies for track, tunnels and bridges
<b>SAFTInspect</b> (GA 314949)	The SAFTInspect project aims to enable efficient in-service sub-surface inspection of manganese rail crossings by applying an ultrasonic inspection technique called Synthetic Aperture Focusing Technique (SAFT).
<b>SUSTRAIL</b> (GA 265740)	Optimised track and substrate design and component selection to increase sustainable freight traffic as part of mixed traffic operations

#### **3.5.1.3. Specific Demonstration activities and contribution to ITDs/SPDs**

##### **Vision:**

The vision for the enhanced switch and crossing system demonstrator is to seek, by performing trials, the validation of new S&C components within current S&C designs. This will have the double benefit of bringing forward incremental improvements to the existing S&C system performance. In addition, each part of the new design will be validated such that it can be adapted for use within the radical redesign of S&C (TD 3.2), thereby reducing the risk.

Figure 60: Relationship of TD3.1 with other TDs

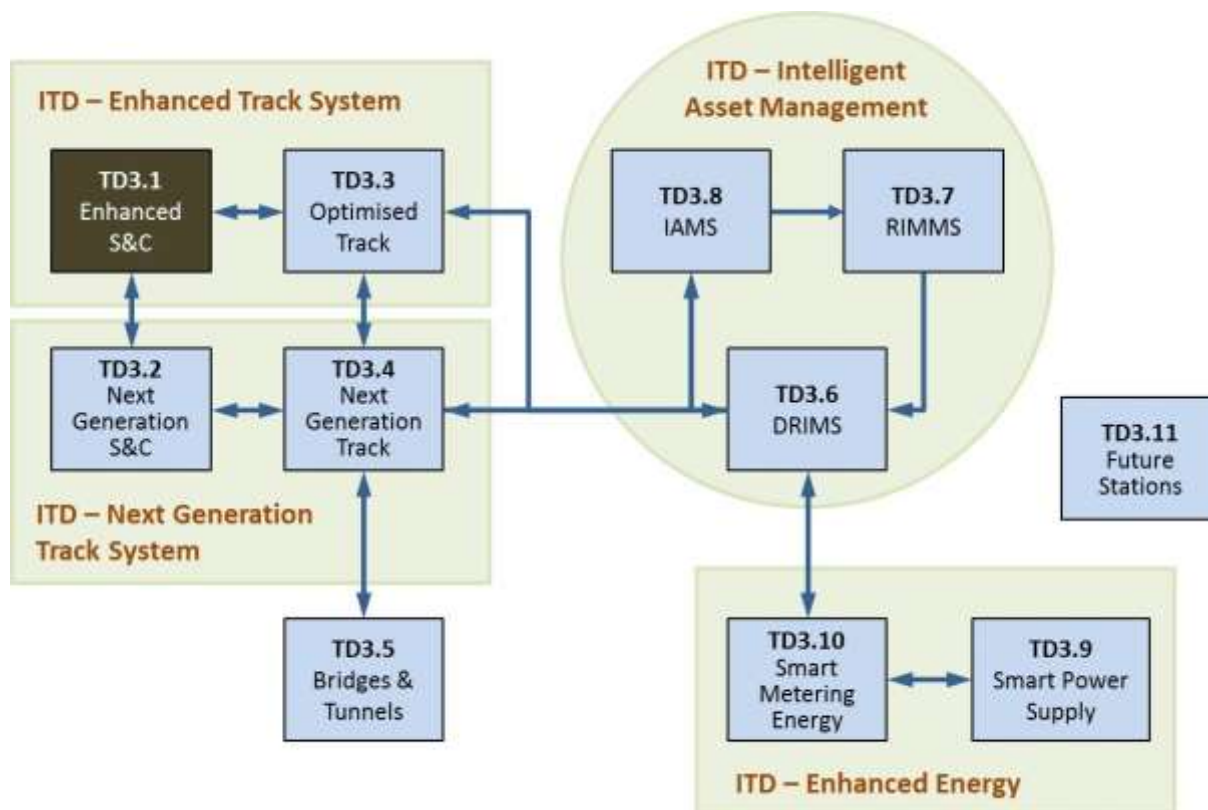
**Approach:**

Technology demonstration of the enhanced switch and crossing system will be presented and will take a two staged approach:

**1. Virtual Demonstrator (TRL5)**

To demonstrate the interaction with signalling systems and safety performance with regards to interlocking, a virtual demonstrator will be used. Simulations will include both structural integrity and software/control system integrity to demonstrate improvements in overall S&C system reliability.

**2. Full Scale Demonstrator (TRL7)**

A full-scale demonstrator will be hosted in an operational environment under realistic dynamic loading conditions. Additional system monitoring, above and beyond the designed system RCM, will be commissioned to provide system performance data for comparison against existing EU S&C systems. This testing must be done on an infrastructure test facility capable of simulating realistic worst case annual traffic and points operations.

The full-scale demonstrator is envisaged to be combined with TD3.3 to form an Integrated Technology Demonstrator (ITD). It is anticipated that the ITD will be held at the test track in Sweden, which was previously used during the recent EU funded project INNTRACK.



#### ***3.5.1.4. Impact of the Enhanced Switch & Crossing System Systems Demonstrator***











##### **Benefits**

The following benefits are envisaged through implementing Shift2Rail TD3.1:

- Alignment of Infrastructure Managers system and design resources and targets with suppliers will 'quadruple' both the effort and funding to generate the solutions.
- Solutions developed in the demonstrators will be validated and tested to extremes (100 Million Gross Tonnes), which is something that the industry and Infrastructure Managers normally cannot do.
- The EU industry will also benefit from the results of TD3.1 activities, as it will create technological leadership supported by a combination of innovation and the revision of technical standards, setting an effective advantage for the European rail industry.
- End users will also realise an increase of the operational reliability (less service disruptions) as a result of more robust systems based on less physical components, enhanced assessment, increased reliability and LCC reduction.

### Technical impact

The following technical impacts are envisaged by the implementation of TD3.1 and have been developed in the context of the three specific Shift2Rail global targets:

Impact type	Shift2Rail Impact	Contribution to KPIs (large spot=high contrib.)
<b>100% Capacity Increase</b>	Improved RAMS performance (Reliability, Availability, Maintainability and Safety) of S&C through enhanced S&C sub-system and component design.	
	Intelligent asset monitoring and sensing technologies reducing the frequency of manual inspection and maintenance activities.	
	Greater capacity to run more trains on quiet infrastructure in some locations (100% more trains if 3dB reduction is achieved).	
	Increased network availability through enhanced, predictive maintenance capabilities reducing disturbance of operations.	
	Reduction in critical, service affecting failures by introducing redundancy within critical S&C sub-systems.	
	Simplified, faster S&C installation through modular approach.	
<b>30% Reduction in LCC</b>	Extended asset operational life through enhanced, whole system S&C design and materials selection.	
	Embedded and integrated sensors for self-diagnosis and adjustment will enable S&C to retain optimum setup without the reliance on manual interventions.	
	Generates low cost solutions for maintenance and renewals whilst considering 24/7 working and increased safety for track workers	
	Whole system design for interoperability and inter-changeability promoting healthy competition within the supply chain.	
<b>50% Increase in Reliability &amp; Punctuality</b>	Improved S&C reliability through continuous monitoring of system degradation enabling timely and focussed maintenance interventions (predictive maintenance).	

### Contribution to TSI/Standards

TD3.1 is expected to propose changes to existing TSIs or the generation of new TSI requirements and will actively target the closure of relevant open points. The improvements and knowledge gained is expected to influence best practice in S&C implementation, operation and maintenance. National and International Standards relating to the areas of S&C, Track, Ballast, installation, inspection and maintenance might be affected, however. Industry Standards and Company Standards will not be targeted.















### **Strategic impact**

A summary of the strategic impacts produced by the implementation of the TD results and discoveries is given below. This is organised along three main aspects:

1. the support to the competitiveness of the EU industry;
2. the compliance with the EU strategic objectives; and
3. the degree of maturity of the solutions envisaged to be realised and put into practice in the railway sector. This is expected to provide an overview of the effects generated at larger scale by the application of the TD results.

**Strategic Impacts**

Impact type	Shift2Rail Impact	Contribution to KPIs (large spot=high contrib.)	
<b>Support the competitiveness of the EU industry</b>	<b>Global technological leadership</b> supported by a combination of innovation and technical standards, setting an effective advantage for the European industry:		
	Whole system modelling to reduce existing S&C failure modes through design		
	Integrated S&C RCM with automated self-correction and adjustment		
	Enhanced wheel to S&C interface conditions		
	Improved redundancy of safety critical systems for enhanced system reliability		
	<b>Increase attractiveness and competitiveness:</b>		
	Increase of operational reliability (less service disruptions) through more robust systems based on less physical components, enhanced assessment and debugging concepts, and more flexible processing of information.		
	Asset Lifecycle Cost (LCC) reduction through virtual assessment, lower physical complexity of systems and increased RAMS performance.		
	Support capacity increase because of reduced service affecting failures.		
	Automation of S&C inspection (via RCM) will remove the need for staff to be on the track (improving safety and maintenance efficiency) and will reduce the reliance on subjective views of asset condition.		
<b>Enhanced customer experience</b>			
Improved customer ride quality through improved wheel-rail interface conditions			
<b>Compliance with EU objectives</b>	<b>Promotion of modal shift:</b>		
	A big impact brought by the implementation of these new technologies towards avoiding service disruptions and adding new capabilities.		
	Improving S&C 'green' credentials through lowering LCC and increasing asset life, performance and availability through whole system design whilst considering manufacturability and maintainability. The carbon footprint of S&C can be reduced through better integration between sub-systems and automated self-diagnostics via RCM. Data trending will further reduce LCC through enabling predictive and preventative maintenance (opposed to reactive).		

Impact type	Shift2Rail Impact	Contribution to KPIs (large spot=high contrib.)
	Supporting fair and efficient supplier competition and enhanced interoperability through inter-changeable solutions fitting a common component or component assembling. This will also support achieving a Single European Rail Area (SERA).	
	Support to capacity increase by introducing additional levels of redundancy and hence reliability to existing S&C systems. In turn, this will reduce service affecting failures, enabling the existing network to run at an optimised capacity level.	
<b>Degree of maturity of the envisaged solutions</b>	Currently, most of the proposed technologies are at low Technology Readiness Levels (TRL) of between 1 and 2 ( <i>i.e.</i> principles observed and the possibility of using them formulated). At the end of Shift2Rail, it is expected that the successful concepts are brought to TRL 6 or 7 ( <i>i.e.</i> technology demonstrated in relevant environment and system prototypes demonstrated in operational environment).	

To obtain a complete understanding of the contributions to KPIs this table should be read in conjunction with the equivalent table within TD3.2 – Next Generation S&C Systems.

### ***3.5.1.5. Implementation of the work programme***

#### **Overall Approach and Methodology**

The proposed work stream will seek to develop a new concept of switch operating system, moving away from the predominantly mechanical system of moving switch blades. The proposed work plan is closely interlinked with TD3.2 – Next Generation Switches and Crossings. The TD3.1 work plan consists of five development stages:

#### *Enhanced Sensors and Inspection Processes*

Sensors for use in the harsh railway environment must be robust and resilient. Available sensors will be reviewed and redesigned incorporating modern advances in embedded sensors to enable automatic self-adjustment and condition measurement, and be fully readable by railway asset management systems. The data would feed into the intelligent maintenance system RIMMS (TD3.7) and enable 'predict and prevent' maintenance scheduling generated by the ISMES system developed in TD3.8. This information will use open interfaces and standards thus making it transferable across the industry and allow change management and future proofing of these otherwise highly complex systems.

To ensure robustness for all climatic conditions and especially reliable and safe operation in ice and snow, the range of operation of the sensors will be evaluated. The work stream will characterise the movement monitoring of the existing S&C to allow a proper interpretation of measurements in different environmental conditions. The results will be captured by the RIMMS sub system. The sensor system for the movement monitoring will be evaluated against existing motor current based systems.



### *New Moving Parts and Materials*

The proposed new switch actuation system and locking and detection philosophies will take applications from machinery science already in use in other sectors (*e.g.* Aerospace and automotive) and transfer these materials, technologies and techniques into the railway. An example is the use of modern actuators and motors in place of mechanical parts to further enhance existing encapsulated S&C designs, with less failure modes and easier diagnosis. As the project progresses, key output will be transferred to TD3.2 for the radical top down development of a new S&C in a typical 2 stage programme.

### *Embedded and Integrated Sensors*

Once suitable sensors and switch moving parts have been confirmed and rigorously tested, the design phase will move to embedding the sensors into the whole system to further fine-tune the physical design. The ease of assembly and removal in the form of 'plug and play' is essential so that a faulty sensor system can be quickly replaced to minimise on-track time.

### *Enhanced Track Sub-Structure for S&C*

The work stream in collaboration with the short and medium term Track demonstrator will consider, from first principles, the interaction between the S&C system and sub-structure. Specific features to consider include overall stiffness requirements of the S&C system and the dynamic movement of the rails in response to wheel passages. These will feed into the next stage for fine-tuning the self-adjustment facilities.

### *Self-Adjusting*

To accelerate this function, continuous test and verification of the embedded sensors at a system level will be carried out using dedicated simulation software and models. The self-adjusting feature will be rigorously tested to encompass all possible variations in operating conditions for setting safety limits. The work stream will be closely linked with the remote monitoring and an effective asset management regime, supported by the RIMMS, DRIMS and IAMS system developed in TD3.7, TD3.6 and TD3.8.

Results from this TD will feed into the development of TD3.2 for use in a new concept S&C design.



**Figure 61: TD3.1 and TD3.2 Two Stage Approach**

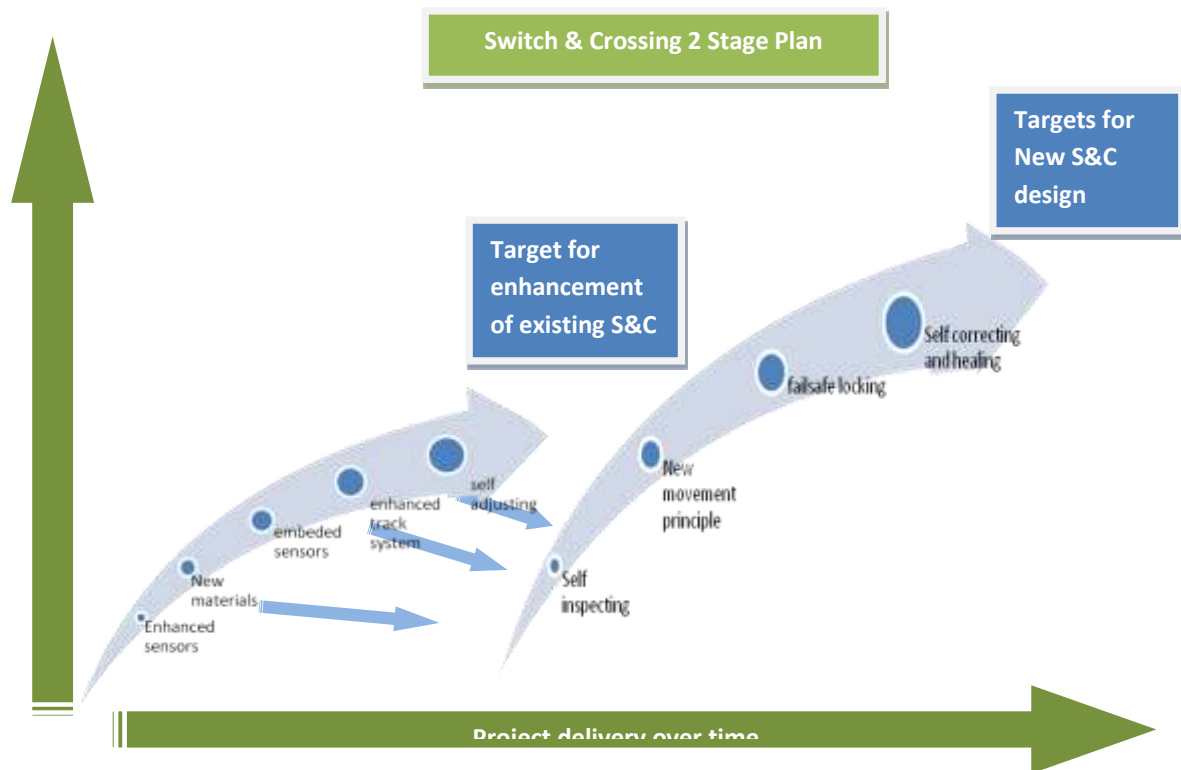

The vision of TD3.1 is to provide a compact and encapsulated point operating system that fits in new and existing layouts, regardless of the track configurations and is scalable across a range of speeds and geometries. The developed system would, by design, be low maintenance and high reliability and embrace the three pillars of sustainability hence ensuring that social, economic and environmental requirements are satisfied.

The new operating system and components down to Line Replaceable Unit (RLU) level will be analysed using up-to-date techniques and tools. It is anticipated that this will include Fault Tree Analysis (FTS), Failure Modes and Effects Analysis (FMEA) and possibly Markov analysis. Critical systems or sub-systems will be modelled using Reliability Block Diagram (RBD) and quantitatively assessed with the latest tools such as ISO graph availability workbench and procedure for RAM analysis in mechanical systems. Where long-term data is difficult to acquire, the analysis should be undertaken as a relative quantification using a benchmark approach with sensitivity analysis. However, the analysis will incorporate the vehicle-track interaction view to obtain whole system related results. The results should support LCC analysis in order to improve on current whole life cost values such that they can be significantly improved upon.

In parallel, further developments and trials will be conducted on existing switch and crossing designs, to implement outputs from previous EU funded projects that may have early benefit to the existing systems. The work stream will manage heterogeneous measures (the monitoring data of old and new S&C).

This approach is conceptualised in the decision process diagram. The top process is the more incremental change on the existing system, within TD3.1, and the bottom is the next generation innovation work stream for TD3.2.

**Figure 62: Switch & Crossing Technology Development Process**

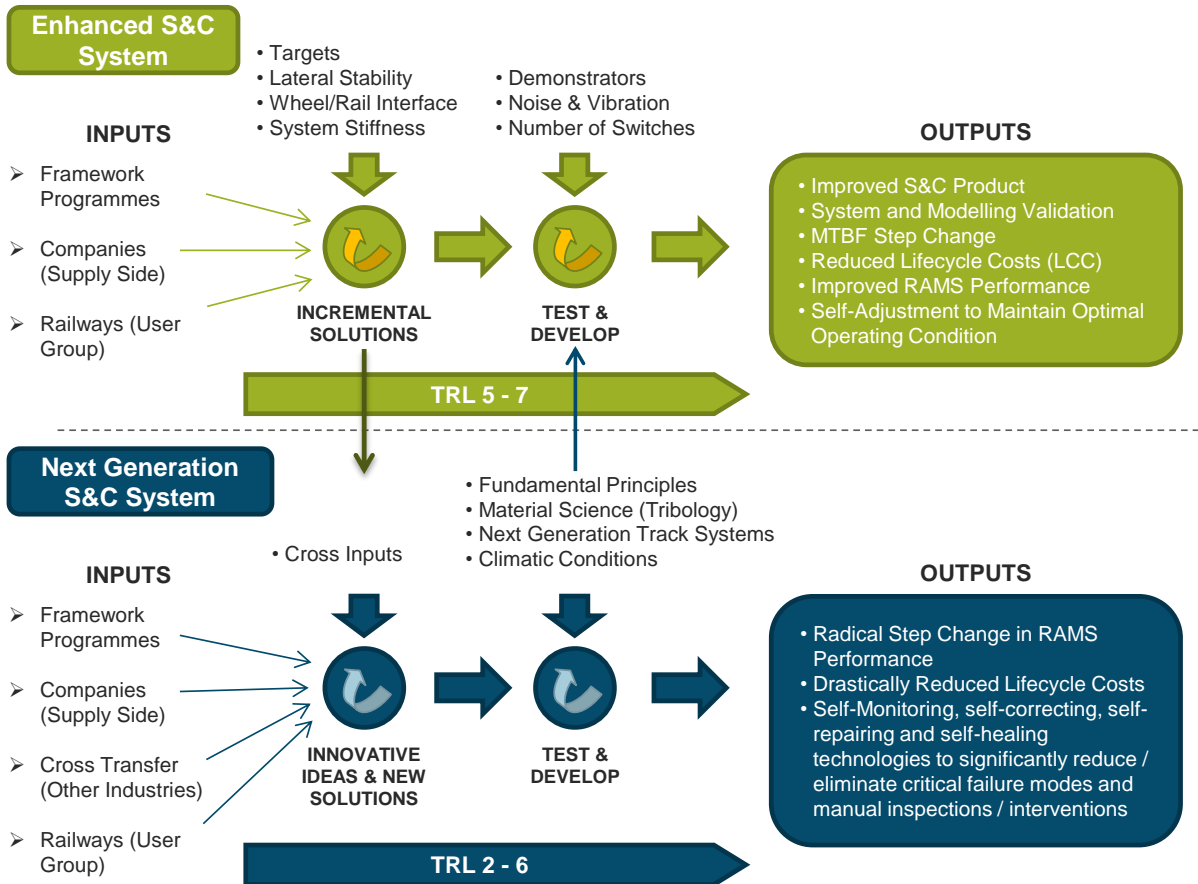

**High-Level Task Breakdown**

Task	Task Name	Task Description	Lighthouse Project Contribution (% / Budget €m)
Task 3.1.1	<b>Identify Best Practices for S&amp;C</b>	<ul style="list-style-type: none"> <li>Collate existing knowledge on Switches &amp; Crossing (S&amp;C) to identify best practice concepts.</li> <li>Complete knowledge transfer from existing EU and international research projects.</li> <li>Collate existing EU knowledge and experience relating to product development, manufacturing, testing, installation, operation and maintenance of S&amp;C.</li> <li>Provide detailed analysis of existing S&amp;C components and system integrity, tribology and RAMS performance.</li> </ul>	In2Rail (10% / 0.10)
Task 3.1.2	<b>S&amp;C High Level Upgrade Specs</b>	<ul style="list-style-type: none"> <li>Establish fundamental S&amp;C operating principles.</li> <li>Develop and propose S&amp;C system and sub-system high level upgrade specifications.</li> <li>Develop new switch actuation principles, locking mechanisms and detection device designs.</li> <li>Develop new S&amp;C system specifications for embedded and integrated sensors.</li> </ul>	In2Rail (26.4% / 0.66)
Task 3.1.3	<b>Modelling, Trialling and Testing of small scale objects</b>	<ul style="list-style-type: none"> <li>Develop whole system S&amp;C modelling capability.</li> <li>Creation of system design models and material/component preliminary designs.</li> <li>Compare modelling data with existing field trials data sets and data generated in the laboratory</li> <li>Developing virtual mock-ups to test and assess different designs.</li> <li>Manufacture S&amp;C sub-systems for testing and assessment within a laboratory environment.</li> <li>Performance in laboratory tests (e.g. according to friction and wear).</li> </ul>	In2Rail (2.5% / 0.10)
Task 3.1.4	<b>In-track full scale test and assessment</b>	<ul style="list-style-type: none"> <li>Develop test methodologies and procedures for full scale site testing.</li> <li>Organisation and technical validation of full scale system testing.</li> <li>Specify additional specialist instrumentation and technical logistical support of in-track full scale testing.</li> <li>Perform in-track full scale test and assessment of S&amp;C system and sub-system improvements as part of an Integrated Technology Demonstrator.</li> <li>Validation and correlation with lab tests in 3.1.3</li> </ul>	N/A



Task	Task Name	Task Description	Lighthouse Project Contribution (% / Budget €m)
Task 3.1.5	<b>Performance Data Gathering and Assessment</b>	<ul style="list-style-type: none"> <li>Completed detailed data analysis of actual performance and previous reliability predictions of sub- systems and components.</li> <li>Perform detailed LCC data analysis.</li> <li>Provide additional specialist analysis of production manufacturing/logistics, installation equipment and materials handling requirements.</li> </ul>	N/A

**Note:** ⇨ Indicates areas that are foreseen to be covered by Open Calls.

**3.5.1.6. Planning and budget**

**TD3.1 Gantt Chart**

TD3.1 - ENHANCED S&C SYSTEM		2015				2016				2017				2018				2019				2020				2021				2022				2023				2024			
Task	Description	Q1	Q2	Q3	Q4	Q1	Q2	Q3	Q4	Q1	Q2	Q3	Q4	Q1	Q2	Q3	Q4	Q1	Q2	Q3	Q4	Q1	Q2	Q3	Q4	Q1	Q2	Q3	Q4	Q1	Q2	Q3	Q4	Q1	Q2	Q3	Q4				
3.1.1	Identify best practice for S&C																																								
3.1.2	S&C high level upgrade specifications																																								
3.1.3	Modelling, trialling, & testing small-scale objects																																								
3.1.4	In-Track full-scale tests and assessments																																								
3.1.5	Performance data gathering and assessment																																								

**TD3.1 Budget**

The estimated budget for the TD is around 15.5M€.



### 3.5.2. TD3.2 Next Generation Switch & Crossing System Demonstrator

#### 3.5.2.1. Concept and objectives of the Enhanced Switch & Crossing System Demonstrator

##### Context

The competitive nature of today's world markets places even more emphasis on the rail industry to become more efficient and have a stronger presence in a trans-European and global context. The European rail industry must accelerate its efforts to stay relevant in this emergent global commercial environment, in order to contribute to the success of the economies within the European Union.

A number of key components within the traditional railway system are particularly vulnerable to failure, the consequences of which are profound to the overall performance and safety of the railway infrastructure. One such element is Switch and Crossing (S&C) assemblies the fundamental design principles of which have remained unchanged since their inception, and currently account for 25-30% of all infrastructure failures on most European railway networks. The duty cycle on rails are arduous and complex and advances in rail steel technology needs to be developed to resist abrasive wear and rolling contact fatigue.

This Technology Demonstrator (TD3.2) aims to provide radical new system solutions that deliver completely new methods for directing trains to change tracks.

TD 3.2 will adopt a structured R&D process to achieve of the TD through Innovation to achieve the objectives. The approach will draw upon other spheres of industry that have successfully addressed the problem of gaining improvements beyond conventional incremental development.

The radical new designs will embrace new methodologies of switching trains between tracks in a manner that drastically improves capacity, performance and reduces costs whilst maintaining safety as an over-riding consideration. Advances in materials, enhanced elastomeric components, optimised sensor technologies, adaptive control with active control closed loop feedback providing self-adjusting/self-compensation will all be incorporated to significantly lower overall whole life costs. A number of possible new S&C designs will be created that are not constrained by the principles imposed by the common design features that are intrinsic to all current design variants. One new design will be selected from these new designs for full prototype development.

TD 3.2 will also consider the development of 'nano' technology applied to metallurgy and associated 'self-healing' properties; as well as the use of composite and other non-ferrous combinations where it is considered to be beneficial. In parallel, friction modifiers and lubrication systems will be provided to cope with new technologies and harsh environmental conditions (e.g. sand, ice). The objective is to increase the operational capacity of European networks in response to the EU Transport White Paper and the ERRAC targets, while at the same time track possession times and total track maintenance cost are to be minimised.

Interaction with other TDs (within the same IP or other IPs):

- IP1 – TD1.4 Running Gear
- IP2 – TD2.11 Smart radio-connected all-in-all wayside objects



- IP3 – TD3.1 Enhanced Switch & Crossing System
- IP3 – TD3.3 Optimised Track Systems
- IP3 – TD3.4 Next Generation Track Solutions
- IP3 – TD3.6, TD3.7 and TD3.8 Intelligence Asset Management
- IP5 – TD5.3 Wagon Design

Attention and interaction will also be performed with the transversal subjects of:

- Energy
- Noise and Vibration
- Assessment

#### **Definition and justification of the objectives**

In line with the objectives of the research area ‘Next Generation Switch and Crossing Systems’, Technology Demonstrator TD3.2 will deliver new system solutions that examine completely new methods for allowing trains to change tracks in a manner that radically improves capacity, performance and reduce costs whilst maintaining safety as an overriding consideration.

The next generation S&C system, with improved sensor capabilities for self-diagnostics and the ability to self-adjust, self-correct, self-repair and self-heal, will deliver a significant enhancement of RAMS performance. Noise and vibration characteristics will also be enhanced while at the same time allowing for improved maintainability and reduced Life Cycle Costs.

Objectives, results and related deliverables of TD3.2 are summarised in the following table:

Objectives	Results	Deliverable
Increased availability through less complexity	Reduction of failure modes leading to improved reliability and availability	Specification, development and demonstration of S&C based on technology transfer
Increased availability and reduced life cycle cost	Improved sensor system creating real time asset up to date information	Specification, development and demonstration of the intelligent assets and maintenance
Lower LCC through Improved design	Reduction in corrective and preventative maintenance through predictive maintenance and 'self-healing'	Specification, development and demonstration of more reliable technologies and interfaces
System approach to deliver improved capacity, LCC and availability	Development of mechatronic principles	Specification, development and demonstration new way of rolling stock steering to change tracks. A sensor system embedded within the whole system design will allow for self-inspecting, self-adjusting, self-repairing and self-healing capabilities. A mechatronic S&C design will reduce disturbances in operations due to maintenance optimisation, supported by elastomeric components.
Improved competitiveness and green footprint that addresses environmental factors	Improved peak noise behaviour when vehicles transition through the unit. Reduced energy resources for manufacture and maintenance	New track components and materials (PUR elasto-plastic materials, bearer concepts, surface coatings, lubricants, etc.) together with self-adjustment keeping the equipment in optimal working condition. Enhanced noise and vibration performance will also lead to increased acceptance of rail traffic in urban areas, thereby allowing increasing capacity.
Improved sustainability	Inherently weather resilient	Avoid the need for retrofit, inefficient point heating systems through a robust S&C system that is designed and tested to realistic environmental extremes.
Cost reduction	New architectures, technologies and tools to reduce cost during manufacturing, integration and commissioning phases	Specification, development and demonstration of the next generation of S&C, with fewer and more reliable components, more flexibility and modularity, and easier integration and commissioning procedures.



### **Alignment to S2R Strategic Master Plan**

The specific benefits above have a major impact on the Shift2Rail system-level KPIs. The strategic outcomes of TD3.2 are foreseen as:

- S&C Track forms that last 60 years and significant reduction or elimination of maintenance & renewals costs;
- Self-healing and lubricating rail steel (nano technologies);
- New Switch and Crossing reduce failure and maintenance costs;
- New Switch and Crossing reduced peak noise generated by S&C relative to track -3dB;
- Alignment of IM system and design resources and targets with suppliers will ‘quadruple’ both the effort and funding to generate the radical solutions;
- Solutions are validated and tested to extremes; and
- Generates solutions for low cost maintenance and renewal, 24/7 working and improved safety of track workers.

#### ***3.5.2.2. Technical ambition of the Enhanced Switch & Crossing System Demonstrator***

##### **Ambition**

Existing S&C related system failures account for >25% of all infrastructure failures on European railways. The new switch and crossing system will seek to significantly reduce and/or eliminate these failures by achieving ‘step change’ improvements. The following major topics will be covered throughout the duration of TD3.2:

##### *Next Generation Design, Materials & Components*

S&C rely on standard profiles that are machined to the specific shapes as required by the S&C configuration. Traditionally, the design application engineering is different across European railways. Modern S&C strives for predictable wear resistant steel properties that can be maintained in an efficient way. To progress beyond the current state of the art, TD3.2 will examine technology transfer opportunities from other industries as well as developing bespoke materials science solutions. The wheel-rail interface will be optimised to enable the development of radically new mechanisms for switching a train from one line to another.

##### *Next Generation Kinematic and Electrification Systems*

Existing S&C systems still use historical design features originally intended for hand operation. Modern actuators and motors deliver increased switch actuation forces, which can reduce the asset operational life. The next generation S&C design will incorporate a completely new switching function using novel kinematic elements with radically different components and will be designed from a whole system perspective. The new design will also affect the failure modes of track circuits and TD3.2 provides an opportunity to integrate improved train detection with fewer or zero electrical





failure modes. There will also be improved physical protection to components required for track circuit functionality.

#### *Next Generation Control, Monitoring and Sensor Systems*

Existing S&C systems do not utilise sophisticated sensor systems with feedback control loops. New control methods will offer real time functional status reporting and preventative intervention control. Through new technology development and transfer from other industries, the next generation S&C design will incorporate intelligent self-diagnostics systems with the capability to self-adjust, self-correct, self-repair and self-heal within predefined system operating tolerances. The next generation S&C system will significantly reduce manual maintenance interventions through 'self-management'.

#### *Towards Maintenance and Degradation Free S&C*

It is vital that the S&C unit has a stable spatial position over time and the correct support conditions to counter the dynamic forces it will experience over its operational life. It is common that the S&C is treated as an extension of the normal plain line track system utilising the same design and construction techniques. The next generation S&C design will allow for a different approach to the S&C support elements and will be designed together as a whole system.

#### **Market Uptake**

By the end of the proposed work, all the principal elements required for rapid market uptake will have been achieved. These include:

- Demonstration of technologies in a real operation environment that provide objective measures and hence give credibility and clearly show benefits.
- Products and systems that are developed for easy and high quality manufacturing.
- Solutions designed to be simple to operate, easy to maintain, completely interoperable and full inter-compatibility, allowing for effective and efficient supplier competition.
- Shift2Rail will provide products and systems that have been independently assessed for compliance with European standards and requirements giving confidence to Infrastructure Managers and permitting rapid deployment.
- Shift2Rail will be able to provide evidence for successful system integration of the products greatly helping Infrastructure Managers to gain trust in the innovations and products.
- With the infrastructure managers as part of Shift2Rail the products will come with a pedigree of end users needs having been properly addressed
- Reliable and accurate Life-Cycle Cost information provided with the products will help with technology introduction and the case for rapid deployment into the railway system.



- The Shift2Rail development will stimulate new product introduction, allow for the supply chain to manage the risk better and allow longer warranties to be issues in line with the construction industry thereby greatly helping product acceptance and deployment.

### Technical Ambition TD3.2

The following table summarizes how this TD will progress the state-of-the-art and overcome today's limitations:

State-of-the-art	Advance Beyond State-of-the-art (Shift2Rail)
<p><b>Installation</b></p> <p>Installation of S&amp;C requires many steps and manual actions to locate the unit in its position.</p>	<p><b>Installation</b></p> <p>A switch unit designed for automated installation and maintenance.</p>
<p><b>Maintainability</b></p> <p>Current design is labour intensive and requires maintenance staff to tend to the assets at regular intervals to survey its state as well as to make adjustments and refill consumables.</p>	<p><b>Maintainability</b></p> <p>Embedded remote sensors reduce manual condition surveys. Adjustments will be automatic as far as possible and the design will not require consumables.</p>
<p><b>Availability</b></p> <p>Within existing switch panel designs, the switch rails are one of the highest loaded components within the S&amp;C system and are therefore significantly affected by wear, fatigue fracture and Rolling Contact Fatigue (RCF).</p>	<p><b>Availability</b></p> <p>S&amp;C with increased availability through reduced complexity and being designed for degradation resistance and the ability to resist and/or remove dynamic forces.</p>
<p><b>Operational</b></p> <p>Existing points operating equipment (POE) may incorporate sensors that work independently to the whole system. For example, the relationships between drive forces, system lubrication and switch position cannot be automatically assessed and hence whole system condition is not known until a comprehensive manual inspection is complete.</p>	<p><b>Operational</b></p> <p>The next generation S&amp;C design will include an integrated and intelligent self-diagnostics system to enable self-adjustment, self-correcting, self-repairing and self-healing capabilities. New, advanced materials will also be used to significantly reduce asset degradation. Nano-technologies for self-healing materials are already in development and, subject to technology maturity, will be used within both the switch and crossing panels.</p>
<p><b>System Degradation</b></p> <p>Currently the solution of making the vehicles change direction is solved as part of the infrastructure causing wear and tear and failure modes to be associated with these locations.</p>	<p><b>System Degradation</b></p> <p>The proposed S&amp;C system will consider alternative vehicle guidance techniques with the aim of removing (or significantly reducing) system degradation and critical failure modes. This will improve LCC and enhance safety and reliability through fewer and less invasive maintenance interventions. This aim will be to work towards zero maintenance interventions.</p>
<p><b>Life Cycle Cost</b></p> <p>The current S&amp;C design has been designed by considering existing materials, computers, electronics and mechanics in mind but not from a whole system perspective. As a result, the existing state-of-the-art solutions have, in many ways, not been optimised with regards to RAMS and procedures.</p>	<p><b>Life Cycle Cost</b></p> <p>New architectures, technologies and tools to reduce cost during engineering, integration and commissioning phases. Fewer and more reliable components, more flexibility, elasticity and modularity, and easier integration and commissioning due to CAE methods.</p>
<p><b>Assessment</b></p> <p>Individual time-consuming assessment processes for new S&amp;C systems for individual railway operators.</p>	<p><b>Assessment</b></p> <p>Guidelines and procedures for hybrid assessment (virtual + experimental) and cross acceptance for new materials, components and systems.</p>



### **Technical Limitations/Barriers**

The barriers to innovation in Shift2Rail include many themes and may be **[P]**olitical, **[Ec]**onomic, **[S]**ocietal, **[T]**echnological, **[L]**egislative, **[En]**vironmental in their nature. The same barriers and obstacles (see below) that related to TD 3.1 may also impact the level of market uptake for solutions developed within TD3.2:

- Lack of investment in less profitable lines reduces uptake of innovative solutions **[P]**;
- Restricted investment capital is a barrier to selecting optimised LCC option **[Ec]**;
- Existing long term contracts and framework agreements restrict rapid uptake of new technology **[Ec]**;
- Resistance to change due to culture and competence through ‘patterning’ (forming of fixed ways of behaving) **[S]**;
- Current decision making sometimes based on subjectivity rather than actual data analysis **[S]**;
- Current ways of working not consistent across Europe, increases difficulty in making a universal incremental change or step-change **[S]**;
- Legacy systems in most of EU countries and lack of harmonisation are an obstacle for interoperability **[T]**;
- European disparity in technological level **[T]**;
- Regulatory/legal barriers around introducing new products and techniques – i.e. national notified rules; national product acceptance processes; national standards; and specifications **[L]**; and
- Climatic variation across Europe affecting compatibility, interoperability, and standardisation **[En]**.

### References to existing EU funded research projects

Potential synergies can be found with the following FP6, FP7 and H2020 EU-funded research projects:

Acronym (EC Reference)	Description of Project
<b>IN2RAIL</b> (GA 635900)	IN2RAIL is to set the foundations for a resilient, consistent, cost-efficient, high capacity European network by delivering important building blocks that unlock the innovation potential that exists in Shift2Rail
<b>AUTOMAIN</b> (GA 265722)	Research results on mechanised track maintenance and inspection (tamping and grinding); LEAN analysis of working methods and processes to reduce possession times; demonstration of advanced switch monitoring; decision support tool for maintenance planning and scheduling
<b>CAPACITY4RAIL</b> (GA 605650)	Research work on infrastructure, train dispatching and timetable planning and monitoring. Recommendations for Open-Source and Open-Interface for advanced railway monitoring applications
<b>D-RAIL</b> (GA 285162)	Cost efficient measures to reduce derailments (setting limit tolerances).
<b>INNOTRACK</b> (GA 31415)	Analysis of major track cost drivers to reduce maintenance costs for sub-structure, track, S&C including LCC and logistics aspects
<b>INTERAIL</b> (GA 234040)	Integrated high speed inspection system based on a modular design
<b>MAINLINE</b> (GA 285121)	Life cycle assessment tool and findings regarding modern technologies for track, tunnels and bridges
<b>SAFTInspect</b> (GA 314949)	The SAFTInspect project aims to enable efficient in-service sub-surface inspection of manganese rail crossings by applying an ultrasonic inspection technique called Synthetic Aperture Focusing Technique (SAFT).
<b>SUSTRAIL</b> (GA 265740)	Optimised track and substrate design and component selection to increase sustainable freight traffic as part of mixed traffic operations

#### **3.5.2.3. Specific Demonstration activities and contribution to ITDs/SPDs**

##### Vision:

The vision for the TD3.2 Next Generation S&C System Technology Demonstrator is to seek, by trialling, the radical redesign of S&C. The radical long-term redesign will build on the improvements achieved in the TD3.1 – Enhanced S&C System Demonstrator.

Figure 63: Relationship of TD3.2 with other TDs

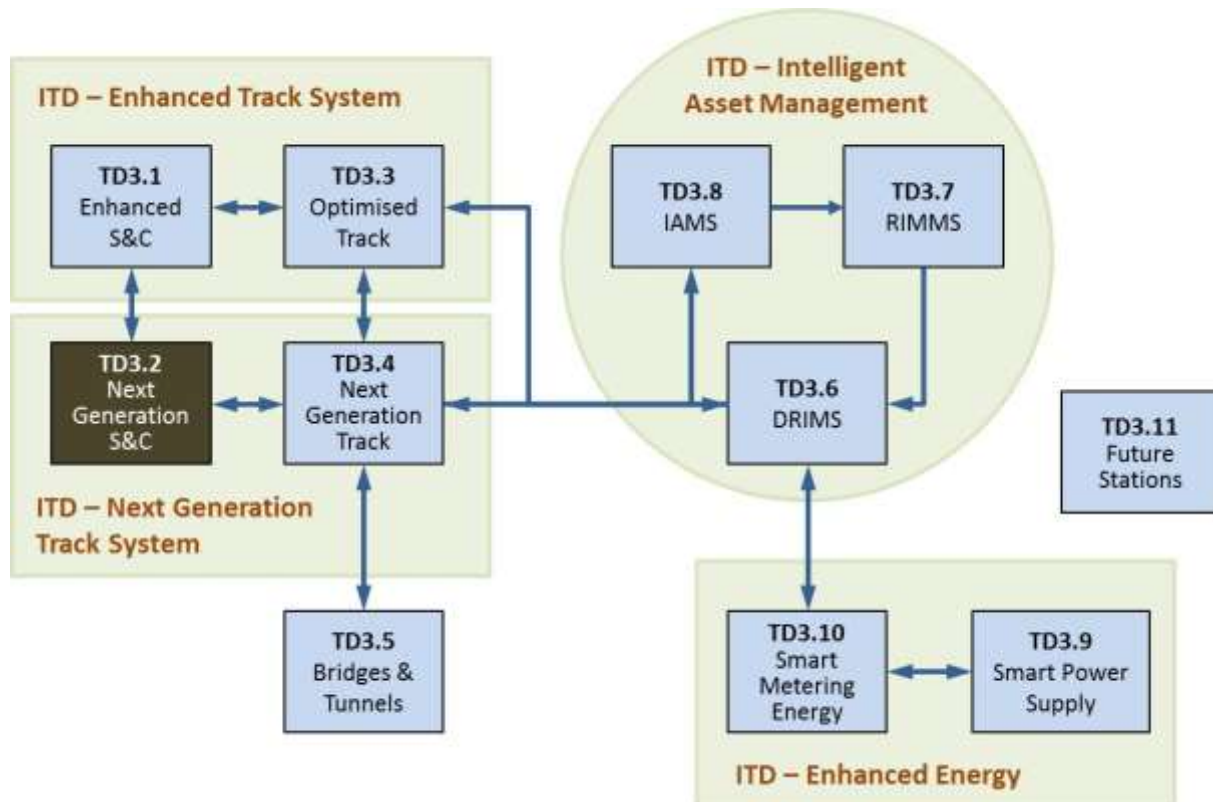
**Approach:**

The TD3.2 work stream will follow a two stage test and validation process:

**1. Small Scale Prototypes and Virtual Testing (TRL 5)**

Design and build a series of small scale prototypes to evaluate a number of radically different options for future S&C systems. The evaluation phase will enable the project to focus on the most promising options. These will then be developed into full-scale prototypes for trialling within a suitable railway test environment. Due to the advanced nature of the next generation S&C solution, it is anticipated that there will be a heavy reliance on both virtual and laboratory testing.

**2. Full-Scale Prototypes and Virtual testing (TRL6)**

The full-scale test phase will confirm safety and performance of the proposed design. Once confirmed, a full-scale accelerated life test will be conducted to understand wear, friction, damage, maintenance and whole life needs of the new design. When confidence has been established that a viable design has been achieved, a preliminary safety case will be established for the proposed design in preparation for future full-scale tests in service operation conditions within main line railways. It is anticipated that, due to the advanced nature of the next generation S&C design, there will be a heavy reliance on both laboratory and virtual testing.

The full-scale test will form part of an Integrated Technology Demonstrator (ITD) alongside TD 3.4 – Next Generation Track Systems and will link to TD3.6, TD3.7 and TD3.8 – Intelligence



System Maintenance. It is anticipated that the ITD will be hosted on a Network Rail test track facility that has been upgraded to represent realistic operational conditions.

#### ***3.5.2.4. Impact of the Enhanced Switch & Crossing System Systems Demonstrator***











##### **Benefits**

The opportunities from TD3.2, assuming TD1.4 train design achieving the weight and mechatronic bogies, are:

- Track forms that last as long as sleepers, reduction in Infrastructure Managers Maintenance & Renewal costs;
- New Materials capable of self-healing and lubricating rail steel;
- New Switch and Crossing design capable of reducing failures, maintenance costs;
- New Switch and Crossing reduces noise;
- Optimisation of track support conditions through tailored stiffness transition zones;
- Alignment of Infrastructure Managers system and design resources and targets with suppliers will 'quadruple' both the effort and funding to generate the radical solutions;
- Solutions validated and tested to extremes that IMs and industry cannot do on their own;
- Generate solutions for low cost Maintenance & Renewal; and
- Generate solutions for 24/7 working while improving safety of track workers.

### Technical impact

The following technical impacts are envisaged by the implementation of TD3.1 and have been developed in the context of the three specific Shift2Rail global targets:

Impact type	Shift2Rail Impact	Contribution to KPIs (large spot=high contrib.)
<b>100% Capacity Increase</b>	Improved RAMS performance (Reliability, Availability, Maintainability and Safety) of S&C through optimised S&C whole system design.	
	The next generation S&C will create a set of wheel interaction conditions that significantly reduce wheel dynamic forces thus reducing damage to vehicle bogie components.	
	Increased reliability through better design, implementation and monitoring of S&C.	
	The operational performance of equipment to enable train to move between tracks will be significantly improved by reducing failures and the need for maintenance.	
<b>30% Reduction in LCC and Increased Safety</b>	The new S&C will be less energy intensive to manufacture and allow for recycling in accordance with the principles of Sustainable and green asset management.	
	New systems will offer optimised whole life cost for rolling stock and infrastructure elements	
	The new systems will be designed for automated manufacture enabling low cost production measures to be implemented. It will also include reduction in the number of components embodied in a compact system design.	
<b>50% Increase in Reliability &amp; Punctuality</b>	Rolling stock components will have a reduced duty cycle exposure due to reduced dynamic track forces and hence alternative materials and optimisation of strength and weight could be achieved.	
	The new design will incorporate new aspects of maintenance free operation and also optimise any residual maintenance activities and resilience against environmental operating conditions.	
	An intelligent sensor system will be embedded within the next generation S&C system design to able the system to 'self-manage' with respect to system setup, adjustment and maintenance.	
	The improvements in S&C will reduce the forces transmitted to the rolling stock and hence failure modes associated with bogies and other train borne sub-systems.	

### Contribution to TSI/Standards

TD3.1 is expected to propose changes to existing TSIs or the generation of new TSI requirements and will actively target the closure of relevant open points. The improvements and knowledge gained is expected to influence best practice in S&C implementation, operation and maintenance. Standards relating to these areas may be influenced and changed in due course. As a brief non exhaustive list of

















Standard types on a National and International level that might be affected are Standards for S&C, Track, Ballast, installation, inspection and maintenance. Industry standards and company standards will not be targeted.

However it is possible that TD3.2 will raise issues that are pertinent to the new S&C system that may require the scope of current TSIs to be modified.

### **Strategic impact**

A summary of the strategic impacts produced by the implementation of the TD results and discoveries is given below. This is organised along three main aspects: the support to the competitiveness of the EU industry, the compliance with the EU strategic objectives, and the degree of maturity of the solutions envisaged to be realised and put into practice in the railway sector. This is expected to provide an overview of the effects generated at larger scale by the application of the TD results.

Impact type	Shift2Rail Impact	Contribution to KPIs (large spot=high contrib.)	
<b>Support the competitiveness of the EU industry</b>	<b>Global technological leadership</b> supported by a combination of innovation and technical standards, setting an effective advantage for the European industry:		
	<ul style="list-style-type: none"> <li>Whole system S&amp;C modelling used to eliminate failure modes through design.</li> </ul>		
	<ul style="list-style-type: none"> <li>S&amp;C with intelligent self-diagnostics and automated self-repairing, self-correction, self-adjustment and self-healing technologies.</li> </ul>		
	<ul style="list-style-type: none"> <li>Optimised wheel-rail interface conditions to eliminate detrimental dynamic loading.</li> </ul>		
	<ul style="list-style-type: none"> <li>System integrated redundancy within safety critical systems for optimal system reliability.</li> </ul>		
	<b>Increase attractiveness and competitiveness:</b>		
	<ul style="list-style-type: none"> <li>Increase of operational reliability (less service disruptions) through more robust systems based on less physical components, enhanced assessment and debugging concepts, and more flexible processing of information.</li> </ul>		
	<ul style="list-style-type: none"> <li>Asset Lifecycle Cost (LCC) reduction through virtual assessment, lower physical complexity of systems and optimised RAMS performance.</li> </ul>		
	<ul style="list-style-type: none"> <li>Support capacity increase because of significantly reduced and / or eliminated service affecting failures.</li> </ul>		
	<ul style="list-style-type: none"> <li>Whole system automation of S&amp;C inspection and intelligent self-diagnostics, repair and healing will remove the need for staff to be on the track (improving safety and maintenance efficiency) by eliminating the need for manual inspection.</li> </ul>		
<b>Enhanced customer experience:</b>			
<b>Compliance with EU objectives</b>	<ul style="list-style-type: none"> <li>Improved customer ride quality through optimised wheel-rail interface conditions.</li> </ul>		
	<ul style="list-style-type: none"> <li>Promotion of modal shift:</li> </ul>		
	<ul style="list-style-type: none"> <li>A big impact brought by the implementation of these new technologies towards avoiding service disruptions and adding new capabilities.</li> </ul>		
	<ul style="list-style-type: none"> <li>Improving S&amp;C 'green' credentials through minimising LCC and increasing asset life, performance and availability through whole system design whilst considering manufacturability and maintainability. The carbon footprint of S&amp;C can be reduced through optimised integration between sub-systems and automated self-diagnostics, self-repairing, self-correcting, self-adjusting and self-healing technologies.</li> </ul>		

Impact type	Shift2Rail Impact	Contribution to KPIs (large spot=high contrib.)
	<ul style="list-style-type: none"> <li>Supporting fair and efficient supplier competition and enhanced interoperability through inter-changeable solutions fitting a common component or component assembling. This will also support achieving a Single European Rail Area (SERA).</li> </ul>	
	<ul style="list-style-type: none"> <li>Support to capacity increase by integrating redundancy into system design and hence reliability to existing S&amp;C systems. In turn, this will significantly reduce and / or eliminate service affecting failures, enabling the rail infrastructure network to run at an optimised capacity level.</li> </ul>	
<b>Degree of maturity of the envisaged solutions</b>	Currently, most of the proposed technologies are at low Technology Readiness Levels (TRL) of between 1 and 2 (i.e. principles observed and the possibility of using them formulated). At the end of Shift2Rail, it is expected that the successful concepts are brought to TRL 6 (i.e. technology demonstrated in relevant environment).	

### 3.5.2.5. Implementation of the work programme

#### Overall approach and methodology

The proposed work stream will seek to develop a radically different concept of switch and crossing design, moving away from the traditional moving switch blades to a new concept of train direction changing. The proposed work plan will involve two interlinked, but parallel work plans for TD3.1 and TD3.2, whilst collaborating with TD1.4 and TD3.4.

The TD3.2 long term work stream will also be divided into a number of phases, as follows:

- Examination of existing known novel designs and conduct design scrutiny against system requirements;
- Review cross industry research;
- Development of new concept designs for evaluation;
- Section of new design for further evaluation;
- Design development and theoretical modelling;
- Prototype development;
- Rig Testing; and
- Trial implementation.

The interactions between TD3.1 and TD3.2 are illustrated below in a two stage approach:

**Figure 64: TD3.1 and TD3.2 Two Stage Approach**

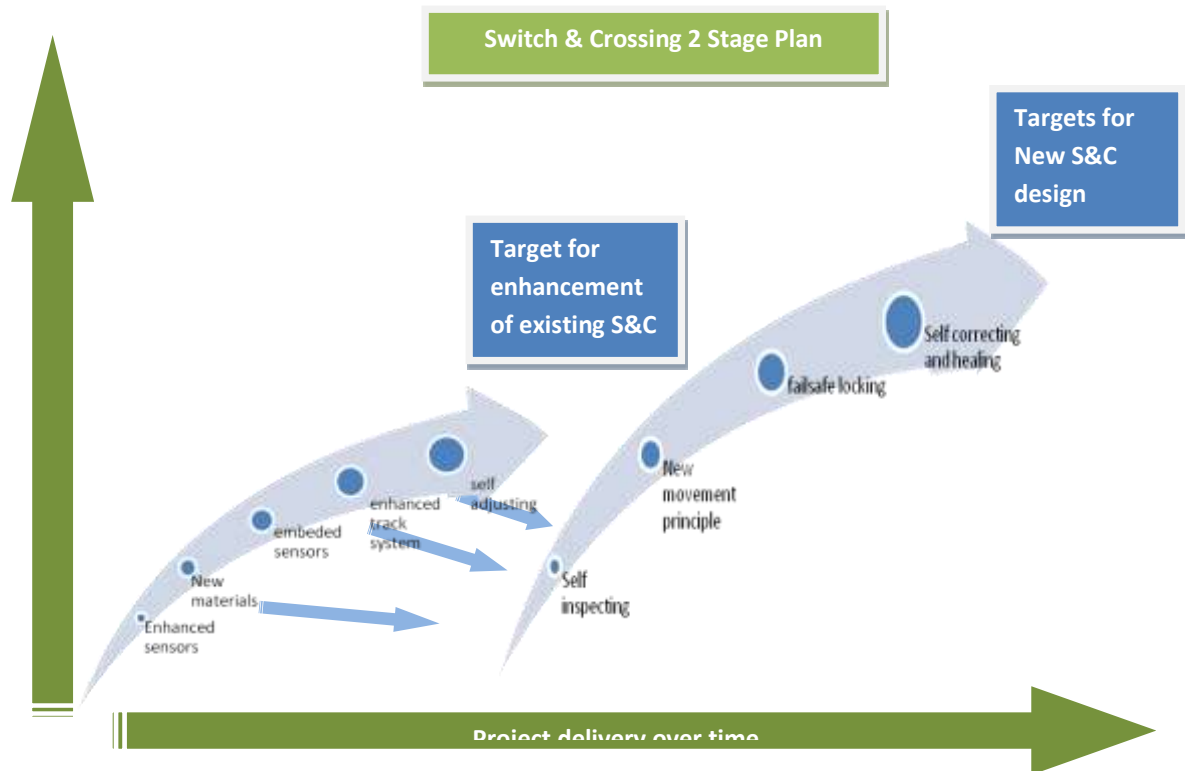

The project will review the historic culture of signalling and how it interacts with switch operation including maintenance philosophy together with TD3.8 (ISMES), with a clear plan to develop and propose a new philosophy of allowing automatic self-adjustment techniques to maintain positional safety limits. This would significantly reduce the need for regular testing. Links will also be made with remote monitoring as part of TD3.7 RIMMS. An effective asset management regime covered by TD3.6 DRIMS will also provide an integrated approach that will reduce cost and improve performance.

The most promising designs will then be taken forward to a structured work plan of testing and development of the final new concept. It is then proposed that a limited number of final designs will be selected for full development and testing.

The new S&C system will be designed with embedded sensors to enable automatic self-adjustment and condition measurement through RIMMS, which will be fully readable by railway monitoring systems. The data would feed into the intelligent maintenance System DRIMS (TD3.6) and enable 'predict and prevent' maintenance scheduling through the decision and process support system ISMES (TD3.8). Most of the maintenance data and information will be open standard and transferable across the industry.



These new methods and the new locking philosophies will take applications and machine science already in use in other sectors (*e.g.* aerospace, automotive and defence) and transfer this technology and techniques into the railway sector.

The next generation S&C system will be designed to be robust for all climatic conditions. It will attempt to characterise the current monitoring of the existing switches and crossing to allow a proper interpretation of measurements in different environmental conditions. The work stream will manage heterogeneous measures (the monitoring data of old and new switches and crossing).

The work stream will consider, from first principles, the interaction with the vehicle and the substructure and will consider the overall stiffness requirements of the S&C system (including substructure stiffness requirements, transition zones, elastomers like baseplate pads, under-sleeper pads and sub ballast mats, etc.) given that the S&C area of the railway will get less access for maintenance. The work will seek to produce a business justification for an enhanced substructure for S&C.

These potential new solutions will remove a number of the present failure modes and enable significantly higher performance. The final solution(s) will be developed from small-scale models through to full-scale prototype trials to prove performance and safety.

The design will also include new construction techniques and technologies that apply advances in material science for stabilising track forms. This overall approach is conceptualised in the technology development process diagram below (Figure 65) and also shows the interaction between the step change envisaged in TD3.2 and the progressive incremental improvement embodied in TD3.1.

Figure 65: Switch &amp; Crossings Technology Development Process

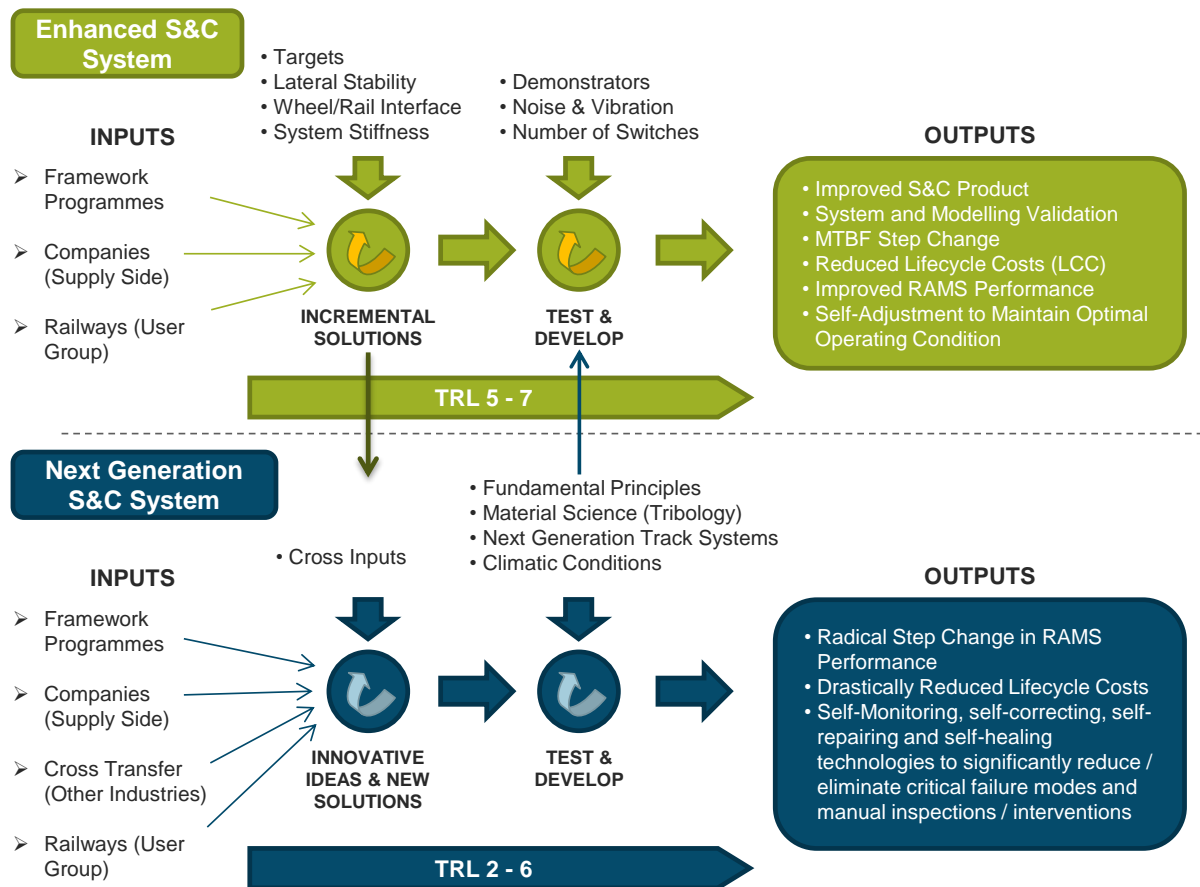

### Overall strategy and general description

The vision of TD3.2 is to provide a design that fits various track configurations and is scalable across a range of speeds, tonnages and geometries.

The developed system is also to be future proofed in terms of compatibility with potential 'mechatronic' type bogies that would not be wholly reliant on wheel contact conicity parameters.

The developed system would by design be low maintenance and high reliability and embrace the three pillars of sustainability hence ensuring that social, economic and environmental requirements are satisfied.

### High-Level Task Breakdown

Members will collaborate in order to ensure the availability of the relevant complementary expertise and to ensure a wider market uptake of the solutions by the clients. Where relevant, the areas where the participation of other entities from

Task	Task Name	Task Description	Lighthouse Project Contribution (% / Budget €m)
<b>Task 3.2.1</b>	<b>Mechatronics development</b>	<ul style="list-style-type: none"> <li>Establish fundamental principles for 'Mechatronics' S&amp;C defining safety and performance requirements and outline designs.</li> <li>Establish special constraints and principles of modular design.</li> <li>Conduct technology transfer analysis and specialist cross industry collaboration.</li> <li>Conduct methodological product development supported by inter-sectorial technology transfer.</li> </ul>	In2Rail (20% / 0.20 €m)
<b>Task 3.2.2</b>	<b>Specifications and modelling approach</b>	<ul style="list-style-type: none"> <li>Develop next generation S&amp;C design philosophy and system specifications with emphasis on interaction with existing signalling systems.</li> <li>Specification and development of models for system simulations including mechatronics and optimal embedded sensor integration.</li> <li>Development of integration system strategy for embedded control sensors.</li> </ul>	In2Rail (33% / 0.50 €m)
<b>Task 3.2.3</b>	<b>S&amp;C high level specifications</b>	<ul style="list-style-type: none"> <li>Develop requirements definition and technical specifications for performance validation, including RAMS analysis.</li> <li>Develop next generation S&amp;C system designs, taking consideration of key design drivers (<i>i.e.</i> reduction of moving parts, tribology, self-diagnosing and adjusting switch mechanisms, self-repairing and healing technologies, significant reduction or elimination of amplified wheel/rail dynamic loads).</li> <li>Develop remote condition monitoring systems for assessing the structural health of S&amp;C, including alert and intervention thresholds to alarm before system degradation reaches critical values.</li> </ul>	In2Rail (6.8% / 0.16 €m)

Task	Task Name	Task Description	Lighthouse Project Contribution (% / Budget €m)
Task 3.2.4	<b>Trial test in controlled environments</b>	<ul style="list-style-type: none"> <li>Define test parameters and load case scenarios and validation test methodologies with respect to European traffic types and volumes.</li> <li>Complete structural and dynamic modelling to confirm the feasibility of selected concepts.</li> <li>Development and execution of trial tests in controlled environments, including sub-system environmental stress testing and performance assessments (including specialist noise and vibration performance evaluation).</li> </ul>	N/A
Task 3.2.5	<b>Small scale test for prioritised candidates and assessment of S&amp;C system and subsystem improvements.</b>	<ul style="list-style-type: none"> <li>Develop test specifications, organise site trial(s) and install / configure of test facility infrastructure.</li> <li>Complete business needs analysis tailored to prioritised candidates.</li> <li>Develop and execute full scale test for prioritised candidates at track test facility to perform assessment of next generation S&amp;C system and sub-system designs.</li> <li>Develop, execute and manage track loading measurement machines, including test reconfiguration and test vehicle maintenance.</li> </ul>	N/A
Task 3.2.6	<b>Limited assessment of assessment</b>	<ul style="list-style-type: none"> <li>Complete analysis of selected designs in order to perform assessment assessments.</li> <li>Develop a limited assessment of assessment process based on hybrid assessment (virtual + experimental) and cross acceptance for new materials, components and systems.</li> </ul>	N/A
Task 3.2.7	<b>Performance Data Gathering and Assessment</b>	<ul style="list-style-type: none"> <li>Analyse and validate test results, including economic and LCC aspects, and prepare commercial implementation programme plans.</li> <li>Develop production manufacturing/logistics and materials handling requirements.</li> </ul>	N/A



**3.5.2.6. Planning and budget**

**TD3.2 Gantt Chart**

TD3.2 - NEXT GENERATION S&C SYSTEM		2015				2016				2017				2018				2019				2020				2021				2022				2023				2024							
Task	Description	Q1	Q2	Q3	Q4	Q1	Q2	Q3	Q4	Q1	Q2	Q3	Q4	Q1	Q2	Q3	Q4	Q1	Q2	Q3	Q4	Q1	Q2	Q3	Q4	Q1	Q2	Q3	Q4	Q1	Q2	Q3	Q4	Q1	Q2	Q3	Q4	Q1	Q2	Q3	Q4				
3.2.1	Mechatronics Development																																												
3.2.2	Specifications and modelling approach																																												
3.2.3	S&C High level specifications																																												
3.2.4	Trial test in controlled environments																																												
3.2.5	Small scale tests and assessment of improvements																																												
3.2.6	Limited assessment																																												
3.2.7	Performance Data Gathering and Assessment																																												

**TD3.2 Budget**

The estimated budget for the TD is around 16.7M€.



### 3.5.3. TD3.3 Optimised Track System

#### 3.5.3.1. Concept and objectives of the Optimised Track System

##### Context

TD3.3 'Optimised track system' will fundamentally challenge track construction assumptions that are implicit in current European track form design. The objective is to explore how new construction designs can make use of modern designs and materials that provide high levels of sustainability, capacity and LCC savings relative to existing construction types. To this end, innovative solutions in the form of products, processes (e.g. plan and carry out maintenance) and procedures (e.g. establishment of technical requirements) will be required. This approach will also be applied to the renewal of existing track assets and will establish how such new designs could be applied in this implementation context. The construction methodologies will also be defined and proven by a combination of simulations and structured (field) tests.

The TD description is based on in-depth discussions with infrastructure managers in Europe to identify common problem areas and needs for development. As a result, the 'end user requirements' are established. There is also a need for flexibility not to ignore future suggestions for innovative solutions that arise from within the consortium, or as a result of open calls etc. All solutions will be developed and verified with the aspect of interaction with vehicles. To this end, the work plan is organised as a scheme to evaluate innovative solutions. Some of these innovative solutions are described in the following, whereas other will emerge as the project commences.

##### Definition and justification of the objective

The main objective of TD3.3 is to improve the operational performance of existing S&C designs. This will be achieved through the delivery of the following specific achievements from this TD:

1. Increase lifetime of track by 100%;
2. Decrease traffic disturbance due to track maintenance and faults by 50%;
3. Develop and deploy tools to allow for infrastructure managers to determine track solutions that are technically, economically, environmentally and operationally beneficial including LCC and RAMS evaluation of solutions; and
4. Deploy tools to provide the infrastructure manager with means for pro-active management that sets out from a system approach and includes all necessary components from track bed to welding.

The latter two items relate to a substantially improved precision in decisions regarding track design and investments, and in the urgent need to move further into pro-active maintenance definition and planning.

The following table summarizes some **objectives** and related deliverables of this TD:

**Table 19: Examples of objectives and deliverables of the TD**

Objectives	Results	Deliverable
Improved rail damage prevention and mitigation.	Improved materials designs and processes.	Enhanced knowledge and analysis. Optimised planning.
Need for enhanced monitoring methods.	Methods to measure and analyse physically relevant data.	Solutions tightly integrated in asset management processes.
Decreased deterioration through lubrication, grinding, and rail grade optimisation.	Optimized products and operational procedures.	Guidelines and operational recommendations.
Better resistance to climate change.	More robust track solutions.	Evaluated and integrated solutions.
Reduced time on track for on-site track works.	Improved time-saving processes, procedures and products.	Enhanced processes, procedures and products.
Current welding technologies are insufficient for future demands.	Innovative welding technologies and assessment methods.	Evaluated solutions.
Enhanced rail support and reduction of transition zones.	Site specific optimisations to reduce dynamic forces.	Guidelines and evaluated solutions.
Decreased consumption of limited natural resources and environmental footprint.	Validation and implementation of recycled and environmentally viable materials.	Evaluated solutions.
Ballasted track solutions that employ benefits of slab track.	Improved sleeper and track form solutions.	High performing and maintenance friendly track forms.
Optimise reduction of deterioration with train fleet	Better understanding of interaction with train fleet	Guidelines with clear demands on manufacturers of vehicles
Accurate and timely knowledge to improve asset management.	Integrated and intelligent monitoring and analysis of deterioration rates.	Track status module for an asset management system.
Limited knowledge on track support and settlement conditions.	Enhanced methods and data analysis.	Evaluated solutions.
Reduction of high noise and vibration levels.	Solutions including refined framework of permitted levels.	Enhanced solutions that can meet future demands.

### **Alignment with Shift2Rail Strategic Master Plan**

The project proposes to deliver outcomes which will produce a step change in how the European rail network is developed and operated, such that the track, which is the primary fundamental element of the railway system has improved economic viability and will be capable of delivering increased transport capacity with an improved reliability.

The project will be organised and managed with a programme and technical governance framework that has clearly defined stage gates and review processes. This includes short term monitoring of



progress against KPIs that will be structured to reflect the critical and most innovative aspects of the project.

#### **Overall KPIs are**

- Reduced overall LCC and enhances RAMS
- Increased track performance and decreased traffic disturbance
- Improved environmental performance

#### **More specific track KPIs are**

- Decreased occurrence/magnitude of wear and RCF on rail
- Increased track geometry performance
- Improved track stiffness including reduced stiffness deviations
- Decreased noise and vibration pollution
- Improved monitoring and validation procedures to enhance control over deterioration

Three fields where the work in TD3.3 is believed to provide societal benefits:

- Capacity
- Operational reliability
- Competitiveness

### ***3.5.3.2. Technical ambition of the Optimised Track System***

#### **Ambition**

The work in this TD aims at significantly leveraging the track system from the current state-of-the art. To this end, the current status of track technology and scopes of improvement are presented below. Note that this evaluation, and the definition of future challenges is supported by the fact that the partners involved in the TD have been involved in most relevant EU initiatives related to track structures. This means that the current research front is well known, and that future research will adopt previous project results as a basis to build from. This description follows the physical structure of the track. In addition, there are lateral topics, such as maintenance, combatting of noise emission and vibrations that are partly included in the technical sections. However the demonstrators envisaged in this TD are foreseen to include also self-standing solutions in these areas. Consequently, the state-of-the-art and foreseen development in these areas are also given a separate section.

The solutions derived in this TD will be evaluated based on LCC and RAMS performance. This process is described in detail below. To this end, LCC and RAMS-analysis procedures developed in INNOTRACK and consequently refined are being employed. It is envisaged that actual operational and capital expenditure cost data will be obtained from infrastructure managers within the Shift2Rail JU and from global rail network operators.



### **Market Uptake**

Traditionally, exploitation and possible market uptake has been a very lengthy process in the railway sector. Through the structured development of these demonstrators and their follow-up through direct cooperation between industry and infrastructure managers together with integrated testing/certification methodologies for rapid deployment this uptake time will be significantly reduced. In Task 3.2 the Railway Regulators will be informed and given the possibility to give recommendations in an early stage and advice on how the approval process can be streamlined. Finally, in Task 3.4 the European and National Safety Authorities will form a basis for final acceptance of the solutions.

### **Track technology progress beyond the State-of-the-Art**

The development of demonstrators sets out from the future demands for rail structures. These demands incorporate expectations from future operational loads, maintenance possibilities, LCC and RAMS levels, climate impact etc. From this analysis, whole-life duty requirements on future rail solutions will be extracted and all proposed rail solutions will be contrasted to these demands. This will form a basis for the final recommendation on which solutions to incorporate in the operational demonstrators. An additional aspect to consider is that the medium-term solutions need to harmonize with current solutions and regulations.

#### *Rail solutions*

Examples of rail solutions to achieve future demands that will be considered in the TD include:

- Optimised rail damage prevention and mitigation strategies for combating different types of rail damage need to be drastically improved. Currently knowledge of the nature of deterioration phenomena is significantly lacking in several areas. Influencing parameters and predictive models need to be identified and contrasted to measured operational data. Means to reduce deterioration by altering operational conditions will be investigated and contrasted towards costs. The outcome will be an optimised design, investment and maintenance plan to minimize LCC and RAMS deficiencies.
- Methods to measure stresses, RCF, geometry degradation, stiffness, friction, material defects, etc., need to be significantly enhanced from the current state-of-the-art to facilitate high-precision asset management.
- Friction management, grinding/milling, and rail grade optimisation are currently the primary means of combating deterioration. The precision in the use of these methods needs significant enhancement.
- New rail solutions to better withstand the impact from climate change (extreme weather, temperature etc.) conditions will be needed as a consequence e.g. of global warming.
- Increased traffic congestion and the resulting reduced time in track will require innovative methods for in-site rail manipulation and unloading of rails.



- Innovative welding and repair technologies including modifications and tuning to account for various technologies and operational conditions will need to be enhanced in the future.

The new solutions also demand a fundamental increase in knowledge of how different material and interface characteristics relate to rail damage, what are the operational consequences of altered materials etc. There is also a very strong link to damage in switches and crossings (TD3.1 and TD3.2) that will be employed to obtain synergy effects.

#### *Fastening/pad solutions*

The fastening and rail pad provides a stable support for the rail and transfers loads to the sleeper and track foundation. As loads and speeds increase together with the need for reliable operations this is becoming a critical part of the track system. Examples of fastening/pad solutions to achieve future demands to be considered in the TD include:

- Optimal use of rail-pads to optimise rail support stiffness. This includes non-traditional use of elastomers. Enhancements in this area will be needed to tackle the need for current local variations in track characteristics to be further adapted to a harmonized European track system.
- Re-use and recycling materials in fastenings and pads is foreseen. The knowledge in this area is currently weak. In particular an analysis of the influence of these new materials on the reduction of noise and vibrations is needed.
- Improved precision in tuning fastening systems to improve over-all load distribution and minimize deterioration. This includes investigations into high-elastic fastening systems.

#### *Sleeper and other rail support solutions*

Sleeper and similar constructions provide support for the rail and distributes load to the track foundation. It is a crucial component in deciding the overall response of the track system. As an (extreme) example one can consider the drastic change in track properties for a slab track as compared to a ballasted track. In the optimum track system solutions, one focus will be on ballasted tracks with the main aim of improving their performance by adopting benefits, while avoiding the drawbacks of slab track solutions. As an example, this includes improving track stability while retaining the access to (relatively) easy track geometry corrections. This will be an improvement required to meet future performance demands without the need to completely alter a significant proportion of European railways. A second important topic to be investigated is which rail support solutions are optimal for various conditions. This requires a significant in depth understanding of the technical characteristics of different solutions and how these translate to various forms of deterioration and eventually life cycle costs.

Examples of sleeper and rail support solutions to be considered in the TD include:

- New materials (re-use, recycling materials) in the design of rail support to increase sustainability whilst improving performance. Examples are recycled aggregates (e.g. recycled concrete or furnace slag) or recycled steel fibres to increase cracking/fatigue resistance of sleepers.



- New rail support design for the reduction of loads and increased durability and track stability. This includes integration of elastomeric elements to vibration mitigation, decreasing variations in track stiffness especially in transition zones, and increase of lifetime of ballast.
- Improved rail support design to account for altered operational demands, e.g. innovative designs to minimize the effect of flying ballast, which is an increasing problem with higher speeds.
- Fully integrated health monitoring in rail support to support an optimized asset management.
- Better characterisation of demands on rail support solutions to facilitate combinations of the best support solutions.

#### *Track support solutions*

A crucial component in this area is to improve the bearing capacity of the track support layers, which will be a significant need due to the foreseen traffic increase. Compared with today's state-of-the-art such solutions must be low cost, low maintenance and easily integrated in the construction and renewal process of both new and existing structures. Examples of solutions to achieve such goal that will be considered are:

- Use of new materials in subgrade design and upgrade. This includes re-use and recycling materials, and also precast or modified ballast that will improve the overall performance of track support. This task also includes pertinent improvements of material specifications.
- Use of enhanced geophysical methods for the study, analysis and determination of defects related to geotechnical conditions of railway substructure. Obtained data are integrated in an asset management database.
- Introduce new innovative soil treatment methods based on polymeric and waterproof materials to improve mechanical properties of the stabilized soils (form layer and natural ground).
- New solutions based on emulsion to increase and/or improve the mechanical properties of the sub-ballast layer.
- Optimized (in terms of time and employed technology) maintenance processes. One aspect is the required depth down to which actions such as tamping and ballast cleaning should be performed to obtain the desired track support improvement.
- Innovative methods to combat 'track memory', which is manifested in the fact that track geometry faults tend to occur rapidly after mitigation. There is a need to understand underlying causes, monitor these and intervene with effective actions.

#### **Progress in related topics beyond the State-of-the-Art**

##### *Noise/vibration*

Noise and vibration cause discomfort for citizens living close to the track and train passengers. Inability to fulfil legal demands can restrict train operations. These demands will be more severe in the future. To tackle the issue it is noted that if noise and vibration issues are considered early in the



design stage, they may then be mitigated by rather inexpensive actions. Thus, noise and vibration issues are a key part in the development and evaluation of all track solutions within the IP. Further, stand-alone solutions to decrease noise and vibration levels will be evaluated.

The work sets out from previous research in projects such as RIVAS, HARMONISE, SILENCE. At least four objectives are aimed for:

- Prevention of vibrations in a high frequency range to solve the problem at the source
- Damping or interception of the dispersion path in the track structure
- Passive damping/reflection/shielding of noise/vibration radiation
- Shift of the emission spectra into more 'pleasant' frequencies

Solutions to be considered in combatting noise include:

- Enhancement of noise and vibration measurement and mitigation/prevention methods. In particular there is a need to identify methods for combined assessments of noise and vibration. Further, potential solutions to derive toolboxes for an evaluation of the combined effect/cost of a of range different solutions to reach a target limit are needed. To this end, also the influence of altered demands on noise/vibration assessments (e.g. as a results of changes in legislation) need to be considered.
- Development of noise and vibration mitigation and prevention solutions including integration of solutions at the design stage, and also stand-alone solutions such as acoustic barriers. Also improved procedures to migrate from existing mitigation approaches towards prevention are needed. Examples in this area are:
  - New materials for lining and the core of acoustic barriers that increase efficiency, durability and allow easy installation and low maintenance.
  - New materials for vibration mitigation.
  - Swivelling low noise barriers that provide an easy and fast possibility of turning away the low noise barrier (for safety/maintenance reasons) and also fits better in landscapes.
  - Optimum use of under sleeper pads (USP) and under ballast mats (UBM) to reduce noise and vibration emissions.

#### *Integrated maintenance procedures*

Future demands on railways will drastically reduce time for maintenance in track. At the same time, a significant increase in maintenance levels will be needed to withstand the increased operational demands. There is thus a very high need for improved maintenance procedures. This improvement can be summarized as improvements in: Improved evaluation of needs for maintenance, improved decisions on required maintenance actions, improved performance of these required maintenance actions, and improved coordination of maintenance actions. TD3.3 will be interacting strongly with TD3.6, TD3.7 and TD3.8. In short TD3.3 here defines key operational parameters to measure and analyse, derives models to predict deterioration, establishes technical limits for acceptable





deterioration levels, evaluate technical feasibility of improved maintenance procedures, and makes consequence analyses of different maintenance scenarios. In contrast, the focus in TD3.6, TD3.7 and TD3.8 is overall data management, prioritisation and planning of maintenance actions.

Due to the significant investment installed in the current track structure the optimised track system solutions are foreseen to largely build on current technologies, but introduce substantial leverage over the current state-of-the-art. The aims can be summarized in four items:

- Optimized tamping
- Optimized grinding and milling
- Optimized lubrication and friction management
- Intelligent repair of track components

‘Optimized’ must here be understood as defining demands and thresholds in a holistic sense. The aim is to optimize LCC and RAMS performance of the entire track and the operating vehicles. In the same manner ‘Intelligent’ must consider local conditions: For example modularized solutions that can be adopted in a very short time will be required in some areas even if they are more expensive. Also in this case the global LCC and RAMS performance will guide the selection.

#### *Optimised condition monitoring*

In order to enforce the future increase in demands on efficient maintenance it is vital to detect track deterioration as early and accurately as possible. To this end, inspection, monitoring and detection procedures need to be substantially enhanced compared to the current state-of-the-art.

Condition monitoring is one part in an integrated asset management system that also includes prediction of subsequent deterioration and planning of maintenance actions and investments based on these prognoses.

Compared with the current state-of-the-art, the monitoring systems need to output data that are more relevant and better harmonized with numerical simulations of further degradation. Further, they should better relate to the current condition of the track and must provide a minimum of traffic disruptions. The development will set out from developments in recent years (see e.g. INNTRACK, D-RAIL, Capacity4Rail and other EC funded projects). Monitoring should here consider key performance issues of the entire track. This includes rail friction, rail crack detection (also cracks not located in the rail head), broken fasteners and deteriorated rail pads, cracked sleepers, fouled ballast, improper track stiffness, wrong stress-free rail temperature etc.

#### *Interaction with train fleet*

An important question for the railways is a functioning train–track i.e. wheel–rail interaction. In this question TD3.3 and TD3.4 will interact closely with both IP1 and IP5. There are two sides of the question namely:

1. Establish well defined and physically transparent and justified demands on vehicle characteristics. Here a multilevel approach will be employed with the first limit(s) relating to



track deterioration levels and can be enforced by differential track access charges. The second level relates to safety risks where a vehicle needs to be mitigated urgently. The costs of imprecise demands are very high, especially when it comes to the safety related limits.

2. Better handling of different damage phenomena to decrease costs and increase robustness. This is preferably handled preventively by ensuring suitable operating conditions and enable swift and accurate emergency actions. Also a full and correct understanding of the phenomena is crucial.

#### *LCC and RAMS performance*

As mentioned, LCC and RAMS will, together with technical capabilities and environmental impact, be the main evaluation criteria for the developed solutions. This in order to assure that there will be a market demand (and a business case) for the developed solutions.

#### *Environmental impact and sustainability*

The overall target in this TD is to minimize the environmental footprint and provide more sustainable track solutions. This will be addressed in the design of the demonstrators and be included as one of the evaluation criteria of proposed solutions. Further, some of the investigated solutions will explicitly address the influence of climate change and how to tackle the consequences for track.

It can also be noted that railways generate significant amounts of waste during construction, maintenance and renewal actions. This waste needs to be managed (cost) efficiently and in an environmentally friendly manner. Preferably it should be recycled and re-used in the railway, a topic that has been discussed above.

#### *Product identification and link to asset management*

The railway is becoming exceedingly more complex. In order for an infrastructure manager to keep track on installed components and thereby facilitate asset management, track components need to be identifiable. Solutions for such identification will be considered in the project and the most promising solution(s) implemented in demonstrators. Note that one identification method must not necessarily fit all components (due to their differing deterioration etc). However, a system approach will be taken where this is balanced towards increased costs in adopting parallel systems.

To further facilitate asset management, the TD will prioritize solutions that fit in a module based construction and building process.

#### *Safety*

Last, but not least, it should be highlighted that safety is always the top priority for railways. Developed solutions will provide sustained or improved safety as compared to the current situation. However this needs to be done without losing passengers and transport volume to road.



The following table summarizes some examples of how this TD will progress the state-of-the-art and overcome today's limitations and difficulties:

State-of-the-art	Advance beyond state-of-the-art
Although highly developed, current track structures are subjected to continuous increases in loads and demands on operational reliability.	Optimised design and maintenance of track to allow for increased loading and reducing LCC and enhanced RAMS of the entire system.
Damage epidemics like squats and RCF occur and cause high costs and operational disturbances	With an enhanced understanding of RCF, squats and also wear, a significant extension of life is feasible. Predictive models to foresee potential complications including contrasting to measured operational data. Translation to operational procedures.
Methods to evaluate track status and degradation rates exist, but are too limited to fulfil future demands	Improved monitoring concepts including accurate knowledge on what to monitor/measure, how to measure, and how to interpret gathered data and translate these to maintenance / re-investment plans
The use of material derived from limited material resources is widespread, but becoming more and more unsustainable	Introduction of re-used/recycled materials into the design and construction process
Maintenance procedures are becoming more and more unsustainable as time in track decreases whereas maintenance demands increases.	Improved precision in which maintenance to carry out when. Enhanced maintenance methods.
Noise and vibration emissions are decreasing, but will require even further reductions	Innovative solutions to mitigate emission, transmission and uptake
The track system deteriorates severely in specific sections.	Knowledge on influencing parameters for the local deficiency, collection and analysis of relevant data, locally tuned solutions to mitigate the deficiencies
Asset management is handled through elaborate processes including significant hands-on manipulation and limited precision	Improved identification of relevant data, collection of these data, evaluation of health status and prediction of deterioration in an overall system

### Technical Limitations/Barriers

The following technical barriers and limitations are foreseen for the TD.

Nº	Technical barriers and limitations	Mitigation action proposed
1	An important risk is that the implementation process is slow. One of the causes is that changes must be carried out taking into account today's infrastructure situation in a system context.	Several approaches to mitigate this risk have been outlined in this description; the stepwise validation of solutions, the early identification of assessment actions etc.
2	Lack of potential solutions to be evaluated	This risk is deemed to be limited judging from the input already obtained and the strong involvement of industry and infrastructure managers.
3	Find relevant tracks for demonstrator activities.	This issue has already been raised during consortium discussions, and there is an agreement on placement strategies that will include relevant operational conditions.
4	Cooperation problems/non-delivering partners	A common cooperation framework is defined, with working methodology, and division of work tasks and responsibilities at sub-task level.

### References to existing EU funded research projects

Potential synergies can be found with the following EU-funded research projects:

Acronym (EC Reference)	Description of Project
<b>CAPACITY4RAIL</b> (GA 605650)	Research work on infrastructure, train dispatching and timetable planning and monitoring. Recommendations for Open-Source and Open-Interface for advanced railway monitoring applications
<b>D-RAIL</b> (GA 285162)	Cost efficient measures to reduce derailments (setting limit tolerances).
<b>INNOTRACK</b> (GA 31415)	Analysis of major track cost drivers to reduce maintenance costs for sub-structure, track, S&C including LCC and logistics aspects

#### **3.5.3.3. Specific Demonstration activities and contribution to ITDs/SPDs**

##### Vision

The new technologies and innovations developed by Shift2Rail will be showcased (e.g. assembled, tested, validated) in real (physical) and/or simulated operational conditions by means of SPDs.

System concepts that may be demonstrated in SPDs include:

- New system concepts for high speed/mainline traffic
- New system concepts for regional traffic



- New system concepts for freight traffic
- New system concepts for urban/suburban traffic

These concepts have to be further studied since it is not possible to do all within the available budget. Also if demonstrators are carried out jointly for S&C and Track (and perhaps also Bridges/Tunnels) costs can most likely be reduced.

The work will show how the four traffic situations: High Speed/Mainline, Regional, Freight, and Urban/Suburban are targeted with the derived solutions. The current idea is that the work can validate optimum combinations of technology innovations and demonstrate the expected benefits of the innovations through identified KPIs.

The aim and direction of the demonstrations is to ensure safety, interoperability and competitiveness through the right selection of rail innovations the achievement of the three Shift2Rail targets related to capacity/user demand, reliability/quality of services and Life Cycle Costs/competitiveness.

#### **Interaction with other TDs**

TD3.3 will interact strongly with other TDs in IP3 (see Figure 66), and also with other IPs. In particular there is a tight integration with TD3.1, TD3.2, TD3.4 and the transversal action on noise and vibration. Further, work in TD3.3 on deterioration and maintenance needs relates strongly to TD3.6, TD3.7 and TD3.8 as discussed above. Transition zones are an area in common with TD3.5. Towards other IPs there is a very strong link towards IP1 and IP5, physically manifested in the wheel–rail interface. In addition there are indirect links towards IP2 and 4 in that solutions derived in TD3.3 will affect the boundary conditions for solutions derived in these IPs.



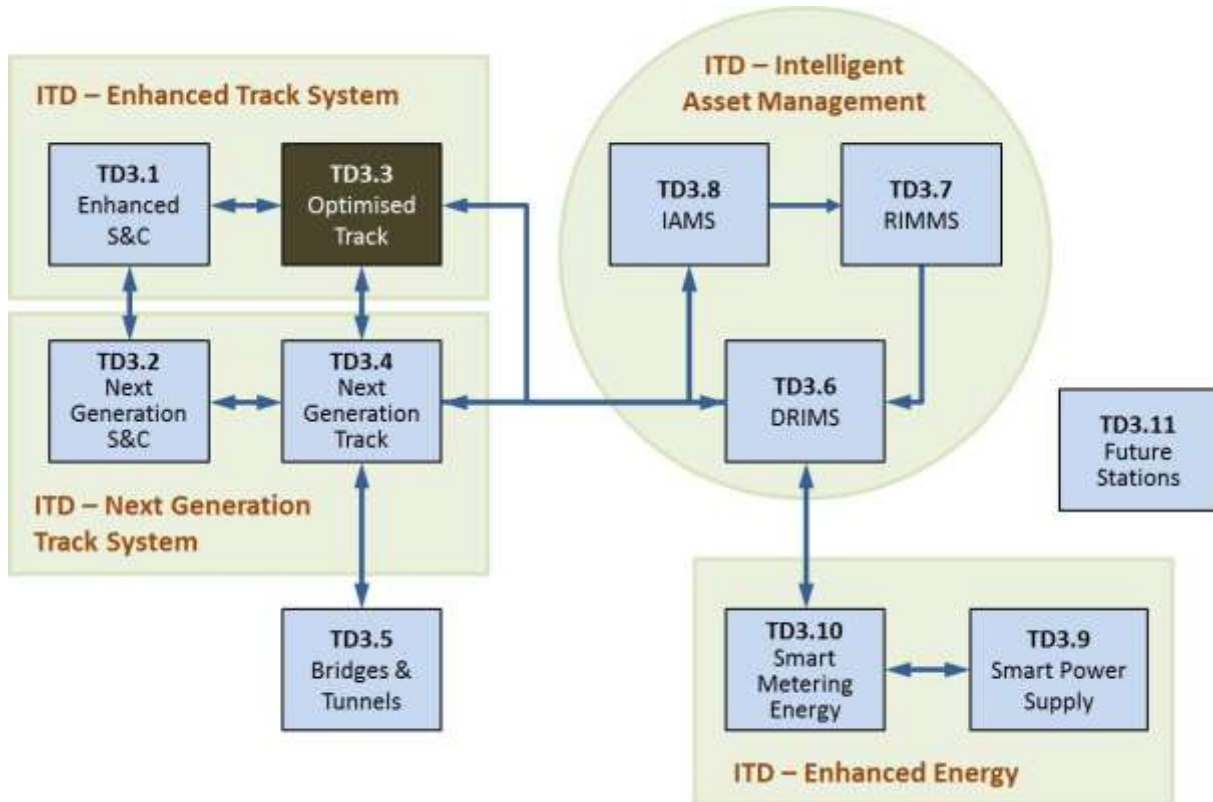







Figure 66: Relationship of TD3.3 with other TDs



### 3.5.3.4. Impact of the Optimised Track System

#### Technical impact

The following technical impacts are envisaged by the implementation of TD3.3 and TD3.4 and have been developed in the context of the three specific Shift2Rail global targets:





Impact type	Shift2Rail Impact	Contribution to KPIs (large spot=high contrib.)
<b>100% Capacity Increase</b>	Decreased track disturbances through less invasive construction, inspection, and maintenance procedures.	
	Reduction in failures/deterioration requiring service-affecting mitigation through more robust and reliable products, procedures and processes.	
	Decreased noise and vibration impact that will allow more traffic in affected line sections.	
<b>30% Reduction in LCC</b>	Extended operational life and decreased maintenance requirements through enhanced holistic track solutions	
	Harmonized assessment of solutions to a larger degree based on virtual testing that drastically reduces development costs and time-to-market.	
	Extended use of recycled material that reduces investment and disposal costs.	
	Decreased installation and replacement costs due to modular, and installation-friendly solutions.	
<b>50% Increase in Reliability &amp; Punctuality</b>	Pre-validation of solutions to reduce tune-in problems and provide predictable levels of robustness.	
	Reduction in unplanned maintenance through more robust track system solutions and increased use of predictive methods to plan optimal interventions.	
	Reductions in operational disturbances of inspections and maintenance through less invasive inspection methods and a shift towards plug-and-play constructions.	
	Optimized maintenance through intelligent monitoring and data analysis and prediction of deterioration rates	

#### Contribution to TSIs and standards

The results from TD3.3 will contribute to standards and guidelines. This will mean that the possibility of producing standards increases significantly.

### Strategic impact

From a strategic point of view, existing track technology is currently struggling to keep up with current increases in operational traffic, demands on reliability and LCC etc. At the same time the adoption of innovative new solutions is slow and limited. In this context, the current TD will provide an opportunity for large-scale validation of innovative solutions together with a quantification of their benefits. This is done in cooperation between infrastructure managers and industry, which improves the credibility significantly.

Impact type	Shift2Rail Impact	Contribution to KPIs (large spot=high contrib.)
<b>Support the competitiveness of the EU industry</b>	<ul style="list-style-type: none"> <li>• Global technological leadership supported by a combination of innovation and technical standards, setting an effective advantage for the European industry.               <ul style="list-style-type: none"> <li>○ An example of industry benefit is the development in close collaboration with infrastructure managers to ensure relevance in solutions</li> <li>○ Examples of infrastructure manager benefit are (modular and compatible) solutions targeting identified high-priority issues that are validated from a technical, LCC and RAMS-perspective</li> </ul> </li> </ul>	
	<ul style="list-style-type: none"> <li>• Increased attractiveness for end users through:               <ul style="list-style-type: none"> <li>○ Increase in operational reliability through decreased failure rates and maintenance needs</li> <li>○ reduced costs for rail transports</li> <li>○ Increased capacity</li> </ul> </li> </ul>	
	<ul style="list-style-type: none"> <li>• Establishment of a streamlined, well defined and largely virtualised validation processes that allows for a fast track towards implementation and world-wide marketing</li> </ul>	
	<ul style="list-style-type: none"> <li>• Promotion of modal shift through more reliable and affordable rail travels.</li> <li>• Increased societal safety by a modal shift from road where tens of thousands of Europeans are killed every year to rail, which is of an order of 50–100 times safer.</li> <li>• Greening of transport through the modal shift, but also through new more environmental friendly constructions.</li> <li>• Achieve single European Rail Area (SERA) through modularisation, standardisation, and a harmonised assessment methodology for innovative solutions.</li> <li>• Facilitating interoperability by higher capacity, and more reliable rail operations that enhances the logistic reliability in cross-modal transports.</li> <li>• Simplified business processes harmonised assessment methodology for innovative solutions.</li> </ul>	
<b>Degree of maturity of the envisaged solutions</b>	Dependent on specific solutions in the tested demonstrators they are envisaged to have a TRL of 5 to 7.	





### **Other impacts**

Maintenance costs for railway infrastructure amount to about 50–60% of total maintenance costs of the track. In addition, track related installation costs are a significant portion of total installation costs.

Furthermore, direct, secondary and long-term costs related to malfunctioning track structures are massive. For this reason, the societal impact of the proposed project is very large.

The reduction of traffic disturbance related to maintenance will also bring about an important impact. Large track works often involves shutting down traffic for a considerable amount of time. Improved solutions that require less maintenance, improved precision in identifying exact maintenance targets, and improved installation methods will decrease this significantly.

For the industry, the project will translate into the development of new innovative technologies for premium track structures. The benefits from these improved technical solutions imply increased profits at the same time as lower costs for customers. Note that an important part in this is the possibility to quantify, validate and account for the life-cycle-cost savings and environmental benefits that are the result of the improved technical solutions. This will give the industry (and the entire railway sector) the possibility to focus on total cost savings without the (currently too common) fixation on installation costs that tend to promote cheap, low-quality solutions that become more costly in a life-cycle perspective.

### ***3.5.3.5. Implementation of the work programme***

#### **Overall approach and methodology**

The TD process follows a tightly integrated chain (with feedback) starting from the initial identification of future needs of the railway and potential solutions to meet these needs. These identified solutions are investigated in terms of technical capability, environmental footprint and LCC/RAMS performance. It should be stressed that such an investigation will require increased knowledge in several areas such as the influence of material characteristics, characteristics and influencing factors behind different damage phenomena etc. The most promising solutions will be selected and clustered into a number of demonstrators in order to maximize benefit. Depending on the level of complexity needed to validate functional claims, these may be scaled demonstrators, demonstrators on dedicated test tracks, or demonstrators on operational track. The demonstrators will be produced and put into operation. The performance will be monitored over time, and predictions of performance will be updated subsequently. Finally, conclusions on the impact of the demonstrated solutions will be made and the solutions prepared for market. It should be noted that the development includes a tight integration with numerical simulations and predictions to minimize costs and risks at the demonstrator stage.

The methodology sets out from two facts: Firstly, the current European railway is a patchwork of technologies and components that together represent an enormous investment. Secondly, the room for trial-and-error is very small. Thus, in order for innovative solutions to gain a foothold they must, at least in the short and medium term, play well with existing solutions. In addition, they must provide a significant and validated benefit. If not, infrastructure managers will 'play it safe' and stick to existing and tried (but perhaps not optimal) solutions.



To this end, all solutions proposed in the TD will be scrutinised before even being allowed to be included in a demonstrator. In addition, both the development of solutions and the quantification of benefits provided by the solutions will be supported. Numerical simulations to understand technological features and able to investigate a broad range of operational scenarios will be employed here together with LCC/RAMS analyses to quantify the benefit of the solutions.

This validation will be carried out in a structured scheme that features an increased level of detail (and also complexity and costs).

- In the first stage an initial screening will be performed to ensure that the proposal is technically feasible, targets an identified need and is likely to be economically sound.
- In the second stage the feasibility will be further ensured by '**scaled tests**'. This may imply actual scaled, physical tests, but also limited numerical simulations, limited data analyses etc.
- If required, a third stage will contain '**off-line tests**'. This implies tests that feature actual track components and/or structures, but do not involve (or disturb) operations. Examples may be component testing on a test track, full-scale simulations with collected (or synthetic) operational data, or off-line analyses of large volumes of data
- The final stage will be the actual implementation in '**operational tests**'. This may imply installation of a component in track, on-line analysis of conditioning data, full-scale implementation of repair techniques etc. At this stage the solutions should be validated to such a degree that feasibility (and also safety and economic viability) is assured.

Note that an important part of Shift2Rail is to derive this innovation assessment framework.

Moreover, additional means will be employed to ensure that the solutions will be validated. As an example, statistical methodologies will be employed to ensure that the data acquisition phase of the project provides data structures that are scoped correctly to provide information that enables benchmarking towards existing track forms. Established cost benefit analyses previously undertaken by other EU member states that have been surveyed by ERA will be consulted and used as a reference point for benchmarking. Particular emphasis will be placed on safety, sustainability and environmental issues with the objective of ensuring that a holistic strategy to minimize environmental footprint, whole life energy consumption and societal hazards.

### **Workplan description**

The workplan description below is structured around the process of assessing, developing and evaluating innovative track solutions. This also includes deriving improved methods for assessment in areas where such knowledge is lacking.

Figure 67: Workplan of TD 3.3

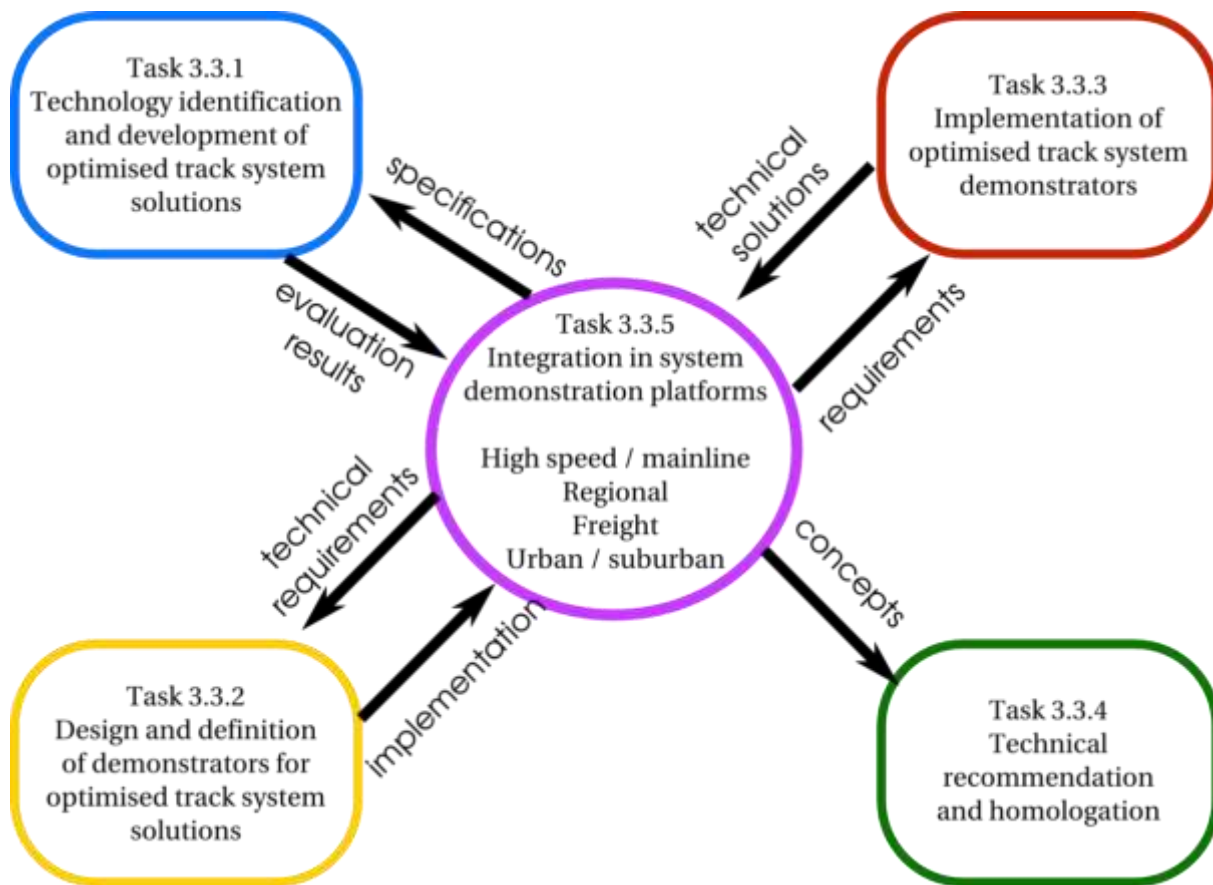

**High Level Task Breakdown**

Task	Task Name	Task Description	Lighthouse Project Contribution (%/ Budget)
Task 3.3.1	<b>Demonstrator overview plan and design of optimised track system solutions</b>	<ul style="list-style-type: none"> <li>Detailing of a specified plan for the work in this TD in close cooperation with other TDs.</li> </ul>	N/A
Task 3.3.2	<b>Technology identification and development of optimised track system solutions</b>	<ul style="list-style-type: none"> <li>Identify and evaluate solutions for optimized track components and systems. The compiled results will be a recommendation of suitable track solutions to incorporate in subsequent development and testing in later tasks, This identification sets out from the needs and potential solutions identified. To obtain a manageable scope, the task is divided in subtasks related to rail, fastening/pad, sleeper, and support solutions. The pertinent subtasks will interact closely.</li> <li>In addition stand-alone solutions targeted at noise/vibration, operational and maintenance issues, and optimised condition monitoring are also identified.</li> <li>For each solution, improvement beyond current state-of-the-art and fulfilment of future demands will be evaluated and quantified for subsequent prioritisation.</li> <li>A (sub)system assessment is employed to analyse how the solutions are performing in current and future railway systems. This includes investigations on how the solutions are influenced by, and interacting with operational traffic.</li> <li>The most promising solutions will be selected and subjected to an overview LCC/RAMS and (when needed) FMEA analyses to make a first validation of their potential.</li> </ul>	In2Rail

Task	Task Name	Task Description	Lighthouse Project Contribution (%/ Budget)
Task 3.3.3	<b>Design and definition of demonstrators for optimised track system solutions</b>	<ul style="list-style-type: none"> <li>• Create a detailed design of the demonstrators for optimised track system solutions from most promising solutions derived in the previous task.</li> <li>• Cluster these classified solutions into a number of demonstrators. This will maximize the number of solutions that can be tested and minimize costs for these tests. Further, the needed scale and traffic types of the demonstrator will be identified: If a scaled test is sufficient to demonstrate a certain capability and cheaper than a full-scale test, then a scaled test will be used.</li> <li>• Designs of the demonstrators (including incorporated solutions) will be specified. This includes required evaluations to obtain permissions to test (assessment in the case of operational tests). It also includes an evaluation of the expected outcome of the tests to decide influencing test parameters and to be able to scrutinize demonstrator test results towards predicted outcomes.</li> <li>• The demonstrator tests will be specified in detail. This will include test plans regarding times, locations and responsibilities. It will also include suitable simulations of the demonstrator operations required for a first assessment of the solutions</li> </ul>	
Task 3.3.4	<b>Implementation of optimised track system demonstrators</b>	<ul style="list-style-type: none"> <li>• Testing of the demonstrators for optimised track system solutions.</li> <li>• Design, manufacture, assembly etc of the demonstrators, obtain required documentation and approval, test execution and pertinent data collection. It will also include comparison of actual results with tentative simulation results and validation of LCC and RAMS estimations.</li> </ul>	
Task 3.3.5	<b>Technical recommendation and assessment</b>	<ul style="list-style-type: none"> <li>• Finalize and document obtained and needed validation and assessment actions as a basis for final approval by European and National Safety Authorities.</li> <li>• Document how developed solutions will influence the current situation including proposed practices regarding maintenance, logistics etc.</li> </ul>	
Task 3.3.6	<b>Integration in system demonstration platforms</b>	<ul style="list-style-type: none"> <li>• The new technologies and innovations developed by Shift2Rail shall be showcased (e.g. assembled, tested, validated) in real (physical) and/or simulated operational conditions by means of SPDs.</li> </ul>	

**3.5.3.6. Planning and budget**

**TD3.3 Gantt Chart**

TD3.3 - NEXT OPTIMISED TRACK SYSTEM		2015				2016				2017				2018				2019				2020				2021				2022				2023				2024							
Task	Description	Q1	Q2	Q3	Q4	Q1	Q2	Q3	Q4	Q1	Q2	Q3	Q4	Q1	Q2	Q3	Q4	Q1	Q2	Q3	Q4	Q1	Q2	Q3	Q4	Q1	Q2	Q3	Q4	Q1	Q2	Q3	Q4	Q1	Q2	Q3	Q4	Q1	Q2	Q3	Q4				
3.3.1	Demonstrator overview plan and design of optimised track system solutions																																												
3.3.2	Technology identification and development of optimised track system solutions																																												
3.3.3	Design and definition of demonstrators for optimised track system solutions																																												
3.3.4	Implementation of optimised track system demonstrators																																												
3.3.5	Technical recommendation and homologation																																												
3.3.6	Integration in system demonstration platforms																																												

**TD3.3 Budget**

The estimated budget for the TD is around 18.7M€.

### 3.5.4. TD3.4 Next Generation Track System

#### 3.5.4.1. Concept and objectives of the Next Generation Track System

##### Context

TD3.4 'Next Generation Track System' will be using the same framework as TD3.3, 'Optimised Track System', to identify and evaluate solutions. However, the solutions derived in this TD target a time horizon of around 40 years beyond the present state-of-the-art. Therefore, harmonisation toward today's railway system is less important, whereas step changes in performance are highly prioritized. Thus, all present perceptions regarding design, maintenance, operations, etc. are revisited with a much more open frame of mind. The overarching aim is to provide the key railway functionality without being restricted to current practices for achieving this target. Solutions to be implemented in the demonstrators – in the form of products, processes, and procedures – will thus have a very forward-looking character. As in TD3.3 all solutions will be developed and verified with the aspect of interaction with vehicles. The influence of TD 3.3 on TD 3.4 is depicted in Figure 68.

**Figure 68: Influence of TD 3.3 on TD 3.4**

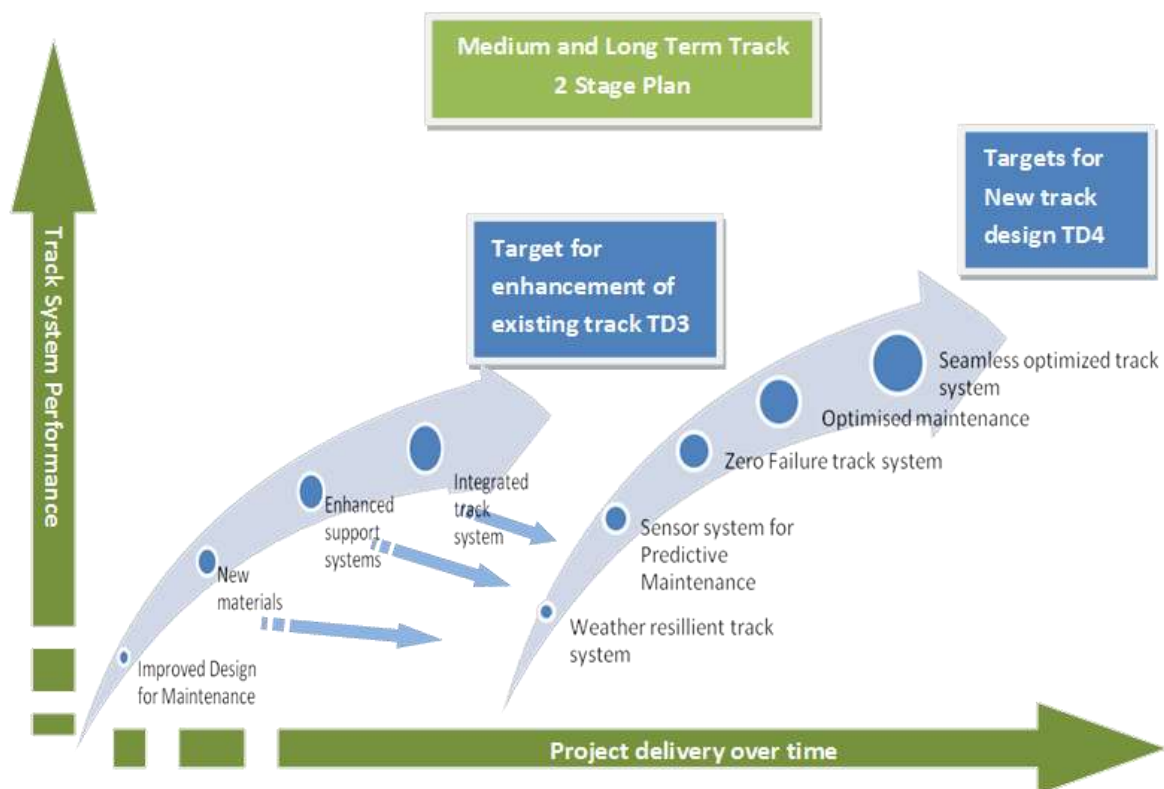

##### Definition and justification of objectives

The long-term objectives of this TD are

- Increase lifetime of track by 150%



- Decrease traffic disturbance due to track maintenance and faults by 75%
- Develop and deploy seamlessly integrated tools to allow for infrastructure managers to evaluate track solutions from a technical, economic, environmental and operational perspective including LCC and RAMS evaluations
- Extend these tools to provide the infrastructure manager with means to optimize a pro-active management plan from a system perspective

The latter two items relate to a substantially improved precision in decisions regarding track design and investments, and in the urgent need to move further into pro-active maintenance definition and planning.



The following table summarizes some **objectives** and related deliverables of this TD:

Objectives	Result	Deliverable
Radically improved rail damage prevention and mitigation	Innovative materials designs and processes	Significantly enhanced knowledge and predictive capabilities with real-time calibration
Exhaustive status monitoring integrated in asset management	Integrated monitoring, analysis and prediction.	Modular (autonomous) solutions to asset management systems
Decreased operational loads and deterioration	Optimized system-wide improvements	Guidelines and operational recommendations
Better resistance to climate changes	New track solutions	Optimize requirements and evaluated solutions
Solutions towards zero-maintenance tracks	Innovative materials, construction and logistics	Optimized products, processes and procedures
Current joining technologies are insufficient for future demands	Innovative joining technologies	Higher precision in requirements and objectives. Evaluated solutions
Rail support stiffness needs to be tuned to varying operational conditions	Solutions including non-traditional use of high-tech materials.	Guideline for suitable stiffness for different conditions. Evaluated operational solutions.
Constructions towards zero environmental footprint	New solutions for large-scale re-use of materials in track design and maintenance	Solutions evaluated in a comprehensive process
Optimized and monitored track support conditions that eliminates negative influence of e.g. transition zones and minimizes deterioration	Validated innovative solutions in construction, geophysical evaluation and data analysis	Significantly enhanced knowledge on how track support conditions influence deterioration characteristics and resulting products, processes and procedures.
Create a rail system with a minimum of deterioration due to interaction with train fleet	An optimised rail system due to deterioration of interaction with train fleet	Specifications with precise figures to the manufacturers of vehicles
Increased knowledge of current health status of the track	Seamless integration of health monitoring in the track structure coupled to prediction of deterioration rates and integrated in an asset management system	Improved monitoring strategies and capabilities; significantly enhanced predictive capabilities with structured output
Elimination of unacceptable noise and vibration levels	Solutions to reduce generation, transmission and impact, including optimized framework of allowed levels.	Enhanced solutions based on increased knowledge and evaluated solutions that better can meet future higher demands

### **Alignment with Shift2Rail Strategic Master Plan**

The specific benefits will have a major impact in the Shift<sup>2</sup>Rail objectives. The strategic outcomes of TD3.4 are foreseen as:

- Increased capacity



- Reduced life-cycle cost
- Reduces investment cost
- Increased sustainability
- Improved attractiveness
- Enhanced customer experience
- Increased safety

Items below are in general a magnitude over improvements in TD3.3

Overall KPIs are

- Reduced overall LCC
- Increased track performance and decreased traffic disturbance
- Improved environmental performance

More specific track KPIs are

- Decreased occurrence/magnitude of wear and RCF on the running surface
- Increased geometry performance
- Improved stiffness characteristics including reduced stiffness deviations
- Decreased noise and vibration pollution
- Improved monitoring and validation procedures to enhance control over deterioration

Three important areas where societal benefits will be provided by this work on the overall system-level KPI's for the whole Shift2Rail initiative are

- Increases in capacity
- Improved operational reliability
- Increased competitiveness for industry and railway transport

#### ***3.5.4.2. Technical ambition of the Next Generation Track System***

##### **Ambition**

The work in this TD aims at a substantial leverage of the track system from the current state-of-the-art, and also from the developed medium-term solutions. To this end, the current status of track technology and suggested medium-term solutions will be scrutinized. Needs for further improvement is identified in areas presented below. The description follows the physical structure of the current track structure even though solutions are not limited to this structure. In addition lateral



areas, such as maintenance and combatting of noise emission that are partly included in the technical sections are also investigated in search for self-standing solutions. Consequently, the state-of-the-art and foreseen development in these areas are also given a separate section below. Note that the suggested improvements will not only set out from results in TD3.3, but also from previous and on-going European projects from which researchers involved in the TD have a deep experience.

The TD description is based on in-depth discussions with infrastructure managers in Europe to identify common problem areas and needs for development. To this end, the 'customer requirements' are established. Conversely, there is a need for flexibility not to block future suggestions for innovative solutions that arise in the consortium, or as a result from open calls etc. To this end, the workplan is organised as a scheme to evaluate innovative solutions. Some of these innovative solutions are described in the following, whereas other will emerge as the project commences.

The solutions derived in this TD will be evaluated based on LCC and RAMS performance. To this end, LCC and RAMS-analysis procedures developed in INNOTRACK will be further refined and employed.

The solutions are not generally confined to the current structure of rails, fastenings, sleepers and track foundation, but instead focus on providing the basic demands:

- Running surface that provides low running resistance, maintains gauge, provides steering, has very low deterioration
- Support for the running surface that keeps it fixed in vertical, lateral and rotational direction that also provides sufficient stiffness.
- Track foundation that provides a sufficient and continuous stiffness in the lateral and vertical direction including smooth transition to bridges.
- Monitoring practices that provide real-time access to relevant track data (including a specification of what 'relevant' means) at low cost.
- Maintenance practices that introduce correct actions at the correct time with a minimum of intrusion in the track system (including a specification of what 'correct' means).
- Eliminate noise and vibration pollution to the surrounding environment and to rail passengers.

In addition, consideration will be given to the logistics and the focus on providing standardized and modularized track components with a limited complexity.

Examples of such overall solutions include integrated track designs where the aim is to define requirements for the design of an integrated (power, signalling, communications, monitoring) infrastructure for freight, regional or urban/suburban, and high-speed tracks. Among the technical requirements that need to be considered are speeds and loads including their evolution over the track life cycle.



### **Track technology progress beyond State-of-the-Art and medium term solutions**

The development of demonstrators will begin from identified long-term demands on the track structure. These demands incorporate expectations on future operational loads, maintenance possibilities, LCC and RAMS levels, climate impact etc.

To derive long-term solutions, the main functions of the rail system will be reviewed. Main functions of an ideal track will be detailed (e.g. zero maintenance, zero climate impact, 100% availability, zero accidents, low costs etc.). The suggested solutions will provide a goal fulfilment that significantly exceeds current and medium term solutions including solutions from parallel projects such as Capacity4Rail.

#### *Running surface solutions*

The target is to provide a running surface that provides optimal conditions for train operations. Examples of solutions that will be investigated include:

- Identification and management of key functions and operational parameters of the running surface
- Optimized running surface damage prevention and mitigation,
- Detailed measurement of running surface condition,
- Radically enhanced capabilities to adapt to climate change including short-term extreme-weather, temperature variations. Note that climate impact generally interacts with other factors. One example in the case of lateral track stability is braking practices, which includes the use of eddy current brakes,
- Innovative manufacturing and assembly technologies including modification and tuning to account for significant altered technologies and material selections,
- Optimized management of friction, running surface geometry, material selection with a zero maintenance aim, and
- High-precision and very detailed geometry and stiffness measurements and the adoption of these in a zero maintenance vision/self-adjustment.

These solutions also demand radically increased knowledge on how different material and interfacial characteristics relate to rail damage, what operational consequences of altered conditions are etc. There is also a very strong link to damage in switches and crossings (TD3.1 and TD3.2) that will be employed to obtain synergy effects.

#### *Solutions to provide proper support for the running surface*

The key function considered will be to keep the running surface fixed in the vertical, lateral and rotational directions while providing sufficient stiffness and damping. To derive drastically new solutions in this area and especially solutions that are optimal for various conditions will require a quantum leap in the understanding of how the technical characteristics of different solutions influence deterioration and life cycle costs.



Solutions to be considered may include:

- Optimal use of existing and innovative materials to optimise rail support.
- Re-use and recycling materials in fastenings and pads. Specifically, an analysis of the influence of these new materials in the reduction of noise and vibrations.
- New materials (re-use, recycling materials) in the design of rail supports.
- New design for the reduction of loads and increased durability. This includes integration of elastomeric elements to vibration mitigation, decreasing variations in track stiffness especially in transition zones, and increase of lifetime of rail support and track foundation.
- Improved designs to account for different operational demands.
- Fully integrated health monitoring systems regarding the entire track structure.
- Solutions to drastically improve track capacity and decrease maintenance demands.
- Intelligent integration of attenuation components including active solutions.
- Integration of ducts for communication, signalling, power supply, maintenance (e.g. optical fibre for track condition monitoring).
- New assembly-disassembly systems (plug & play, different connectors).

#### *Track support solutions*

Innovations in the design of supporting layers, substructure and superstructure will be required to develop an integrated design, construction and maintenance process for the track support structure. This process will need to account for the soil type available, proposing for example soil stabilisation treatments for each single situation and showing the optimized dimensions of the support layers into design charts, and support component integration. Potential solutions include:

- Harmonized classification of existing natural soil and improvements of existing natural soil characteristics (such as bearing capacity or permeability) by the addition of new or existing materials including construction and demolition waste.
- Engineering of supporting layers with improved soil by the addition of new/existing materials (bituminous, cementations). This includes cross sections and transition zone engineering.
- Improved analysis of required bearing capacities and settlement limits required by new track design and soil characteristics.
- Engineering of support components and their integration in existing and new track. This includes optimised drainage systems that can adapt to altered climate conditions.
- Improved new materials and combinations.
- Optimized innovative maintenance processes for remaining maintenance processes.



- Eradication of zones with ‘track memory’, which is manifested in the fact that track geometry faults tend to occur rapidly after mitigation. For a successful mitigation strategy there is a need to understand the underlying causes, monitor the relevant identified root causes and intervene with effective actions.
- Improved and more maintenance free drainage system.

### **Progress in related topics beyond State-of-the-Art and medium-term solutions**

#### *Noise and vibration mitigation and prevention solutions*

The research and development will concern new high performance noise and vibration isolation systems. This includes the development of innovative environmental components that, in optimal combinations can develop different levels of attenuation, particularly ground vibration and airborne noise (cf Recytrack – Life Programme, Rivas – FP7).

Solutions to be considered in the reduction of noise include:

- Improved methods for combined assessments of noise and vibration including solutions to derive toolboxes for an evaluation of the combined effect/cost of a range of different solutions to reach a target limit will be evaluated. The influence of renewed noise/vibration assessments, as a result of changes in legislation will be assessed.
- High-performance noise and vibration mitigation and prevention solutions. This will incorporate integration of solutions at the design stage, but also individual solutions such as acoustic barriers, new materials to increase efficiency, durability and allow easy installation and low maintenance.
- Development of innovative methods for reducing the generation and growth of roughness and corrugation.
- Specific effort to model and mitigate curve squeal, especially for light rail.

#### *Integrated maintenance procedures*

Maintenance is focused on the track structure. The solutions will provide:

- Optimized methods to provide suitable track geometry
- Optimized methods to provide suitable running surface geometry
- Optimized methods to provide suitable friction between running surfaces
- Innovative intelligent maintenance activities to mitigate the replacement of track components

The solutions must provide minimum disruption in traffic, be very LCC efficient and in principle provide a reset of operational conditions to as-installed. This relates to improvements in: evaluation of needs for maintenance, decisions on required maintenance actions, methods and efficiency of required maintenance actions, and coordination of maintenance actions. TD3.4 will interact strongly with TD3.6, TD3.7 and TD3.8. TD3.4 will define key operational parameters to measure and analyse, derive models to predict deterioration, establish technical limits for acceptable deterioration levels,



evaluate technical feasibility of improved maintenance procedures, and make consequence analyses of different maintenance scenarios. In contrast, the focus in TD3.6, TD3.7 and TD3.8 is overall data management, prioritisation and planning of maintenance actions.

#### *Optimised condition monitoring*

Technologies for early, high-precision track deterioration will be required in the long-term rail structures. Further, the monitoring actions should provide real-time input to high-precision predictions of subsequent deterioration and provide real-time categorisation of the current condition of the track.

The derived condition monitoring solutions will be fully integrated into an asset management system that includes deterioration prediction, planning of maintenance actions and investment decisions.

The development will build on the medium term solutions in that they should provide a significant leverage over these. The development starts from the identification of key track performance indicators without requirements to relate to current track solutions. Monitoring solutions target e.g. running surface friction, crack detection, insufficient support of the running surface, improper track stiffness etc.

#### *Interaction with train fleet*

An important question for the railways is a functioning train–track i.e. wheel–rail interaction. In this question TD3.3 and TD3.4 will interact closely with both IP1 and IP5. There are also two sides of the question namely:

1. Clearly and well defined and physically transparent and justified demands is a natural demand on vehicle characteristics. The next step with input from TD3.3.
2. The different damage phenomena are taken into account so the robustness clearly better. The knowledge has clearly increased of understanding of the deterioration phenomena.

#### *LCC and RAMS performance*

LCC and RAMS alongside technical capabilities and environmental impact will be the main evaluation criteria for the developed solutions. The reason is to ensure that there will be a market demand (and a business case) for the developed solutions.

#### *Environmental impact and sustainability*

The overall target in this TD is to eradicate the environmental footprint and provide sustainable track solutions. The fulfilment of these objectives is included in the solutions evaluation criteria and also addressed in the design of the demonstrators.

There is also scope for self-standing solutions to address influences of climate change and assess the consequences for the track, and to assess re-use of waste generated by the railways.

#### *Product identification and link to asset management*

In the long-term perspective the solutions will have integrated product identification capabilities to provide plug-in solutions for asset management systems.

To further facilitate asset management, the TD will also prioritize solutions that can accommodate a module based construction and building process.

### Safety

Safety is, and will continue to be, the top priority of railways. Developed solutions will be provided with integral safety characteristics. However this needs to be achieved without losing passengers and transport volume to road. Such a scenario would constitute a sub-optimisation since road transport is some 50–100 times less safe. Consequently, a major increase in overall safety will also be obtained by the major improvement in attractiveness the developed solutions will give the rail system.

The following table summarizes some examples of how this TD will progress the state-of-the-art and overcome today's limitations and difficulties:

State-of-the-art	Advance beyond state-of-the-art
Although highly developed, current track structures are subjected to continuous increases in loads and demands on operational reliability.	Radically optimized design, and maintenance of track to allow for long-time increase in loading at lower LCC and with high RAMS of the entire system.
Damage epidemics occur regularly and cause high costs and operational disturbances.	Significantly enhanced knowledge on influencing parameters for rail. Predictive models to foresee potential complications integrated with analyses of measured operational data. Seamless translation to operational procedures.
Methods to evaluate track status and degradation rates exist, but are too crude to fulfil future demands	Seamlessly integrated monitoring concepts including accurate knowledge on what to monitor/measure, how to measure, and how to interpret gathered data and translate these – in real time – to maintenance/re-investment plans
The use of virgin material is widespread, but becoming more and more unsustainable	Large-scale introduction of re-used/recycled materials into the design and construction process
Maintenance procedures are becoming more and more unsustainable as time in track decreases whereas maintenance demands increases.	Improved precision in which maintenance to carry out when. Enhanced maintenance methods.
Noise and vibration emissions are decreasing, but will require even further reductions	Innovative solutions to substantially remove noise and vibration issues
The track system deteriorates severely in specific sections	Knowledge on influencing parameters for local deterioration, on-line collection, analysis and predictions using relevant data. Locally tuned solutions to mitigate the deficiencies
Asset management is handled through elaborate processes including significant hands-on manipulations and limited precision	High-precision identification and real-time collection of relevant data, evaluation of health status and real-time prediction of deterioration from an overall system perspective
Every year tens of thousands of Europeans are killed on roads as compared to much safer railways.	Provide a large-scale shift to rail transports for regional and long-distance transport through significantly decreased costs, improve reliability and performance through TD3.4 solutions.



### Market Uptake

Traditionally, exploitation and possible market uptake has been a very lengthy process in the railway sector. Through a structured development of these demonstrators and their follow-up through direct cooperation between industry and infrastructure managers this uptake time will be significantly reduced. In Task 3.2 the Railway Regulators will be informed and given the possibility of giving recommendations at an early stage and advice on how the approval process can be streamlined. Finally, in Task 3.4 the European and National Safety Authorities will form a basis for final acceptance of the solutions.

### Technical Limitations/Barriers

The following technical barriers and limitations are foreseen for the TD.

Nº	Technical barriers and limitations	Mitigation action proposed
1	An important risk is that the implementation process is slow. One of the causes is that changes must be carried out taking into account today's infrastructure situation in a system context.	Several approaches to mitigate this risk have been outlined in this description; the stepwise validation of solutions, the early identification of assessment actions etc.
2	Lack of potential solutions to be evaluated	This risk is deemed to be limited judging from the input already obtained and the strong involvement of industry and infrastructure managers.
3	Find relevant tracks for demonstrator activities.	This issue has already been raised during consortium discussions, and there is an agreement on placement strategies that will include relevant operational conditions.
4	Cooperation problems/non-delivering partners	A common cooperation framework is defined, with working methodology, and division of work tasks and responsibilities at sub-task level.

### References to existing EU funded research projects

Potential synergies can be found with the following EU-funded research projects:

Acronym (EC Reference)	Description of Project
<b>CAPACITY4RAIL</b> (GA 605650)	Research work on infrastructure, train dispatching and timetable planning and monitoring. Recommendations for Open-Source and Open-Interface for advanced railway monitoring applications
<b>D-RAIL</b> (GA 285162)	Cost efficient measures to reduce derailments (setting limit tolerances).
<b>INNTRACK</b> (GA 31415)	Analysis of major track cost drivers to reduce maintenance costs for sub-structure, track, S&C including LCC and logistics aspects



### **3.5.4.3. Specific Demonstration activities and contribution to ITDs/SPDs**

#### **Vision**

This TD is dedicated to summarise the concept of SPD in Shift2Rail. The objective is that the new technologies and innovations developed by Shift2Rail will be showcased (e.g. assembled, tested, validated) in real (physical) and/or simulated operational conditions by means of System Platform Demonstrations (SPDs).

- Future system concepts for high speed/mainline traffic
- Future system concepts for regional traffic
- Future system concepts for freight traffic
- Future system concepts for urban/suburban traffic

These concepts have to be further studied since it is not possible to do all within the available budget. Also if demonstrators are carried out jointly for S&C and Track (and possibly bridges) costs can most likely be reduced.

The TD will show how the four traffic situations: High Speed/Mainline, Regional, Freight, and Urban/Suburban are targeted with the derived solutions. The idea today is that the work can validate optimum combinations of technology innovations and demonstrate the expected benefits of the innovations through identified KPIs. The aim and direction of the demonstrations is to ensure safety, interoperability and competitiveness through the right selection of rail innovations the achievement of the three Shift2Rail targets related to capacity/user demand, reliability/quality of services and life Cycle Costs/competitiveness.

#### **Interaction with other TDs**

TD3.4 will interact strongly with other TDs in IP3, and also with other IPs. In particular there is a tight integration with TD3.3, TD3.1 and TD3.2 and the transversal action on noise and vibration. Further, work in TD3.4 on deterioration, maintenance needs, etc. relates strongly to TD3.6, TD3.7 and TD3.8 as discussed above. Transition zones are an area in common with TD3.5. There is a very strong link towards IP1 and IP5, physically manifested in the wheel–rail interface. In addition there are indirect links towards IP2 and 4 in that solutions derived in TD3.4 will affect the boundary conditions for solutions derived in these IPs.



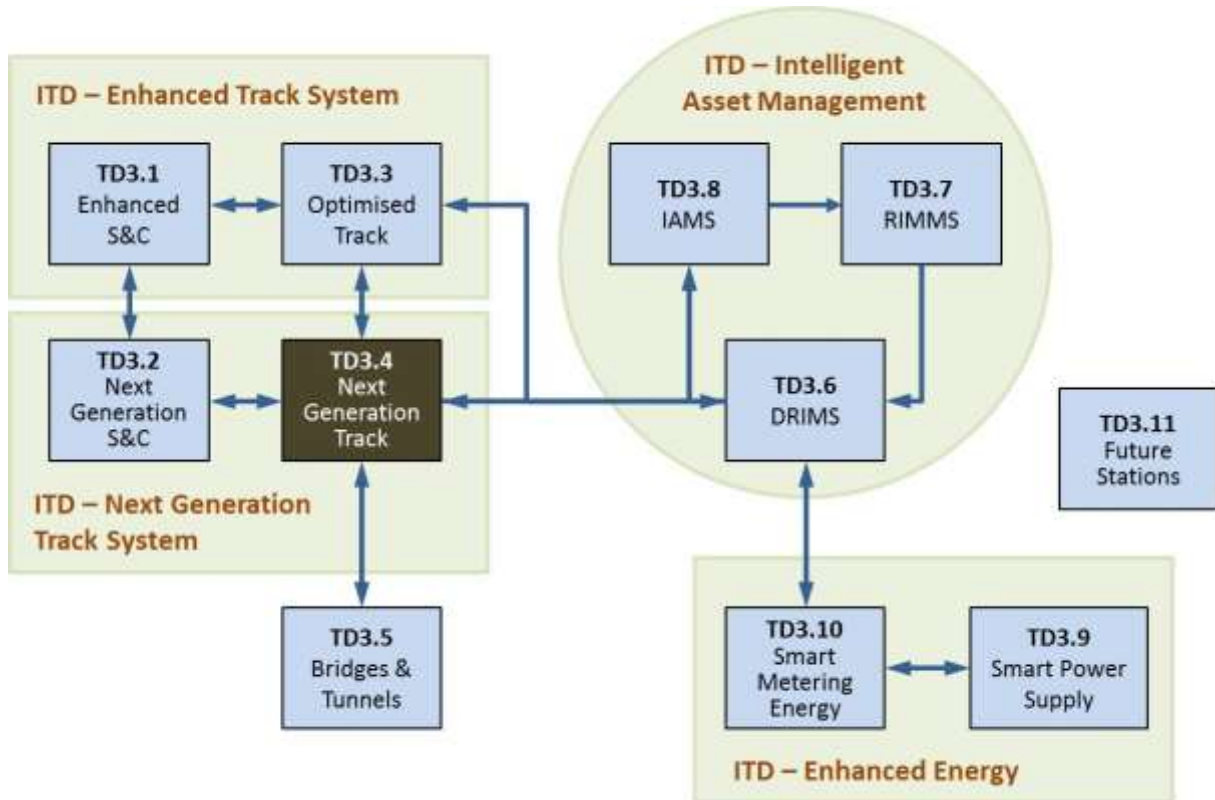







Figure 69: Relationship of TD3.4 with other TDs



### 3.5.4.4. Impact of the Next Generation Track System

#### Technical impact

The following technical impacts are envisaged by the implementation of TD3.4 and have been developed in the context of the three specific Shift2Rail global targets:





Impact type	Shift2Rail Impact	Contribution to KPIs (large spot=high contrib.)
<b>100% Capacity Increase</b>	Decreased track disturbances through less invasive construction, inspection, and maintenance procedures.	
	Reduction in failures/deterioration requiring service-affecting mitigation through more robust and reliable products, procedures and processes.	
	Decreased noise and vibration impact that will allow more traffic in affected line sections.	
<b>30% Reduction in LCC</b>	Extended operational life and decreased maintenance requirements through enhanced holistic track solutions	
	Harmonized assessment of solutions to a larger degree based on virtual testing that drastically reduces development costs and time-to-market.	
	Extended use of recycled material that reduces investment and disposal costs.	
	Decreased installation and replacement costs due to modular, and installation-friendly solutions.	
<b>50% Increase in Reliability &amp; Punctuality</b>	Pre-validation of solutions to reduce tune-in problems and provide predictable levels of robustness.	
	Reduction in unplanned maintenance through more robust track system solutions and increased use of predictive methods to plan optimal interventions.	
	Reductions in operational disturbances of inspections and maintenance through less invasive inspection methods and a shift towards plug-and-play constructions.	
	Optimized maintenance through intelligent monitoring and data analysis and prediction of deterioration rates	

#### Contribution to TSIs and standards

The results from TD3.4 will contribute to standards and guidelines. This will mean that the possibility of producing standards increases significantly.

### Strategic impact

From a strategic point of view, existing track technology is currently struggling to keep up with current increases in operational traffic, demands on reliability and LCC etc. At the same time the adoption of innovative new solutions is, as mentioned in section 1.3, slow and limited. In this context, the current TD will provide an opportunity for large-scale validation of **future** solutions together with a quantification of their benefits. This is done in cooperation between infrastructure managers and industry, which improves the credibility significantly.

Impact type	Shift2Rail Impact	Contribution to KPIs (large spot=high contrib.)
<b>Support the competitiveness of the EU industry</b>	<ul style="list-style-type: none"> <li>Global technological leadership through highly innovative solutions and technical standards.               <ul style="list-style-type: none"> <li>An example of industry benefit is the close interaction with end users in the development and validation of solutions, with a high degree of advanced virtual testing.</li> <li>Examples of infrastructure manager benefit are solutions towards zero maintenance and failure rates through tackling identified high-priority issues</li> </ul> </li> </ul>	
	<ul style="list-style-type: none"> <li>Increased attractiveness for end users through:               <ul style="list-style-type: none"> <li>very high operational reliability</li> <li>reduced costs for rail transports</li> <li>Increased capacity</li> </ul> </li> </ul>	
	<ul style="list-style-type: none"> <li>Employing a streamlined, well defined and highly virtualised validation processes that gives a smooth and efficient transition to implementation and world-wide marketing</li> </ul>	
	<ul style="list-style-type: none"> <li>Promotion of modal shift through highly reliable and efficient rail travels.</li> <li>Increased societal safety by a modal shift from road to rail, which remains of an order of 50–100 times safer.</li> <li>Greening of transport through modal shift, but also through close to environmental neutral constructions.</li> <li>Achieve single European Rail Area (SERA) through a very high degree of modularisation, standardised interfaces, and a harmonised assessment methodology for innovative solutions.</li> <li>Facilitating interoperability by very high capacity, and very reliable rail operations that enable close to seamless cross-modal transports.</li> <li>Simplified business processes through harmonised assessment methodology for innovative solutions.</li> </ul>	
<b>Degree of maturity of the envisaged solutions</b>	Very dependent on the specific solutions. The solutions tested in the demonstrators are envisaged to have a TRL of 7	



### **Other impacts**

Maintenance costs for railway infrastructure amount to about 50–60% of total maintenance costs of the track. In addition, track related installation costs are a significant portion of total installation costs. Furthermore, direct, secondary and long-term costs related to malfunctioning track structures are massive. For this reason, the societal impact of the proposed project is very large.

The reduction of traffic disturbance related to maintenance will also bring about an important impact. Large track works often involves shutting down traffic for a considerable amount of time. Improved solutions that require less maintenance, improved precision in identifying exact maintenance targets, and improved installation methods will decrease this significantly.

For the industry, the project will translate into the development of new innovative technologies for premium track structures. The improved technical solutions provided by TD3.4 will increase profits and at the same time lower costs for customers. Note that an important part in this is the possibility to quantify, validate and account for the life-cycle-cost savings and environmental benefits that are the result of the improved technical solutions. This will give the industry (and the entire railway sector) the possibility to focus on total cost savings without the (currently too common) fixation on installation costs that tend to promote cheap, low-quality solutions that become more costly in a life-cycle perspective.

### ***3.5.4.5. Implementation of the work programme***

#### **Overall approach and methodology**

The TD process follows a tightly integrated chain (with feedback) starting from an initial identification of long-term needs of the railway and potential solutions to meet these needs. The work will begin with an identification of potential track solutions starting from the set of main functions to be ensured and considering LCC/RAMS as well as FMEA as key parameters to be considered during the design process. Note that this investigation also requires increased knowledge in several areas beyond the current research front. The most promising solutions will be selected and clustered (in order to optimize testing/validation effort) into a number of demonstrators. Depending on the required level of complexity to validate functional claims, these may be scaled demonstrators, demonstrators on dedicated test tracks, or demonstrators in operational track. The demonstrators will be produced and put in operation. The performance will be monitored over time, and predictions of performance will be subsequently updated. Finally, conclusions on the impact of the demonstrated solutions will be made and the solutions prepared for market. It should be noted that the development includes a tight integration with numerical simulations to minimize costs and risks at the demonstrator stage.

The methodology sets out from two facts: Firstly, the current European railway is a patchwork of technologies and components that together represent an enormous investment. The room for trial-and-error is very small. Thus, in order for innovative solutions to gain a foothold they must, in the short and medium term, play well with existing solutions. However since the focus of this TD is on long-term solutions, this demand can be significantly relaxed. Instead focus is on providing a step-change in performance.



Secondly, the derived solutions must provide a significant and validated benefit. If this is not the case, infrastructure managers will also in the long-term rely on existing and moderately improved solutions. To this end, all solutions proposed in the TD will be scrutinised before even being allowed to be included in a demonstrator. In addition, both the development of solutions and the quantification of benefits provided by the solutions will be supported. Numerical simulations to understand technological features and be able to investigate a broad range of operational scenarios will be employed here together with LCC/RAMS analyses to quantify the benefit of the solutions.

This validation will be carried out in a structured scheme that features an increased level of detail (and also complexity and cost).

- In the first stage an initial screening will be performed to ensure that the proposal is technically feasible, targets an identified need and is likely to be economically sound.
- In the second stage the feasibility will be further ensured by '**scaled tests**'. This may imply actual scaled, physical tests, but also limited numerical simulations, limited data analyses etc.
- If required, a third stage will contain '**off-line tests**'. This implies tests that feature actual track structures, but do not involve (or disturb) operations. Examples may be component testing on a test track, full-scale simulations with collected (or synthetic) operational data, or off-line analyses of large volumes of data
- The final stage will be the actual implementation in '**operational tests**'. At this stage the solutions should be validated to such a degree that feasibility (and also safety and economic viability) is assured.

Note that an important part of Shift2Rail is to derive this innovation assessment framework.

Furthermore additional means will be employed to ensure that the solutions will be validated. As an example, statistical methodologies will be employed to ensure that the data acquisition phase of the project provides data structures that are scoped correctly to provide information that enables benchmarking towards existing track forms. Established cost benefit analysis previously undertaken by other EU member's states that have been surveyed by ERA will be consulted and used as a reference point for benchmarking. Further, particular emphasis will be placed on safety, sustainability and environmental issues with the objective of ensuring that a holistic strategy to minimize environmental footprint, whole life energy consumption and societal hazards.

### **Workplan description**

The workplan description below is structured around the process of assessing innovative track solutions. This assessment framework will then be employed to innovative solutions proposed within TD3.4, as described in the 'Technical ambition' section. The actual projects within Shift2Rail are thus likely to be organised around developing and evaluating these solutions. This also includes deriving improved methods for assessment in areas where such knowledge is lacking.

Figure 70: Workplan of TD 3.4

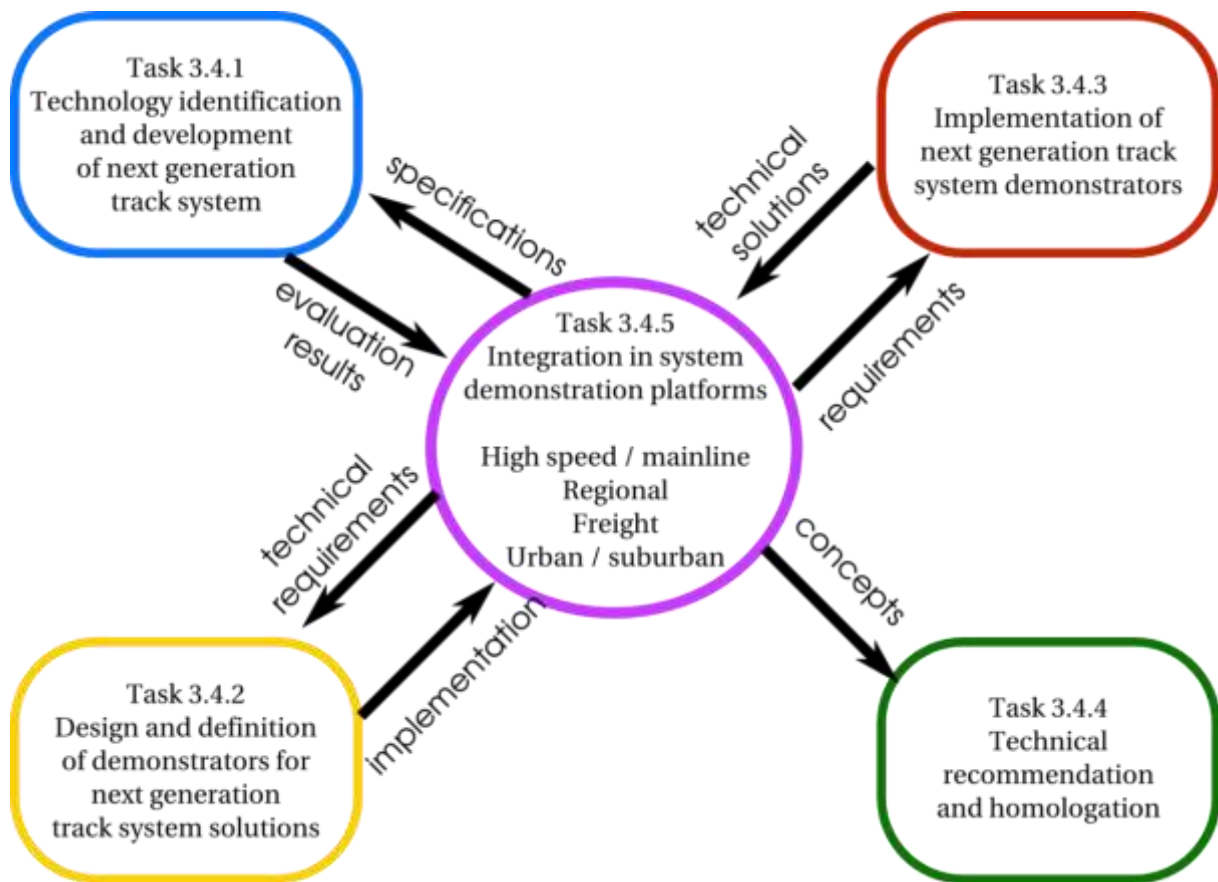



**High level Task breakdown**

Task	Task Name	Task Description	Lighthouse Project Contribution (%/ Budget)
Task 3.4.1	<b>Demonstration overview plan and design of next generation track system</b>	<ul style="list-style-type: none"> <li>Detailing of a specified plan for the work in this TD in close cooperation with other TDs.</li> </ul>	N/A
Task 3.4.2	<b>Technology identification &amp; development of next generation track system</b>	<ul style="list-style-type: none"> <li>Develop solutions for next generation track system, starting from the set of main functions to be ensured and considering LCC/RAMS as well as FMEA and robustness as key parameters to be considered in the design process. The compiled results will be a recommendation of suitable track solutions to incorporate in subsequent development and testing in subsequent tasks.</li> <li>In addition stand-alone solutions targeted at noise/vibration and maintenance issues are identified.</li> <li>For each solution, improvement beyond current state-of-the-art and fulfilment of future demands will be evaluated and quantified for subsequent prioritisation.</li> <li>A system assessment is employed to analyse how the solutions are performing in current and future railway systems. This includes investigations on how the solutions are influenced by, and interacting with operational traffic.</li> </ul>	In2Rail

Task	Task Name	Task Description	Lighthouse Project Contribution (%/ Budget)
Task 3.4.3	<b>Design and definition of demonstrators for next generation track system solutions</b>	<ul style="list-style-type: none"> <li>• Create a detailed design of the demonstrators for next generation track system solutions derived in the previous task.</li> <li>• Cluster these solutions classified into a number of demonstrators. This will maximize the number of solutions that can be tested and minimize costs. Further, the needed scale of the demonstrator will be identified: If a scaled test is sufficient to demonstrate a certain capability and cheaper than a full-scale test, then a scaled test will be used.</li> <li>• Designs of the demonstrators (including incorporated solutions) will be specified. This includes required evaluations to obtain permissions to test (assessment in the case of operational tests). It also includes an evaluation of the expected outcome of the tests to decide influencing test parameters and to be able to scrutinize demonstrator test results towards predicted outcomes.</li> <li>• The demonstrator tests will be specified in detail. This will include test plans regarding times, locations and responsibilities. It will also include suitable simulations of the demonstrator operations required for a first assessment of the solutions</li> </ul>	
Task 3.4.4	<b>Implementation of next generation track system demonstrators</b>	<ul style="list-style-type: none"> <li>• Testing of the demonstrators for next generation track system solutions.</li> <li>• Set-up of the demonstrators, obtain required documentation and approval, test execution and pertinent data collection. It will also include comparison of towards simulations and validation of LCC and RAMS estimations.</li> </ul>	
Task 3.4.5	<b>Technical recommendation and assessment</b>	<ul style="list-style-type: none"> <li>• Outline needed validation and assessment actions as a basis for future approval by European and National Safety Authorities and how current regulations may require modifications to support such a process.</li> <li>• Document how developed solutions will influence the current situation including proposed practices regarding maintenance, logistics etc.</li> </ul>	
Task 3.4.6	<b>Integration in system demonstration platforms</b>	<ul style="list-style-type: none"> <li>• This task is dedicated to summarise the concept of SPD in Shift2Rail. The objective is that the new technologies and innovations developed by Shift2Rail will be showcased (e.g. assembled, tested, validated) in real (physical) and/or simulated operational conditions by means of System Platform Demonstrations (SPDs)</li> </ul>	

**3.5.4.6. Planning and budget**

**TD3.4 Gantt Chart**

TD3.4 - NEXT GENERATION TRACK SYSTEM		2015				2016				2017				2018				2019				2020				2021				2022				2023				2024							
Task	Description	Q1	Q2	Q3	Q4	Q1	Q2	Q3	Q4	Q1	Q2	Q3	Q4	Q1	Q2	Q3	Q4	Q1	Q2	Q3	Q4	Q1	Q2	Q3	Q4	Q1	Q2	Q3	Q4	Q1	Q2	Q3	Q4	Q1	Q2	Q3	Q4	Q1	Q2	Q3	Q4				
3.4.1	Demonstrator overview plan and design of next generation track system solutions																																												
3.4.2	Technology identification and development of next generation track system solutions																																												
3.4.3	Design and definition of demonstrators for next generation track system solutions																																												
3.4.4	Implementation of next generation track system demonstrators																																												
3.4.5	Technical recommendation and homologation																																												
3.4.6	Integration in system demonstration platforms																																												

**TD3.4 Budget**

The estimated budget for the TD is around 14.50M €.



### 3.5.5. TD3.5 Proactive Bridge and Tunnel Assessment, Repair and Upgrade Demonstrator

#### ***3.5.5.1. Concept and objectives of the Proactive Bridge and Tunnel Assessment, Repair and Upgrade Demonstrator***

##### **Context**

As the European railway passenger and freight traffic continues to rise (passenger 34% and freight 40% in 2030 compared to a 2005 baseline), the access time to bridges and tunnels for inspection and repair is reducing. However, by performing fewer inspections or reducing the quality of the inspections, structures deteriorate at faster rates. This is due to delayed detection of damage, leading to more extensive time and cost consuming repairs in the long run. This becomes critical and severely impacts track availability due to extended track closures. With enhanced inspection methods and techniques, 50% reduction in inspection costs could be achieved whilst improving the quality of the inspection and rationalising the costs for corrective maintenance actions.

Even if many of the existing structures are close to or over the end of their service life, it is not economically feasible to envisage their replacement on a large scale since new standard bridges cost between 0.5-2M€ each. Similarly for the replacement of existing tunnels, apart from economic considerations, is not always a viable option due to the lack of space especially in densely populated areas. In view of this, the proactive and effective maintenance and upgrading of these structures to extend their service life is seen as a major priority to facilitate Europe's rail transport ambitions.

Today and likely in the future, the ideal upgrading option is administrative upgrading which means that tunnels and bridges are shown to be safe through calculations without any need for physical inspection. However, many of the existing structures were built to codes which did not take into account fatigue loading. The need for inspection and strengthening due to bigger traffic loads are increasing, whilst the ability to justify the pertinence of the calculations is becoming harder. As in other sectors, there is a need to use numerical simulation techniques that are closer to reality, coupled with physical inspection and maintenance data with the aim of better managing uncertainties and reinforce the administrative upgrading approaches and design of future structures.

The ability to rationalise and remove non-critical requirements from ageing codes and standards is a key requirement. This coupled with improved inspection and maintenance techniques will reduce the implementation of non-standard and expensive solutions within the rail industry, leading to the optimisation of the future structure design and operation.

To reduce future costs for tunnel and bridge maintenance it is essential that the experience from existing maintenance is considered when designing and constructing new tunnels and bridges.

It is viable to reduce structural noise and vibrations due to today's traffic and also to meet future increased rail traffic. With such systems, it is possible to reduce today's structural noise and vibration.

##### **Definition and justification of the objectives**

The main objective of TD3.5 is to improve the inspection methods and repair techniques for both reduction in costs and improving quality. With these methods and techniques a proactive and more

effective maintenance and upgrading of these structures to extend their service life is possible. Also a reduction of noise and vibrations related to these structures is also a prioritised objective. The objectives, expected results and deliverables are summarised in the table below:

Objectives	Results	Deliverables
Enhanced tunnel inspection, both regarding quality and effectiveness.	New and enhanced methods for inspection. Better inspection equipment. Improved repeatability and reproducibility.	Standards for new methods. Prototypes of new equipment
Enhanced bridge inspections, both regarding quality and effectiveness.	Automated and refined assessment methods. Improved repeatability and reproducibility.	Guidelines and case studies including demonstration of new methods.
Enhanced tunnel and bridge repair and upgrading methods with reduced time closure.	Repair methodologies with reduced need for access time including mechanisation techniques for the upgrading of tunnels and bridges without any need for track possession.	Guidelines and case studies with results from tests with new methodologies. Design concepts of new mechanised equipment for the improvement of tunnels.
Enhanced tunnel and bridge technology for Design, Construction and Maintenance.	Justified demands and requirements for tunnel and bridge design, construction and maintenance.	Suggestions for codes and standards together with case studies including use of new technologies.
Spread knowledge how new and enhanced technology for bridge and tunnels should be used.	Acceptance for new technology.	Case studies with application of new technologies and guidelines on how it can be used.
Reduce noise and vibration intensity related to structures.	Methods for noise and vibration reduction on structures.	Guidelines for design of noise and vibration reduction system for bridges and tunnels.

In more detail, the objectives are specified by five categories and the key aims of TD3.5 are:

- Develop new alternative inspection methods to allow faster and more accurate inspection of tunnels and bridges including improved repeatability and reproducibility;
- Develop new repairing, strengthening and upgrading methods which permit less traffic disturbance, fast installation with short track access time, and stepwise in nature to allow traffic movement between track operations;
- Develop noise and vibration damping methods suitable for structures;
- Suggest, based on maintenance experience, reductions of detailed requirements in codes and standards to maintain those essential for function, safety, desired durability in order for industry to facilitate, biddable tenders and transparent contracts; and
- Harmonise requirements in codes so uncertainties can be reduced and future new structures can be designed and constructed at reduced cost.



### **Alignment with Shift2Rail Strategic Master Plan**

The specific benefits of TD3.5 have a major impact in the Shift2Rail system-level KPIs as follows:

- Enhanced inspection and monitoring of Bridges and Tunnels facilitating proactive maintenance and giving increased capacity, reliability and reduced costs;
- Prolonged technical and economic use of structure giving less total disturbance, reduced costs and reduced environmental footprint;
- Improved codes and standards allowing for innovation in combination with biddable and transparent contracts will reduce investments costs and overall LCC;
- Reduction of noise and vibration levels comparable to -3 db;
- Improved capacity by reducing or eliminating existing restrictions; and
- Improved safety of track workers.

#### ***3.5.5.2. Technical ambition of the Proactive Bridge and Tunnel Assessment, Repair and Upgrade Demonstrator***

##### **Ambition**

Since the early days of railway, the status of bridges and tunnels have mainly been determined by visual inspections and to a small extent combined with some testing. The visual inspections have focussed on detection of damage on surfaces of visible parts. For tests, different approaches have been tried over the years. One common method, still in use, is to hammer on selected parts to listen for defects and look for deformations. This method is effective for finding defects in rock tunnels, however it is very time consuming. On riveted metallic bridges, hammering on rivets causes more deterioration problems by damaging paint work rather than detecting faults. The method is also used for other purposes, for example detecting concrete spalling. Non-destructive testing methods for bridges are becoming more refined and are able to find certain hidden defects. However, testing methods used today require long access to structures, long data evaluation times and in most cases complementary investigations. Justified recommendations on maintenance strategies are required for which methods to be used and what effective systems are used for monitoring deterioration over time. To meet the project objectives, the most commonly used inspections methodologies must be enhanced or replaced.

Image correlation techniques have developed rapidly in the last few years. Tools exist now for assembling stochastic captured data into single models. Pieces of data, photos and simple models can be combined to form a realistic model with embedded information. Such techniques are commonly used on the Internet to create models and knowledge systems based on seemingly random information. Today in the IT industry it is also common to describe data in form of a baseline and then only describe changes from such a baseline. For bridges and tunnels the same methodology is used, however it is very far from its full potential. Modern tools, which more or less automatically compile bridge and tunnel models, are not used. It follows then that inspection data cannot be added to such models and full advantage is not taken to their development over time.

In addition to enhanced inspections, solutions for strengthening and repair must be refined. Strengthening methods for bridges have been studied extensively for bending modes in ultimate limit state and several efficient methods exist. In the last 20 years, strengthening of concrete and metallic structures by use of Carbon Fibre Reinforced Plastic (CFRP) have through research become an effective and mature strengthening method well used for flexural strengthening in the ultimate limit state. Shear problems and buckling modes have also been addressed, however there are still questions to be solved to make the method accepted and to become widely used. The same methods can also be used for improving capacity to withstand loads in the service limit state, i.e. in particular, improving fatigue life. Recent research has shown very promising results on improvement of fatigue life and ductility. If only an increase in fatigue capacity is required, strengthening can be made more cost effectively using other methods. For the majority of structures ductility can be improved by strengthening, contrary to the results shown from many simplified laboratory tests when evaluated in the most common way. Reduction of noise and vibration emitted from structures is also considered upgrading and a variety of solutions exist. Compared to track and vehicle noise, the noise and vibrations from structures are lower in frequency and transfer differently into housing and the environment. The existing solutions need to be enhanced, verified and demonstrated. For strengthening of tunnels, staged methods with minimum disturbance to traffic must be developed. In addition, a concept, based on mechanisation, with whole tunnel improvement should be developed. The method should allow trains to run, and allow 24h work time, as traffic is protected from work zones. The improvement work will focus on the replacement of original lining with new concrete structure solutions. This type of mechanisation work could allow enlargement of tunnel sections in order to comply with larger gauges and safety requirement, such as TSI. New and improved methods should be implemented in technology demonstrators. The implementation itself and the outcome will be monitored. Demonstrators are to be evaluated using LCC and RAMS.

### **Market Uptake**

Market uptake of the developed technology will be ensured by the following means:

1. Demonstration will take place for technologies in a real operational environment to give acceptance and clearly show benefits.
2. The developed technologies will be superior to previous ones.
3. The solutions will be divided in orderly defined stages to be used stepwise or in blocks.
4. Suggestions will be proposed on improvement of codes and standards to allow more innovative solutions.
5. The solutions will be transparent and biddable.

The market situation for bridges and tunnels are by nature relatively incessant which facilitate easier market uptake. Suggested technologies will be used for a long period of time and industry will have the possibility of introducing parts incrementally.

Considering these facts, it can be forecast that in a period between 5 to 8 years after the end of Shift2Rail the new developments will be implemented in a high percentage of all tunnel and bridge projects (estimated in the range 40%-80% of projects in Europe).

### Technical Ambition TD3.5

The following table summarises how TD3.5 will progress the state-of-the-art and overcome today's limitations and difficulties:

State-of-the-art	Advance beyond State-of-the-art
Inspections of tunnels are today very time-consuming which includes long track closures. The inspections are quite subjective and will only find defects, i.e. measures can only be taken reactively to get rid of problems.	Inspections will be faster, partly automatic, and with enhanced quality. The inspections will be more objective, quantified and detect deterioration before defects arise and inspection results will have repeatability. With enhanced inspection, planning can be improved and actions can be planned well ahead to a lower cost with less traffic interruptions.
Inspections of bridges are subjective, costly and include disturbance of traffic. Inspection results are of varying quality and will only find defects, i.e. measures can only be taken reactively to get rid of problems	Inspections will be partly automatic and with enhanced quality. The inspections will be more objective, quantified and detect deterioration before defects arise. With enhanced inspection, planning can be improved and actions can be planned well ahead to a lower cost with less traffic interruptions.
Strengthening mostly covers improvement of ultimate limit state for semi static loading and is not fully working for a number of cases.	Strengthening methods can be used preventatively to reduce future problems. Strengthening methods will be enhanced on improving structural durability and ductility
Tunnels are repaired made on small degraded sections with a limited impact on the tunnel life span and do not typically allow a wider tunnel gauge.	Concepts for equipment for the mechanisation of tunnel improvement will be developed to undertake improvements of old tunnels and meanwhile allowing for traffic to continue operating.
Codes and standards are very prescriptive and reduce innovation and competition. Standards can also imply that best solution from life cycle analysis is not chosen.	Codes will be more descriptive, allow for innovation and for fair competition. Standards will promote best solutions from a life cycle analysis point of view.

### Technical Limitations/Barriers

The barriers to innovation in Shift2Rail include many themes and may be **[P]**olitical, **[Ec]**onomic, **[S]**ocietal, **[T]**echnological, **[L]**egislative, **[En]**vironmental in their nature. The bullet points below identify the barriers and obstacles which may limit the impact of TD 3.5 and reduce market uptake:

- Lack of investment in less profitable lines reduces uptake of innovative solutions **[P]**;
- Restrictions on operational data by confidentiality **[P]**;
- Restricted investment capital is a barrier to selecting optimised LCC option **[Ec]**;
- Resistance to change due to culture & competence through 'patterning' (forming of fixed ways of behaving) **[S]**;
- Current decision making sometimes based on subjectivity rather than actual data analysis **[S]**;
- European disparity in technological level **[T]**;and



- Regulatory barriers around introducing new products and techniques – i.e. national notified rules; national product acceptance processes; national standards; and specifications [L]

### **References to existing EU funded research projects**

Potential synergies can be found with the following FP6, FP7 and H2020 EU-funded research projects:

Acronym (EC Reference)	Description of Project
<b>NetTUN</b> (GA)	
<b>Sustainable Bridges</b>	
<b>MAINLINE</b> (GA 285121)	Life cycle assessment tool and findings regarding modern technologies for track, tunnels and bridges
<b>IN2RAIL</b> (GA 635900)	IN2RAIL is to set the foundations for a resilient, consistent, cost-efficient, high capacity European network by delivering important building blocks that unlock the innovation potential that exists in Shift2Rail
<b>PROFILE</b> (GA)	
<b>CAPACITY4RAIL</b> (GA 605650)	Research work on infrastructure, train dispatching and timetable planning and monitoring. Recommendations for Open-Source and Open-Interface for advanced railway monitoring applications
<b>INFRAVATION</b> (GA)	

### ***3.5.5.3. Specific Demonstration activities and contribution to ITDs/SPDs***

#### **Vision**

Some technology for bridges and tunnels can be demonstrated independently of other TDs and traffic situation which reduces risks and gives more reliable results. Demonstration will be made during development and are included in the tasks and will be performed by task members. When required or when demonstrators can be carried out jointly with other TDs, technology will be demonstrated as part of an ITD to reduce total costs and show benefits at a system level. To really uncover the potential in the next generation of railway systems, selected technologies from bridges and tunnels will be demonstrated at SPD level.

**Figure 71: Relationship of TD3.5 with other TDs**

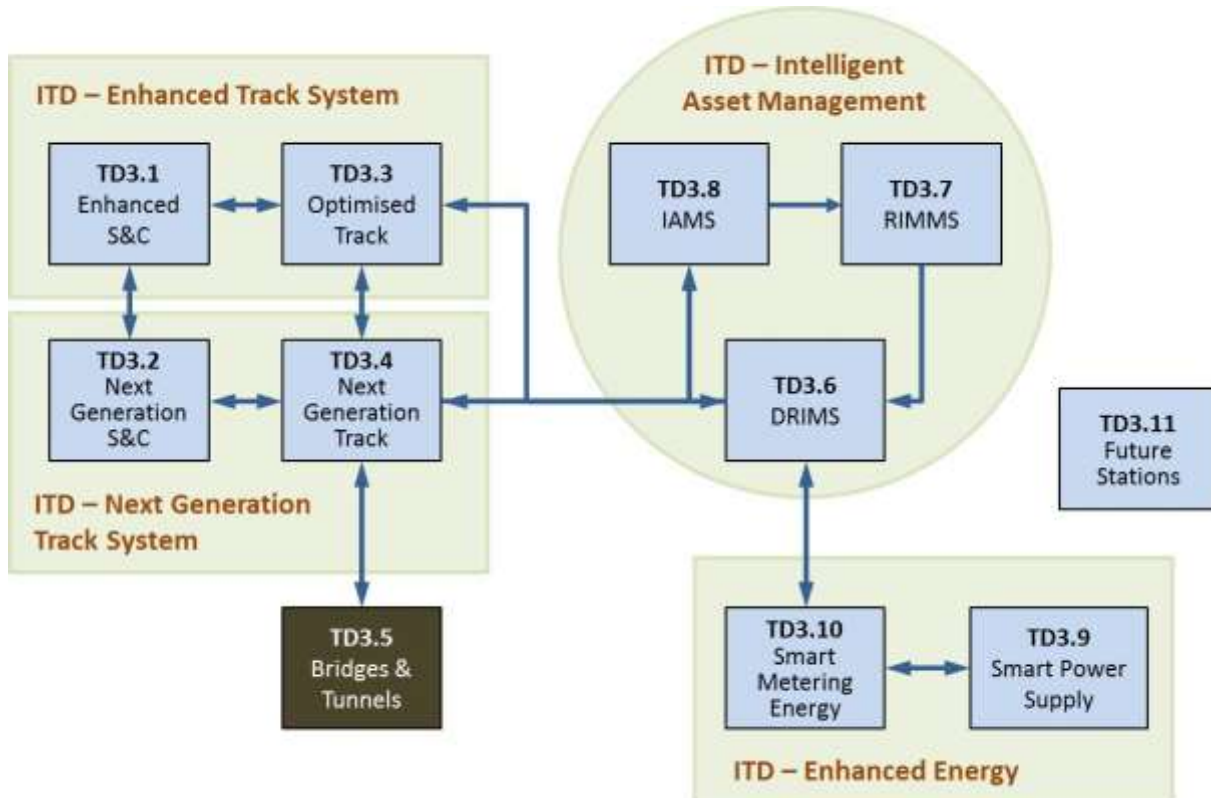

### **Approach**

With the large number of variety of bridges and tunnels, it is not possible to demonstrate all developed technologies in a single demonstrator. Different technologies need to be demonstrated in different structures. The tunnel inspection technology to be developed, tentatively the most promising for LCC and RAMS evaluation, will be demonstrated in a selection of tunnels in order to prove its feasibility for different tunnel types as well as for different stages of deterioration. The equivalent for bridge inspection technology will be demonstrated on a selection of bridges in a full operational environment.

As different bridges have different critical elements, the most promising inspection technology from LCC and RAMS evaluation will be demonstrated for the corresponding bridge type. Bridge monitoring and assessment technology will be demonstrated in a service limit state. Some technologies will also be demonstrated on real bridges taken out of service in the ultimate limit state when bridges are loaded to failure. These tests will also be used for demonstrating structural behaviour and uncertainties in existing models.

Systems for monitoring over time, filtration of data and storage of information in models will be demonstrated on virtual demonstrators either with real data from laboratory test or on fictitious data from real structures. Tunnel and bridge inspection technology is expected to reach up to TRL 7.

Evaluation of boundary conditions will be demonstrated by measurements in the service limit state on real structures. In the service limit state, for some structures it is possible that TRL 8 will be reached.



The repair of bridges will be demonstrated on real structures in an operational environment in the service limit state. This will include selected strengthening methods and methods to reduce noise from metallic bridges. The ultimate limit state demonstration will be made at scale test in a controlled laboratory environment. Bridge repair technology is expected to reach up to TRL 7.

The tunnel repair technology to be developed will be demonstrated by small scale testing, either in the laboratory or in a short section of real tunnels in an operational environment. Tunnel repair technology is expected to reach up to TRL 7. Concepts of mechanisation will reach a lower level.

The developed improvement technology for transition zones must be demonstrated in collaboration with TD3.3, TD3.4 and TD3.7. The improved transition zones is expected to reach up to TRL 5

The development of bridges and tunnels at system level must be demonstrated in cooperation with TD3.6, TD3.7 and 3.8. The extended use of the structure can be demonstrated virtually in order to clearly show savings in capacity, costs and reliability.

The outcome from the ITD can be used in an SPD, were the monitored and well maintained structures demonstrate that they allow for increased capacity and reliability or in unforeseen events will imply reductions in order to keep safety and comfort at desired level at the same time as updated information is given to users and traffic control.

All remaining results that are not demonstrated in a real operational environment will be demonstrated virtually in fictitious demonstrators.

#### ***3.5.5.4. Impact of the Proactive Bridge and Tunnel Assessment, Repair and Upgrade Demonstrator***

One of the basic ideas behind TD3.5 is that the findings will influence standards in two ways namely to standardise repair and strengthening methods of existing structures and to be input to enhance today's Eurocodes for new structures.

With the suggested technology, it is estimated that expensive tunnel and bridge inspections can be reduced by 50%, while improving safety and quality. This gives savings in the order of 30 M€ (30 000 000€) every year. In addition, further savings are made by reduced track closures caused by inspections. For tunnels, track closures for inspections are reduced by 50 %.









It is estimated that the remaining life of existing bridges will on average be extended by more than 10 years. Such an extension will make more effective use of existing structures and annually save in the order of 1.0 to 1.5 B€ (1 500 000 000€). With societal costs for traffic disruption of the same order as the building cost, potential savings are doubled. Prolonged use of existing structures as suggested will also reduce line closure time for bridge replacement by an average of 10 %.

Based on today's traffic situation, noise and vibration intensity can be reduced by up to 50 %.

New industrialised methods and refined codes and standards are estimated to have a potential of reducing costs for bridge construction by up to 40 % including societal costs. In addition, refined codes and standards with compatible safety can also reduce the cost for new tunnels.

### Technical impact

The following technical impacts are envisaged by the implementation of TD3.5 and have been developed in the context of the three specific Shift2Rail global targets:

Impact type	Shift2Rail Impact	Contribution to KPIs (large spot=high contrib.)
<b>100% Capacity Increase</b>	Decreased track disturbance through better inspection methods, better planned maintenance and prolonged life of existing structures.	
	Increased bearing capacity and bridge behaviour will allow for larger axle loads and higher speeds	
	Decreased noise and vibration impact that will allow more traffic in affected line sections	
<b>30% Reduction in LCC</b>	Extended life of existing structures	
	More refined codes on bridge dynamics allowing for less expensive special solutions on high speed lines	
	Demands and requirements in codes and standards allowing for innovation and fair competition	
	Proactive maintenance implying lower cost interventions before damages escalate	
	Enhanced inspection methods with higher degrees of automation	
<b>50% Increase in Reliability and Punctuality</b>	Reduction of unplanned maintenance and restrictions through enhanced inspection methods allowing for better planning.	









### Contribution to TSI/Standards

TD3.5 is expected to propose changes to existing TSIs or the generation of new TSI requirements and will actively target the closure of any relevant open points or issues taking into account the Safety in Railway Tunnels (SRT) TSI, specifically any current or legacy issues. The improvements and knowledge gained is expected to influence best practice in operation and maintenance. National and International Standards relating to the areas of tunnels and bridges should be affected with the objective of improving performance and safety. Industry Standards and Company Standards will not be targeted.

### Strategic impact

A summary of the strategic impacts produced by the implementation of the TD results and discoveries is given below. This is organised along three main aspects: the support to the competitiveness of the EU industry, the compliance with the EU strategic objectives, and the degree of maturity of the solutions envisaged to be realised and put into practice in the railway sector. This

is expected to provide an overview of the effects generated at larger scale by the application of the TD results.

Impact type	Shift2Rail Impact	Contribution to KPIs (large spot=high contrib.)
<b>Support the competitiveness of the EU industry</b>	Global technological leadership supported by a combination of innovation and technical standards, setting an effective advantage for the European industry <ul style="list-style-type: none"> <li>Refined philosophy for inspections will allow for further innovation.</li> </ul>	
	Increase attractiveness and competitiveness: <ul style="list-style-type: none"> <li>Increase of operational reliability (less service disruptions) through more robust systems based on proactive maintenance.</li> <li>LCC reduction (through justified demands and longer use of structures)</li> </ul>	
	Enhanced customer experience by: <ul style="list-style-type: none"> <li>Increased passenger comfort from a better maintained track geometry in transition zones</li> <li>Removal of limitations governed by poorly performing structures.</li> </ul>	
<b>Compliance with EU objectives</b>	<ul style="list-style-type: none"> <li>Promotion of modal shift: A big impact brought by the implementation of these new technologies towards avoiding service disruptions and adding new capabilities</li> </ul>	
	<ul style="list-style-type: none"> <li>Support to capacity increase: by enhanced structural monitoring structures can be utilised more efficiently</li> </ul>	
	<ul style="list-style-type: none"> <li>Better utilisation of structures and longer use will significantly reduce emission harmful for environment</li> </ul>	
	<ul style="list-style-type: none"> <li>Simplified business processes by setting functional well justified demands and reducing details in national standards.</li> </ul>	
<b>Degree of maturity of the envisaged solutions</b>	Currently most of the proposed technologies are at TRL 2 (Principles observed and the possibility of using them formulated). Some concepts will be designed. At the end of Shift2Rail it is expected that many successful concepts will be brought to TRL 6 or 7.	

### 3.5.5.5. Implementation of the work programme

#### Overall approach and methodology

The **most important challenge is to extend the life of the existing infrastructure**. This can only be done effectively by having reliable assessment methods, proactive maintenance strategy and efficient strengthening methods. In addition, the older structures must also meet requirements on structural safety and availability. Assessment, which includes all kinds of inspections and structural



health monitoring, must be enhanced by quality requirements whilst not disturbing traffic. These inspections must be done more automatically and also make further use of NDT methods. Assessment methods should also be enhanced in detecting hidden deterioration so measures can be taken in due time to eliminate long time closures for maintenance.

For bridges, one of the most important questions is the **fatigue capacity** – how much remains and how much has already been consumed. The fatigue capacity will be studied in order to be able to assess, monitor and improve it (e.g. by new and improved strengthening methods) Fatigue failures are brittle, by improving fatigue capacity by strengthening more ductile failure modes with warnings are ensured. To tackle the fatigue problems, structures should have a combination of proactive strengthening and monitoring.

There are also possibilities of **reducing load effects on structural components** whilst having the same traffic on the bridge. Relatively small measures can make existing bridges less harmful to track and vehicles at the same time as the traffic load being less harmful for the bridge. Improved transition zones between embankment and the bridge has the potential of reducing stress on the bridge and improving structural behaviour on bridges subjected to high speed trains. Reduced stresses will reduce consumption of fatigue capacity and prolong the remaining life.

Another important area to cover is **shear** in concrete bridges and tunnels. This phenomenon has not been given the same amount of attention as bending even though shear failures occur with little or no warning. It is likely that shear weaknesses might not be monitored; instead structures should be made over strong when it comes to shear making more predictable failures critical and ensuring warning signals.

Future rail traffic will increase with higher speeds and axle loads. Even in this scenario noise and vibration must be reduced to avoid deterioration and negative reputation. Further development of rail traffic relies on society's acceptance. Therefore noise and vibrations must not increase especially in urban areas.

With better understanding and a more profound **code on dynamics**, bridges can be designed for high speed trains to be built at the same construction cost level as for bridges for ordinary speed.

Future cost and environmental savings by having more descriptive codes and standards demands that designers, contractors and authorities understand each other. It is also important that descriptive codes cover all partners' interest so that tenders are fair and bidding will not risk violate laws, policies nor ethical matters. The foundation for such descriptive codes will be negotiated in the project between represented partners. Value and costs for monitoring, repairing and strengthening must be quantified in order to make the optimal choices when constructing new structures. With **demands and requirements** on bridges and tunnels that are transparent, biddable and justifiable, innovation driven by industry is facilitated which will improve competition and competitiveness.

Important steps in the scientific and technical methodology are:

- - Define and harmonize problem description
- - Import knowledge from other industries and study their best practise



- - Identify possible solutions
- - Invent tunnel and bridge specific solutions
- - Develop new and existing solutions for proactive management. Verify/reject technologies based on testing.
- - Implement the new methods in technical demonstrators and monitor implementation effects.
- - All successes and failures must be deployed in order to improve the development process in the railway industry and to facilitate innovation driven by industry.

**High Level Task Breakdown**

Task	Task Name	Task Description	Lighthouse Project Contribution (% / Budget €m)
Task 3.5.1	<b>Technology identification and development for tunnel inspection and data gathering.</b>	<ul style="list-style-type: none"> <li>Identify new methods for tunnel inspections</li> <li>Develop risk based inspections programme.</li> <li>Develop inspection methods with good repeatability.</li> <li>Standardise condition data gathering.</li> <li>Increased level of automation.</li> </ul>	
Task 3.5.2	<b>Repair of tunnels</b>	<ul style="list-style-type: none"> <li>Develop methods that are quick to implement and can be delivered in increments.</li> <li>Develop methods that can be implemented without disturbing traffic.</li> </ul>	
Task 3.5.3	<b>Implementation of tunnel technology</b>	<ul style="list-style-type: none"> <li>Describe reasonable and cost efficient demands on tunnel structure.</li> <li>Calibrate assessment and repairing methods by testing.</li> </ul>	
Task 3.5.4	<b>Technology identification and development for bridge assessment</b>	<ul style="list-style-type: none"> <li>Adopt technology from other industries.</li> <li>Use ordinary trains for structural health monitoring of bridges.</li> <li>Develop method with accuracy and quality so performance can be followed over time.</li> <li>Evaluate boundary conditions for bridge performance and capacity.</li> <li>Develop methods to reduce structural noise from bridges.</li> </ul>	
Task 3.5.5	<b>Repair of bridges</b>	<ul style="list-style-type: none"> <li>Develop methods of strengthening for improved fatigue capacity.</li> <li>Develop durable methods to strengthen the shear capacity of concrete structures.</li> <li>Develop methods to upgrade bridges by change of structural mode of operation.</li> <li>Improvement of transition zones.</li> </ul>	
Task 3.5.6	<b>Implementation of bridge technology</b>	<ul style="list-style-type: none"> <li>Describe bridge demands on new and existing structures.</li> <li>Calibrate assessment methods by full scale testing.</li> <li>Bridges for high speed at low cost.</li> </ul>	







**TD3.5 Budget**

The estimated budget for the TD is around 15.6M €.



### 3.5.6. TD3.6: Dynamic Railway Information Management System (DRIMS) Demonstrator

#### 3.5.6.1. Concept and objectives of the DRIMS Demonstrator

##### Context

TD3.6 DRIMS forms together with TD3.7 and TD3.8 the Intelligent Asset Management Pillar. The Intelligent Asset Maintenance Pillar is a driver or a way to make asset management according to PAS55/ISO55000 possible in the railway sector. The Intelligent Asset Management Pillar is an accelerator and driving force giving practical guidance for the implementation of a holistic asset management framework.

Approximately 25% of the annual operational cost of High Speed infrastructure is incurred by maintenance<sup>10</sup>. For conventional mixed traffic track this ratio is higher due to older infrastructure and accelerated deteriorations (due to increased usage).

The age of the current rail infrastructure is not the only cause of this massive spending on maintenance. Another reason is that typical the assets of the rail infrastructure have an expected life time of more than 30 to 50 years. Improving the situation requires that each maintenance step during the life time needs to be recorded in order to monitor its effect. The gained knowledge will be used for decisions in the future.

---

<sup>10</sup> Economic Analysis of High Speed Rail In Europe, De Rus et al., BBVA Foundation, 2009



### **Definition and justification of the objective**

TD3.6 is aimed at defining an innovative approach to existing railway data management, processing and analysis to support intelligent asset management without the need of developing either a new database or yet another asset register. To this end TD3.6 is offering innovative open standard secure privacy-compliant interfaces to heterogeneous external systems and a smart analytics framework in support of prescriptive railway maintenance and of all other railway systems and services that it may impact as follows:

Objectives	Result	Deliverable
Standard open interfaces to access existing heterogeneous multi-owner maintenance-related data.	Practical SW solutions to achieve a seamless interface with existing information with the required characteristics in the different EU railway contexts	DRIMS open interfaces and IT architectures: technical reports and SW solutions.
Analytic tools for automatic detection of anomalies	Innovative tools to reveal anomalies in the assets' status that could be precursors of faults (nowcasting and forecasting).	DRIMS approaches for anomalies automatic detection: technical reports and SW tools.
Analytic tools discovering and describing the maintenance workflow processes	Innovative tools to infer actual workflow processes and, therefore, gather behavioural patterns, allowing the uncovering and measuring of the discrepancies between models derived according to prescriptive approaches and actual process executions	DRIMS innovative approaches for discovering and describing the maintenance workflow processes: technical reports and SW tools.
Analytic tools predicting railway assets decay towards prescriptive maintenance	Innovative predictive models of decaying infrastructure assets based on data/information and relying on open standard interfaces, taking in account available physical and statistical models	DRIMS innovative approaches for decay prediction of assets: technical reports and SW tools.

### **Alignment to S2R Strategic Master Plan**

TD3.6 directly relates with the Intelligent System Maintenance research of the Master Plan. Since this research area is all about data, it is obvious that there is a strong interaction between TD3.6, TD3.7 and TD3.8. The perspective of the three TDs differs:

- TD3.7 RIMMS focuses on asset status data collection (measuring and monitoring) and processing and data aggregation producing data and/or information on the measured/monitored status of assets,
- TD3.6 DRIMS focuses on interfaces with external systems; maintenance-related data management and data mining and data analytics; asset degradation modelling covering both degradation modelling driven by data and domain knowledge and the enhancement of existing models using data/new insights, and
- TD3.8 IAMS concentrates on decision making (based also but not only on TD3.6 input); validation and implementation of degradation models based on the combination of traditional and data

driven degradation models and embedding them in the operational maintenance process based upon domain knowledge; system modelling; strategies and human decision support.

**Figure 72: Interconnection between RIMMS, DRIMS and IAMS**

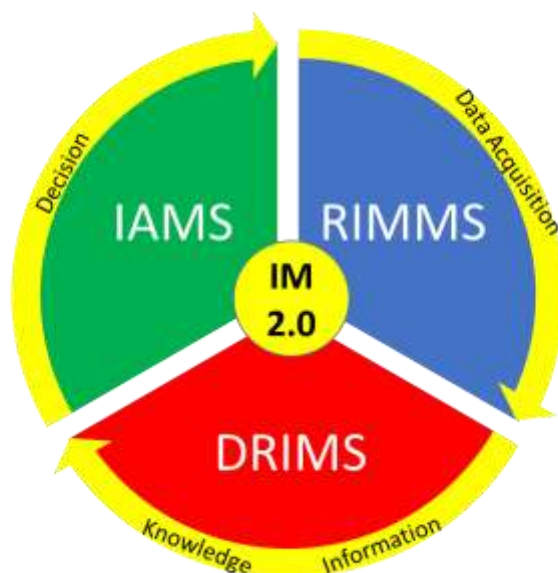

In particular, the interaction between TD3.6 and TD3.8 can be both in the Push and Pull mode: TD3.6 generates asynchronous information (push) when data patterns diverge from expected behaviour; TD3.8 either pulls synchronously information (at a given rate) from TD3.6 to update decisions or asks to perform more statistical analysis in certain situations, with specific parameters and data sets

TD3.6 is expected to receive from the different IPs the physical models corresponding to the considered asset(s) involved in each specific IP and, at the same time, while TD3.6 will provide the developed analytics tools and models to all IPs dealing with specific infrastructural assets.

Figure 73: Interactions between RIMMS, DRIMS and IAMS

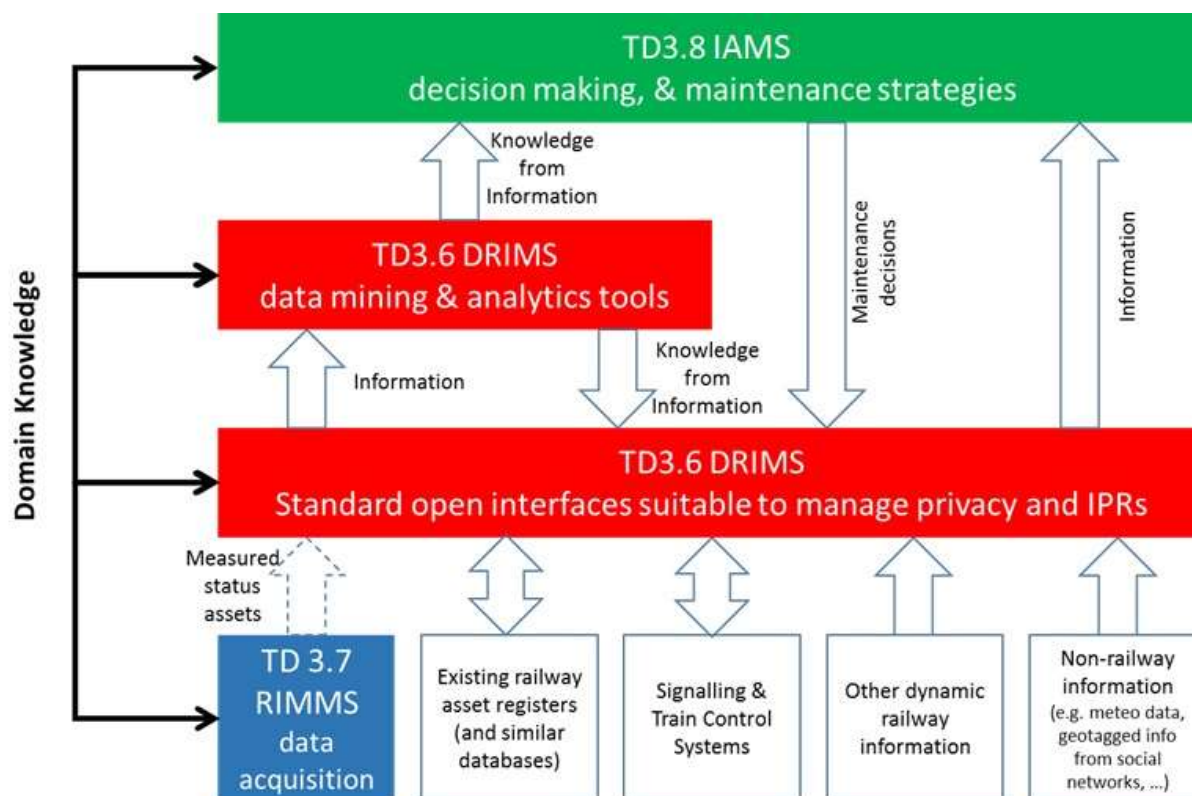

### 3.5.6.2. Technical ambition of the DRIMS Demonstrator

#### Analysis of the state-of-the-art

The current situation of railway maintenance is characterised as follows:

1. The majority of monitoring and measuring systems are designed as independent tools thus making difficult the fusion of information and its integration in the maintenance process.
2. A huge number of individual information systems is currently available in the EU railways, each of them dealing with individual and isolated areas of the maintenance process thus not exploiting the potentiality of big data analysis.
3. Research and innovation results are showing that maintenance performances are strictly linked to many heterogeneous parameters, most of them not yet taken into account in the maintenance process.
4. Typically applied maintenance is still periodic preventive maintenance based on good practices established a long time ago, simply integrated by targeted interventions when faults appear.
5. Stakeholders' environment is becoming more and more and complex due to the increasing amount of parties – often with conflicting priorities – involved in infrastructure operation and maintenance.



## Ambition

It is evident that a quantum step in rail maintenance is required to make the infrastructure fit for the upcoming challenges and achieve ambitious targets. In this context, as briefly introduced before, the TD3.6 ambition is to study, develop and test innovative approaches for data management, processing and analysis, to support intelligent asset management, without the need of developing either a new database or yet another asset register.

## Technical ambition

The DRIMS TD3.6 is proposing a breakthrough approach to overcome the above-identified difficulties allowing an **open, standardised, seamless and secure access** to railway heterogeneous data and information, covering aspects like transaction of IPR-protected B2B data, management of data with safety-critical impact, strict information assurance and related quality control procedures on data and quality gates, etc. DRIMS will also showcase how to generate **knowledge from data and/or information** – driven whenever necessary by the available domain knowledge – valid for life cycle management and intelligent asset maintenance planning within the TD3.8 ISMES module including:

- **automatic detection of anomalies** in the status of asset(s) based on the analysis of measured data and its evolution in time in order to predict in advance (nowcast and forecast) potential failures or drifts and to define the ‘normal behaviour’;
- **discovering and describing the maintenance workflow processes** (process mining) from workflow logs as they are actually being executed to infer actual workflow processes and, therefore, gather behavioural patterns, allowing the uncovering and measuring of the discrepancies between models derived according to prescriptive approaches and actual process executions;
- **implementation of predictive models** of decaying infrastructure assets based on data/information and relying on standard interfaces, eventually taking in account physical and statistical models, whenever available<sup>11</sup>.

The proposed approaches will be also suitable for integration into the practices developed by other TDs including: TD3.7, TD3.8, TD3.11, TD2.9, TD5.2 and CCA I2M.

In conclusion, the characteristics of DRIMS are extensive and complex, requiring a holistic approach and system-of-system thinking in order to develop and provide generic solutions which can easily be adapted to a specific context.

## Market Uptake

By the end of the proposed work, all the principal elements required for rapid market uptake will have been achieved. These include:

- Demonstration of the developed solutions that provide objective measures and hence give credibility and clearly show benefits;

---

<sup>11</sup> A lot of effort have been spent to find physical-based models of degradation phenomena (e.g. 6th FP INNTRACK project targeting track infrastructure), which can be exploited in a synergic way with data-driven models.

- Solutions designed to be simple to operate and interoperable, allowing for effective and efficient competition between suppliers;
- Shift2Rail will be able to provide evidence for successful system integration of the products greatly helping Infrastructure Managers to gain trust in the innovations and products;
- With the infrastructure managers as part of Shift2Rail, the products will come with a pedigree of end users needs having been properly addressed.

The "big-data" transport market is recognised by many IT advisory companies (see for example the Gartner point of view in Figure 74) as a hot market, when compared with other industries, in terms of

- volume of data
- velocity of data

**Figure 74: Comparisons of data sources by industry (source Gartner)**

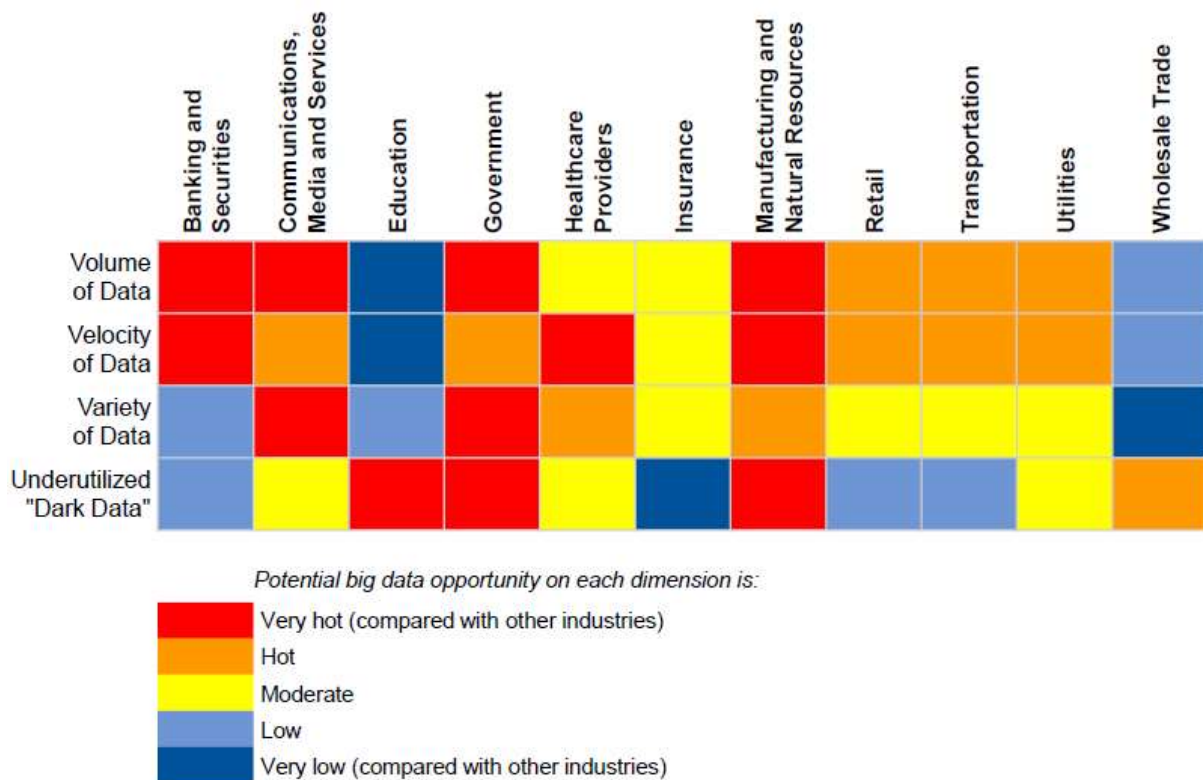

Also McKinsey Global Institute ("*Ten IT-enabled business trends for the decade ahead*", May 2013) include the Internet of Things and the "big data" advanced analytics in the 10 IT-enabled business trends for the decade ahead.

The Shift2Rail developments are therefore addressing a market ready to absorb and exploit the proposed innovations on "big data".





Moreover, the use of "big data" in railway (satellite images, geological and land utilisation data, facility logs, 3D CAD diagrams, rail line plans, etc.) and the corresponding analytics approaches can be used (apart from the already discussed adoptions in the intelligent maintenance areas) also for the information platform for 3D city spaces covering for example:

- development along railway
  - lines of real estate management
  - urban development in and around railway stations
- services
  - improved services and sales
  - emergency response plans

The DRIMS results can be exploited by:

- railway operators and infrastructure managers, by using them in their current maintenance practices;
- railway manufacturers, by using them to improve maintenance of their manufactured products.

#### **Identification of existing major technical limitations and blocking point**

Barriers and obstacles which may limit the impact of TD3.6 and reduce market uptake are:

- Resistance to change due to culture and competence through 'patterning' forming of fixed ways of behaving
- Current decision making sometimes based on subjectivity rather than actual data analysis
- Current ways of working not consistent across Europe, increases difficulty in making a universal incremental change or step-change
- Legacy systems in most of EU countries, lack of harmonisation and European disparity in technological level are an obstacle for interoperability
- Restrictions on operational data across Europe, availability/confidentiality, as well as timing systems (synchronisation) for cross-country operations
- Regulatory/legal barriers around introducing new products and techniques (i.e. national notified rules, product acceptance processes, standards and specifications)

The following major risks are foreseen for the TD.

Nº	Risk description	Mitigation action proposed
1	Data owners do not provide access to data in a timely manner	Data owners already included as partners in Shift2Rail
2	Legacy systems in most of EU countries and lack of harmonisation could limit the generic character of proposed solutions	The design will consider compatibility with legacy systems
3	Forecasting system selected technology is not optimum and output is inaccurate	Forecasting will be provided by a set of parallel algorithms in such a way that output is guaranteed
4	System outputs do not provide the expected levels of confidence due to data quality issues	Data quality checks and data cleansing will be performed. to mitigate these issues Definition of data sources and required data quality as early priority to find solutions with additional external partners/ data source
5	Expertise on data analytics and ‘big data’ not fully covered by the S2R members and – more in general – by the rail community.	It is planned both to have an Open Call involving key competences from more mature industrial sectors (e.g. banking, large networked infrastructures, etc.) and subcontracting activities to expert partners.

### References to relevant EU projects

Potential synergies can be found with the following FP7 and H2020 EU-funded research projects:

Acronym (EC Reference)	Description of Project
<b>ACEM-Rail</b> (GA 265954)	Improve the railway maintenance by the development of a highly integrated automatic system.
<b>INTERAIL</b> (GA 234040)	Integrated high-speed system for the fast and reliable inspection of rail tracks.
<b>MAINLINE</b> (GA 285121)	Improving the railway system by taking into consideration the whole life of specific infrastructure.
<b>CAPACITY4RAIL</b> (GA 605650)	Results on traffic disruption estimation from timetable data.
<b>INTEGRAIL</b> (FP6 012526)	Integration for achieving higher levels of performance of the railway system in terms of capacity, average speed and punctuality, safety and the optimized usage of resources.
<b>DRAIL</b> (GA 285162)	Integration of alarm limits, monitoring systems and vehicles; deployment plan set out based on RAMS and LCC analyses.
<b>IN2RAIL</b> (GA 635900)	Results on asset status nowcasting and forecasting applied to TMS applications.



### **3.5.6.3. Specific Demonstration activities and contribution to ITDs/SPDs**

#### **Vision**

In the Intelligent Asset Management Area of research, there will be two levels of demonstration:

- The first level will be the one focused on the TD objectives demonstration (TD3.6 DEMO);
- The second level will be an integration level (ITD) to demonstrate the overall IAM concept. (IAM ITD)

The TD3.6-DEMO does not foresee any HW development, but the design and implementation of a standardised IT architecture that will allow integration and knowledge generation from

- data, made available to the TD3.6 and TD3.8 modules through standard interfaces,
- SW modules developed in the project (prediction of anomalies, discovering and describing the maintenance workflow processes, predictive models).

The TD3.6-DEMO will be distributed both geographically and in terms of families of assets to be involved. To this end 2 main demonstrator areas, focused on independent topics, have been defined:

- The first TD3.6 demonstrator will concentrate on the **tracks** topic.
- The second TD3.6 demonstrator will be on the **S&C**.

TD3.6 will provide to TD3.8 all the necessary information and knowledge to address and feed at best maintenance activities on the above-mentioned assets (tracks and S&C).

**Figure 75: Relationship of TD3.6 with other TDs**

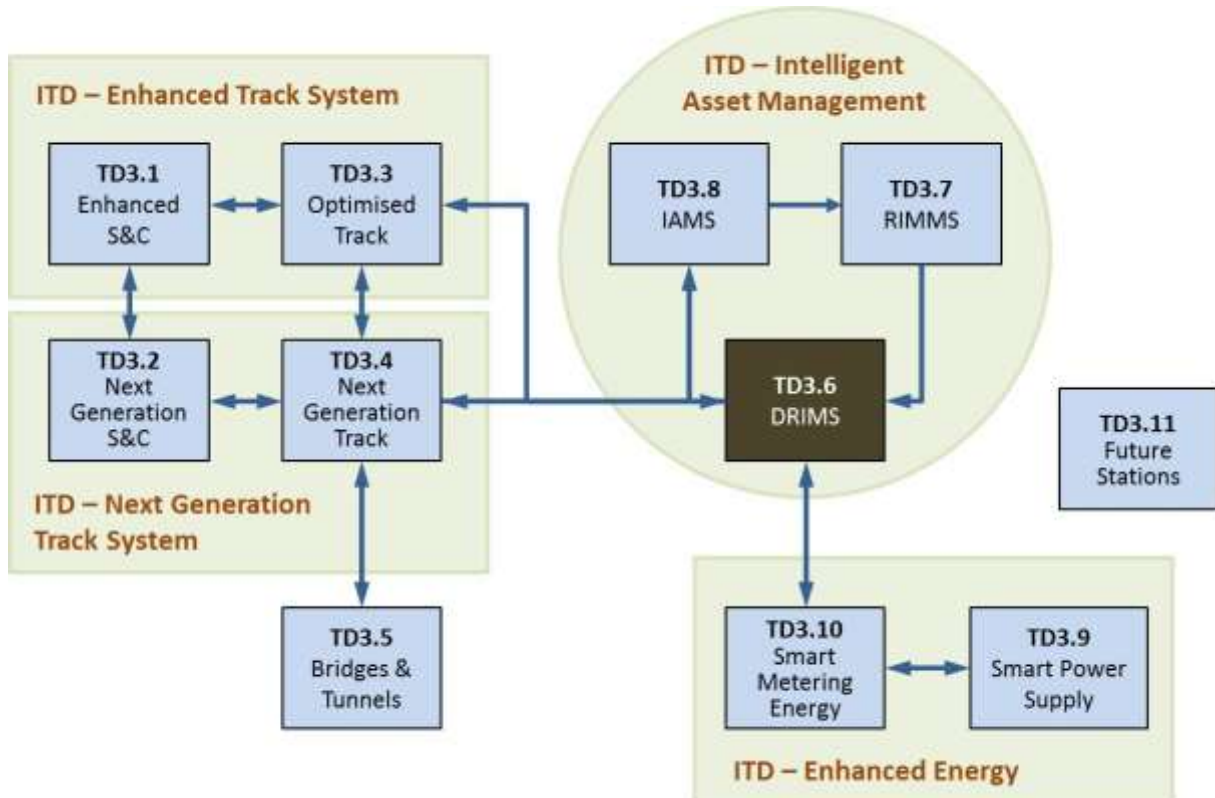

### **Approach**

To guarantee the feasibility of the innovative concepts underpinning the TD3.6-DEMO (big data and data mining, knowledge extraction, etc.) of data and information to be collected, each demonstrator must be coherent with:

- the railway area to be analysed (data must be referred to a specific area of interest in which the chosen asset – TD3.6-DEMO topics – will be tested having heterogeneous information from several sources related to what happened and what’s happening in the chosen area);
- the timing (statistic information, real time information must be coherent).

To have a very robust demonstration there is the need of a wide variety of data coming through heterogeneous sources.

The partners (mostly IM) hosting the demonstrator will provide:

- access to network, data and knowledge;
- in a standardized format (according to Task 3.6.4 results)

A cyber security compliant and privacy compliant approach to protect data and operational activities will be applied across all the demonstrators.

The ITD level will have to demonstrate the overall concept of Intelligent Asset Management: this requires the availability, in the same context, of demonstrators coming from the 3 TDs (components), and linked to the defined topic.

The ITD has to guarantee the demonstrability of the overall concept, which is the demonstration of the improvement of maintenance process and strategies (TD3.8) through knowledge extracted from information (TD3.6) coming from available data, measuring and monitoring systems (TD3.7)

The IAM-ITD components must have the following characteristics:

- coherent data set;
- consistent maintenance processes and strategies to be improved;
- measuring and monitoring systems to the scope;
- an overall standardized IT architecture and related interfaces to allow a proper seamless management of data, information and knowledge

**Figure 76: Intelligent Asset Maintenance Demonstration**

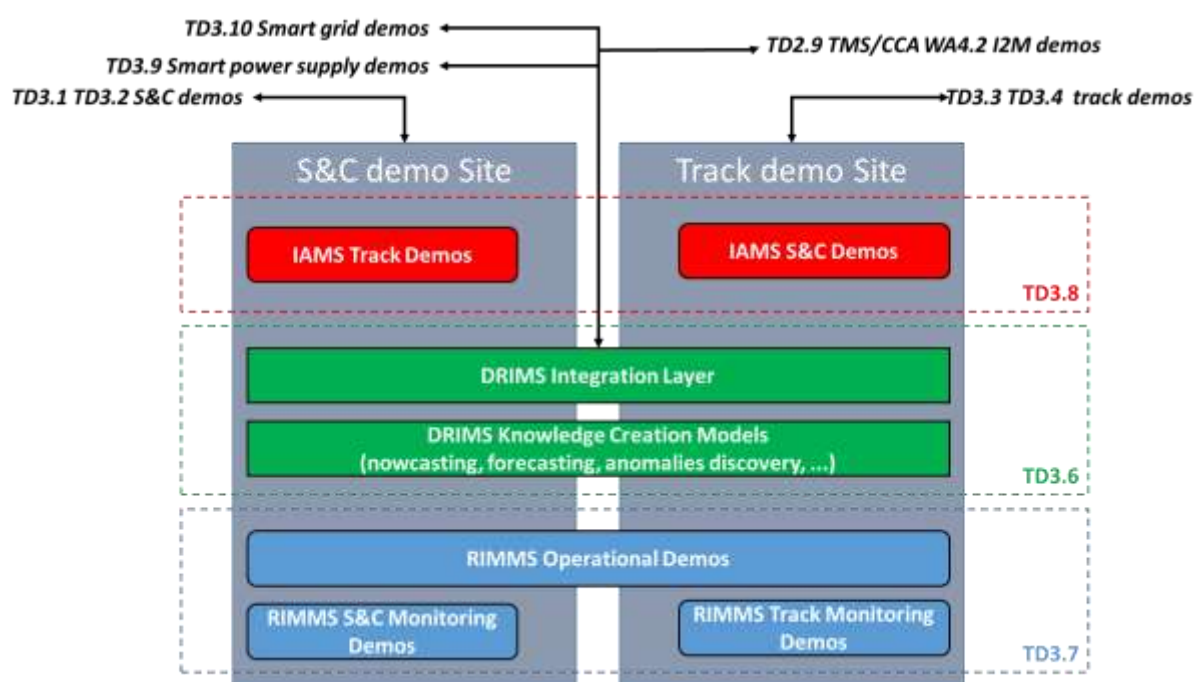

#### 3.5.6.4. Impact of the DRIMS Demonstrator

##### Benefits

"Big data" means high-volume, high-velocity and high-variety information assets that demand cost-effective, innovative forms of information processing for enhanced insight and decision making. The "big-data" transport market is recognised by many IT advisory companies as a hot market, when compared with other industries, in terms of both volume of data and velocity of data and the



Internet of Things and the "big data" advanced analytics are considered the 10 IT-enabled business trends for the decade ahead. The Shift2Rail DRIMS developments are therefore addressing a market ready to absorb and exploit the proposed innovations on "big data".

Moreover, the use of "big data" in railway and the corresponding analytics approaches can be used (apart from the already discussed adoptions in the intelligent maintenance areas) also for the information platform for 3D city spaces covering – for example – development along railway and services (e.g. improved services and sales, emergency response plans, etc.).

The DRIMS results can be exploited by railway operators and infrastructure managers, by using them in their current maintenance practices, and by railway manufacturers, by using them to improve maintenance of their manufactured products.

### **Technical Impact**

A significant impact is expected from the solutions developed in this TD, combined with the TD37 and TD38 solutions, including:

- Improvement of capacity – a large improvement in line capacity thanks to a more effective asset maintenance management supported by the solutions developed within the TD;
- Reliability – failure modes of current systems will be reduced/eliminated thanks to the new "intelligent asset management";
- Safety – as a consequence of the previous bullet point the number and magnitude of incidents will be reduced;
- Significant LCC savings should be possible, thanks to new asset management approach.

### **Contributions to TSI Standards**





TD3.6 DRIMS will contribute to the following TSIs and official or de facto standards:

- the railML.org standardisation process to create railway-specific universally applicable XML-based data exchange format
- the ERA ERA/REC/04-2011/INT Recommendation on specification of Register of Infrastructure (RINF) for what concerns the interfaces with asset registers
- the ISO 55000 (Overview, principles and terminology), 55001 (Requirements) and 55002 (Guidelines for the application of ISO 55001) international standards for Asset Management
- adoption of asset status information protocol compliant with ISO8000 (data quality) and ISO13374 (representation levels).
- possible contribution to the UIC International Railway Standard (IRS) IRS 30100 RailTopoModel, a logical model to standardise the representation of railway infrastructure-related data.



The use of a set of standard open interfaces to access heterogeneous multi-owner maintenance-related data with the adequate degree of privacy, trust ability, security and quality will help to improve the cooperation between the different stakeholders to achieve a win to win situation.

**Strategic impact**

Impact type	Shift2Rail Impact	Contribution to KPIs (large spot=high contrib.)
<b>Support the competitiveness of the EU industry</b>	<ul style="list-style-type: none"> <li>• Global technological leadership supported by a combination of innovation and technical standards, setting an effective advantage for the European industry: TD3.6 DRIMS will contribute to the following TSIs and official or de facto standards:               <ul style="list-style-type: none"> <li>○ the railML.org standardisation process to create railway-specific universally applicable XML-based data exchange format</li> <li>○ the ERA ERA/REC/04-2011/INT Recommendation on specification of Register of Infrastructure (RINF) for what concerns the interfaces with asset registers</li> <li>○ the ISO 55000 (Overview, principles and terminology), 55001 (Requirements) and 55002 (Guidelines for the application of ISO 55001) international standards for Asset Management</li> <li>○ adoption of asset status information protocol compliant with ISO8000 (data quality) and ISO13374 (representation levels).</li> </ul> </li> </ul> <p>The use of a set of standard open interfaces to access heterogeneous multi-owner maintenance-related data with the adequate degree of privacy, trustability, security and quality will help to improve the cooperation between the different stakeholders to achieve a win to win situation.</p> <p>TD3.6 DRIMS will contribute to introduce the Internet of Things and the 'big data' advanced analytics which are considered among the IT-enabled business trends for the decade ahead.</p>	
	<ul style="list-style-type: none"> <li>• Increase attractiveness and competitiveness:               <ul style="list-style-type: none"> <li>○ Increase of <b>operational reliability</b> (less service disruptions) through more robust systems based on less physical components, enhanced assessment and debugging concepts, and more flexible processing of information: predictive maintenance (i.e. a proper combination of TD3.6, TD3.7 and TD3.8 tools and procedures) can sensibly reduce and better estimate the required occupation time and therefore heavily improve the overall operational reliability.</li> </ul> </li> </ul>	
	<ul style="list-style-type: none"> <li>○ <b>Reduce</b> cost: predictive maintenance (i.e. a proper combination of TD3.6, TD3.7 and TD3.8 tools and procedures) guarantee an optimisation in the maintenance activities, guaranteeing a cost reduction both in terms of spare parts and in terms of effort.</li> </ul>	
	<ul style="list-style-type: none"> <li>• <b>Increase capacity</b> more than increasing capacity, a modern and more cost-effective approach to maintenance can contribute to maintain the target capacity of the network and, in certain specific cases, also to slightly increase it.</li> </ul>	



Impact type	Shift2Rail Impact	Contribution to KPIs (large spot=high contrib.)
<b>Compliance with EU objectives</b>	<ul style="list-style-type: none"> <li>• <b>Achieve single European Rail Area (SERA):</b> a standardized approach to the maintenance information and activities like the one developed within the TD3.6 will reduce the technical obstacles for a proper interconnection of technical solutions.</li> </ul>	●
	<ul style="list-style-type: none"> <li>• <b>Enhanced interoperability:</b> improving standardisation and open interfaces to access data will guarantee that information can be used by different organisations for performing the maintenance activities</li> </ul>	●
<b>Degree of maturity of the envisaged solutions</b>	In mature ICT sectors like banking, aerospace and finance, analytics approaches are at TRL 7, 8 and, in some cases, 9 while in the railway sector are currently at TRL2/3. All the process mining approaches are currently at TRL2/3 in all sectors except manufacturing where they are at TRL 5. At the end of Shift2Rail it is expected that the successful DRIMS concepts are brought to TRL 6/7.	

### 3.5.6.5. Implementation of the work programme

#### Overall approach and methodology

The work-programme will be implemented through 6 technical tasks and a horizontal coordination task as described in Figure 77.

**Figure 77: Task breakdown structure for TD3.6**

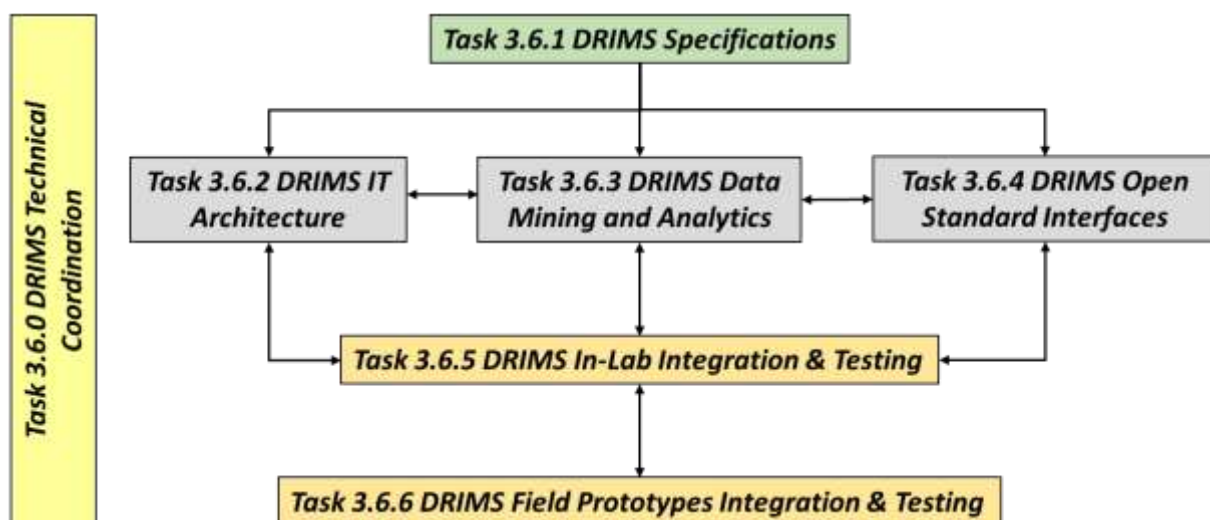



### **Clarification of input of Lighthouse project**

Some of the results of IN2RAIL can pave the road of TD3.6 (as example for DRIMS) mostly with limited IPR issues

- standardised data format for TMS
- results of the nowcasting & forecasting for TMS

**High Level Task Breakdown**

Task	Task Name	Task Description	Lighthouse Project Contribution (% / Budget €m)
<b>Task 3.6.1</b>	<b>DRIMS Specifications</b>	<p>This task is aimed at specifying the DRIMS high-level characteristics covering:</p> <ul style="list-style-type: none"> <li>• the business cases and the consequent target knowledge;</li> <li>• the assets involved, the level of granularity necessary for their description and the level of criticality for the RAMS/LCC analysis in TD3.8;</li> <li>• the legal constraints to be considered in DRIMS at the national and EU level;</li> <li>• the assessment of the European regional disparities in terms of railway characteristics, data availability and maintenance approaches and policies;</li> <li>• the interactions between DRIMS and the different Shift2Rail modules and functions;</li> <li>• the policies to manage the DRIMS interfaces with existing heterogeneous sources of information during the Shift2Rail life.</li> </ul>	
<b>Task 3.6.2</b>	<b>DRIMS IT Architecture</b>	<p>This task will deal with the definition of the DRIMS IT architecture and will study and contribute to specify:</p> <ul style="list-style-type: none"> <li>• the more appropriate distributed data management and flows architectures possibly utilising open and license-free standards;</li> <li>• the privacy and IPRs management approaches;</li> <li>• the interaction with the different heterogeneous sources of information including the existing asset registers to avoid duplication of existing information;</li> <li>• the required IT security approaches to guarantee an adequate protection of the information coupled with the desired open interfaces;</li> <li>• the selection of the possible data-management approaches;</li> <li>• the required levels level of resilience of the DRIMS module.</li> </ul>	

Task	Task Name	Task Description	Lighthouse Project Contribution (% / Budget €m)
<b>Task 3.6.3</b>	<b>DRIMS Data Mining and Analytics</b>	<p>Task 3.6.3 will be centred on the study, design and development of innovative data-centred, IPR-compliant, ‘safe and secure’ approaches for analytics, data correlation, mining and algorithms definition towards:</p> <ul style="list-style-type: none"> <li>• Automatic Detection of Anomalies;</li> <li>• Process Mining;</li> <li>• Predictive Models of Decaying Infrastructures based on data and, if available, supported by physical models.</li> <li>• This activity will also study and design: <ul style="list-style-type: none"> <li>• the best possible approaches to disclose to human operators, KPIs and other information through the use of visual analytics tools;</li> <li>• data cleansing approaches. <ul style="list-style-type: none"> <li>○ This task will be centred on the 2 main assets identified for the demonstrations – tracks and S&amp;C.</li> </ul> </li> </ul> </li> </ul>	
<b>Task 3.6.4</b>	<b>DRIMS Open Standard Interfaces</b>	<p>The objective of this task is to explore the current state of the art concerning the retrieval, distribution and exploitation of open data, available throughout heterogeneous networks</p> <p>The task will also focus on:</p> <ul style="list-style-type: none"> <li>• overcoming inhomogeneous data semantics/syntax of data from heterogeneous sources will be also considered;</li> <li>• data distribution protocols and data compression methodologies;</li> <li>• increasing interoperability issues with BIM, open data and railML (UIC-RailTopoModel) interfaces.</li> </ul>	
<b>Task 3.6.5</b>	<b>DRIMS In-Lab Integration and Testing</b>	<p>This task will allow the in-laboratory integration and testing of the DRIMS prototypes before integrating them infield in order to get the first implementation in a controlled environment and report feedback to the RIMMS and IAMS modules for design refinements of the innovative approaches. The objectives are:</p> <ul style="list-style-type: none"> <li>• Throughout the project, to foster and ease the in-lab integration of the different parts, which the DRIMS approach consists of, in order to realize a proof-of-concept working prototype, ready to be tested in the application scenarios;</li> <li>• To verify that the system delivers as user expects and complies with the specifications.</li> </ul>	

Task	Task Name	Task Description	Lighthouse Project Contribution (% / Budget €m)
Task 3.6.6	<b>DRIMS Field Prototypes Integration and Testing</b>	<p>The demonstration will be managed according to a multi-layer approach:</p> <ul style="list-style-type: none"> <li>• a TD3.6 specific field demonstration where the solutions developed within the TD will be individually tested;</li> <li>• an Integrated Demonstration at the I2M level (TD3.6, TD3.7 and TD3.8) concentrated on 2 core assets: tracks and S&amp;C.</li> <li>• The objectives of this task are:</li> <li>• Identification of one or more field test sites and related information sources to test the different modules developed in DRIMS;</li> <li>• To verify that the system delivers as user expects and complies with the specifications in real in-field environments,</li> <li>• To test of the DRIMS concept as a whole, to check the normal operation of the system, and the specific validation of the effectiveness, consistency and correctness of the data collection and processing versus identified requirements at the in-field level.</li> </ul>	

**3.5.6.6. Planning and budget**

**TD3.6 Gantt Chart**

TD3.6 - DRIMS DEMONSTRATOR		2015				2016				2017				2018				2019				2020				2021				2022				2023				2024							
Task	Description	Q1	Q2	Q3	Q4	Q1	Q2	Q3	Q4	Q1	Q2	Q3	Q4	Q1	Q2	Q3	Q4	Q1	Q2	Q3	Q4	Q1	Q2	Q3	Q4	Q1	Q2	Q3	Q4	Q1	Q2	Q3	Q4	Q1	Q2	Q3	Q4	Q1	Q2	Q3	Q4				
3.6.1	DRIMS Specifications																																												
3.6.2	IT architecture																																												
3.6.3	Data mining and analytics																																												
3.6.4	Open standard interfaces																																												
3.6.5	In-lab integration and testing																																												
3.6.6	Field prototype integration and testing																																												

**TD3.6 Budget**

The estimated budget for the TD is around 14.2M€.



### 3.5.7. TD3.7: Railway Integrated Measuring and Monitoring System (RIMMS) Demonstrator

#### 3.5.7.1. Concept and objectives of the RIMMS Demonstrator

##### Context

TD 3.6 DRIMS forms together with TD 3.7 and TD3.8 the Intelligent Asset Management Pillar. The Intelligent Asset Maintenance Pillar is a driver – or a way – to make asset management according to PAS 55/ISO 55000 possible in the railway sector. The Intelligent Asset Management Pillar is an accelerator and driving force giving practical guidance for the implementation of a holistic asset management framework.

According to several economic studies, here below the results of one of them on High Speed lines in 2009 (12), approximately the 25% of the annual operational cost of High Speed infrastructure is incurred by maintenance. For conventional mixed traffic track this ratio is higher due to older infrastructure and accelerated deteriorations (due to increased usage).

The age of the current rail infrastructure is not the only cause of this massive spending on maintenance. Another reason is that typical the assets of the rail infrastructure have an expected life time of more than 30 to 50 years and has therefore a long lasting life time, rather than being a disposable asset which would be replaced rapidly. Improving the situation requires that each maintenance step during the life time needs to be recorded in order to monitor its effect. The gained knowledge will be used for decisions in the future.

The need of improvement in technology and automisation is also clear from the several infrastructure inspection activities which are done manually by maintenance staff. These inspections are time (money) consuming and generate a lot of risks for the personnel involved.

##### Definition and justification of objectives

In this context the **TD3.7 Railway Integrated Measuring and Monitoring System (RIMMS)** is aimed at defining an integrated set of cutting-edge on-board and wayside asset-specific measuring and monitoring sub-systems in order to collect and deliver the status data of the railway system (infrastructure and rolling stock) using:

- Asset-specific Train-borne Measuring and Monitoring Systems (TMMS) for infrastructures;
- Asset-specific Wayside Measuring and Monitoring Systems (WMMS) for rolling stock and infrastructure;
- Integrated TMMS/WMMS asset specific infrastructure measuring and monitoring tools;
- Innovative drone- and/or satellite-based Remote-Sensing Measuring and Monitoring tools (RMMS).

The TD3.7 will adopt the following approach: measuring relevant data using the most innovative techniques; processing data in order to generate relevant maintenance infrastructure-related

---

<sup>12</sup> Economic Analysis of High Speed Rail In Europe, De Rus et al., BBVA Foundation, 2009

information; generating data/information to feed – using a standardized representation layer – both the TD3.6 and TD3.8 models/algorithms to support maintenance and asset management processes.

Objectives	Result	Deliverable
Development of three different track monitoring system: track geometry monitoring; rail temperature stress monitoring; satellite/drones monitoring.	A system prototype demonstration of innovative track geometry and rail stress measuring and monitoring systems. An experimental proof of concept of innovative satellite/drones monitoring systems.	Track monitoring systems: technical reports and HW/SW solutions.
Development of sensors systems embedded in S&Cs	A system prototype demonstration of innovative sensors embedded in switches & crossings.	Sensors systems embedded in S&Cs: technical reports and HW/SW solutions.
Development of signalling systems: track circuits and axle counter; radio integrity detector systems; balises monitoring systems.	A system prototype demonstration of innovative signalling-specific measuring and monitoring systems.	Signalling systems monitoring: technical reports and HW/SW solutions.
Development of operations measuring and monitoring systems: pantograph; rolling stock 3D profile; Innovative measurement of train load and wheel defects; alternative rolling stock identifications.	A system prototype demonstration of innovative operations measuring and monitoring systems.	Operations measuring and monitoring systems: technical reports and HW/SW solutions.
Automation of in-field operators inspections		

### **Alignment to S2R Strategic Master Plan**

TD3.7 directly relates with the Intelligent System Maintenance research of the Master Plan. Since this research area is all about data, it is obvious that there is a strong interaction between TD3.6, TD3.7 and TD3.8 (see Figures 72 and 73 above). The perspective of the three TDs differs:

- TD3.7 RIMMS focuses on asset status data collection (measuring and monitoring) and processing and data aggregation producing data and/or information on the measured/monitored status of assets
- TD3.6 DRIMS focuses on interfaces with external systems; maintenance-related data management and data mining and data analytics; asset degradation modelling covering both degradation modelling driven by data and domain knowledge and the enhancement of existing models using data/new insights.
- TD3.8 IAMS concentrates on decision making (based also but not only on TD3.6 input); validation and implementation of degradation models based on the combination of traditional and data driven degradation models and embedding them in the operational maintenance process based upon domain knowledge; system modelling; strategies & human decision support.





### **3.5.7.2. Technical ambition of the RIMMS Demonstrator**

#### **Analysis of the state-of-the-art**

The current situation of railway maintenance is characterised as follows:

- The majority of monitoring and measuring systems are designed as independent tools thus making difficult the fusion of information and its integration in the maintenance process.
- A huge number of individual information systems is currently available in the EU railways, each of them dealing with individual and isolated areas of the maintenance process.
- Research and innovation results are showing that maintenance performances are strictly linked to many heterogeneous parameters, most of them not yet taken into account in the maintenance process.
- Typically applied maintenance is still periodic preventive maintenance based on good practices established a long time ago, simply integrated by targeted interventions when faults appear.
- Stakeholders' environment is becoming more and more and complex due to the increasing amount of parties – often with conflicting priorities – involved in infrastructure operation and maintenance.

#### **Ambition**

From the current situation depicted above, appears that the railway sector is facing a new opportunity that is the one to introduce innovation in the maintenance programmes through the driving factor of contracted services. This economical trend deserves attention especially in respect of the JTI instrument. It is a matter of fact that, as more the market becomes service oriented, as much the industrial competitiveness moves from most traditional standalone system embedded innovation technology to other criteria that are more typically associated to service supply (e.g. punctuality and professionalism in service supply, economical models, etc). It is evident that a quantum step in rail maintenance is required to make the infrastructure fit for the upcoming challenges and achieve ambitious targets.

#### **Technical ambition**

The TD3.7 is therefore structured to build a common measuring and monitoring data representation layer suitable to elaborate data coming from all source segments (onboard, wayside and remote), in order to correlate the different data and to obtain a holistic view of the railway system conditions. It will be composed by an integrated set of cutting-edge on-board and wayside asset-specific measuring and monitoring sub-systems in strict coordination with the developments in TD3.6 (for what concerns the standardised representation layers) and TD3.8 (for what concerns the optimisation of maintenance processes). The ambition of the TD3.7 is therefore to use a holistic railway system approach, through measuring and monitoring tools, to:

- Identify, within the most critical railway sub-systems, parameters and items that represent the greatest potential to improve capacity and assets utilisation;



- Identify the minimum set of parameters to be measured in order to obtain the necessary information to characterise the railway subsystems and assets statuses;
- Fill the current technological gaps by applying cutting edge technological instruments giving the most complete and precise information on the most critical infrastructure parameters;
- Provide integration of these data/information in an intelligent asset maintenance system, giving the possibility of their usage in novel ways;

### **Market Uptake**

By the end of the proposed work, all the principal elements required for rapid market uptake will have been achieved. These include:

- Demonstration of technologies in a real operation environment that provide objective measures and hence give credibility and clearly show benefits;
- Products and systems that are developed for easy and high quality manufacturing;
- Solutions designed to be simple to operate, easy to maintain, completely interoperable and full inter-compatibility, allowing for effective and efficient competition between suppliers;
- Shift2Rail will provide products and systems that have been independently assessed for compliance with European standards and requirements giving confidence to Infrastructure Managers and permitting rapid deployment;
- Shift2Rail will be able to provide evidence for successful system integration of the products greatly helping Infrastructure Managers to gain trust in the innovations and products;

### **Technical Limitations/Barriers**

The barriers to innovation in Shift2Rail include many themes and may be **[P]**olitical, **[Ec]**onomic, **[S]**ocietal, **[T]**echnological, **[L]**egislative, **[En]**vironmental in their nature. The bullet points below identify the barriers and obstacles which may limit the impact of TD 3.7:

- Lack of long-term vision reduces uptake of innovative solutions **[P]**
- Existing contractual agreements framework restrict uptake of new technologies **[Ec]**
- Resistance to change due to culture & competence through ‘patterning’ (forming of fixed ways of behaving) **[S]**
- Current decision making sometimes based on subjectivity rather than actual data analysis **[S]**
- Current ways of working not consistent across Europe, increases difficulty in making a universal incremental change or step-change **[S]**
- European disparity in technological level **[T]**
- Regulatory/legal barriers around introducing new products and techniques – i.e. national notified rules; national product acceptance processes; national standards; and specifications **[L]**

- Climatic variation across Europe affecting compatibility, interoperability, and standardisation [En]

A certain number of risks withhold on the RIMMS TD. These classify into general risks common to the whole Shift2Rail instrument and more specific ones to the RIMMS TD. The risks more specifically related to the RIMMS TD are the following:

Nº	Risk description	Mitigation action proposed
1	Cooperation problems	Previous to starting the activities, a common cooperation framework needs to be defined, with working methodology and tools to be used at task level, ... Task Technical Coordination is established in order to minimize cooperation problems.
2	Availability of data from railway undertakings	The level of investments and high level of development of railway undertakings participation provides a sound basis for data availability.
3	Conflicts on IPRs management on data ownership	TD3.6 has set up a specific task (TD6.11) to deal with the use and management of IPR protected information. This task will allow to define the correct practices to manage the IPR protected information and to manage B2B transactions.
4	Large disparities at the EU level in the current level of innovation in maintenance practices	The establishment of a stakeholder group representing the different EU areas will allow first of all to identify the issues related to disparities. The Technical Coordination tasks will allow to drive the DRIMS development to tackle the identified issues using, as far as possible, progressive adoption steps.
5	Lacking confidence for the adoption of the proposed innovation	To borrow success stories from more mature sectors (e.g. health case for process mining)
6	Interaction and interface with other IPs	Periodical meetings between IP leaders to enumerate and define interfaces and interactions
7	RIMMS Technological Risk	Make the innovation stemming by a real maintenance efficiency paradigm rather than through the single technology systems improvement.
8	RIMMS Economical Risk	Adopt the strategic approach, that is the PPIMS (Performance, Process, Information, Monitor, Standard (source: UIC Report on Monitoring Track Conditions [1]) all along the life of the project
9	RIMMS On site Risk	Establish a tighten link between the industry suppliers and the railway stakeholders in charge of the maintenance processes

### References to relevant EU projects

In recent years there have been several research projects that have addressed more or less directly the issue of maintenance. The TD3.7 development will be directly related with the following past or on-going research projects:

Acronym (EC Reference)	Description of Project
<b>ACEM-Rail</b> (GA 265954)	Improve the railway maintenance by the development of a highly integrated automatic system.
<b>INTERAIL</b> (GA 234040)	Integrated high-speed system for the fast and reliable inspection of rail tracks.
<b>MAINLINE</b> (GA 285121)	Improving the railway system by taking into consideration the whole life of specific infrastructure.
<b>CAPACITY4RAIL</b> (GA 605650)	Results on traffic disruption estimation from timetable data.
<b>INTEGRAIL</b> (FP6 012526)	Integration for achieving higher levels of performance of the railway system in terms of capacity, average speed and punctuality, safety and the optimized usage of resources.
<b>DRAIL</b> (GA 285162)	Integration of alarm limits, monitoring systems and vehicles; deployment plan set out based on RAMS and LCC analyses.
<b>IN2RAIL</b> (GA 635900)	Results on asset status nowcasting and forecasting applied to TMS applications.
<b>INNTRACK</b> (GA 31415)	Analysis of major track cost drivers to reduce maintenance costs for sub-structure, track, S&C including LCC and logistics aspects
<b>SAFTInspect</b> (GA 314949)	The SAFTInspect project aims to enable efficient in-service sub-surface inspection of manganese rail crossings by applying an ultrasonic inspection technique called Synthetic Aperture Focusing Technique (SAFT).
<b>AUTOMAIN</b> (GA 265722)	Research results on mechanised track maintenance and inspection (tamping and grinding); LEAN analysis of working methods and processes to reduce possession times; demonstration of advanced switch monitoring; decision support methodologies and algorithms for maintenance planning and scheduling; elaborated distinction between "inspection" and "monitoring"
<b>SMARTRAIL</b> (GA 285683)	Complimentary to MAINLINE with a life cycle assessment tool for other structures.
<b>EURAXLES</b> (GA)	
<b>MAXBE</b> (GA)	

#### **3.5.7.3. Specific Demonstration activities and contribution to ITDs/SPDs**

In the Intelligent Asset Maintenance Area of research, there will be two levels of demonstration:

- The first level will be the one focused on the TD objectives demonstration (TD3.7 DEMO);

- The second level will be an integration level (ITD) to demonstrate the overall Intelligent Asset Management concept (IAM ITD).

**Figure 78: Relationship of TD3.7 with other TDs**

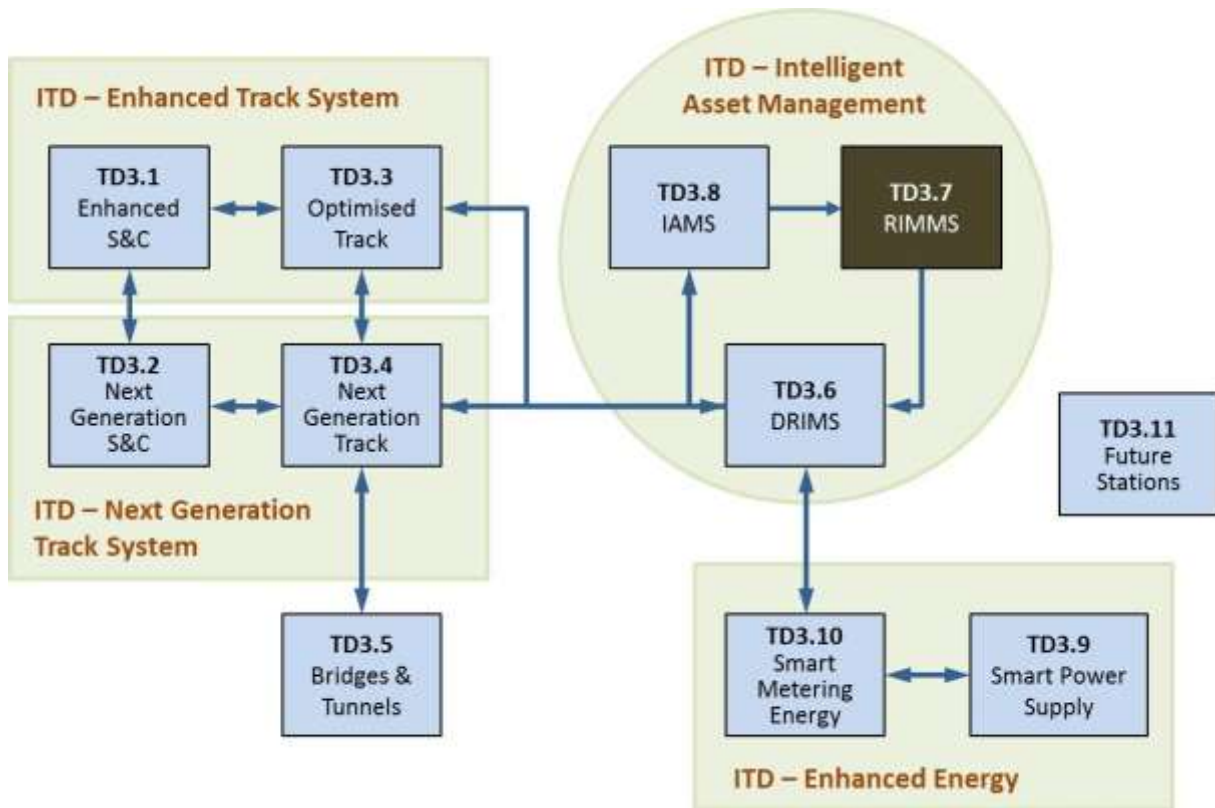

The *TD3.7-DEMO* will foresee the on field test and validation of several monitoring solutions designed and developed during the project, based on cutting-edge on-board and wayside asset-specific measuring and monitoring sub-systems adopting the following approach:

- measuring relevant data using the most innovative techniques;
- processing them in order to generate relevant maintenance infrastructure-related information;
- generating data/information to feed both the TD3.6 and TD3.8 models/algorithms to support maintenance and asset management processes.

The TD3.7 will perform 'physical' demo distributed both geographically and in terms of families of assets to be involved. To this end 4 main demonstrator areas have been defined (each of them is related to a specific task of the TD3.7 as described in the following paragraphs):

- Track geometry and Rail Thermal stress;
- Switches and Crossings (S&C);
- Signalling;

- Operations.

The TD3.7 tasks will design and develop, for each specific demonstrator area described above, monitoring systems based on the integration of various technological solutions. All these systems will be first verified in the laboratories before being transferred to the field in order to be tested and validated in a real context. The sites that will host the monitoring systems related to each demonstrator area will be identified with the IM partners of the project who will have to provide access to network, data and knowledge in order to maximize the results of the demonstrators.

To ensure a perfect integration with the other Intelligent Asset Maintenance TDs all the data collected on the field will be made available to the TD3.6 and TD3.8 modules through standard interfaces.

The ITD level will have to demonstrate the overall concept of Intelligent Asset Maintenance: this requires the availability, in the same context, of demonstrators coming from the 3 TDs (components), and linked to the defined topic. The ITD has to guarantee the demonstrability of the overall concept, which is the demonstration of the improvement of maintenance process and strategies (TD3.8) through knowledge extracted from information (TD3.6) coming from available data, measuring and monitoring systems (TD3.7).

**Figure 79: Intelligent Asset Maintenance Demonstration**

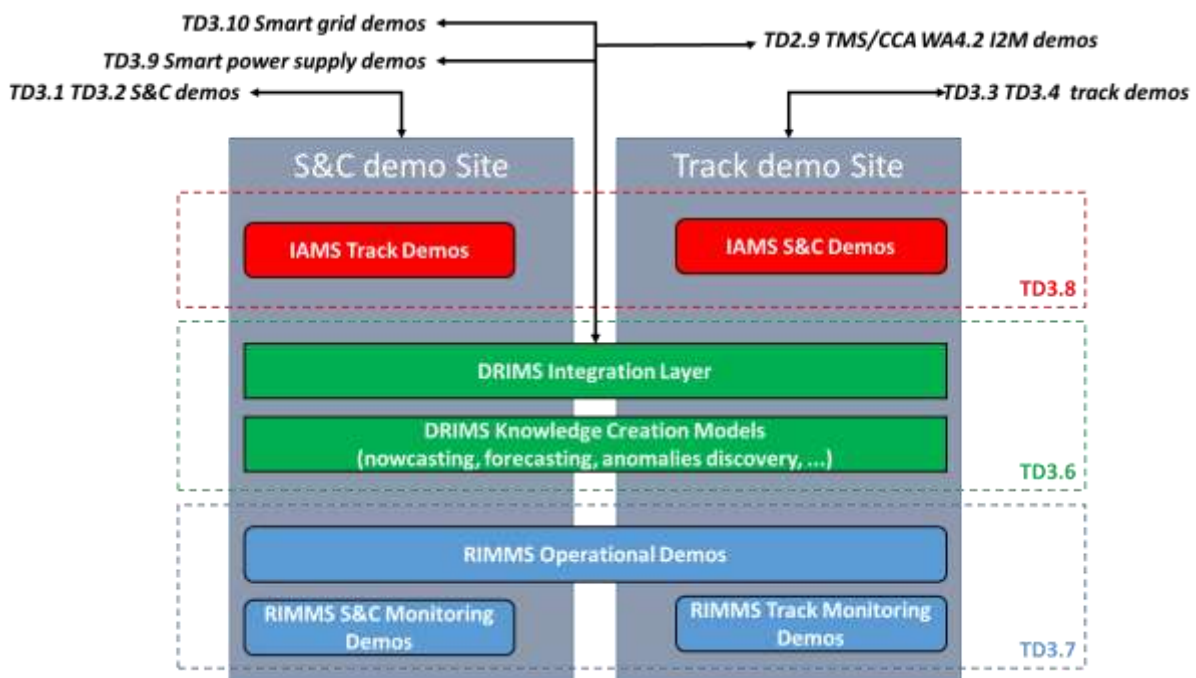

The IM-ITD components must have the following characteristics:

- coherent data set;
- consistent maintenance processes and strategies to be improved;
- measuring and monitoring systems to the scope;



- an overall standardized IT architecture and related interfaces to allow a proper seamless management of data, information and knowledge.

#### **3.5.7.4. Impact of the RIMMS Demonstrator**

##### **Benefits**

The following business benefits will be accrued from TD3.7:

- Increase of operational reliability (less service disruptions) through more robust systems based on less physical components, enhanced assessment and debugging concepts, and more flexible processing of information.
- LCC reduction (lower physical complexity of systems, increased reliability ....)
- Make the European market increase the final customer mobility satisfaction by becoming more and more ambitious in terms of capacity and long distance coverage.

##### **Technical Impact**



A significant impact is expected from the technologies developed in this TD, combined with the TD36 and TD38 solutions, including:

- Improvement of capacity – a large improvement in line capacity thanks to a more effective maintenance management supported by the here developed monitoring solutions;
- Reliability – failure modes of current systems will be reduced/eliminated thanks to the new “intelligent asset management”;
- Safety – as a consequence of the previous bullet point the number and magnitude of incidents will be reduced;
- Significant LCC savings should be possible, thanks to new asset management approach.







##### **Contribution to TSI Standards**

As Infrastructure measuring and monitoring practices are concerned, STANDARDS do not yet exist. Making a step forward towards establishment of the latter is an important aspect expected to be covered by the Shift2Rail activities as a whole programme. Given the impact of certain maintenance practices to safety issues, it may be cited that under this TD, an impact may be generated with regard to TAF (Telematic Application for Freight).

**Strategic impact**

Impact type	Shift2Rail Impact	Contribution to KPI's (large spot = high contribution)
Contribution to impacts set out in the Master Plan	<p>The specific benefits have a relevant impact on the Shift2Rail system-level KPIs. The relative weighting of the benefits provided by the joint actions of TD3.6, TD3.7 and TD3.8 on the overall system-level KPIs are estimated (over a total of 100%) as:</p> <ul style="list-style-type: none"> <li>Capacity (10%): more than increasing capacity, a modern and more cost-effective approach to maintenance can contribute to maintain the target capacity of the network and, in certain specific cases, also to slightly increase it. Self-sufficient sensor systems for comprehensive asset status information, predictive maintenance strategies &amp; maintenance decision support tools reduce disturbances in operations by 40%</li> </ul>	
	<ul style="list-style-type: none"> <li>Operational reliability (50%): predictive maintenance (i.e. a proper combination of TD3.6, TD3.7 and TD3.8 tools and procedures) can sensibly reduce and better estimate the required occupation time and therefore heavily improve the overall operational reliability.</li> </ul>	
	<ul style="list-style-type: none"> <li>Reduced operating costs (40%): improved and more intelligent maintenance actions can significantly contribute to the reduction of maintenance costs and therefore to increase competitiveness of both infrastructure owners and train operators.</li> </ul>	



Impact type	Shift2Rail Impact	Contribution to KPIs (large spot=high contrib.)
Support the competitiveness of the EU industry	<ul style="list-style-type: none"> <li>• <b>Global technological leadership supported by a combination of innovation and technical standards, setting an effective advantage for the European industry:</b> TD3.7 RIMMS is highly focused on innovative technologies, which must be cut off ones, more robust and easy to use and integrate. The Measuring and Monitoring tools must be integrated in the Intelligent Asset Management System, so they must send data through standard open interfaces (defined in the TD3.6). The use of a set of standard open interfaces to access heterogeneous multi-owner maintenance-related data with the adequate degree of privacy, trustability, security and quality will help to improve the cooperation between the different stakeholders to achieve a win to win situation.</li> </ul>	
	<ul style="list-style-type: none"> <li>• Increase attractiveness and competitiveness:               <ul style="list-style-type: none"> <li>○ <b>Increase of operational reliability</b> (less service disruptions) through more robust systems based on less physical components, enhanced assessment and debugging concepts, and more flexible processing of information: predictive maintenance (i.e. a proper combination of TD3.6, TD3.7 and TD3.8 tools and procedures) can sensibly reduce and better estimate the required occupation time and therefore heavily improve the overall operational reliability.</li> </ul> </li> </ul>	
	<ul style="list-style-type: none"> <li>○ <b>Reduce cost:</b> predictive maintenance (i.e. a proper combination of TD3.6, TD3.7 and TD3.8 tools and procedures) guarantee an optimisation in the maintenance activities, guaranteeing a cost reduction both in terms of spare parts and in terms of effort.</li> </ul>	
	<ul style="list-style-type: none"> <li>• <b>Increase capacity</b> more than increasing capacity, a modern and more cost-effective approach to maintenance can contribute to maintain the target capacity of the network and, in certain specific cases, also to slightly increase it.</li> </ul>	
Compliance with EU objectives	<ul style="list-style-type: none"> <li>• <b>Achieve single European Rail Area (SERA):</b> a standardized approach to the maintenance information and activities like the one developed within the Intelligent Asset Management System, will reduce the technical obstacles for a proper interconnection of technical solutions developed within the TD3.7</li> </ul>	
	<ul style="list-style-type: none"> <li>• <b>Promotion of modal shift:</b> the impact brought by the implementation of these new technologies can enhance the attractiveness of the Railway System due</li> </ul>	
	<ul style="list-style-type: none"> <li>• <b>Simplified business processes:</b> a standard approach to the Measuring and Monitoring of Railways assets can simplify maintenance procedures</li> </ul>	

Impact type	Shift2Rail Impact	Contribution to KPIs (large spot=high contrib.)
<b>Degree of maturity of the envisaged solutions</b>	<p>The solutions developed within the TD3.7 will have two main different degree of maturity:</p> <ul style="list-style-type: none"> <li>• A TRL 4/5 if the technology used is a very innovative in the railways context;</li> <li>• A TRL 7/8 if the solution is an improvement of existing tools</li> </ul>	

### 3.5.7.5. Implementation of the work programme

#### Overall approach and methodology

In the following paragraphs an overall description of the contents of each task (the same for each subtask) is given. The RIMMS approach is to organize the delivery of the four defined tasks (Tracks, S&C, Signalling, Operations) in the same way, defining the following five-step process:

**Figure 80: TD37 Overall approach and methodology**

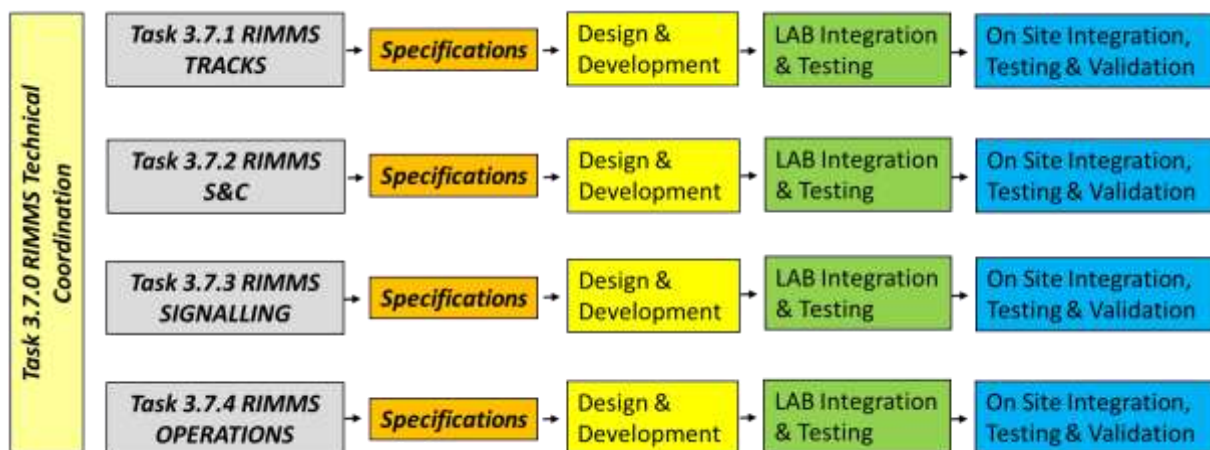

#### Clarification of input of Lighthouse project

Some of the results of the IN2RAIL Lighthouse Project can pave the road for the TD37 research activities. More in details the Shift2Rail Task 3.7.1, which has among its tasks also to develop a track geometry monitoring by in-service trains and a rail temperature stress monitoring, is strictly related to the IN2RAIL WP5. The WP5 will outline, for the above mentioned monitoring systems, the current data collection procedures and future needs and potentials to enhance such procedures, including current guidelines and constraints. The scope of the IN2RAIL WP5 is also to develop the two following monitoring concepts:

- *Track geometry monitoring by in-service trains:* The main objective of this task is to measure and assess track geometry by exploiting a small percentage of the entire fleet of commercial trains equipped with very simple on board instruments focusing on a more efficient evaluation of track



geometry. In S2R the target will be expanded to predict future track deterioration from measured data. (From IN2RAIL TRL5 to S2R TRL7);

- *Rail Temperature stress monitoring*: The task aims to decrease existing drawbacks by introducing a technique based on current measurement technology that may provide continuous monitoring of stress free temperatures with significant less traffic disruptions and need for workforce in track. The concept and the models which will be identified in In2RAIL (TRL3) will pave the road for the S2R research activities and for the development of the rail temperature stress monitoring system (TRL7);

**High Level Task Breakdown**

Task	Task Name	Task Description	Lighthouse Project Contribution (% / Budget €m)
<b>Task 3.7.1</b>	<b>RIMMS Tracks</b>	<ul style="list-style-type: none"> <li>• Develop proof-of-concepts and the feasibility validation of the following systems               <ul style="list-style-type: none"> <li>○ Track geometry and Track wear</li> <li>○ Rail temperature stress monitoring</li> <li>○ Environmental satellite/drone monitoring</li> </ul> </li> </ul>	
<b>Task 3.7.2</b>	<b>RIMMS Switches and Crossings (S&amp;C)</b>	<ul style="list-style-type: none"> <li>• Specification phase will be focused on a state of the art analysis (linked to TD 3.1 but also to other industrial sectors) and on the identification of the of key parameters to be monitored which affects the S&amp;C performances</li> <li>• Develop remote &amp; embedded sensors and new methods to gather status data from Switches for all critical S&amp;C failure modes</li> <li>• Develop switch geometry measurement techniques under axle loads combined with other NDT methods (e.g. automatic video analysis)</li> </ul>	
<b>Task 3.7.3</b>	<b>RIMMS Signalling</b>	<ul style="list-style-type: none"> <li>• Develop proof-of-concepts and the feasibility validation of automated system health real-time checks of critical signalling components</li> <li>• Provide to the Intelligent Asset Maintenance (I2M) the data through:               <ul style="list-style-type: none"> <li>○ A standardized gathering of diagnostic information from the Signalling and Telecomm components;</li> <li>○ Monitoring devices with the aim of verifying (from an external point of view) signalling devices (e.g. cameras to check the status of the signals);</li> <li>○ Additional non-invasive systems for the monitoring of the environmental variables/conditions that may adversely impact on the signalling system or on the overall railway availability.</li> </ul> </li> </ul>	

Task	Task Name	Task Description	Lighthouse Project Contribution (% / Budget €m)
Task 3.7.4	RIMMS Operations	<ul style="list-style-type: none"> <li>• Specification phase will outline the current data collection procedures and future needs and potentials to enhance such procedures relating to: <ul style="list-style-type: none"> <li>○ Pantograph Monitoring systems;</li> <li>○ Rolling stock 3D profile measurements;</li> <li>○ Innovative measurement of train load and wheel defects (flatness and other defects);</li> <li>○ Alternative rolling stock identifications systems.</li> </ul> </li> <li>• To integrate advanced measurement technologies in order to monitor the rolling stocks</li> </ul>	

### 3.5.7.6. Planning and budget

#### TD3.7 Gantt Chart

TD3.7 - RIMMS DEMONSTRATOR		2015				2016				2017				2018				2019				2020				2021				2022				2023				2024			
Task	Description	Q1	Q2	Q3	Q4	Q1	Q2	Q3	Q4	Q1	Q2	Q3	Q4	Q1	Q2	Q3	Q4	Q1	Q2	Q3	Q4	Q1	Q2	Q3	Q4	Q1	Q2	Q3	Q4	Q1	Q2	Q3	Q4	Q1	Q2	Q3	Q4				
3.7.1	RIMMS Track geometry																																								
3.7.2	RIMMS S&C																																								
3.7.3	RIMMS Signalling																																								
3.7.4	RIMMS operation																																								

#### TD3.7 Budget

The estimated budget for the TD is around 20.1M€.

### 3.5.8. TD3.8: Intelligent Asset Management Strategies Demonstrator (IAMS)

#### 3.5.8.1. Concept and objectives of the IAMS Demonstrator

##### Context

TD 3.8 IAMS forms together with TD 3.6 and TD3.7 the Intelligent Asset Management Pillar. This pillar is a driver – or a way – to make asset management according to ISO 55000 possible in the railway sector. The Intelligent Asset Management Pillar is an accelerator and driving force giving practical guidance for the implementation of a holistic asset management framework, together with other standards, best practices and guidelines, such as:

- Dependability and maintenance (EN 13306) and related topics, e.g. RAMS in railway applications (EN 50126), Reliability Centred Maintenance (IEC 60300-3-11)
- Risk management, e.g. ISO 31000 and IEC/FDIS 31010 (Risk assessment techniques)
- Whole-system maintenance planning and decision support, following principles for Predictive Maintenance, Condition- and Risk-based Maintenance

**Figure 81: Intelligent Maintenance 2.0**

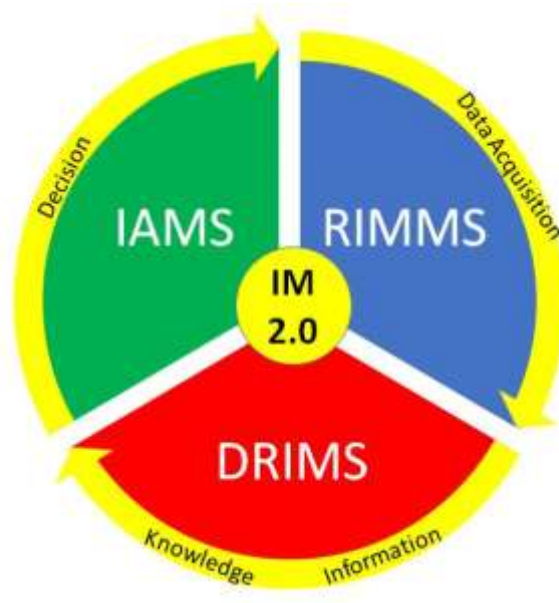

The foundations for this approach are laid in the Shift2Rail lighthouse project 'In2Rail'. The Asset Management framework will ensure a mutual understanding amongst all stakeholders in the value chain. Stakeholders in the value chain may differ in various countries and/or rail infrastructure operation.

**Figure 82: Context of Asset Management Framework**

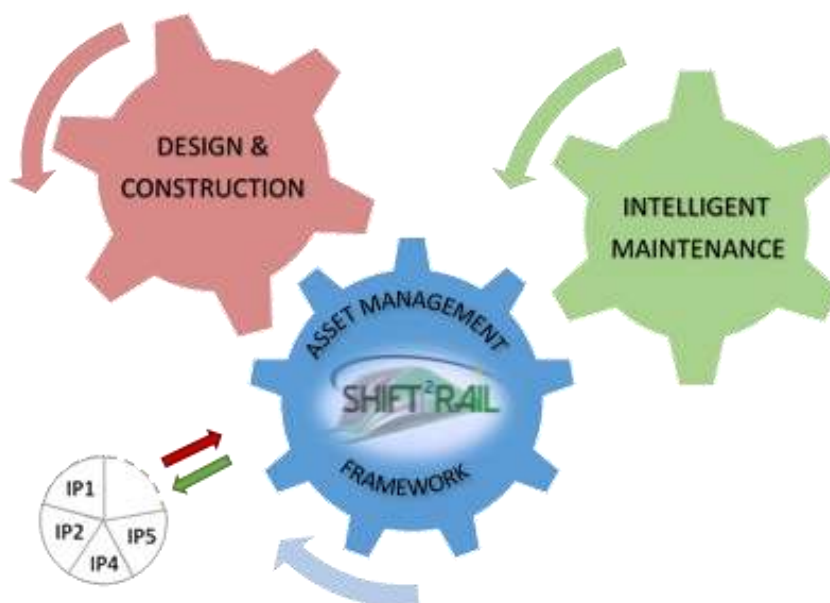

Figure above illustrates the context of the Asset Management framework, which links Intelligent Maintenance pillar with new solutions for design and construction and – as a whole-system approach – with other IPs.

#### **Definition and justification of objectives**

IAMS (Intelligent Asset Management Strategies) focuses on the definition of concepts for maintenance planning and decision support; implementation of risk- and condition-based maintenance strategies; decision support tools and system architectures for maintenance management, resource planning and deployment (including skilled staff, plant and possessions) and for LCC based maintenance or system improvement including state, age of asset and root causes for maintenance – supported by DRIMS. A second stream of technical objectives is related to new and advanced working methods, tools and equipment and logistics solutions, supporting the LEAN execution of intelligent maintenance processes.

Objectives	Result	Deliverable
Develop and test risk-based Asset Management (AM) approach that includes combination of RAM4S and LCC	Decision criteria based on risk, RAM4S and LCC for selected asset types. Adapted methodologies and tools for railway applications, e.g. RCM and FMECA for both systems and structures	A demonstrator of the toolbox for the risk-based AM including a combination of RAM4S and LCC.
Develop and test approach for linking Enterprise Risk Management (ERP) and related business objectives with risk-based AM and related RAM4S objectives	Decision criteria related to business objectives and deployed/linked to risk, RAM4S and LCC on asset level for selection and prioritisation of different asset types and related maintenance and renewal	A demonstrator of the toolbox linking ERP with risk-based AM and related RAM4S objectives.
Develop and test approach for integrated decisions of RAM4S for AM.	Conceptual model built for integrated decision making	A demonstrator of the toolbox for integrated decisions of RAM4S for AM
Develop and test approach for harmonising all identified operational and maintenance risks and asset's LCC for decision purposes	Criteria established for asset's LCC decision making under different scenarios incorporating the all risk factors.	A demonstrator of the toolbox for combining risk and LCC for decision purposes.
Develop and test new automated and smart working tools, methods and procedures for LEAN execution	Prototypes for machines, tools and working methods	A demonstrator for LEAN maintenance execution

The proposed Intelligent Maintenance solutions jointly offered by TD3.6, TD3.7 and TD3.8 represent a valid solution to achieve the following objectives: the reduction, more control and the accountability of maintenance costs; the increase of capacity due to improved integral performance of infrastructures; the increase and accountability to prove both passengers and workers safety due to a safer and better maintenance procedures; the reduction of noise and vibration due to a better maintenance approach. It is therefore possible to summarise the KPIs related to Intelligent Maintenance as follows:

KPI	Target for 2030	Target for 2050
Reduction of costs	30%	50%
Increase of capacity	20%	50%
Increase of safety	>20% Reduction of accidents and fatalities due to internal system failures	50%
Reduction of noise	minus 5 dB	minus 10 dB





### **Alignment to S2R Strategic Master Plan**

TD3.8 directly relates with the Intelligent System Maintenance research of the Master Plan. Since this research area is all about data, it is obvious that there is a strong interaction between TD3.6, TD3.7 and TD3.8. The perspective of the three TDs differs:

- TD3.7 RIMMS focuses on asset status data collection (measuring and monitoring) and processing and data aggregation producing data and/or information on the measured/monitored status of assets
- TD3.6 DRIMS focuses on interfaces with external systems; maintenance-related data management and data mining and data analytics; asset degradation modelling covering both degradation modelling driven by data and domain knowledge and the enhancement of existing models using data/new insights.
- TD3.8 IAMS concentrates on decision making (based also but not only on TD3.6 input); validation and implementation of degradation models based on the combination of traditional and data driven degradation models and embedding them in the operational maintenance process based upon domain knowledge; system modelling; strategies & human decision support.

In particular, the interaction between TD3.6 and TD3.8 can be both in the 'Push and Pull' mode: TD3.6 generates asynchronous information (push) when data pattern diverge from expected behaviour; TD3.8 either pulls synchronously information (at a given rate) from TD3.6 to update decisions or asks to perform more statistical analysis in certain situations, with specific parameters and data sets.

### ***3.5.8.2. Technical ambition of the IAMS Demonstrator***

#### **Ambition**

The current situation of railway maintenance is characterised as follows:

- The majority of monitoring and measuring systems are designed as independent tools thus making difficult the fusion of information and its integration in the maintenance process.
- A huge number of individual information systems are currently available in the EU railways, each of them dealing with individual and isolated areas of the maintenance process thus not exploiting the potentiality of big data analysis.
- Research and innovation results are showing that maintenance performances are strictly linked to many heterogeneous parameters, most of them not yet taken into account in the maintenance process.
- Typically applied maintenance is still periodic preventive maintenance based on good practices established a long time ago, simply integrated by targeted interventions when faults appear.
- Stakeholders' environment is becoming more and more and complex due to the increasing amount of parties – often with conflicting priorities – involved in infrastructure operation and maintenance.



### **Market Uptake**

After the completion of the R&D activities, market uptake of the developed solutions and technologies will be ensured by the following means:

- Demonstration will take place in a real operational environment to give acceptance and clearly show benefits.
- The developed solutions and technologies will be a major step forward towards existing ones, in particular the whole system approach provides opportunities never possible before.
- The solutions will be divided in orderly defined stages to be used stepwise or in blocks.
- Supporting activities for standardisation of solutions and their implementation will allow the creation of a more transparent, competitive market for service providers and contractors.
- Due to the close collaboration in this TD between asset owners, infrastructure managers, maintenance service providers and contractors it will be possible to combine expertise and knowledge about practically effective and marketable solutions.

### **Technical ambition**

It is evident that a quantum step in rail maintenance is required to make the infrastructure fit for the upcoming challenges and achieve ambitious targets.

IAMS will showcase substantial improvements of availability and reliability of railway infrastructure at the defined system platforms through adapted maintenance strategies, predictive, risk and condition based maintenance, and usage of decision support systems, new and advanced working methods, tools and equipment, maintenance plant and logistical solutions. IAMS will also support stakeholders in the decision to maintain or upgrade the track. This decision will be based on LCC and operational requirements like availability of track. Root Cause Analysis (RCAs) for single failures and related LCC analysis for removal of root causes will guide the decision.

The availability of a consistent and up-to-date rail asset register will enable the development and demonstration of new or highly improved maintenance strategies and supporting systems. Evaluating complex information from various sources, a reliable predicting model for asset degradation, multiple contingency scenarios and decision support systems allow for a substantial cost reduction and increased reliability, availability and quality of the infrastructure.

The complexity of intelligent maintenance covers the interests of those parties involved in the rail infrastructure system. For the infrastructure manager, intelligent maintenance results in long-term preservation of assets (expressed in RAMS requirements) at minimal life cycle cost, while for the operator, intelligent maintenance leads to an available and reliable traffic system. For the maintenance contractor, intelligent maintenance leads to effective and efficient maintenance processes, adequate working methods, and purpose fit logistics, tools and equipment.

State-of-the-art	Advance Beyond state of the art
Individual discrete maintenance management systems	Integrated maintenance management system
Reactive maintenance	Predictive maintenance
'Traditional' maintenance fail to take full advantage of enhanced components built-in the network	Advantages of new components are identified and are reflected in lower maintenance efforts
Infrastructure operators having isolated asset status information systems with customised decision support tools	Maintenance decision support tools with standardised interfaces enabling seamless integration of legacy asset status information systems, hence leading to increased interoperability
Maintenance decisions based mostly on static and pure geometric track quantities.	Reliable maintenance decisions based on asset assessment drawing from vehicle-track-environment interaction
'Preventive' maintenance procedures not fully reflecting technology advances and interactions between components involved (e.g. corrugation treatment based only on surface condition)	Predictive maintenance building on total system view of infrastructure and leveraging on condition based maintenance and life cycle cost assessment
Lack of real failure data to carry out reliability analysis (RAMS)	Databases of failure and historical maintenance actions which are the seed for RAMS analysis tools
Immature predictive concepts using asset specific degradation models neglecting uncertainties	Data drive approach. Probabilistic information on condition and risk assessment as base for decision making.
Specific-purpose tools with limited applicability	Generic decision support tool derived from a general-purpose framework, thus easily adaptable.
Lack of interaction with TMS	Integration in existing systems for logistics and traffic information.
Use of heuristics based on experience for decision support	Use of mathematical optimisation in intelligent planning tools.
Possession take a lot of time to secure before work and much hands on tool time	Advanced work methods. Equipment to automatically secured workspaces within seconds, fast working methods, intelligent machinery on in-service trains

### **Technical Limitations/Barriers**

The barriers to innovation in Shift2Rail include many themes and may be **[P]**olitical, **[Ec]**onomic, **[S]**ocietal, **[T]**echnological, **[L]**egislative, **[En]**vironmental in their nature. The bullet points below identify the barriers and obstacles which may limit the impact of TD 3.8 and reduce market uptake:

- Lack of long-term vision reduces uptake of innovative solutions **[P]**
- Restricted investment capital is a barrier to selecting optimised LCC option **[Ec]**
- Existing contractual agreements framework restrict uptake of new technology **[Ec]**
- Resistance to change due to culture & competence through 'patterning' (forming of fixed ways of behaving) **[S]**



- Current decision making sometimes based on subjectivity rather than actual data analysis **[S]**
- Current ways of working not consistent across Europe, increases difficulty in making a universal incremental change or step-change **[S]**
- Legacy systems in most of EU countries and lack of harmonisation are an obstacle for interoperability **[T]**
- European disparity in technological level **[T]**
- Restrictions on operational data across Europe, availability/confidentiality, as well as timing systems (synchronisation) for cross-country operations **[T]**
- Regulatory/legal barriers around introducing new products and techniques – i.e. national notified rules; national product acceptance processes; national standards; and specifications **[L]**
- Interfaces with other transport modes and other sectors i.e. energy interfaces with public grids including contractual conditions **[L]**
- Climatic variation across Europe affecting compatibility, interoperability, and standardisation **[En]**

The following major risks are foreseen specifically for this TD.

Nº	Risk description	Mitigation action proposed
1	The issue of developing a general Asset Management framework is a new challenge for the rail industry, different expectations on results could lead to a divergence of developments.	At the very beginning of the activities a common understanding of the objectives and work methodology has to be established, based on a long-term vision of the Asset Management framework to be developed. Strong coordination amongst participants is required.
2	The high diversity and disparity in current procedures in maintenance planning and execution could hinder the creation of a common framework which is widely accepted and applicable.	An agreement on the level of abstraction, at which standards, guidelines and best practices shall be applied, will be established. The involvement of a stakeholder group compiled of relevant parties will allow to first of all to identify disparities and monitor their resolution.
3	IAMS decision support tools and decision making procedures could get too general to be applied and loose practical relevance.	Involvement of potential end users into the specific implementation phases of the activities will help to find prototypical scenarios.
4	Lacking confidence for the adoption and implementation of novel frameworks related to Asset Management and maintenance could lower their impact.	To borrow success stories from more other industries with mature solutions, standardisation processes and their implementation (e.g. aviation, manufacturing, power plants).
5	Lacking interaction and coordination with relevant activities in other IPs and CCAs, in particular in IP2 related to the integration with Traffic Management, CCA work area on Smart Maintenance, could lead to diverging developments.	Early discussion about overlaps, synergies and needs for complementary activities between relevant participants, followed by periodical meetings between IP/CCA leaders to monitor the progress.
6	Restricted availability of data related to maintenance operations, failure modes and causes, planning procedures etc. could hinder some developments.	The level of investments and high level of participation of Railway Undertakings and Infrastructure Managers provides a sound basis for data availability.

### References to existing EU funded research projects

Potential synergies can be found with the following FP6, FP7 and H2020 EU-funded research projects:

Acronym (EC Reference)	Description of Project
<b>ACEM-Rail</b>	Algorithmic solutions for the mathematical optimisation of operational and tactical maintenance planning that are effective in terms of costs and resource utilisation, fulfil safety requirements, and guarantee a high level of service quality.
<b>AUTOMAIN</b> (GA 265722)	Research results on mechanised track maintenance and inspection (tamping and grinding); LEAN analysis of working methods and processes to reduce possession times; demonstration of advanced switch monitoring; decision support methodologies and algorithms for maintenance planning and scheduling; elaborated distinction between "inspection" and "monitoring"
<b>CAPACITY4RAIL</b> (GA 605650)	Research work on infrastructure, train dispatching and timetable planning and monitoring. Recommendations for Open-Source and Open-Interface for advanced railway monitoring applications
<b>D-RAIL</b> (GA 285162)	Cost efficient measures to reduce derailments
<b>INFRALERT</b>	Cloud-based information system to support and automate linear asset infrastructure management from measurement to maintenance, including expert toolkits for the assessment of asset condition, alert management, RAMS&LCC evaluation and smart decision support.
<b>IN2RAIL</b> (GA 635900)	Standardised approach to information management and dispatching system enabling an integrated Traffic Management System. Information and Communication Technology (ICT) environment supporting all transport operational systems with standardised interfaces and with a plug and play framework for TMS applications. Advanced asset information system with the ability to 'nowcast' and forecast network asset statuses with the associated uncertainties from heterogeneous data sources.
<b>INNOTRACK</b> (GA 31415)	Analysis of major track cost drivers to reduce maintenance costs for sub-structure, track, S&C including LCC and logistics aspects
<b>INTEGRAL</b> (GA 12526)	Proposed approaches and demonstrators for intelligent communication infrastructure, including information system architecture and semantic data structure
<b>MAINLINE</b> (GA 285121)	Life cycle assessment tool and findings regarding modern technologies for track, tunnels and bridges
<b>SUSTRAIL</b> (GA 265740)	Optimised track and substrate design and component selection to increase sustainable freight traffic as part of mixed traffic operations

### **3.5.8.3. Specific Demonstration activities and contribution to ITDs/SPDs**

#### Vision

In the Intelligent Maintenance Area of research, there will be two levels of demonstration:

- The first level will be the one focused on the TD objectives demonstration (TD3.8 DEMO);
- The second level will be an integration level (ITD) to demonstrate the overall Intelligent Asset Management concept (IAM ITD).

The *TD3.8-DEMO* will foresee the on field test and validation of the several technical innovations and solutions designed and developed during the project.

To be effective and demonstrate maximum impact from individual innovations and technologies, the scope of TD3.6, TD3.7 and TD3.8 will be harmonised. The scope of the TD3.8 DEMO will be closely related to the technologies from TD3.7 (monitoring and measuring) and all necessary information and knowledge (from TD3.6) to address and feed at best maintenance activities on mainly the assets tracks and S&C.

**Figure 83: Relationship of TD3.8 with other TDs**

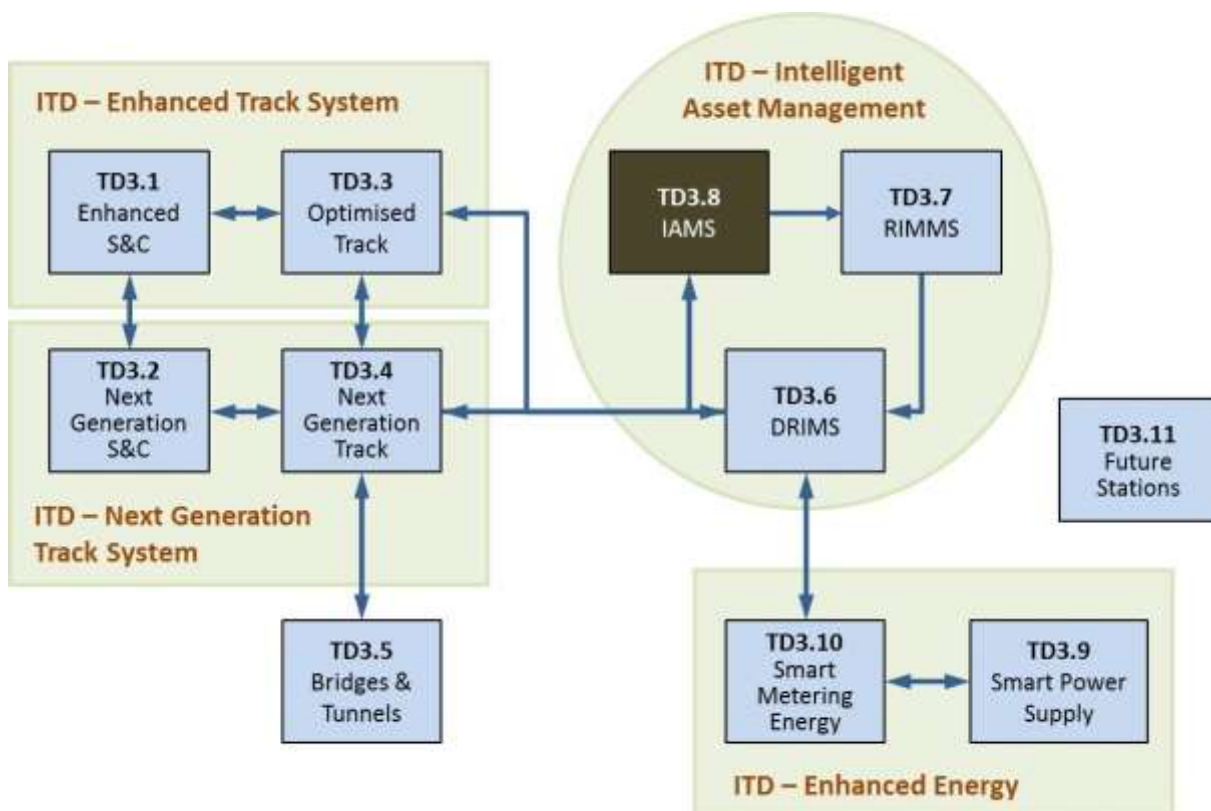

### **Approach**

The TD3.8 will perform 'physical' demo distributed both geographically and in terms of families of assets to be involved. To this end 4 main demonstrator areas have been defined (each of them is related to a specific task of the TD3.7 as described in the following paragraphs):

- Track geometry and Rail Thermal stress;
- Switches and Crossings (S&C);
- Signalling;
- Operations.

TD3.8 will get necessary technologies from TD3.7 (monitoring and measuring) and all necessary information and knowledge to address and feed at best maintenance activities on mainly the assets tracks and S&C.

The approach is that each development will be demonstrated at a low profile for an isolated demonstration and optimisation purposes. In a second step the individual solutions will be placed in a broader context with other innovations.

The ITD level will have to demonstrate the overall concept of Intelligent Maintenance: this requires the availability, in the same context, of demonstrators coming from the 3 TDs (components), and linked to the defined topic.

The ITD has to guarantee the demonstrability of the overall concept, which is the demonstration of the improvement of maintenance process and strategies (TD3.8) through knowledge extracted from information (TD3.6) coming from available data, measuring and monitoring systems (TD3.7)

**Figure 84: Relationship between demonstration activities**

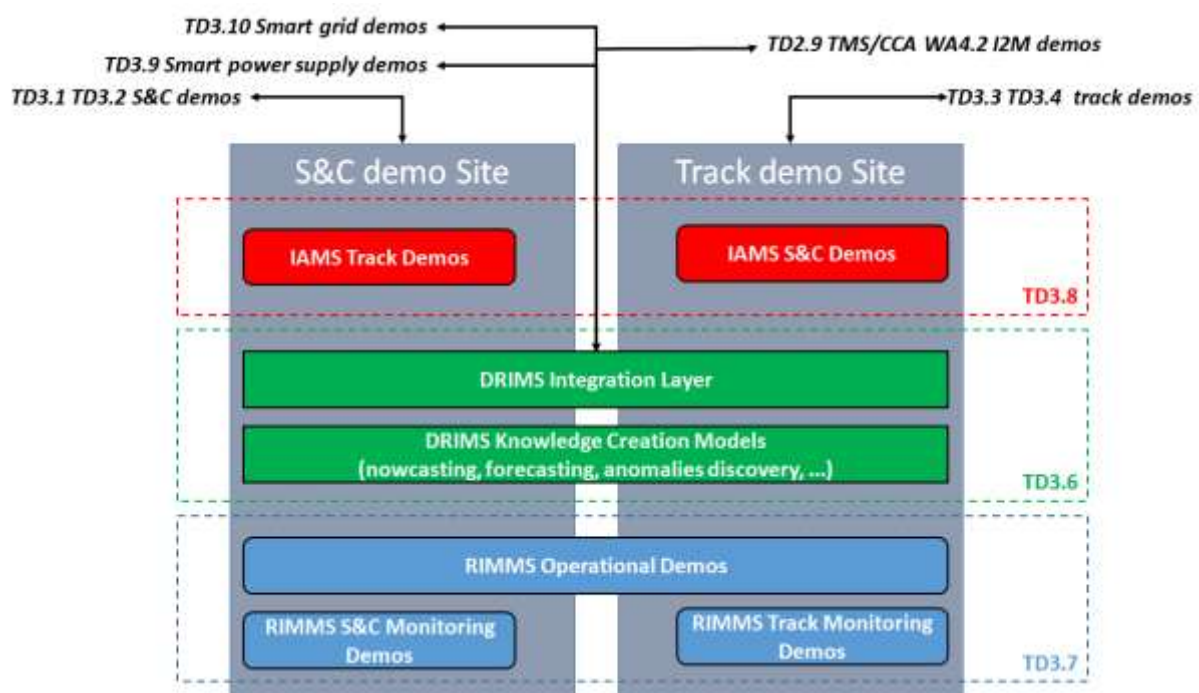

The IAM-ITD components must have the following characteristics:

- coherent data set;
- consistent maintenance processes and strategies to be improved;
- measuring and monitoring systems to the scope; and
- an overall standardized IT architecture and related interfaces to allow a proper seamless management of data, information and knowledge.





#### **3.5.8.4. Impact of the IAMS Demonstrator**











##### **Benefits**

A large proportion of the cost of the European Rail Infrastructure is for maintenance. Due to rising pressure of utilisation of railway infrastructure for passenger and freight transport; environmental and safety regulations, increasing maintenance requirements cannot be met without a substantial shift in maintenance strategies. This shift and tailor made maintenance approach can only be reached with the necessary tools for information management and decision support. A scalable framework for asset management systems, containing the static and dynamic data from all relevant components of the rail infrastructure will enable improved lifecycle management, efficient maintenance strategies and adequate operations planning which includes logistic preparation, deployment of staff, tools, equipment and plant and possessions.

The *benefits* of the application of IAMS come from its holistic, whole-system approach in combination with the new methodologies and data-driven concepts provided by TD3.6 and TD3.7. In other words: make new maintenance approaches happen in a practical way. The IAMS TD bridges theoretical processes about asset behaviour and degradation, asset management theories and individual maintenance strategies for specific sub-systems to the actual work outside in the operational process. The operational process is defined as the day to day maintenance and small and medium renewal work and how it is organised. Long term strategies are often hampered by the day to day process with its own dynamics and therefore the intention of the bigger picture sometimes is not followed through. By putting long term strategies in the context of the actual execution of the maintenance work in combination with other maintenance activities, instead of focussing on individual, simple (sub) systems, IAMS will look at it as a 'system of systems'.

Decision support tools and systems for maintenance planning as a result of the developments in TD3.8 will provide a long-term benefit to the Infrastructure Managers in fulfilling their tasks/activities according to Community Directives 91/440 and 2001/14, in particular for capacity calculation, allocation and enhancement of the infrastructure. Decision making processes will become more transparent, controllable and their results will be directly accessible by railway service providers and customers.

## Technical Impact

Impact type	Shift2Rail Impact	Contribution to KPIs (large spot=high contrib.)
<b>100% Capacity Increase</b>	Improved integral performance of railway infrastructure by combining maintenance with optimised operation.	
	Optimised working methods reduce the required down-time for maintenance activities.	
	Predictive maintenance planning reduces down-time required for inspection and due to unexpected failures.	
	Combined maintenance activities in a LEAN approach to minimise track possession.	
<b>50% Reduction in LCC</b>	Reduction of recurring operational costs for maintenance due to better planned maintenance activities taking into account cost and risks	
	Development of guidelines for the design of low-maintenance and maintenance-free infrastructure systems	
	Standard open interfaces promote the market entry of competitive IT solutions	
	Deployment of lean logistics and efficient work methods	
<b>50% Increase in Reliability and Punctuality</b>	Reliable asset status nowcasting and forecasting boost predictive maintenance and reduce unexpected maintenance interventions	
	Enhanced integration with Traffic Managements Systems leads to balanced and controlled interventions in between service and maintenance	

## Contribution to TSI and Standards

In a long-term vision, it is aimed for TD3.8 to contribute to the specification of new TSI requirements in the area of Asset Management. The generic frameworks for maintenance planning and execution to be developed, in accordance with the systems, tools, technologies and procedures derived, shall enable the establishment of European-wide applicable best practices, guidelines for implementation and standardisation approaches (e.g. based on ISO55000 for Asset Management and specific application guides in other industries). These contributions shall be aligned with the activities in TD3.6 and 3.7, as they together form the vision of Intelligent Maintenance 2.0 and affect the Asset Management process as a whole.

**Strategic Impact**

Impact type	Shift2Rail Impact	Contribution to KPIs (large spot=high contrib.)
<b>Support the competitiveness of the EU industry</b>	<ul style="list-style-type: none"> <li>• Global technological leadership supported by a combination of innovation and technical standards, setting an effective advantage for the European industry:               <ul style="list-style-type: none"> <li>○ Seamless migration of an innovative maintenance decision making concept into daily practice.</li> <li>○ Establishing a standardisation process in the area of infrastructure measuring, monitoring and maintenance.</li> <li>○ Design and implementation of an ISO 55000 compliant data-driven concept for intelligent maintenance: The Asset Management Framework.</li> </ul> </li> </ul>	●
	<ul style="list-style-type: none"> <li>• Increase attractiveness and competitiveness:               <ul style="list-style-type: none"> <li>○ Increase of operational reliability (less service disruptions) through a progressive migration from corrective maintenance to predictive maintenance, which is less resource and time consuming and has less impact in train operation.</li> <li>○ Reduce system cost in the short term, by 40% due to better planned maintenance, the deployment of lean logistics and efficient execution procedures, and even more in the long term thanks to the low-maintenance oriented design derived from the Asset Management Framework engine.</li> <li>○ Increase infrastructure capacity by at least 20% because of the reduction of downtimes due to unexpected failures and the optimisation of track possession for maintenance activities.</li> </ul> </li> </ul>	●
<b>Compliance with EU objectives</b>	<ul style="list-style-type: none"> <li>• Promotion of modal shift: A big impact brought by the implementation of these new technologies .....</li> <li>• Achieve single European Rail Area (SERA) due to a common understanding making long term decisions based on an ISO 55000 framework, monitoring the effect European wide of new technologies enabling further optimisation faster and for the whole of the European rail sector.</li> <li>• Enhanced interoperability and simplified business process through the development of a general framework for Asset Management, defining new and contributing to existing standards across Europe.</li> </ul>	●
<b>Degree of maturity of the envisaged solutions</b>	Currently most of the proposed technologies are in TRL 2-4 (Formulation and experimental proof of technology concepts). At the end of Shif2Rail it is expected that the successful concepts are brought to TRL 6 or 7.	●

### 3.5.8.5. Implementation of the work programme

#### Overall approach and methodology

The idea behind the **approach** of IAMS is to acquire data in a holistic manner, meaning that it will be able to use different systems' data sources (both from rolling stock and infrastructure) to get new information for the decision making processes. This information will feed the Intelligent System Maintenance solutions via a standardised and open interface layer, assuring the extendibility, interoperability and adaptability of the concept and systems developed in future implementation phases. The actual data processing within the IAMS approach is done to gather knowledge on asset behaviour (RAM4S, LCC, alerts related to asset condition) as well as to derive decisions for planning of maintenance activities, applying innovative principles. As a by-product, the maintenance expert knowledge will allow tackling with upgrading of legacy assets and design of new generation infrastructure components from a performance and life-cycle cost perspective. On-site planning and management of maintenance works, considering logistics aspects and making use of novel machinery, tools and procedures, complete the holistic approach of IAMS. The following figure illustrates these elements and their relation.

**Figure 85: IAMS approach**

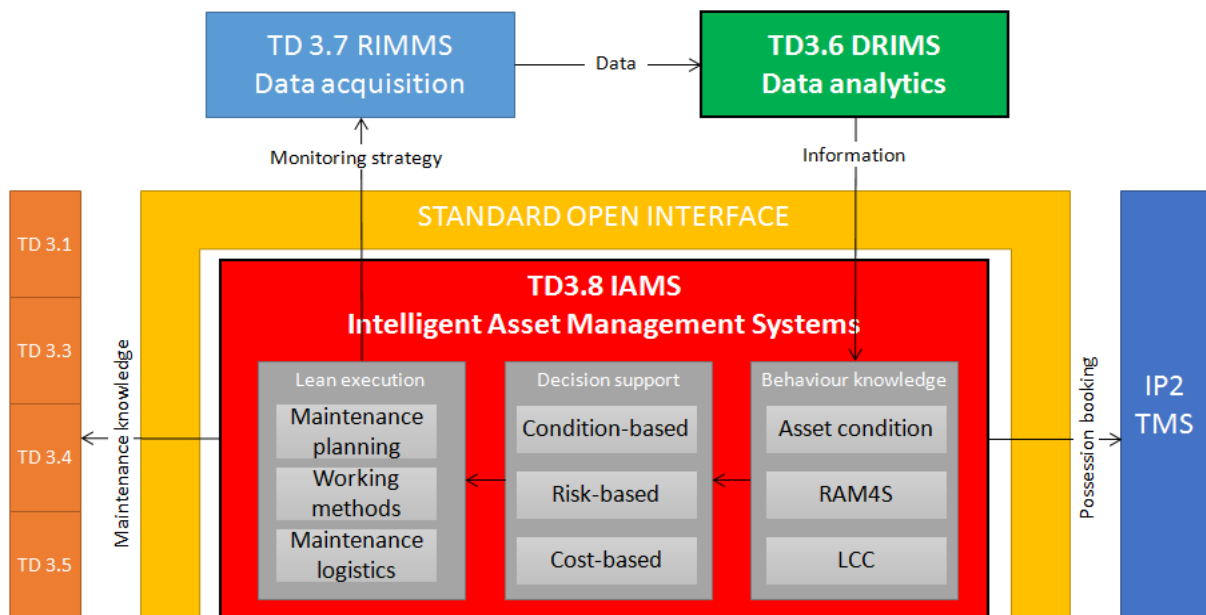

Establishment of appropriate information logistics is a great challenge when dealing with maintenance since necessary information is often hidden among vast quantities of data, stored for other purposes, at different places and stake holders, in different formats, and generated throughout the whole life cycle of a system. Through innovation and technology transfer from other sectors (e.g. aeronautics) the following developments will be made:

- Definition of system-oriented, service oriented, process-oriented and lifecycle oriented Intelligent Maintenance solutions;

- An identification of critical information and information support requirements for all stakeholders including customers and service providers while implementing Intelligent Maintenance;
- An identification of ICT-related methodologies and technologies suitable to fulfil the information support requirements of stake holders and service providers;
- An approach for development and provision of ICT-based information support solutions that satisfy the requirements of stakeholders and service providers.

The **methodology** applied involves techniques from Artificial Intelligence, optimisation theory and stochastic to cope with the complex challenges in maintenance planning and asset behaviour analysis. Various engineering and rail system technologists expertise is needed to enable the development of lean execution methods, tools and procedures.

**Figure 86: Scope and methodologies in IAMS**

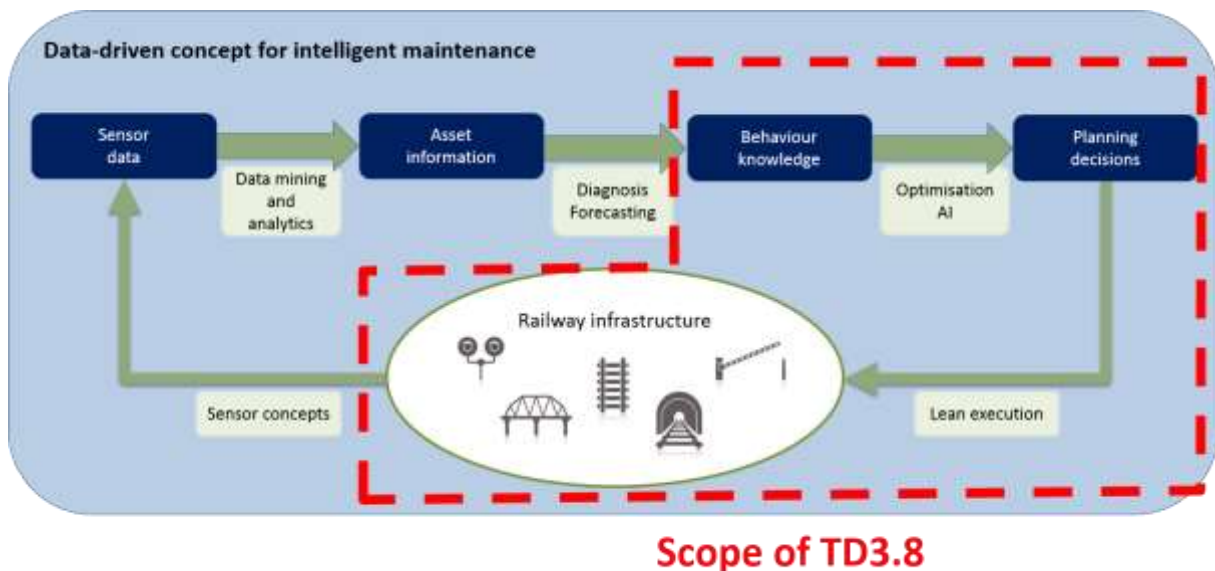

**High Level Task Breakdown**

Task	Task Name	Task Description	Lighthouse Project Contribution (%/ Budget)
<b>Task 3.8.1</b>	<b>State of Play</b>	<ul style="list-style-type: none"> <li>• Develop existing knowledge on maintenance management using Shift2Rail member knowledge together with previous EU projects, to identify best practice concepts</li> <li>• Complete knowledge transfer from existing EU and international research projects.</li> <li>• Collate existing EU knowledge and experience relating to relevant maintenance strategies and work methods.</li> <li>• Experience/best practices/standards also from other sectors (manufacturing, road, ...)</li> </ul>	In2Rail
<b>Task 3.8.2</b>	<b>Risk and Asset Management based strategy</b>	<ul style="list-style-type: none"> <li>• Produce a strategy for system maintenance focused on Risk Management, Asset Management (RAMS and RCM)</li> <li>• Develop the asset management framework which will embed the Intelligent System Maintenance</li> <li>• Identification and detailed specification of IAMS principles: holistic, predictive, risk-based, condition- and use-based, reliability-centred, evidence-based, opportunistic, nested/adaptive, integrative</li> <li>• Description of contents: flow of information, interaction of components (like RAM4S, LCC, nowcasting/forecasting, alert management, planning levels, ...), workflow of maintenance planning</li> <li>• Drafting guidelines and best practices for maintenance stakeholders (IMs/RUs/contractors/service providers/outsourcing of maintenance service)</li> <li>• Drafting guidelines and specifications for developers of tools/systems/models</li> <li>• Stimulating standardisation approach</li> <li>• Transferability of strategy concepts to rolling stock maintenance</li> </ul>	In2Rail

Task	Task Name	Task Description	Lighthouse Project Contribution (%/ Budget)
Task 3.8.3	<b>Decision Support Tools and Systems</b>	<ul style="list-style-type: none"> <li>Investigate and develop decision support tools and systems for maintenance planning and work preparation, possession planning, maintenance plant, logistical solutions.</li> <li>Specification and implementation of a high-level ICT systems architecture</li> <li>Specification and implementation of interfaces following open standards</li> <li>Functional design and prototypical development of relevant tools: strategic planning (considering long-term strategies), tactical planning (considering e.g. possessions), operational planning (considering e.g. logistics, work site/plan management, TMS), RAM4S analysis, alert generation and management, Life Cycle models (incl. maintenance, failure modes, inspection) (transferability of planning concepts to rolling stock maintenance)</li> <li>Implementation of subsystems, databases (following ICT privacy/security/reliability aspects defined in other TDs/IPs)</li> </ul>	
Task 3.8.4	<b>Clever and Smart Maintenance</b>	<ul style="list-style-type: none"> <li>Deliver solutions for clever and smart maintenance in between train operation with optimum use of infrastructure capacity, meaning effective use of possessions, dynamic use of complex (mobile) work sites, efficient use of machines</li> <li>Use and development of tools and equipment for lean maintenance under highest safety regulations in Europe</li> <li>Look for technical solutions to speed up the process of activating possessions.</li> </ul>	
Task 3.8.5	<b>Work methods and (automated) tools</b>	<ul style="list-style-type: none"> <li>Deliver work methods and (automated) tools to use rail operation free time/space for short maintenance activities (plug-and-play, hit-and-run).</li> <li>Further mechanisation would lead to less people in track (enhanced safety) and a higher level of accuracy and accountability of the tasks executed.</li> <li>Well educated and trained staff is an essential element to make intelligent maintenance work.</li> <li>Logistics solutions including possession management and work site management systems.</li> </ul>	
Task 3.8.6	<b>Identification of the demonstrators</b>	<ul style="list-style-type: none"> <li>Identifying the demonstrators for TD3.8 and compare the demonstrators under TD3.8, TD3.6 DRIMMS, and TD3.7 RIMMS to identify commonality and develop an integrated test plan.</li> <li>Select partners for developing a model for data exchanges and interdependencies for all the TDs in relation to TD3.8.</li> </ul>	

Task	Task Name	Task Description	Lighthouse Project Contribution (%/ Budget)
<b>Task 3.8.7</b>	<b>Demonstrate the results for the system platforms high speed lines and urban/suburban lines</b>	<ul style="list-style-type: none"> <li>• Develop a smart model for data capturing and converting that in to useful information being used for performance reporting.</li> <li>• Production of a test plan including different scenarios for assessing and analysing the demonstrators.</li> </ul>	
<b>Task 3.8.8</b>	<b>Performance Assessment</b>	<ul style="list-style-type: none"> <li>• Gathering of performance for assessing the next generation of intelligent maintenance, including technical and economic aspects quantification</li> <li>• Develop a model mathematically based on the pre-defined mechanisms for deriving the key performance indicators.</li> <li>• Performances outputs and compare it with the historical maintenance performance data to highlight the pros and cons.</li> </ul>	



**3.5.8.6. Planning and budget**

**TD3.8 Gantt Chart**

TD3.8 - IAMS DEMONSTRATOR		2015				2016				2017				2018				2019				2020				2021				2022				2023				2024							
Task	Description	Q1	Q2	Q3	Q4	Q1	Q2	Q3	Q4	Q1	Q2	Q3	Q4	Q1	Q2	Q3	Q4	Q1	Q2	Q3	Q4	Q1	Q2	Q3	Q4	Q1	Q2	Q3	Q4	Q1	Q2	Q3	Q4	Q1	Q2	Q3	Q4	Q1	Q2	Q3	Q4				
3.8.1	State of play																																												
3.8.2	Risk and Asset Management based strategy																																												
3.8.3	Decision Support Tools and Systems																																												
3.8.4	Clever and Smart Maintenance																																												
3.8.5	Work methods and (automated) tools																																												
3.8.6	Identification of the demonstrators																																												
3.8.7a	High speed line demonstrator																																												
3.8.7b	Urban/suburban line demonstrator																																												
3.8.8	Performance Assessment																																												

**TD3.8 Budget**

The estimated budget for the TD is around 17M €.

### 3.5.9. TD3.9: Smart Power Supply Demonstrator

#### 3.5.9.1. Concept and objectives of the Smart Power Supply Demonstrator

##### Context

The global objective of a railway smart grid is to develop the actual unique railway power grid in an overall interconnected and communicating system (Figure 87). This new railway network integrates smart metering, innovative power electronic components, energy and economic management system, energy storage system and local and/or environmentally friendly power sources. This new concept leads to improved and optimized train traffic, energy costs, energy supply security for the railway system, energy efficiency (in term of availability) and environmental impact thereof.

In parallel it will allow for optimised solutions for the elements used in this network through optimising investment, operation costs and maintenance.

Many of the topics shown in Figure 87 are equivalent with standard power grid solutions. So the developments planned in Shift2Rail refer to unique railway specific tasks inside this network and to railway specific application of technologies used in other fields of applications, like standard power grids. TD3.9 ‘Smart Power supply’ covers the range of applications marked by the dotted box showed in Figure 87.

**Figure 87: Schematic view of rail traction power supply in a smart power environment**

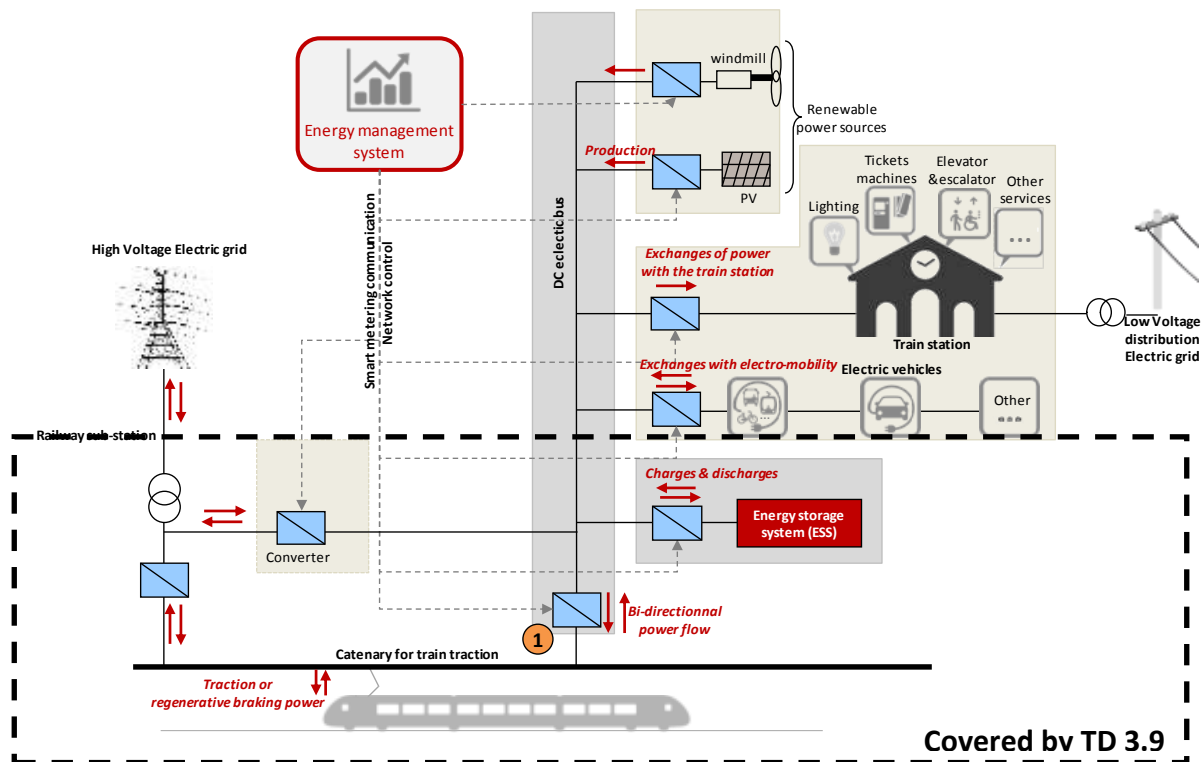



### **Definition and justification of objectives**

**TD3.9 ‘Smart Power supply’ cannot assure all these technical issues and challenges and** is aimed at defining and demonstrating solutions to optimize the Traction power supply systems of AC electrified railways. Solutions for DC are mainly investigated in former EU-funded projects and actual ‘under-test’ operations. However, the connection of the studied architecture with the different components available Energy Storage System, Renewable energy and rail station is not excluded. For this, existing elements available from other technologies can be integrated in the planned demonstrators.

To achieve a solution for all requests within TD3.9 the following functionalities will be implemented in the rail power system:

Objectives	Result	Deliverable
Development of innovative control and protection concepts as a basis for parallel operation of substations using information from running trains and feeding grid	A prototype demonstration of innovative control and protection concepts implemented in an AC-traction power substation.	Control and protection system: -Technical reports; - Interface specification - HW/SW solutions.
Development of control concepts and substation integration for load balancing on 3-phase grid at single substations in 50 Hz rail power systems	A system prototype demonstration of 50Hz traction substation controlling reactive power and balancing load between the phases of the feeding 3-phase grid.	Control procedures and integration rules for implementation of FACTS-equipment in 50 Hz-traction substations.
Basic functionality for controlling the rail power supply network integrated with train operation and 3-phase grid status.	A functional specification and interface definition and specification of control procedures to implement a prototype demonstrator in a second step.	Control procedures for parallel operation of substations considering rail operation and feeding grid status

Implementation of TD3.9 will reduce the installed power per line length and will also reduce the transfer losses for energy in an important level.

### **Alignment with Shift2Rail Strategic Master Plan**

The specific benefits will have a major impact in the Shift<sup>2</sup>Rail objectives. The strategic outcomes of TD3.9 will be in line with the targets of the Master Plan as follows:

System costs will be reduced by:

- Minimizing investment cost
- Reduced energy losses for minimized life-cycle cost

Enhanced Interoperability will be achieved by reducing restrictions for operation.

Leadership on the global market will be ensured by use of highly efficient, barrier breaking technologies.



Attractiveness of the Rail system will increase by more sustainable use of energy for rail transportation and facilitate shift from fossil fuel based transportation to electrical energy based transportation.

### **3.5.9.2. Technical ambition of the Smart Power Supply Demonstrator**

#### **Ambition**

The actual technical status for AC Rail power supply systems with standard frequency is as follows:

- Transformers in substations are connected with different phases;
- Phase separations requiring switch-off for the trains every 20-40 km;
- Single side feeding of feeding sections;
- Complete load for the total feeding section allocated to one feeding point;
- Automatic Control of load flow and protection only for one substation; and
- For higher single phase load, connection to feeding grid with higher capacity (typically higher voltage).

AC rail power supply systems are single phase systems with 50 Hz standard frequency or special frequency of 16.7 Hz. Innovative control and protection concepts will allow for higher capacities with reduced investment and for optimum operation with minimized costs.

For a 50 Hz rail power supply system, a direct single phase connection with the feeding grid via transformers is used. This limits the capacity by permitted values for unbalancing the three phase system and restricts the feeding schemes on railway lines.

Innovative application and control of Flexible-AC-Transmission-System (FACTS) equipment for railway traction systems will lead to the following benefits:

- Minimized energy losses,
- Optimal dimensioning for rational fit between installed and used power to reduce investment or increase line capacity for existing lines,
- Parallel connection of substations allow for elimination of phase separations on line and will reduce restrictions to operation for better Interoperability and reduce maintenance costs
- Feeding from weaker 3-phase-grids with lower voltage for minimized investment,
- Optimum control of the load between the connection points depending on supply and demand of the railway network and feeding public grids to reduce load peaks for low energy costs and optimal dimensioning for feeding grid,
- Offer services to the grid operator like frequency and voltage support, reactive power compensation, reduction the phase unbalance, etc.,



- Railway services: maintain a good supply of catenaries all along the track to increase capacity line, gap section removal, etc., and
- Minimize the energetic invoice: feeding from weaker 3-phase-grids with lower voltage to minimize electric grid connection cost and subscription, the energy purchase and disparity between actual and predicted consumption payment.

To achieve the planned benefits with a solution that meets all requests the following functions will be implemented in the rail power system:

- Control and protection systems allowing parallel feeding including low distribution control for different target modes, defined by the needs and requirements from the power supply network (dispatch 3 phase load, reactive power, minimise losses),
- Intelligent control units to balance the single phase railway load to the three phase public grid, and
- Intelligent load control including load anticipating systems for load dispatching between feeding sections.

The technical task is the investigation and definition of operation and control procedures and rules for dimensioning the elements to achieve the functions for the planned innovative system, based on existing hardware solutions. The balancing hardware can be controlled as a single element. This will allow for usability in existing networks and give an implementation path. Design rules and control procedures allow for application in different networks.

Additional effects and possibilities for load management, in collaboration with the power grid operator, will be achieved by implementation of a set of power control hardware. For this step, procedures for load management based on input from the rail power supply and from the feeding grid will be implemented. Parallel operation will be solved by defining use concepts to demonstrate in a further project demonstrator.

The main technologies are the control of single and connected controllable power supply hardware to control simple and complex networks of power supply systems for energy optimisation purposes, based on Railway load cases for parameters and behaviour of feeding grids.

Today's automation and protection schemes are based on conventional wired sensors and actors. They have to be fitted to the specific application each time and have no or very little monitoring capabilities. The development of smart components and interfaces enables an innovative traction substation design to fulfil the needs of the future electric railway grid. The use of modern communication technology increases the EMC, largely reduces the frequency dependency and increases the standardisation and interoperability allowing an application for every partner in the single European railway area. The work until TRL 3 is done in the Horizon 2020 and Shift2Rail lighthouse project In2Rail WP10. The resulting schemes will be used and required for the balancing and load management implementation.



The Smart AC Rail power supply system interfaces inside S2R project with:

- **IP2:** Control procedures will be influenced by Traffic Management. Integration in TMS and MMS systems will be implemented with the demonstrator.
- **TD3.8:** The active equipment and the controls allow for using load/stress characteristics for scheduling maintenance for the elements.
- **TD3.10:** The results of 'Smart Metering' demonstrator will be used for the control and protection concepts

### **Technical Limitations/Barriers**

Barriers and obstacles which may limit the impact of TD3.9 and reduce market uptake are:

- Resistance to change due to culture and competence through 'patterning' forming of fixed ways of behaving,
- Current ways of working not consistent across Europe, increases difficulty in making a universal incremental change or step-change,
- Implementation at existing lines requires compatibility; This may require additional adaption,
- Interaction with 3-phase grid requires modification of contracts; Existing long term contracts or national regulations may restrict rapid setup, and
- New Equipment and procedures are actually not covered by consistent regulations across Europe; Fast setup requires acceptance of assessment rules defined in Task 3.9.4.

The following major risks are foreseen for the TD.

Nº	Risk description	Mitigation action proposed
1	People from academia/external SMEs not familiar with the dangers present in the railway system	Working in the railway system without proper training/qualifications is not accepted



### References to existing EU funded research projects

The project will be fed by inputs from the following existing FP6 and FP7 RTD projects:

Acronym (EC Reference)	Description of Project
<b>RAILENERGY</b> (GA 31458)	The overall objective of Railenergy is to cut the energy consumption within an optimised railway system thus contributing to a reduction in the life cycle costs of railway operation and of CO2 emissions per seat/kilometre or tonne/kilometre.
<b>MERLIN</b> (GA 314125)	Optimisation concepts and proposals for minimising energy demand
<b>IN2RAIL</b> (GA 635900)	IN2RAIL is to set the foundations for a resilient, consistent, cost-efficient, high capacity European network by delivering important building blocks that unlock the innovation potential that exists in Shift2Rail

The implementation of technical demonstrators and the achievement of the planned results requires for usable configurations in existing networks to implement the additional elements developed for the demonstrators. The basic power hardware for the demonstration (substation switchgears, transformers, ...) is not included in the budgets for the technical demonstrator.

The demonstration planned under TD 3.9 covers optimisations for the Rail traction power supply itself and also optimisations in the grid environment with the public feeding grid. A clarification for this interfaces is an integral part of work inside IN2Rail investigations. Implementation in demonstrators requires participation of power grid companies, are actual not covered by the members of Shift2Rail, in open calls.

### Market uptake

By the end of the proposed work, all the principal elements required for rapid market uptake will have been achieved. These include:

- Demonstration of technologies in a real operation environment that provide objective measures and hence give credibility and clearly show benefits. This covers especially the requirements of all relevant Stakeholders.
- Clear and easy to use application and implementation rules for the new systems and covered products
- Solutions designed to be simple to operate, easy to maintain, completely interoperable and full inter-compatibility, allowing for effective and efficient supplier competition.
- Data interfaces usable for data collection under the tasks developed under TD 3.10 and for interfacing with existing data collection and interpretation systems

### 3.5.9.3. Specific Demonstration activities and contribution to ITDs/SPDs

#### Vision

The demonstration of complex functionalities in railway power supply environment requires integration into existing grids. During the development phase until TRL 7 a TD segmentation is done to shorten the time needed to complete the overall result.

**Figure 88: Relationship of TD3.9 with other TDs**

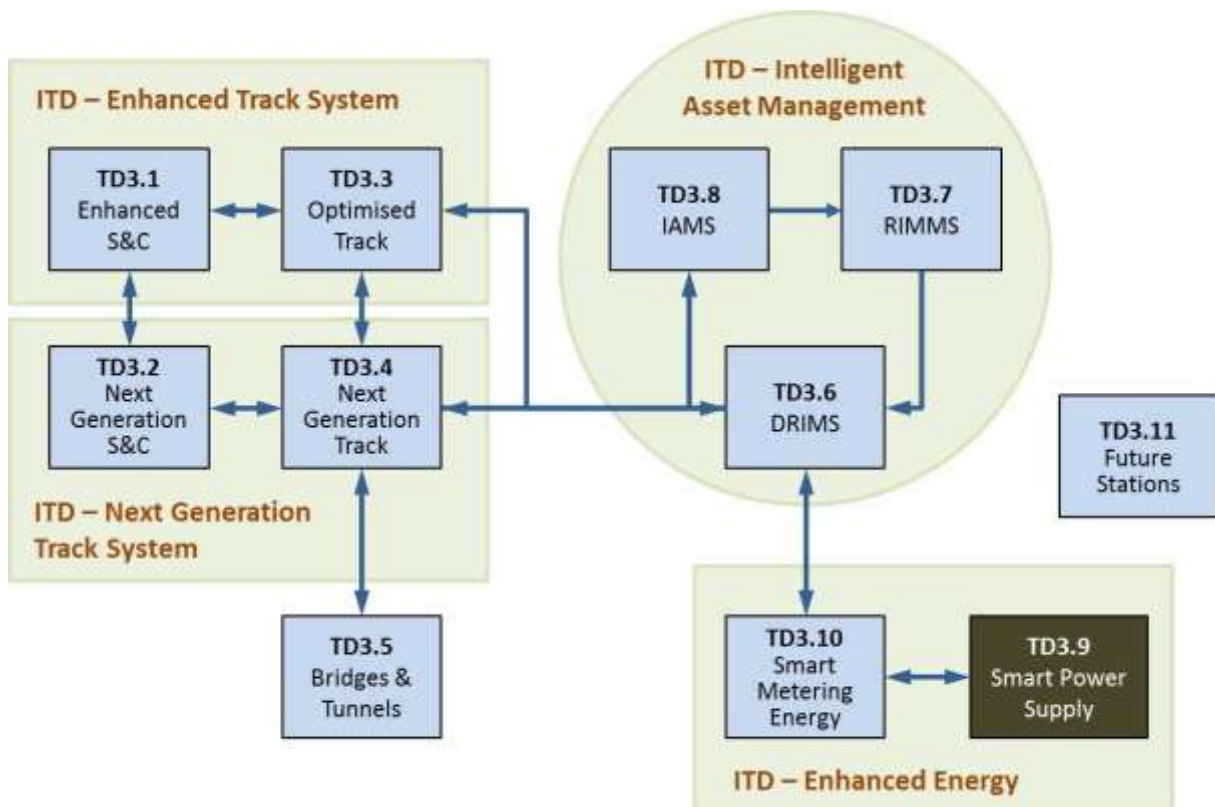

TD3.9 plans to implement two demonstrators to achieve the target functionalities described in the objectives. Using two demonstrators will allow for a wider participation of existing experience in the fields of 16,7 Hz and 50 Hz Rail power supply systems. This will also speed up the process of demonstrator implementation for the different functionalities and allow for optimum integration of academia and SME into the research and investigation process. This will also allow for sufficient results with partly reduced budgets by the implementation of new functionality in existing power grid equipment.

The specification created in In2Rail allows parallel working on both demonstrators and therefore significantly shortens the overall time for developments.

With the restricted budgets an implementation of complete technology demonstrators is impossible. The achievement of TRL 7 requires the participation of railway infrastructure managers with the relevant basic hardware and the possibility of hosting the technology demonstrators. Additionally the functionality in the 50 Hz demonstrator is split into two sequential steps to allow for results at an





early stage, taking into consideration the risks from outer interface to public grid operators as explained in the technical ambition chapter.

### **Approach**

The aim of real operational demonstrators is to show measurable results for the planned functionalities in the railway grid equipment and environment. This will be shown by implementing the following two demonstrators:

#### *Technology Demonstrator for improved control and protection systems:*

This Demonstrator is for control and protection elements in rail power substation with controlled power equipment and covers the following functionalities:

- Digital control, protection and measuring equipment interfacing with existing rail and feeding grid interfaces for all types of operation, and
- Interfacing of Control and Protection with FACTS equipment (Inverter, Balancer, ...).

The demonstrator will show the control and protection schemes including the interfaces and components for smart sensors and actors. Modern communication technology is used with open and standardized protocols. This results in and is shown in an innovative traction substation design. The system will reach TRL7 and will benefit from the work done to TRL3-4 in the Horizon 2020 and Shift2Rail lighthouse project In2Rail. This demonstrator segment is also usable for the following 50 Hz-demonstrator.

The demonstrator is applicable in power supply substations of 16.7 or 50 Hz power grid networks. So an application in 16.7 Hz network is planned as an independent demonstrator, while the demonstration of this functionality for 50 Hz networks will be performed with the Technology demonstrator for 50 Hz .

The improved control and protection functionality can be used also for the energy management system demonstrated within TD 3.10. This will allow for wider demonstration inside TD 3.10.

#### *Technology Demonstrator for 50 Hz Rail power supply*

The demonstrator for 50 Hz substation for Railway grid Interface will allow the demonstration of:

- Parallel Feeding with conventional substations in different modes,
- Load Peak Limitation and management at the interfaces with the feeding grid including the option of energy storage for improved power management and energy efficiency, and
- Voltage stabilisation on the railway power system side.



In a second step, this demonstrator will be used for demonstrating the 3 Phase Feeding Grid Interface functionality as interfaces with and via the railway traction power grid, based on more than one controlled substation in parallel, demonstrating:

- Interacting with the 3 Phase power grid for stabilisation of both grids and showing the target of feeding from Medium Voltage,
- Energy and Power Management for Smart Grid interfaces, and
- Open interfaces for integration of additional power/energy sources with special focus on renewable energy generation (wind, solar,...) into the rail power system.

As explained in ‘Concept and objectives of the Smart Power Supply Demonstrator’, one of the main drawbacks of AC railway power supply is the unbalancing of the three phase system because of the direct single phase connection with the feeding grid. Indeed, because of this connection, connecting two substations in parallel is avoided. Moreover, load peak can easily appear at the interfaces with the feeding grid that can bring voltage stabilisation problems. To resolve these problems, different solutions of proposed demonstrator can be investigated, considering the results from In2Rail research project.

#### ***3.5.9.4. Impact of Smart Power Supply Demonstrator***

##### **Benefits**

The implementation of Smart AC Rail power systems will reduce interferences with the feeding grid, like unbalance, voltage fluctuations, flickering, reactive power, ... This will permit the connection of power supply systems to feeding grids with lower capacity (e.g. 66 kV instead of 132 kV feeding grid), thus reducing investments and allowing efficient rail electrification in areas with weak power networks. Indeed, reducing the investment and reinforce in the national electric grid and power source could be necessary to offer the same energy and power supply availability and reliability.

The specific benefits mentioned in the previous sections have a relevant impact on the Shift2Rail system-level KPIs. The solutions can be applied at 100% of new and existing 50 Hz electrified railway lines.





- Energy efficiency: The implementation will reduce transfer losses in the power supply system by a significant factor,
- Reduced investment: The electrification equipment installed at lineside can have significantly lower nominal power rating,
- Capacity: The line capacity will increase by reducing the sections without power along the line, and
- Operational reliability: With new protection concepts shorter times for fault clearing will improve reliability and availability of the whole system.

In addition the following business benefits will be achieved:

- Reduce the total LCC of the system by less CAPEX investment, higher availability and lower operation costs, and
- Give a future oriented solution applicable around the world, strengthening the competitiveness of European railway industry.

### Technical impact

The following technical impacts are envisaged by the implementation of TD3.1 and have been developed in the context of the three specific Shift2Rail global targets:

Impact type	Shift2Rail Impact	Contribution to KPIs (large spot=high contrib.)
<b>100% Capacity Increase</b>	Increased capacity: The line capacity will increase by reducing the sections without power along the line	
	Increased capacity: The improved substation concept allow for higher power per train	
<b>30% Reduction in LCC</b>	Reduced operation cost: The implementation will reduce transfer losses in the power supply system by 30%	
	Reduced investment: The electrification equipment installed at lineside can have nominal power reduction of 20%.	
<b>50% Increase in Reliability &amp; Punctuality</b>	improved reliability: With new protection concepts shorter times for fault clearing will improve reliability of the whole system	

### Contribution to TSI/Standards

As Smart AC power supply defines new applications, a revision of relevant Standards and regulation may be considered. From today's perspective this covers the TSI Energy and TSI LOC&PAS for implementation and authorisation of the new system. Especially the reduced number of phase separations will improve interoperability impacting the relevant TSI's. This will also reduce maintenance costs (washing and adjusting the phase separation sections) and increase availability via reduced number of broken catenary wire at the phase separation section due to arcing related problems.

Different standards specifying active components, protection principles and systems and for relevant interfaces as EN 50388; EN 50633 and others need to be improved.

EN 50 463 – *Energy measurement on board trains* might be updated to enhance substation/rolling stock energy meter information exchange.



### **3.5.9.5. Implementation of the work programme**

To achieve the final objectives of TD3.9, the activities listed below are planned. Collaboration with owners/operators of railway traction power supply infrastructure is deemed necessary in order to ensure the availability of the relevant expertise and to ensure test capabilities covering the whole market approach.

The **TD3.9 'Smart AC Power supply'** is aimed at defining the necessary basis for the application of Smart AC Rail power systems ready for application, based on prototype testing within technical demonstrators covering the following topics:

- Innovative control and protection systems for traction substations;
- Control concept and specification for integration of FACTS equipment in traction substations
- Control procedures for networks of intelligent substations considering the interaction with rail operation and feeding grid.

Defining the necessary basis for the demonstrator will be based on:

- Load characteristics
- Specifications and interfaces for the transmission system on railway side
- Definitions and requirements regarding feeding network behaviours and interfaces
- Definition of interfaces regarding TMS for power/traffic interaction
- Developing the necessary basis functionality as implementation of new elements and as extension in the substation control functionality enabling:
  - New protection concepts
  - Load Balancing and Paralleling of substations in 50 Hz AC rail power systems
  - Voltage stabilisation to extend feeding ranges

Based on the requirements specifications and dimensioning rules for Power and Control equipments applied in the Smart AC Rail power system will be determined to:

- Defining dimensioning rules and technical basis specification for additional equipment in Smart AC substations;
- Identifying and defining technical parameters and requests from interfaces for functions and elements of Smart AC substations (EMC rules, ...);
- Verifying load cases by simulation based on virtual models for benefit analysis and optimisation rules;
- Specifying virtual models and parameter sets for optimised use cases for demonstrators



The diverse use cases require for different dimensioning rules and control strategies for the equipment. This covers also extensions for protection systems inside the rail power system. Development and implementation will be organized in the following tasks.

- **Task 9.1 Basic Design:** delivers the basic design considering functional specifications, interface definitions and load case and network simulations
- **Task 9.2 Application Design:** covers the design and implementation rules for additional component and controls. This covers also the application of the demonstrators as extension for existing substations.
- **Task 9.3 Test and optimisation:** covers the test of functionality and test optimisation rules under demonstrator conditions.
- **Task 9.4 Assessment:** will define Rules and interfaces necessary for assessment of Smart AC substations and their components at system and component level.

**High level Task Breakdown**

Task	Task Name	Task Description	Lighthouse Project Contribution (%/ Budget)
<b>Task 3.9.1</b>	<b>Basic design</b>	<p>This Task covers the investigations to prepare a proper Basic Design including control and interface specifications for implementation of intelligent AC – substations. This task is in important parts covered by investigations during In2Rail investigation project (up to TRL 3) covering load and grid interfaces, inverter specification and protection principles. To apply the results from IN2Rail for the real demonstrator and to implement in further tasks some additions are necessary.</p> <p>Subtasks are:</p> <ul style="list-style-type: none"> <li>• Coordination of demonstrator design covering load and grid interfaces, Inverter specification and protection principles</li> <li>• Specifications for smart metering systems and equipment. This will be coordinated with TD 3.10.</li> <li>• Adjustment of the requirements and functional specs for implementation in demonstrators</li> </ul>	In2Rail (95% / 0,9 m€)

Task	Task Name	Task Description	Lighthouse Project Contribution (%/ Budget)
<b>Task 3.9.2</b>	<b>Application design and demonstrator installation</b>	<p>In this task the definition and implementation of demonstrators will be worked out. This covers Application Design and implementation of additional components and controls as an extension for existing substation at single location. (TRL 4 to 6/7)</p> <p>Furthermore, the architecture and related test scenarios, test cases and procedures will be defined.</p> <p>To implement the demonstrators in existing substations, the participation of Infrastructure Managers with usable test stations is necessary and needs to be managed by the relevant call. For covering all targets regarding protection principles, balancing and load distribution, an implementation in the different AC-systems is necessary. Preferably this requires the participation of on infrastructure manager with test site on 16,7 Hz power system and one AM with test possibilities for balancing in a 50Hz network.</p> <p>Additional subtasks are:</p> <ul style="list-style-type: none"> <li>• the implementation design and the adaption of control systems.</li> <li>• specifications for smart metering systems and equipment</li> <li>• application design and to the implementation of additional components.</li> <li>• interface specifications for existing networks</li> <li>• implementation of a test station to verify the ‘Technology Demonstrator for improved control and protection systems ‘ within a 16,7 Hz power system.</li> <li>• implementation of a test station and test scenarios to verify the ‘Technology Demonstrator for 50 Hz Rail power supply’</li> </ul>	In2Rail (15 % / 0,8 m€)
<b>Task 3.9.3</b>	<b>Demonstration and tests</b>	<p>The goal of this task is to demonstrate the functionality and the rail power grid integration of ‘Smart AC’ systems and components. This task covers also the demonstration of basic functionalities regarding interfacing with public grids (grid stabilisation, active peak load management, energy storage), the integration of renewable power generation into smart railway grid solutions and compensation for reactive power and unbalance for a single substation. (TRL 4 to 6/7). It also covers the integration with smart metering solutions developed and demonstrated in TD3.10.</p> <p>Main subtasks are:</p> <ul style="list-style-type: none"> <li>• planning and coordination of relevant test scenarios</li> <li>• performing the tests in the different environments</li> <li>• coordination with other involved parties, like power grid companies</li> </ul>	

Task	Task Name	Task Description	Lighthouse Project Contribution (%/ Budget)
Task 3.9.4	Assessment rules and assessment	<p>The goal of this task is to define the necessary requirements, specifications and procedures to authorise 'Smart AC power supply' systems and equipment for the European railway system and also regarding the interfaces with public grids. This task requires additional experienced partners regarding assessment and assessment. An integral part of the assessment will be the evaluation of the demonstrator performance including the calculation of KPIs on the railway system level.</p> <p>The defined assessment and assessment rules will be verified in an operational environment.</p>	

### 3.5.9.6. Planning and budget

#### TD3.9 Gantt Chart

TD3.9 - SMART POWER SUPPLY DEMONSTRATOR		2015				2016				2017				2018				2019				2020				2021				2022				2023				2024			
Task	Description	Q1	Q2	Q3	Q4	Q1	Q2	Q3	Q4	Q1	Q2	Q3	Q4	Q1	Q2	Q3	Q4	Q1	Q2	Q3	Q4	Q1	Q2	Q3	Q4	Q1	Q2	Q3	Q4	Q1	Q2	Q3	Q4	Q1	Q2	Q3	Q4				
3.9.1	Basic design																																								
3.9.2	Implementation of Demonstrator for improved control and protection systems																																								
3.9.3	Technology Demonstrator for 50 Hz Rail power supply																																								
3.9.4	Demonstration of power grid interface capabilities																																								

#### TD3.9 Budget

The estimated budget for the TD is around 7.5M €.





### **3.5.10.TD3.10: Smart Metering for Railway Distributed Energy Resource Management System Demonstrator**

#### **3.5.10.1. *Concept and objectives of the Smart Metering Demonstrator***

##### **Context**

The detailed mapping of energy consumption of a railway system is mandatory for energy efficiency analysis and management. The knowledge of load curves at rolling stock level, at traction substation level and at auxiliary services level will allow global system load prevision, peak-shaving, and energy cost optimisation. It will also highlight where the most effective actions could be implemented to give energy savings.

##### **Definition and justification of objectives**

The objective of Smart Metering Demonstrator is to achieve a fine mapping of different energy flows within the entire Railway System, as the basis of any energy management strategy is built on a fine knowledge of the dynamics of all consumers and generators energy flows. Based on reliable real time measurements, a decision can be taken on the best choice of energy efficiency improvement strategy. The demonstrator will validate a standard measurement architecture coordinating on-board and ground measurements and provide the energy data analytics in a Big Data type Operational Data Management (ODM) platform. The measurements and the data analysis will allow exploitation by User Applications and a Railway dedicated Distributed Energy Resource Management System (RDERMS).

Objectives	Result	Deliverable
Standard energy measurement architecture coordinating on board and infrastructure measurements.	Energy comprehensive quantification at system level	Specification, development and demonstration of railway system scale Smart Metering concept.
Energy Data Analytics and User Applications for energy savings and optimized interaction with the Energy Market.	Design of scalable User Application tools and techniques required for the rail industry and related market players to extract, visualise and interpret pertinent energy data. The User Applications and RDERMS will be able to provide resources for an Aggregator, thus enabling a market place for an offer and a better negotiation of the energy contract	Specification, development and demonstration of the ODM and the associated Applications.
For the Railway Undertaking: operational and strategic decisions leading to energy savings.	Optimisation of time tables, of trip times, etc. impacting energy consumption and still being acceptable for the system operational performance	Specification, development and demonstration of how train operating modes changes influence energy consumptions. Definition of correlation functions between railway equipment and power/energy consumption
For the Infrastructure Manager: close monitoring of the electrical infrastructure, both dedicated to traction and to auxiliary services. Measurement of different power flows correlated to trains operation, as well as energy consumption and preventive maintenance improvements. Refined evaluation of investment needs for energy storage, energy recovery, energy management devices and FACTS.	Better knowledge of continuous electrical infrastructure equipment energy flows and states. Optimized ROI and a proven business plan. Better anticipation of auxiliary services energy needs. Optimized Maintenance of railway electric infrastructures and improvement of their LCC.	Development and demonstration of specific use cases in terms of data collection for energy management and continuous control availability. Extraction of indicators corresponding to economic expenses, efficiency with stochastic parameters. Specification, development and demonstration of auxiliary services smart metering and a maintenance application. Business Plan.

The concept of the demonstrator is represented in the figure below and the associated objectives are summarized as follows:

- To realize a non-intrusive Smart Metering sensor network at a Railway System level.
- To realize an open system and interface for data collection, aggregation and analysis in an open source ODM (Operational Data Management) Platform.
- To realize a set of User Applications design and specifications. The Applications will exploit the energy analysis process with the aim of enhancing the energy decision making and the line operation patterns, as well as other possible improvements such as preventive maintenance.

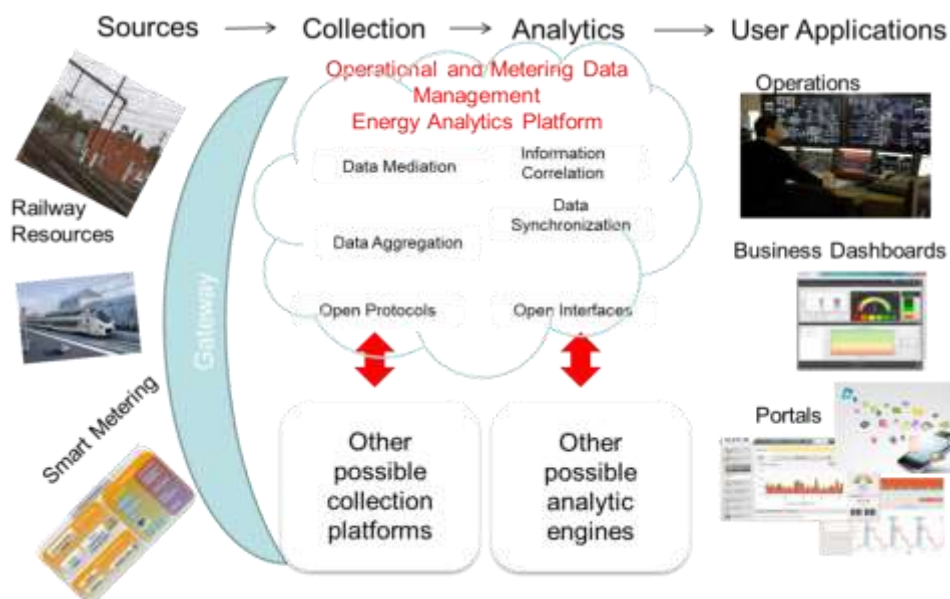
**Figure 89: Demonstrator Concept****Alignment with Shift2Rail Strategic Master Plan**

The TD 3.10 is, by its nature, providing energy related information and data at the whole railway system level. Therefore, it is totally in line with the system approach of the Shift2Rail Strategic Master Plan. The TD 3.9 is really focused on the performance improvement of the railway system by contributing to its understanding and management as a whole and by providing the tools for information exchange between different stakeholders within the system.

The holistic view given by the TD 3.9 outcomes is completed by the contribution to the European industry leadership on the global market of rail products and services. The innovative solutions implemented in the energy data collection and analytics are answering to the global energy market needs of consumption and generation previsions. The railway is one of the largest electricity consumers in many European countries, but the complex interactions between moving loads and infrastructure are not fully monitored today.

The TD 3.10 will also contribute to the investments and operation costs reduction through the information feedback provided to different railway actors, from manufacturers to operators and infrastructure managers.

Finally, the customer will be kept in the informational chain loop and the TD 3.9 outcomes could contribute to a better transport multimodal approach.

**3.5.10.2. Technical ambition of the Smart Metering Demonstrator****Ambition**

Nowadays, information and communication development is experienced worldwide due to the emergence of wireless and mobile technologies in different sectors: communication, health, environment, military, etc. Innovations are registered as integrating these technologies in various



applications in order to have a competitive advantage in the business world. An 'E-concept' is now introduced as a quicker, easier and more reliable way to meet the demands of the future world.

The Railway Transportation Systems is no exception, as smart metering can provide real time information allowing the optimisation of energy consumption. Wireless and mobile devices can be used for railway metering. For example, a GPS/GSM based train tracking system can provide accurate, dependable and timely information to the controller. The GPS module, built-in most smartphones, locates the train and location data is then transferred to the controller via GSM to the Geographical Information System (GIS) where data processing provides a visual positioning on a predefined map.

In addition, the train speed and status (accelerating, braking, maintain speed, etc.) can be measured using an accelerometer, a common sensor that can be found in most smartphones. Once measuring location and speed, efficient decisions can be made on different levels such as managing energy flow, optimizing speed profile, rescheduling trains, etc. In general, based on the concept of data fusion, information can be gathered from different distributed sensors on board and at ground level (accelerometers, GPS, voltmeter, ampere meter...), combined to produce a comprehensive database with a common time and spatial reference. Once the database is ready, user customized applications will evaluate the current situation and finally enhance the decision-making process.

An important scientific work will be performed in order to implement intelligent algorithms for energy consumption evaluation using as less sensors as possible. The measurements must be as much as possible non-intrusive and cost effective. The main effort will be concentrated on intelligent evaluation solutions rather than on measurement hardware (sensors, data loggers, etc.). For example learning algorithms could be used in order to precisely evaluate the energy consumption by only measuring acceleration and speed. This could be a way to limit the usage of current and voltage sensors and their associate interface devices.

A proposed functional architecture is represented in the figure below:

**Figure 90: On-board sensor network functional architecture**

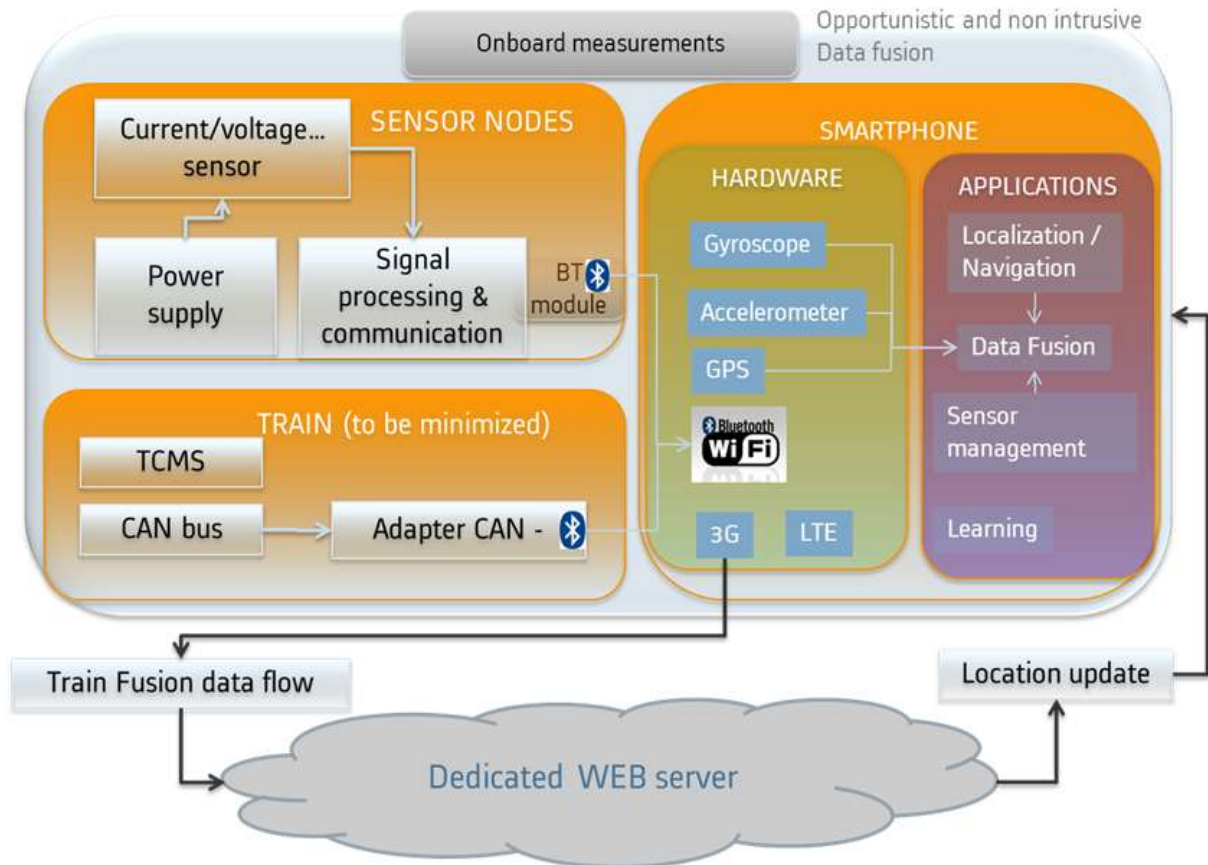

The integration in the future Smart Grid allowing energy exchange between the railway and alternative generation modes such as renewables or local distributed generation is conditioned by the deployment of a smart metering network. At the infrastructure level the functional architecture integrating the sensor network, the railway elements and the alternative energy sources is described below:

**Figure 91: Sensor network functional architecture applied to Smart Grid integration**

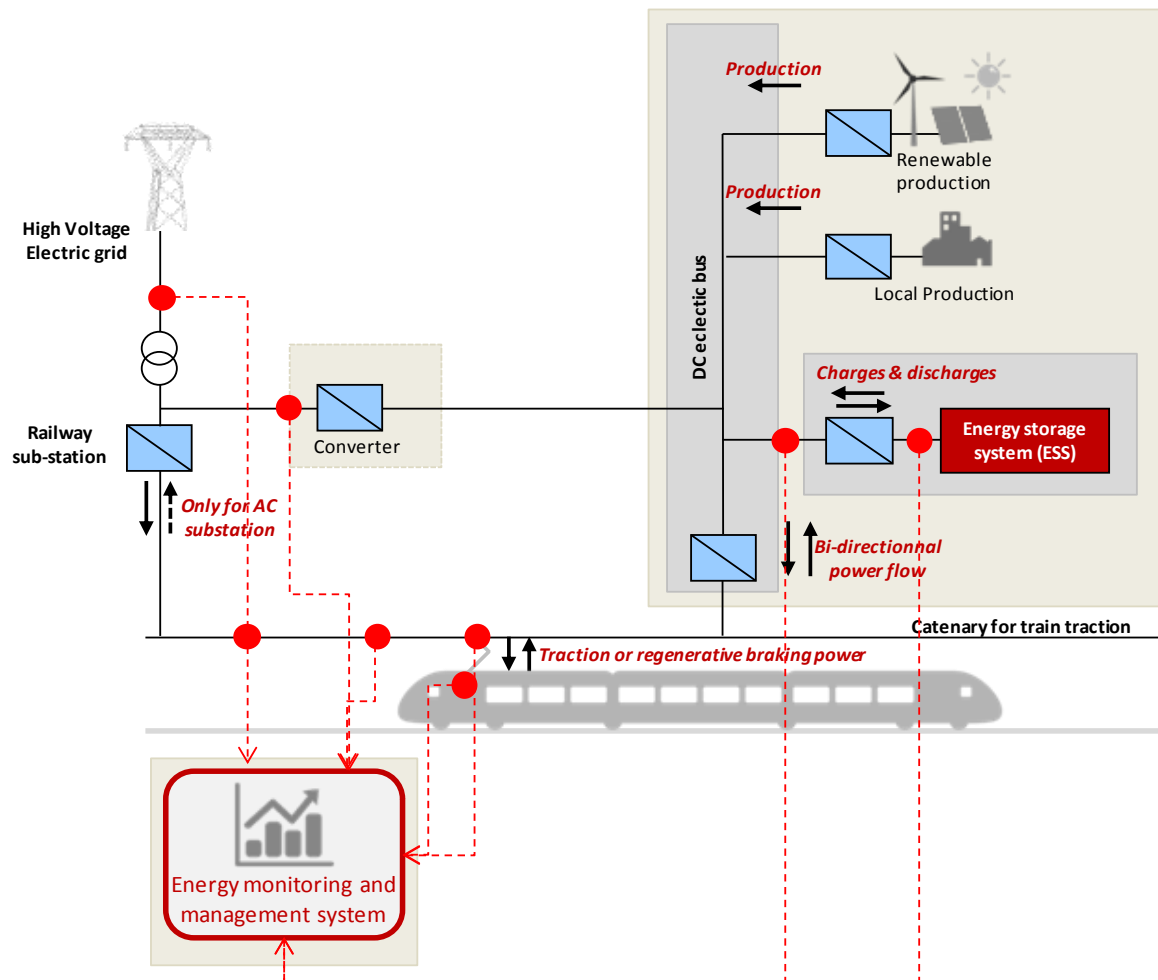

### **Market Uptake**

Information and communication technologies (ICTs) and sensor networks in particular have the potential to contribute to increased efficiency in both freight and passenger rail transport.

The TD 3.10 will develop the convergence between energy and telecommunications services in the railway domain. The smart meter is a prime example of smart grid technology that blends electricity provision and consumption with advanced communication requirements. There is a potential need for open access provisions allowing smart meter service providers and utilities access to data capacity over telecommunications networks.

The TD 3.10 concept is well placed on the development roadmap of both Smart Grids and Intelligent Transportation. These two sectors are fully developing today and the smart metering solution



proposed is bringing innovation and value-chain disruption by providing new services or services formerly reserved to electricity utilities only. For example, electricity data will be used to provide intelligence to railway stakeholders and customers.

The TD 3.10 aims also to maximize interoperability between railway systems and/or industries. Regarding the Monitoring & Control architecture, the choice of open industrial and Web standard will maximize the interoperability between on-board and ground components. So target will be both hardware and software vendors, as a result of extending the market acceptance to other interest groups than the originals industrials players.

The today needs of public transportation in terms of energy reduction are well summarized in the UITP “Energy Reduction Strategies” paper. One of the major topics is Monitoring Energy Flows: “To develop efficient energy saving strategies, monitoring is of critical importance. It is necessary to know where, when, how and how much energy is consumed and generated at all times and at all locations within a public transport system. Monitoring cannot be considered an energy reduction strategy in itself; it is an absolutely necessary tool to enable the evaluation of the efficiency of any strategy that is applied.”

#### **Technology progress beyond the State-of-the-Art**

Nowadays only customised on board system measurement devices are available. They are mainly focused on the rolling stock internal energy flow with the aim of measuring separately the energy used for the traction and the other auxiliary energy usages.

The concept novelty comes from the system level measurement integration which provides synchronized measurements on-board and at ground. The other main feature is the path provided by the RDERMS to the energy market with an enhanced prevision capability.

Thirdly, the today mobile information technology makes affordable quite sophisticated mobile terminals such as smartphones to industrial applications such as sensor networks.

State-of-the-art	Advance beyond the state of the art
The state of the art today shows a focus on rolling stock on-board energy meters for energy billing purposes at pantograph.	Railway System level measurement integration which provides synchronized measurements both on-board and trackside. The other main feature is the path provided by the RDERMS to the energy market with an enhanced prevision capability
System energy consumption is usually measured at the substations only and averaged over a defined period of time, which does not allow for an exact energy analysis. This is actually done by simulation algorithms based on models that make simplified assumptions on real conditions. No correlation with trains operations is made after measurements.	Energy flows are mapped for the whole railway system, continuously and with refined granularity. Customized user applications based on real measurement data analytics, not only on simulation.
The current rolling stock metering systems are quite intrusive, requiring relatively long implementation.	Solution based on the non-intrusive technology and quite sophisticated, but on-the-shelf and mass marketed, mobile terminals such as smartphones dedicated to industrial applications such as sensor networks. Embedded applications open a wide possibility of local processing data from direct measurements and estimations in order to enhance the sensor capabilities towards a wide range of measurements.

Going beyond the sensor network deployment in a Railway System, the Demonstrator will provide a data collection and processing system which will allow the building of User Applications in an open source software environment. The User Applications development is linked to many outcomes from past projects such as RAILENERGY for the KPIs evaluation and also as MERLIN for the integration within a railway Smart Grid concept.

Below are presented three possible domains of applications which are nowadays not yet widely developed because of lack of reliable real life energy data defined with fine granularity in time and space.

Firstly, the measurements can be used for operational decisions leading to energy savings, such as modification of time tables, of commercial trip times, etc. which in return will reduce the energy consumption and still be acceptable for the system operational performance. In the same way, increasing the operational capacity without heavily increasing the energy consumption can be achieved.

A second benefit will be the refined evaluation of investment needs in energy storage, energy recovery and energy management devices in order to achieve an optimized ROI and thus demonstrate the business plan.

Thirdly, the continuous monitoring of infrastructure energy consumptions will provide useful information for the preventive maintenance of sub-systems and components by highlighting abnormal energy patterns.





Last but not least, the effective use of the energy resources in a railway power supply system and their integration into a feeding grid require access to the energy market. The Smart Metering Demonstrator will show the different ways to interact with the energy market through different User Applications based on energy data analytics of the Railway energy system.

The key areas to focus the technical ambition will be:

- Adaptation of the wireless sensor networks to railway energy networks measurements.
- Autonomous supplied sensor nodes.
- Data aggregation and data fusion algorithms.
- Energy consumption estimation algorithms for non-intrusive measurements.
- Analysis of smartphone or other low cost communicating sensors for on-board and track side energy measurements.
- Development of embedded learning algorithms for energy estimation and mobile device navigation applications.
- Development of a global architecture for the data collection, data synchronisation, post-processing, analysis and applications.
- Integrate the railway applications in the generic energy analytics ODM platforms as a distinct use case.

### **Technical Limitations/Barriers**

The technical limitations and barriers are generated for a part by the technical ambition key areas, such as using consumer or low cost network sensors in a railway harsh mechanical and electromagnetical environment and for another part by the fear that security and privacy of data gathered by smart metering could raise some technical issues.

Building up a smart metering infrastructure is a highly demanding technical task. Commercially available smart metering components are not adapted to railway industry and lack of interoperability. A special attention will be paid to the compatibility with the EN 50463 standard in order to define interoperability specifications and use the benefits of already defined open platforms for data collection.

The following major risks are foreseen for the TD.

Nº	Risk description	Mitigation action proposed
1	Commercial available smart meters not adapted to railway environment.	Integration Plan regarding railway standards to be applied. EN 50463 gap analysis.
2	Data privacy and security.	Data Management Plan including eventual encryption standards to be applied.



### **References to existing EU funded research projects**

Potential synergies can be found with the following FP6, FP7 and H2020 EU-funded research projects:

Acronym (EC Reference)	Description of Project
<b>RAILENERGY</b> (GA 31458)	The overall objective of Railenergy is to cut the energy consumption within an optimised railway system thus contributing to a reduction in the life cycle costs of railway operation and of CO2 emissions per seat/kilometre or tonne/kilometre.
<b>MERLIN</b> (GA 314125)	Optimisation concepts and proposals for minimising energy demand
<b>IN2RAIL</b> (GA 635900)	IN2RAIL is to set the foundations for a resilient, consistent, cost-efficient, high capacity European network by delivering important building blocks that unlock the innovation potential that exists in Shift2Rail

#### **3.5.10.3. Specific Demonstration activities and contribution to ITDs/SPDs**

##### **Vision**

An important integration development between TD3.9 and TD3.10 is carried out in IN2RAIL in the field of infrastructure energy data collection and analysis. As shown in Figure 92 below, the improved control and protection functionality of TD3.9 will be also used for transmitting data to TD 3.10. In return, within TD3.10 the KPIs evaluation and other User Applications will enhance the energy management in TD3.9.

Figure 92: Relationship of TD3.10 with other TDs.

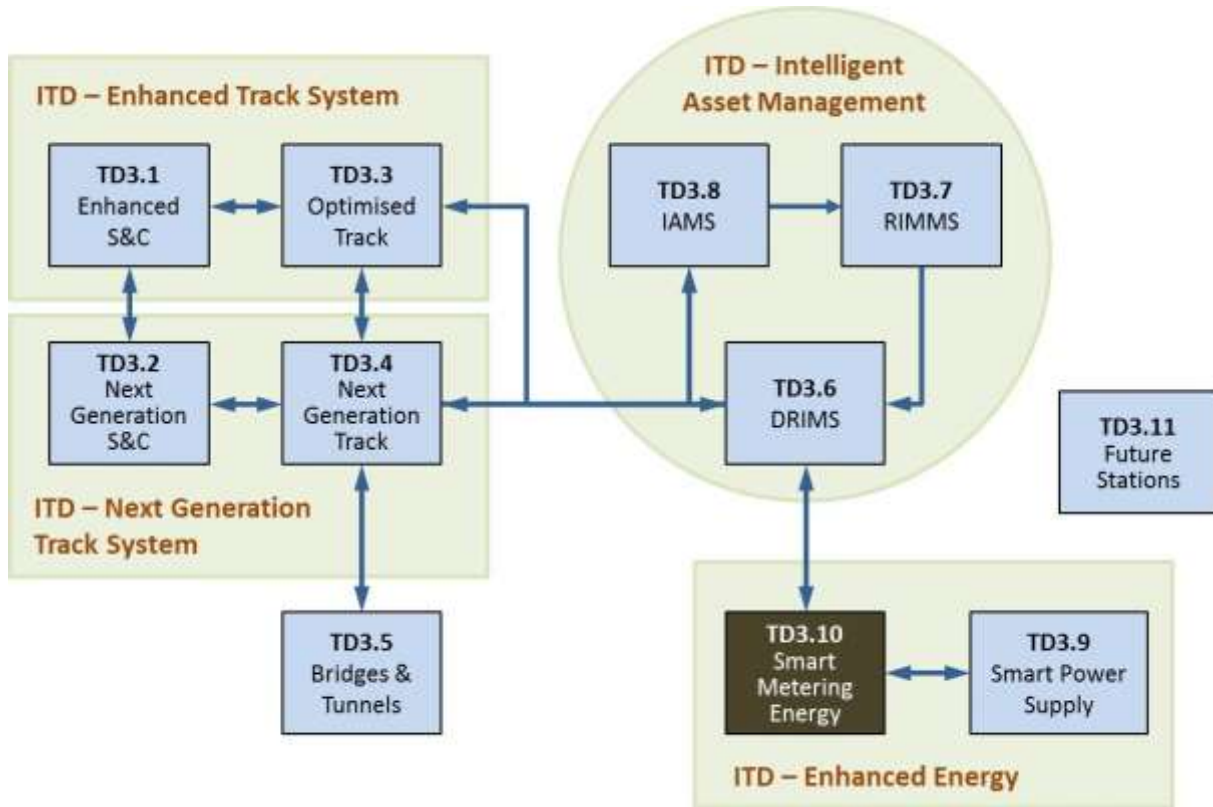

Both Technical Demonstrators will achieve TRL 7 and contribute to an Energy ITD development.

Figure 93: Energy ITD concept

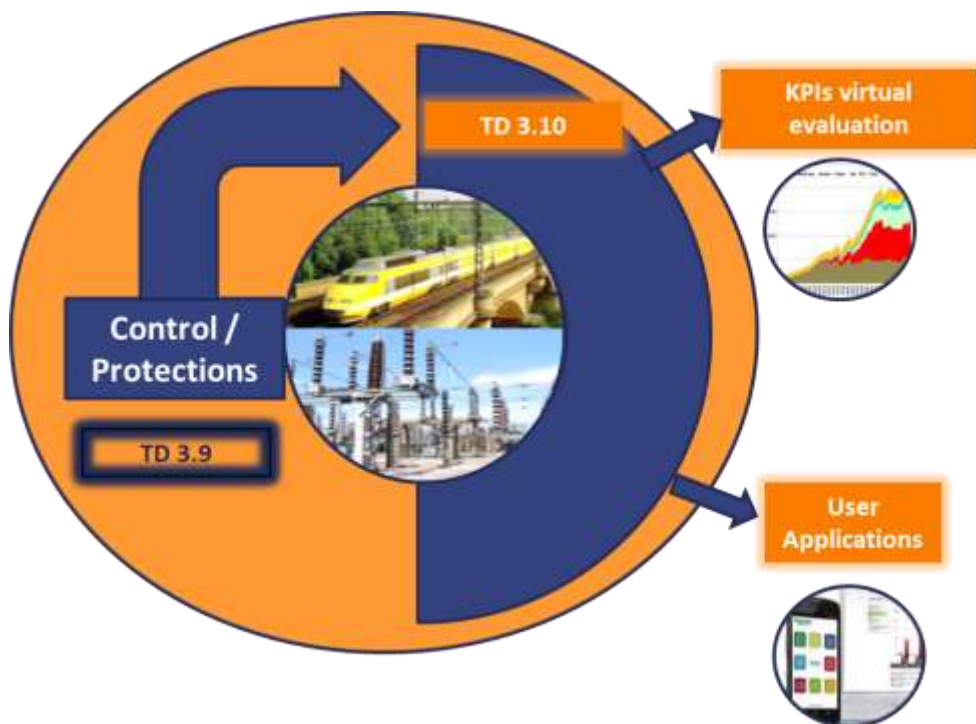



#### **3.5.10.4. Impact of the Smart Metering Demonstrator**

An analysis of the positive impacts of smart metering for energy management purposes can be highlighted for several use cases specific to the main rail transportation energy consumption profiles, for example:

##### **Metro and sub-urban:**

- Valorisation of braking energy.
- Better management of train lighting and air conditioning/heating when not in revenue service.
- Better station energy management.

##### **Regional passenger:**

- Providing an accurate energy measurement tool leading to energy savings plans specific to each region (a variation of +/- 20% is expected in function of each region due to specific timetable constraints and climatic conditions).
- Allowing the optimisation of the energetic mode choice (electric/diesel)
- Reducing the energy bill at a regional scale by adapting the best purchasing profile to the real time consumption and allowing energy aggregation with regional consumers.

##### **Freight:**

- Better valorisation of the off peak hours used by the freight.
- Better management of energy consumption when the freight train is stopped.

##### **Inter-Regional and High Speed Passenger:**

- Valorisation of braking energy
- Better management of train lighting and air conditioning/heating when not in revenue service.
- Better coordination between the energy hourly variation prices and the traffic operation.

##### **Infrastructure:**









- Continuous supervision of power supply equipment states.
- Better knowledge of energy flows and consumers.
- Optimized ROI and a proven business plan, allowing optimal investment in local reversible DC substations or storage devices.
- Better identification of electric infrastructure losses.
- Better identification of auxiliary and stations energy consumption and of opportunities for savings and demand-response.

- Improved reliability and LCC based on predictive maintenance by continuous supervision of energy consumption and identifying the abnormal variations.
- Increasing the power supply quality and optimizing the line capacity.

The specific benefits mentioned in previous sections have a major impact in the Shift2Rail system-level objectives. But measurements only will not directly provide the improvement of the objectives. Measurements will provide the knowledge of real life energy data which will allow the most efficient energy management actions. These actions will be simulated, since it is out of the scope of this TD to interfere with the real operation of a railway system. For example, it will be very difficult to modify the real timetable of an operator on the timescale of the evaluation task, so the benefits will be measured by simulating 'what if' scenarios and calculating the relevant improvements.

### **Technical Impact Table**

In this context, the following technical impacts are envisaged by the implementation of TD3.10 and by taking appropriate actions using the measured data. They have been developed in the context of the three specific Shift2Rail global targets:

Impact type	Shift2Rail Impact	Contribution to KPIs (large spot=high contrib.)
<b>100% Capacity Increase</b>	Improving the operational timetable design process by taking into account the energy criteria based on continuous measurement data.	
	Intelligent asset monitoring and sensing technologies reducing the frequency of manual inspection and maintenance activities.	
	Greater capacity to run more trains without heavily increasing the energy consumption.	
	Increased network availability through enhanced, predictive maintenance capabilities reducing disturbance of operations.	
<b>30% Reduction in LCC</b>	Intelligent energy measurement tools providing the basis for the implementation of energy management measures leading to energy savings.	
	Increased competitiveness of railways due to energy bill savings and intelligent asset management. Optimized energy tariffs due to systematic shaving of peak loads based on smart metering data	
	Generates low cost solutions by generating data for accurate design which avoids equipment over-dimensioning.	
	Improving new investments ROI by allowing refined business plans for new technology (storage, energy recovery, etc.) implementation.	
<b>50% Increase in Reliability &amp; Punctuality</b>	Increased operational reliability due to electrical infrastructure predictive maintenance by continuous monitoring of energy consumption variations from expected values.	











### **Contribution to TSI/Standards**

The development and the results of the TD 3.10 will contribute to the energy evaluation related TSI and Standards, such as:

- CLC/TS 50591: Specification and verification of energy consumption for railway rolling stock.
- EN 50463: Railway applications. Energy measurement on board trains.

One of the foreseen applications of the synchronized on board and substation energy measurements is the losses evaluation and attribution to different types of rolling stock. This could enhance the energy billing method for further TSI/Standards versions.

**Strategic Impact Table**

Impact type	Shift2Rail Impact	Contribution to KPIs (large spot=high contrib.)
<b>Support the competitiveness of the EU industry</b>	<ul style="list-style-type: none"> <li>• Global technological leadership supported by a combination of innovation and technical standards, setting an effective advantage for the European industry:               <ul style="list-style-type: none"> <li>○ Enhance the Energy Management at the level of Railway System.</li> <li>○ Application of Big Data concept to Railway energy data management and its extension to other data types such as maintenance and asset management ones.</li> </ul> </li> </ul>	
	<ul style="list-style-type: none"> <li>• Increase attractiveness and competitiveness:               <ul style="list-style-type: none"> <li>○ Increase of operational reliability: less service disruptions through continuous monitoring of subsystems energy consumption.</li> <li>○ Reduce cost: smart metering infrastructure cost reduction by using non-intrusive and standard components. Also, energy cost reduction by using measurement results for Energy Management applications.</li> <li>○ Increase capacity: by a more rational energy usage, optimising the asset management and the need of new energy infrastructure dedicated to capacity increase.</li> </ul> </li> </ul>	
	<ul style="list-style-type: none"> <li>• Enhanced customer experience: the final customer can access through dedicated portals the energy data related to his own trip and thus contribute to energy savings by changing travel habits.</li> </ul>	
<b>Compliance with EU objectives</b>	<ul style="list-style-type: none"> <li>• Promotion of modal shift: throughout customer dedicated User Applications using geolocation data and real life measurements, and not only pre-defined timetables, an effective promotion of modal shift is achievable.</li> </ul>	
	<ul style="list-style-type: none"> <li>• Greening of transport: using real energy consumption data and evaluating the environmental impact accordingly, the customer will act directly on the transport greening.</li> </ul>	
	<ul style="list-style-type: none"> <li>• Achieve single European Rail Area (SERA): by promoting data exchange formats and protocols.</li> </ul>	
	<ul style="list-style-type: none"> <li>• Enhanced interoperability: facilitating the detailed energy consumption knowledge will promote operation costs reductions for all operators.</li> </ul>	
	<ul style="list-style-type: none"> <li>• Simplified business processes: energy data detailed cost sharing will simplify the business cases elaboration.</li> </ul>	
<b>Degree of maturity of the envisaged solutions</b>	Currently most of the proposed technologies are in TRL 1,2 (Principles observed and the possibility of using them formulated). At the end of Shif2Rail it is expected that the successful concepts are brought to TRL 6 or 7.	



### **3.5.10.5. Implementation of the work programme**

#### **Overall approach and methodology**

It is foreseen that the activities should reach TRL 7, providing the functional tests of components and sub-systems. In the table below, the following tasks are proposed with a view to achieving the objectives of the TD.

These objectives require a high level of expertise and railway assets management responsibilities in the following domains:

#### **Indicative list of activities/required expertise from AMs/Open Calls**

In addition to the type of expertise and skills provided by the founding members of the S2R JU, the following complementary assets, expertise and skills would be required to carry out the above tasks:

- Ownership of railway systems and operational activities: train operation, infrastructure management, energy purchase.
- Expertise in big data analysis and associated software technical support
- Expertise in telecommunications for data collection and transmission
- Expertise in user applications development
- Expertise in the design and integration of Data Management system, Sensors and Metering Design and Applications design
- Experience with railway systems testing facilities
- Expertise in the global assessment of functional performances (gap analysis).
- Expertise in smart metering data collection
- Expertise in energy market operation



**High Level Task Breakdown**

Task	Task Name	Task Description	Lighthouse Project Contribution (%/ Budget)
<b>Task 3.10.1</b>	<b>General Specification</b>	<ul style="list-style-type: none"> <li>Specifications of the needs, the constraints and the overall scope in order to deliver the preliminary architecture technical specifications. The main deliverable will be the Preliminary Architecture Technical Specifications.</li> <li>Collect and specify needs in terms of new applications from FM, AM and OC that are not participating in IN2RAIL.</li> </ul>	In2Rail (90% / 0,37 €m)
<b>Task 3.10.2</b>	<b>Architecture Design</b>	<ul style="list-style-type: none"> <li>Design of all TD components, including on-board, track-side and data collection, processing and storage hardware and software. The task will deliver the Technical Specifications, laboratory proof of concepts, Design plans and Bill of Quantities.</li> <li>Adaptation of Architecture Design and Final Design. Following the handover of the basic architecture design and specifications from IN2RAIL the final design has to be made in accordance with the decision for the specific demonstrators, including those from FM, AM and OC that are not participating in IN2RAIL.</li> </ul>	In2Rail (83% / 2,13 €m)
<b>Task 3.10.3</b>	<b>Demonstrator Implementation</b>	<ul style="list-style-type: none"> <li>Physical implementation both trackside and on-board, software implementation and data server implementation.</li> </ul>	
<b>Task 3.10.4</b>	<b>Demonstrator Integration Tests</b>	<ul style="list-style-type: none"> <li>Functional tests of components and sub-systems, integration functional tests, conformity with the technical specifications of the whole system, including the demonstration of energy management and the study regarding the energy bill optimisation.</li> </ul>	
<b>Task 3.10.5</b>	<b>Preparatory work for assessment</b>	<ul style="list-style-type: none"> <li>Demonstrator system assessment preparation regarding the European regulations.</li> </ul>	
<b>Task 3.10.6</b>	<b>Demonstration and assessment</b>	<ul style="list-style-type: none"> <li>KPI calculation and simulation of the energy efficiency benefits at railway system level, driven by specific User Applications such as energy management and energy bill optimisation. Gathering performance data and demonstrator assessment, including technical and economic aspects.</li> </ul>	

**3.5.10.6. Planning and budget**

**TD3.10 Gantt Chart**

TD3.10 - SMART METERING DEMONSTRATOR		2015				2016				2017				2018				2019				2020				2021				2022				2023				2024							
Task	Description	Q1	Q2	Q3	Q4	Q1	Q2	Q3	Q4	Q1	Q2	Q3	Q4	Q1	Q2	Q3	Q4	Q1	Q2	Q3	Q4	Q1	Q2	Q3	Q4	Q1	Q2	Q3	Q4	Q1	Q2	Q3	Q4	Q1	Q2	Q3	Q4	Q1	Q2	Q3	Q4				
3.10.1	General specification																																												
3.10.2	Architecture design																																												
3.10.3	Demonstration implementation																																												
3.10.4	Demonstrator integration tests																																												
3.10.5	Preparatory work for homologation																																												
3.10.6	Demonstration and assessment																																												

**TD3.10 Budget**

The estimated budget for the TD is around 7.5M€.



### **3.5.11.TD3.11: Future Stations Demonstrator**

#### **3.5.11.1. *Concept and objectives of the Future Stations Demonstrator***

##### **Context**

From a major urban station to a provincial stop, stations are an important element of the railway system and one of the most complex. The major civic stations have become destinations in their own right and dynamic places of commercial, retail and social activity. Stations located in major urban areas are likely to have issues with congestion, orientation and security that are not experienced in more remote stations.

TD3.11 is a plan to develop station design concepts optimising station management, creating cost effective solutions and technologies so they can be applied in a variety of scenarios. The primary ambition is for customer experience at stations to be dramatically improved, increasing the number of customers that will use rail as their preferred transport mode.

##### **Definition and Justification of Objectives**

TD3.11 Future Stations addresses the primary objective of improved customer experience via four parallel work-streams considering future demands for large and small stations. Common to all of them is the theme of improved customer service by improving efficiency, cost effectiveness and security.

Two of the objectives are uniquely concerned with improving capacity and security in large stations (TD3.11.1 and TD3.11.4).

The subject of TD.11.2 is an exploration of how small stations can be designed, bringing in the wealth of the European construction industry and aiming for identification of suitable components, lighting and specifications that will result in standardisation and all its benefits.

Common to all stations is the issue of accessibility which is equally important in a large station as it is in an unstaffed remote station. TD.11.3 seeks to provide answers to the very difficult problem of everyone being able to alight the train efficiently and safely.

The four work-stream objectives are as follows:

	Objectives	Result	Deliverable
<b>TD3.11.1</b>	Improved flow between platforms and concourse	Improved congestion management in large stations; seamless end to end journey; accessibility and perturbation control in urban based stations using passenger capacity modelling tools; exploration of dynamic wayfinding systems.	Innovative revenue control and live passenger and train data, at TRL5
<b>TD3.11.2</b>	Improved Station Designs and Components	Classification of European Construction Industry components suitable for use in small stations with a view to reducing whole life costs and standardising design where possible. This might be demonstrated as part of implementing a small station rather than constructing prototypes.	Station Components Specifications and Design Prototypes, at TRL5 with potential for a new small scale working station at TRL7
<b>TD3.11.3</b>	Improved Accessibility to Trains	Analysis of the Platform to Train Interface (PTI) issues and testing of suitable solutions for existing stations, to allow safe and inclusive access while minimising dwell time of the train at the station.	Tested PTI strategies, at TRL5, for all the possible conditions in existing stations. Potentially for integration with TD1.6
<b>TD3.11.4</b>	Emergency Strategies for major stations	A better understanding of existing security and emergency shortfalls in large stations should lead to the development of a European wide methodology for dealing with such issues that will supported by other European initiatives in this field.	Operational tools and strategies for dealing with emergency, at TRL7

### Expected Achievements

#### **TD3.11.1 Crowd Management and Revenue Protection in large stations**

This work-stream will investigate ways to increase station capacity with new ticketing technology that could potentially remove the need for gates in stations, encouraging seamless journeys while ensuring that operators do not lose revenue. This will be done in a way that will not compromise the security of the station and will consider alternative security measures if necessary.

The same technology will also be considered for improving wayfinding in the station anticipating possible interface with IP4.



### **TD3.11.2 Standardisation and Prototypes for small stations**

An assessment of construction products that are available throughout Europe will seek to identify the most suitable materials and finishes for station components. This may include trials of innovative building materials and components (lighting for example) in the station environment. It is proposed that prototype station designs for small stations will be developed demonstrating a service based approach to station design and flexibility in adapting to future requirements.

The study will conclude with recommendations on appropriate specifications and maintenance regimes depending on use and locality.

### **TD3.11.3 Platform to Train Accessibility**

The transition from the train to the platform is a major issue not only for wheelchair users but also for the majority of users and especially those with prams and luggage. It is also a major safety concern especially on curved platforms or on routes with varying train carriage heights. To address the above issue of Platform Train Interface (PTI) a study will be undertaken that develops the optimum PTI configuration to achieve safe and consistent boarding and alighting.

The study will then form the basis from which European countries can meet and address in a cost-effective manner their PRM interoperability objectives and commitments.

### **TD3.11.4 Emergencies Risk Assessment of major stations**

This work-stream will utilise existing passenger flow software as a real-time means to understand the crowding issues in a station and control them with mitigating measures such as directing the crowds to alternative routes or exits. It will seek to develop appropriate tools and procedures to assist large station operations.

### **Alignment with Shift2Rail Strategic Master Plan**

TD3.11 will align to the Strategic Master Plan objectives through the following:

- Global technological leadership supported by a combination of innovation and technical standards, setting an effective advantage for the European industry.
- Increased attractiveness for end users through:
- Establishment of a streamlined, well defined and largely virtualised validation processes that allows for a fast track towards implementation and world-wide marketing
- Promotion of modal shift through more reliable and affordable rail travels.
- Increased societal safety by a modal shift from road (where tens of thousands of Europeans are killed every year), to rail which is of an order of 50–100 times safer.
- Greening of transport through the modal shift, but also through new more environmental friendly constructions.



- Achieve single European Rail Area (SERA) through modularisation, standardisation, and a harmonised assessment methodology for innovative solutions.
- Facilitating interoperability by higher capacity, and more reliable rail operations that enhance the logistic reliability in cross-modal transports.
- Simplified business processes harmonised assessment methodology for innovative solutions.
- Dependent on specific solutions in the tested demonstrators they are envisaged to have a TRL of 5 to 7.



### 3.5.11.2. *Technical ambition of the Future Stations Demonstrator*

#### Ambition

The following table summarizes how this TD will progress the state-of-the-art and overcome today's limitations:

	State-of-the-art	Advance Beyond State-of-the-art (Shift2Rail)
TD3.11.1 Crowd Management and Revenue Protection in large stations	Gated barriers for revenue control; Reliance on CCTV cameras to provide station staff visual information and surveillance of the station.	Increased capacity in busy stations by removing gate barriers currently used for revenue control. Revenue control will be integrated with crowd simulation software to allow managers of congested stations to manage peak periods as well as emergencies in a more efficient way; New communications technologies will replace traditional ticket sales and allow both users and operators to have real-time data at their fingertips. Passengers will be directed to their trains on real-time data.
TD3.11.2 Standardisation and Prototypes for small stations	Confusion and lack of clarity within the industry regarding station products and materials that are safe and affordable to use and maintain. Standardisation of designs is not prevalent and sometimes does not even reflect local climatic and operational requirements.	Clear guidance on products and materials suited to stations in differing scenarios to aid optimised selection and specification.
TD3.11.3 Platform to Train Accessibility	Majority of existing platforms cater for a variety of rolling stock with varying floor heights. Curvature of existing platforms creates gaps between train and platform. Reconstruction of existing platforms is very expensive and cannot be justified where rolling stock is variable.	Solutions that will allow safe and inclusive access to the train and will not be too demanding on maintenance and nor should they increase the dwell time of the train significantly.
TD3.11.4 Emergencies Risk Assessment of major stations	Station Managers do not have sufficient data and tools to deal with emergencies and depend very much on personal initiatives of the station staff in such situations. Inconsistent security provisions and lack of best practice sharing.	Element of surprise and unpredictability during emergencies will be countered with strategies and procedures worked out in advance for major stations.



### **Market Uptake**

By the end of the proposed work, the following elements required for rapid market uptake will have been achieved:

- Demonstration of technologies on all tasks up to TRL level 5. Tasks 11.2 and 11.4 will be taken to TRL level 7 and there is also potential for Task 11.3 to be taken to TRL level 6.
- Products and systems that are developed for easy and high quality manufacturing.
- Solutions designed to be simple to operate, easy to maintain, completely interoperable and compatible, allowing for effective and efficient supplier competition.
- Shift2Rail will provide products and systems that have been independently assessed for compliance with European standards and requirements giving confidence to Infrastructure Managers and permitting rapid deployment.
- Shift2Rail will be able to provide evidence for successful system integration of the products greatly helping Infrastructure Managers to gain trust in the innovations and products.
- With the infrastructure managers as part of Shift2Rail the products will come with a pedigree of end users needs having been properly addressed

The Shift2Rail development will stimulate new product introduction, allow for the supply chain to manage the risk better and allow longer warranties to be issues in line with the construction industry thereby greatly helping product acceptance and deployment.



**Potential Technical Limitations/barriers**

The following Technical limitations, barriers and risks are foreseen for the TD.

	Limitations or Risks	Mitigations
TD3.11.1 Crowd Management and Revenue Protection in large stations	This work-stream will be exploring something completely innovative and untested in the rail environment.	The implementation would have to be gradual so that passengers are allowed a gradual transition from current payment and control methods to the new ones
TD3.11.4 Emergencies Risk Assessment of major stations	The typology of major stations can be very varied and strategies may have to differ from one station to another.	European survey of major station typologies required at the outset. A clear definition of the type of station to be addressed with exclusions clearly identified from the outset.
	The simulation of an emergency in a major station would involve too much risk making a real life simulation not desirable.	The emergency simulations will be virtual.
TD3.11.2 Standardisation and Prototypes for small stations	It may be difficult to achieve an alignment of requirements that covers the whole of the continent for environmental and legal, as well as operational reasons.	The concepts should allow flexibility and modularity to facilitate accommodating local variations.
TD3.11.3 Platform to Train Accessibility	The variety of existing train and platform configurations will exclude a universal solution for the problem.	A variety of measures adapted to a range of situations.
	National conditions and priorities are likely to influence the preferred solutions.	European wide national survey required at outset to establish clear overall objectives.
TD3.11.4 Emergencies Risk Assessment of major stations	The typology of major stations can be very varied and strategies may have to differ from one station to another.	European survey of major station typologies required at the outset. A clear definition of the type of station to be addressed with exclusions clearly identified from the outset.
	The simulation of an emergency in a major station would involve too much risk making a real life simulation not desirable.	The emergency simulations will be virtual.

### References to existing EU funded research projects

Potential synergies can be found with the following EU-funded research projects:

Acronym (EC Reference)	Description of Project
<b>SECUR-ED</b>	Creation of a global improvement in European mass transportation security through the development of packaged modular solutions
<b>PROTECTRAIL</b>	Development of integrated mission oriented solution asset specific threats
<b>CAPACITY4RAIL</b> (GA 605650)	Research work on infrastructure, train dispatching and timetable planning and monitoring. Recommendations for Open-Source and Open-Interface for advanced railway monitoring applications

### **3.5.11.3. Specific Demonstration activities and contribution to ITDs/SPDs**

#### Technology Demonstrators

The two TDs concerned with improving capacity and security in large stations (TD3.11.1 and TD3.11.4) would have interaction with IP4 and could be combined into an ITD at a major European station. This would be relevant to any SPD involving passenger rail (High Speed, Regional or Suburban).

**Figure 94: Relationship of TD3.11 with other TDs.**

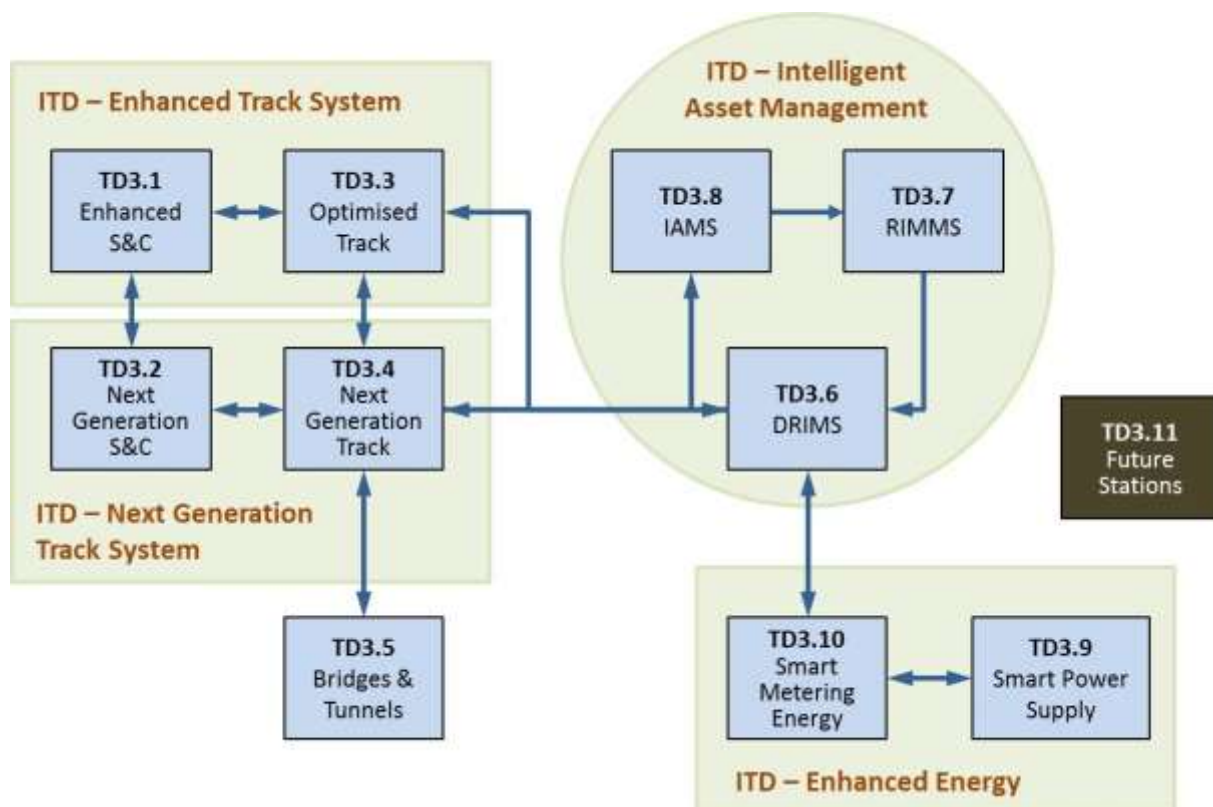



TD3.11.4 will also interact with the SECUR-ED initiative.

The TD.11.2 will be demonstrated by identification and testing of suitable components and products. The ITD of a minor station prototype would be an appropriate way of a combined demonstration of the individual elements (walls, floor, roof etc.).

The TD.11.3 will interact with IP1.6. This would be relevant to any SPD involving passenger rail (High Speed, Regional or Suburban).

	TD3.11.1	TD3.11.2	TD3.11.3	TD3.11.4
TRL level	5	5 to 7	5	7
Internal links	TD3.11.4			TD3.11.1
IPD links	TD4		TD1.6	TD4
External links				SECUR-ED
Station Type	Large	Small	All	Large
High Speed Rail	Relevant		relevant	relevant
Regional Rail	Relevant	relevant	relevant	relevant
Suburban Rail	Relevant	relevant	relevant	relevant

### **3.5.11.4. Impact of the Future Stations Demonstrator**

#### **Description of Benefits**

The following strategic benefits are to be expected from the implementation of the TD results and discoveries is given.

#### *TD3.11.1 Crowd Management and Revenue Protection in large stations*

New technologies that eliminate the need for ticket gates and could allow an increase in the capacity of stations to handle large crowds are potentially a step change in capacity management. Security implications will be carefully considered to create a balanced solution

This research area is not expected to affect any legislation or TSIs.

#### *TD3.11.2 Standardisation and Prototypes for small stations*

The research will help in establishing more sustainable materials and design in railway stations. It is not expected to be affected by the TSIs and will ensure compliance with them.

This research area is not expected to affect any legislation or TSIs.

#### *TD3.11.3 Platform to Train Accessibility*













This research is directly concerned with difficulties in implementing the PRM TSI in existing stations and it is possible that recommendations may result for new TSIs concerning rolling stock making trains more accessible as well as less hazardous.

#### TD3.11.4 *Emergencies Risk Assessment of major stations*

The management of stations using the aid of pedestrian flow modelling will improve the ability of the station managers to respond to overcrowding and other emergency conditions. This activity will have to be coordinated locally and agreed with the local or national security organisations. This research will encourage better means for dealing with security threats on a European level.

#### **Technical impact**

The research and innovation in TD3.11 will have the following contributions to the three specific Shift2Rail global targets:

Impact Type	Shift2Rail Impact	Contribution to KPIs (large spot = high contribution)			
		TD3.11.1	TD3.11.2	TD3.11.3	TD3.11.4
<b>100% Capacity Increase</b>	Improved RAMS performance (Reliability, Availability, Maintainability and Safety) of S&C through enhanced S&C sub-system and component design.				
	Increased network availability through enhanced, predictive maintenance capabilities reducing disturbance of operations.				
	Greater capacity to run more trains				
<b>30% Reduction in LCC</b>	Extended asset operational life through enhanced, whole system design and materials selection.				
	Generates low cost solutions for maintenance and renewals whilst considering 24/7 working and increased safety for workers				
	Whole system design for interoperability and inter-changeability promoting healthy competition within the supply chain.				
<b>50% Increase in Reliability &amp; Punctuality</b>	Improved S&C reliability through continuous monitoring of system degradation enabling timely and focussed maintenance interventions (predictive maintenance).				









#### **Contributions to TSI Standards**

This research area is not expected to affect any legislation or TSIs.

### Strategic impact

The strategic outcomes of TD3.11 are foreseen to have the following estimate of benefits in the following Shift2Rail KPIs:

Impact type	Shift2Rail Impact	Contribution to KPIs (large spot = high contribution)			
		TD3.11.1	TD3.11.2	TD3.11.3	TD3.11.4
<b>Support the competitiveness of the EU industry</b>	<ul style="list-style-type: none"> <li>Global technological leadership supported by a combination of innovation and technical standards, setting an effective advantage for the European industry.               <ul style="list-style-type: none"> <li>An example of industry benefit is the development in close collaboration with infrastructure managers to ensure relevance in solutions</li> <li>Examples of infrastructure manager benefit are (modular and compatible) solutions targeting identified high-priority issues that are validated from a technical, LCC and RAMS-perspective</li> </ul> </li> </ul>				
	<ul style="list-style-type: none"> <li>Increased attractiveness for end users through:               <ul style="list-style-type: none"> <li>Increase in operational reliability through decreased failure rates and maintenance needs</li> <li>reduced costs for rail transports</li> <li>Increased capacity</li> </ul> </li> </ul>				
	<ul style="list-style-type: none"> <li>Establishment of a streamlined, well defined and largely virtualised validation processes that allows for a fast track towards implementation and world-wide marketing</li> </ul>				

Impact type	Shift2Rail Impact	Contribution to KPIs (large spot = high contribution)			
		TD3.11.1	TD3.11.2	TD3.11.3	TD3.11.4
	<ul style="list-style-type: none"> <li>Promotion of modal shift through more reliable and affordable rail travels.</li> <li>Increased societal safety by a modal shift from road (where tens of thousands of Europeans are killed every year), to rail which is of an order of 50–100 times safer.</li> <li>Greening of transport through the modal shift, but also through new more environmental friendly constructions.</li> <li>Achieve single European Rail Area (SERA) through modularisation, standardisation, and a harmonised assessment methodology for innovative solutions.</li> <li>Facilitating interoperability by higher capacity, and more reliable rail operations that enhance the logistic reliability in cross-modal transports.</li> <li>Simplified business processes harmonised assessment methodology for innovative solutions.</li> </ul>				
<b>Degree of maturity of the envisaged solutions</b>	<ul style="list-style-type: none"> <li>Dependent on specific solutions in the tested demonstrators they are envisaged to have a TRL of 5 to 7.</li> </ul>				

### 3.5.11.5. *Implementation of the work programme*

#### Overall approach and methodology

##### TD3.11.1 *Crowd Management and Revenue Protection in large stations*

This work-stream will be managed by Task leader and will follow up in current research being undertaken in this field by the RSSB.

It is foreseen that AM/Open Calls will undertake the following:

- Contribute by developing crowd management tools, which provides real time solutions and mitigation measures to manage crowds on the stations.
- Develop technologies and introduction of ticketless gates, without compromising security requirements of the transport hub (Stations) in relation to TD3.11 .4



*TD3.11.2 Standardisation and Prototypes for small stations*

This work-stream will be led by Task leader with active participation of a European Station Operator.

It is hoped that a small station project being planned by the Station Operator could be developed as a TRL level 7 demonstrator of this work stream.

No AM/Open Calls are foreseen for this activity.

*TD3.11.3 Platform to Train Accessibility*

This work-stream will be led by Task leader with active participation of European Station Operator.

The research will be based on analysing submissions of all member countries (due end of 2016) on how they intend to meet the PRM TSI requirements.

*TD3.11.4 Emergencies Risk Assessment of major stations*

This work-stream will be demonstrated on a Task leader station with active participation of Railways Systems Expert.

**High Level Task Breakdown**

Task	Task Name	Task Description	Lighthouse Project Contribution (%/ Budget)
Task 3.11.1	<b>Crowd Management and Revenue Protection in large stations</b>	<ul style="list-style-type: none"> <li>Review new technologies that can be developed to protect revenue in large stations which do not require gated barriers.</li> <li>Engage with a suitable industry supplier to develop an appropriate solution.</li> <li>Test the product in a simulated environment</li> </ul>	n/a
Task 3.11.2	<b>Standardisation and Prototypes for small stations</b>	<ul style="list-style-type: none"> <li>Conduct a survey of European Construction Industry approved products and identify suitable finishes and products for the construction of small stations.</li> <li>Produce a product selection guide based on the above study.</li> <li>Demonstrate the products through integration with a new station project in Europe.</li> </ul>	n/a
Task 3.11.3	<b>Platform to Train Accessibility</b>	<ul style="list-style-type: none"> <li>Conduct a European wide survey of how member countries intend to meet the PRM TSI requirement of accessible platform to train interface (height of train and curving platforms).</li> <li>Collate research on how to resolve the issues and assess the potential solutions.</li> <li>Produce recommendations and demonstrations of how they can work.</li> </ul>	n/a
Task 3.11.4	<b>Emergencies Risk Assessment of major stations</b>	<ul style="list-style-type: none"> <li>Evaluate the security issues on large European stations, considering the different typologies of the stations.</li> <li>Identify a suitable station for a virtual simulation of emergencies and the development of software to analyse the passenger movements and facilitate operations in managing safe evacuation.</li> </ul>	n/a





**3.5.11.6. Planning and budget**

**TD3.11 Gantt Chart**

TD3.11 - FUTURE STATIONS DEMONSTRATOR		2015				2016				2017				2018				2019				2020				2021				2022				2023				2024							
Task	Description	Q1	Q2	Q3	Q4	Q1	Q2	Q3	Q4	Q1	Q2	Q3	Q4	Q1	Q2	Q3	Q4	Q1	Q2	Q3	Q4	Q1	Q2	Q3	Q4	Q1	Q2	Q3	Q4	Q1	Q2	Q3	Q4	Q1	Q2	Q3	Q4	Q1	Q2	Q3	Q4				
3.11.1	Crowd Management and Revenue Protection in large stations																																												
3.11.2	Standardisation and Prototypes for small stations																																												
3.11.3	Platform to Train Accessibility																																												
3.11.4	Emergencies Risk Assessment of major stations																																												

**TD3.11 Budget**

The estimated budget for the TD is around 6.2M €.



## 4. IP4 – IT Solutions for Attractive Railway Services

### 4.1. Context and motivation

A critical environmental challenge of the coming years is the reduction of the carbon footprint, and citizens will be asked to reduce their car usage as much as possible. Thus, one of the effective contributions of Shift2Rail will be to make rail more attractive so as to encourage people to use this mode as one of their preferred choices, rather than the car.

The capacity to offer door-to-door journey, using multiple modes of transport, fostering the use of rail and public modes over private vehicles, will allow a reduction of the number of vehicles circulating, and as a consequence, positive effects are envisaged such as reduction of traffic, emissions, etc.

Currently however, a multimodal journey does not always appear as the best option for a traveller, due to different aspects that the traveller perceives as obstacles and that prevent the user from having an easy and enjoyable journey. Indeed, travellers engaged in a multimodal journey must adjust to different interfaces, devices, conventions, procedures and tools developed over the years by many retailers, operators, and distributors, and are confronted to solutions which are not enough user-friendly.

Besides, different transport modes (air, main line rail, urban rail, buses...) have grown independently at diverse speeds and different periods of time, without any general plan, and are exploited by different operators. Even if there is some level of standardisation within each mode, a passenger travelling over different transport modes is confronted to the lack of interoperability.

This makes multimodality patchy and as a consequence travellers are still victims of the diversity of the market place, and have little control in managing their travel: because of the lack of end to end one stop shop experience, travellers have to manage themselves the context of their search and purchase for their itineraries, by interacting with very different interfaces covering only partial elements of their trip; current ticketing and validation systems across transport modes and operators have great variability in terms of concepts, architectures and equipment: level of services, capability description, booking, pre-paid product versus post-payment, validation media and profile of users vary greatly from a system to another. The consequences are that the citizens must often switch between sites or offices in order to shop, book and pay the components of their intended journey – and must have multiple tickets to validate through the multimodal journey.

On top of this, there is little in-trip assistance for travellers when navigating transport nodes, confronting service disruption, or receiving up to date status on the subsequent legs of their journey.

This is why the European Commission in the White Paper for Transport 2011 identified this challenge as one of the 10 main goals of the coming years: “By 2020, establish the framework for a European multimodal transport information, management and payment system”.

With this overall goal in mind, there are a number of specific challenges that will need to be taken into consideration in the context of IP4.



### **Access to data**

Amongst the challenges in the market place for the rail, an important one is certainly the access to data: timetables, prices, links with other modes, specific information related to traveller preferences, real time information on the journey, etc.

Data standards already exist in the rail sector: TAP TSI, SIRI (Service Interface for Real Time Information), amongst others. But different ones exist for other sectors (e.g. air).

Because the IP4 objective is to facilitate multi-modal transport, we need to define bridges between these standards. This is done by the interoperability framework (a semantic web of transportation), which offers ways to automate at the framework level (and not at the application level) the translation between standards.

Access to data is not only a technical problem, but also a business problem: how to convince the operators to publish their data, what are the guarantees on the usage made by third parties, who is responsible in front of the final user for the quality and reliability of provided information. The market uptake of the IP4 technical enabler will exist only if data are available to support the market growth.

The first interest of an operator to use the interoperability framework is to become visible by an open-ended world of service resources on the market place, which is a condition for business increase. Moreover, the technologies used in IP4 are giving some guarantees which can ease the market uptake. The interoperability framework, using semantic technologies, is proposing a more controlled environment (data access, usage control) than a complete “open data” approach. Annotation contributes to protecting data, as it permits to fix commercial conditions, or to define specific mechanisms to enforce access control. Moreover, the interoperability framework overcomes the cost issue related to data format at application level but also when publishing the data. These innovative technologies should convince the operators to publish more easily their data. Although IP4 places the traveller at the centre and takes his comfort as main target, by increasing the attractiveness of the rail and other collective modes we also expect to increase the number of users of these modes, and therefore, improve operators' business. This means that by joining the IP4 transport ecosystem, operators will benefit from multiple advantages such as making information about their services more accessible to users, or getting valuable insight from travellers' behaviour. Therefore, we expect that these advantages motivate operators and service providers to make accessible their information and services in order to increase the number of clients and optimize their performance thanks to the tools available in the IP4 ecosystem.

### **Data privacy, security of personal and financial data:**

Another challenge stems from the security issue. Personal information (the preferences) are stored in the travel companion wallet, and also some expensive assets (long range airplane entitlements tokens for instance) for which protection and resilience towards cyber-attack must be guaranteed. The possibility offered to retailers and operators to access information in the wallet (e.g. to read preferences) must be carefully controlled, and profiling by the usages must be subject to explicit consent. The security challenge also exists in the “Booking & Ticketing” processes, where financial data are managed (clearance, settlement).

## 4.2. Objectives of the IP and expected results

The goal of IP4 is to answer these challenges by proposing more innovative, attractive and end-users oriented rail services, and by providing a general framework for multimodal transport.

IP4 will place the traveller back at the centre of the transport infrastructure and will introduce innovative technologies in the transport domain, allowing the development of seamless travel solutions by the multimodal information management and payment ecosystem.

To support modal shift, rail must become more attractive for the end user; this will come with additional comfort and a better reliability of the rail system, but also by simplifying all the stages of the passenger journey and by ensuring a better connection with his daily life.

The target is to transform, the European citizen's global travel interactions into a fully integrated and customised experience, rendering the entire European transportation system a natural extension of citizens work and leisure environments, across all transport modes, local and long-distance.

In particular, IP4 will lead to a dramatic increase in rail attractiveness, generating sufficient growth in demand to support a major shift to rail through:

- A seamless travel experience: a complete multimodal travel offer, connecting the first and last mile to long distance journeys combining air, rail, coach and other modes of transport or services;
- A seamless access to all travel services: the travel experience will be totally enhanced through the integration of a wealth of travel services supported by innovative Digital technologies

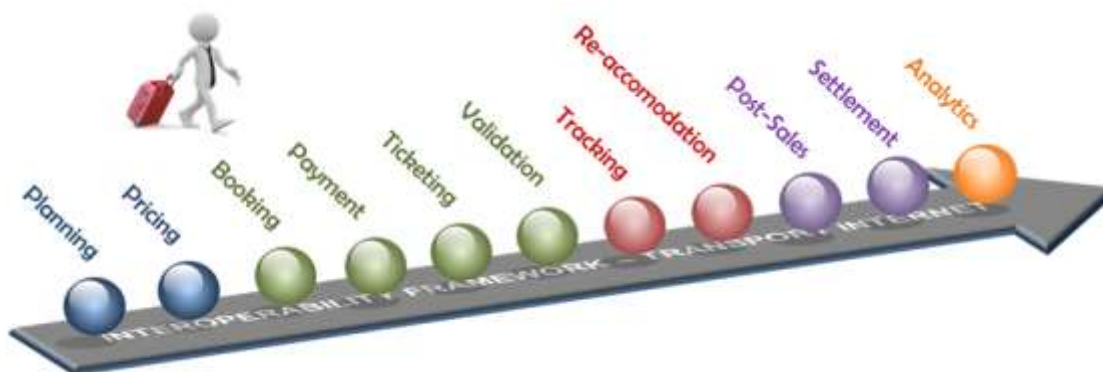

This core objective of extended seamlessness will be answered though the introduction of a ground-breaking 'Technical Enabler' driven by two key concepts:

- The travel experience becomes a 'product', with the Traveller placed at the very centre. This user-centric shift ensures that multimodal travel services mask the complexity of the transport system and offer a whole new door to door travelling experience with strong appeal, simplified access and trusted reliability.
- An open published framework will allow unprecedented service interoperability whilst limiting impacts on existing systems, without prerequisites for further centralised standardisation.



Transport industry incumbents and newcomers will discover wide opportunities to provide new services, products and new competitive business models.

The overall strategy for IP4 developments can be summarised as follows:

- IP4 will not develop a “one size fits all” solution (or set of solutions), but a 'Market Place', where all transport stakeholders will find an open-ended world of data and service resources, which can be combined for improved services. IP4 is not about imposing solutions, it is about enabling market players and new entrants.
- Even if IP4 will encourage open data, it will accept any kind of data in any standards, interpreted by the interoperability framework. IP4 provides the mechanisms to access and orchestrate data and processes wherever they happen to be located. IP4 is completely agnostic to whether data and processing is centralised or distributed.
- Only parts of IP4 developments will be open source, but all specifications and interfaces will be open (access free), and every company can use them to develop equivalent (or additional) services. Reference implementations for the key services will be developed using the open specifications, and will be presented as services hosted by the “web of transportation”
- IP4 is completely agnostic to whether products and services are directly or indirectly distributed.
- IP4 will be completely distributed (no centralisation for data, no imposed technology) and modular. IP4 does not mean a centralised data and/or processing centre, or centralised single platform for customers to get their multimodal travel plans and tickets. It’s about facilitating these capabilities everywhere.

The following table summarises the main objectives of IP4 and provides an overview of some of the concrete deliverables that can be expected to result from the activities undertaken in the IP.



**Table 20: Objectives and challenges of IP4**

Objective	Result	Practical (concrete) deliverable
Enhance the (capacity/) User demand of the European Rail System	Provide a “one-stop shop” to the customer (able to handle any mobility query) and give visibility to all accessible trips	“Travel Shopping” will propose specifications and reference implementation designed to be scalable to all transport modes, all operators and supports shopping over all types of distribution channel (direct, indirect, online, offline etc.)
	Provide a unified access to ticketing services for all transport modes, regardless of their location, access method or format, validation process.	“Booking & Ticketing” will provide specifications and reference implementation covering 100% “standard” entitlements (air, train, long-distance bus, daily/weekly/ passes, origin-destination/zonal, etc.)
	Provide a personal “guardian angel” which gives access to all information, additional services, and simplify the user travel experience	Reference implementation of a “Travel companion” with innovative human machine interfaces.
	Better adaptation between supply and demand	“Business analytics” will provide all the tools to refine the supply of the operators and better satisfy the users
Consolidate the (reliability/) Quality of services	Increase the resilience of the rail system for the passengers	The “Trip tracker” will provide real-time information on the current trip legs, including any mean to adapt the journey and re-accommodate part of the trip if needed
Improve on Life Cycle Costs / Competitiveness	Foster an extended competitive market of advanced applications and interoperability products and services	Open specifications, detailed open interfaces, and access to the open interoperability framework will offer to any European travel industry player the tools to develop competitive and smart services, based on the framework defined in IP4.  Amount and heterogeneity of data and improved “Business analytics” process allow more efficient operations and use of resources.



### **KPIs for IP4:**

It is worth noting that IP4 will not use the same KPIs as the other IPs (capacity, reliability, LCC). The increase of passengers and therefore the IP4 activities aiming at improving the attractiveness of the rail sector are a pre-requisite: we need additional capacity only if we are able to attract more passengers.

The increase of passengers is a major factor in term of competitiveness for the rail transport sector. Additionally, at the same time it is the key condition for a significant and large modal shift from private cars to rail.

In the final analysis, one of the most relevant indicators for comparison of alternative modes is the total cost (LCC) per occupied seat per kilometre. The Shift2Rail initiative seeks to increase the capacity for a given infrastructure, by increasing the number of trains (control command), while increasing the number of seats per train (rolling stock), and reducing the life cycle cost (of the rolling stock and infrastructure) all constitute major steps. It is also essential however to increase the number of passengers (occupied seats) by providing them with better reliability and quality of service, including seamless travel.

IP4 proposes the following KPIs to measure the influence of the IP4 TDs:

- Increase the multimodal usage and the total number of passengers;
- Increase the usage of cross-border train services
- Quality of services: facilitate the travel planning for users and reduce the time spent in planning travel; less time spent searching and booking tickets, less time and better user experience in waiting for the transport mode and rearranging the journey;
- Costs: increase the overall occupancy rate with limitation of peak and off peak periods.

Below are some first proposals to quantify these KPIs (to be refined and validated with the CCA activities in charge of the KPIs for S2R)

- Shopping: in case of multimodal journey, IP4 will reduce the look to book ratio by 60%, and increase the conversion rate by 200%
- The number of international rail ticket sales is increased by 30%
- The time to find an end to end journey proposal transformed in a booking is reduced by 3
- Abandonment by users, in the overall shopping effort for multimodal travels is reduced by 4
- Traveller satisfaction increased within the journey (x4 overall) thanks to:
  - Customisation (preferences)
  - Content of information (including real time)
  - Innovative presentation (adaptation to the user and to the context)



- Accuracy of re-routing solutions (in case of disruption)
- Optimisation of the occupancy rate of the trains (by giving accurate information to the operators on the traveller demand): LCC reduction 3%.

**Strategic and Business Impacts:**

The ecosystem's economics of travel service providers will benefit by the elimination of the need for any common and scheduled 'platform' development. By supporting full semantic interoperability of interchangeable and loosely coupled tools, data and services, within a distributed "web of transportation", multiple concurrent implementations can be developed independently by specialist suppliers and co-exist competitively. This will apply downward market pressure to the cost of sourcing tools and technologies for travellers, retailers and operators, while allowing them to retain full control of the choice of business models through which to consume or provide value.

Through the implementation of specific use cases, the traveller, the services retailer and transport operator will perceive beneficial impacts:

- Passengers' services: the travel companion will give easy access to IT services adapted to passengers "profile" exposed by their preferences. Thanks to the connection between the preferences and the geo-localisation of the person, many innovative IT solutions can be developed covering all aspects of the social life (culture, merchandising, etc.).
- The market of transport services (shopping, ticketing but also services related to guidance) will be opened thanks to the interoperability framework. The fact that the heterogeneity of the transport market is now masked by the interoperability layer will decrease the investment costs for advanced IT solutions, and will open a new competitive market.





### 4.3. Past and ongoing European & national research projects

The proposed approach will consider relevant major projects and initiatives running concurrently (see table below). The identified liaison will allow the digestion of external innovations while promoting the key concepts of Shift2Rail IP4 towards other groups:

Major Projects	Valuable outputs for IP4	Liaison
TAP-TSI	A common denominator set of standards for the rail industry designed to establish base-line standards for cross-border rail services, including reference data for location codes and company codes. This legislation is legal binding in the EU.	AMADEUS, THALES
Full Service Model (FSM)	Door-to-door rail products & services distribution across all distribution channels (domestic & cross-border).	AMADEUS,
All Ways Travelling (AWT)	Study and POCs suggesting that integration of long distance and local transport capabilities can be achieved without integration of 'standards'.	AMADEUS, THALES,
Smart Ticketing Alliance (STA)	Relevant trust schemes and specifications defining urban needs for cross-border ticketing technologies.	<i>IT2RAIL members</i>
EU-SPIRIT	'EU-Spirit' is a cross-border and Internet-based travel information service for customers of public transport.	HACON
MOBIWALLET	Integrate different payment means for multiple transport modes, fostering a seamless travel and providing other added-value services to improve intermodal journeys.	INDRA
IT2RAIL	IT2RAIL is the Shift2Rail light-house project initiating IP4 activities	THALES, AMADEUS, INDRA, HACON,

Progress has been made with respect to Intra-Rail sector standardisation epitomised by TAP-TSI Regulation and implementation project together with the objectives of FSM project. With regards to inter-transport mode standardisation, apart from NeTeX/Transmodel CEN technical standard, objectives are arguably difficult to pursue since the pace of evolution of the transport industry outstrips the pace of such efforts. As such, IP4 draws from current or emerging sectorial standards.

IT2RAIL, the Shift2Rail light-house project initiating IP4 activities, will be used as a ramp-up towards Shift2Rail IP4 full capabilities.

### 4.4. Set-up and structure of IP4

#### 4.4.1. Structure of the IP

To achieve its objectives, IP4 will conduct work in the three Research and Innovation areas listed in the Master Plan, which are:

- Technical framework:

Enforcing multi-modal travels in a very diverse environment and with many transport modes is the role of the "Interoperability framework"(TD4.1): the world of transportation service



providers needs to be open-ended, evolves at its own pace, uses multiple data formats and interfaces. Interoperability is positioned at the *semantic* level and defines formal and explicit models of the transportation domain in an open standard machine-readable language that will be exchanged automatically by computers.

All the services related to individual travels and to additional sensors will generate a lot of data which have great value for the operators and the end-users: open-ended, non-centrally coordinated world of networked sensors, devices, social media, services and transactions. It will be the role of “Business Analytics” (TD4.6) to manage those data. Novel “big data” technologies such as “intentional” semantic information (denoting objects by properties rather than by values) will improve the capabilities to analyse distributed and heterogeneous linked data, creating huge possibilities to generate unprecedented insights for all the actors of the ecosystem, and new intelligence for the benefit of operators and travellers.

- Customer experience applications:

It is a key objective to provide travellers a seamless access to all travel services and enhance their travel experience. In IP4, the travel experience becomes the ‘product’ with the traveller placed at the heart of innovative solutions.

The traveller will have full control of the journey thanks to his own personal and secured “Travel Companion” (TD4.5), storing and sharing his personal preferences in a wallet. The Travel Companion gives access to all travel services needed for the journey, shopping and booking, and allows the storage of the rights to travel. At the same time retailers and operators are able to identify and authorize Travel Companion access to their own systems and networks. Through the Travel Companion, the traveller can also monitor his journey in real time. This is done by the “Trip-tracker” (TD4.4) giving in-trip assistance when navigating transport nodes, personalized information (related to preferences stored in the Travel companion), up to date status on the subsequent legs of the journey, and supporting the Traveller in case of disruption, by proposing new travel alternatives with the possibility to book and acquire updated rights to travel.

- Multimodal travel services:

To engage on a multimodal journey, the traveller today must switch between several websites, retailer and ticket offices in order to shop, book, pay, and must have multiple tickets to validate through the journey. The IP4 approach aims to hide this complexity and enable “one-click” shopping and booking/payment and ticketing for complete multimodal itineraries. The “Travel Shopping” (TD4.2) will provide a comprehensive shopping application enabler which combines all modes of transport, all operators, and all geographies and provides a list of customer-relevant trip offers which are all guaranteed available for booking, purchase and ticketing. Our approach will promote the integration of distributed Travel Operator data and the orchestration of services such as expert journey planning. The Interoperability Framework facilitates both aspects by enabling applications based upon different standards or coding lists to communicate meaningfully but with no costly application adaptations.

The “Booking & Ticketing” (TD4.3) will orchestrate multiple but parallel interactions with several booking, payment and ticketing engines, including the all-important roll-back activities should

any single transaction fail in order to eliminate risk. Sustained by the concept of a unique traveller identifier and the Travel Companion wallet – the traveller will have easy access to the complete and integral components of his/her journey, including easy production of the entitlement tokens required for all ticket validation controls encountered 'en route'. The creation of a unified entitlement lifecycle management will radically simplify the traveller's life by abolishing uncertainties associated to 'behind-the-scenes' multiple booking, payment and ticket processes. Although downward compatibility to existing and legacy systems will be possible for operators joining the scheme without modification of existing equipment, our approach will promote new technologies such as NFC (Near Field Communication) and EMV (EuroCard MasterCard and Visa) and smartphone integration.

Although IP4 is organised around Technology Demonstrators (TDs) with clear and non-overlapping objectives, all the inputs are contributing to a specific IP4 Integrated Technical demonstrator (ITD4.7) which is the orchestrator of the TDs developments, and which is providing the system approach to integrate the different TDs results.

#### 4.4.2. Approach within the IP

The overall method is to target a system level “complexity” and “maturity” (scope and TRL), defined through releases at ITD4.7 level, and to identify the functions (at TD level) to achieve this objective.

Common high-level methodologies will be applied to ensure a common approach in the different TDs, leading in turn to consistent Specifications and an overall demonstrator that can be easily integrated. The following diagram summarizes the methodology:

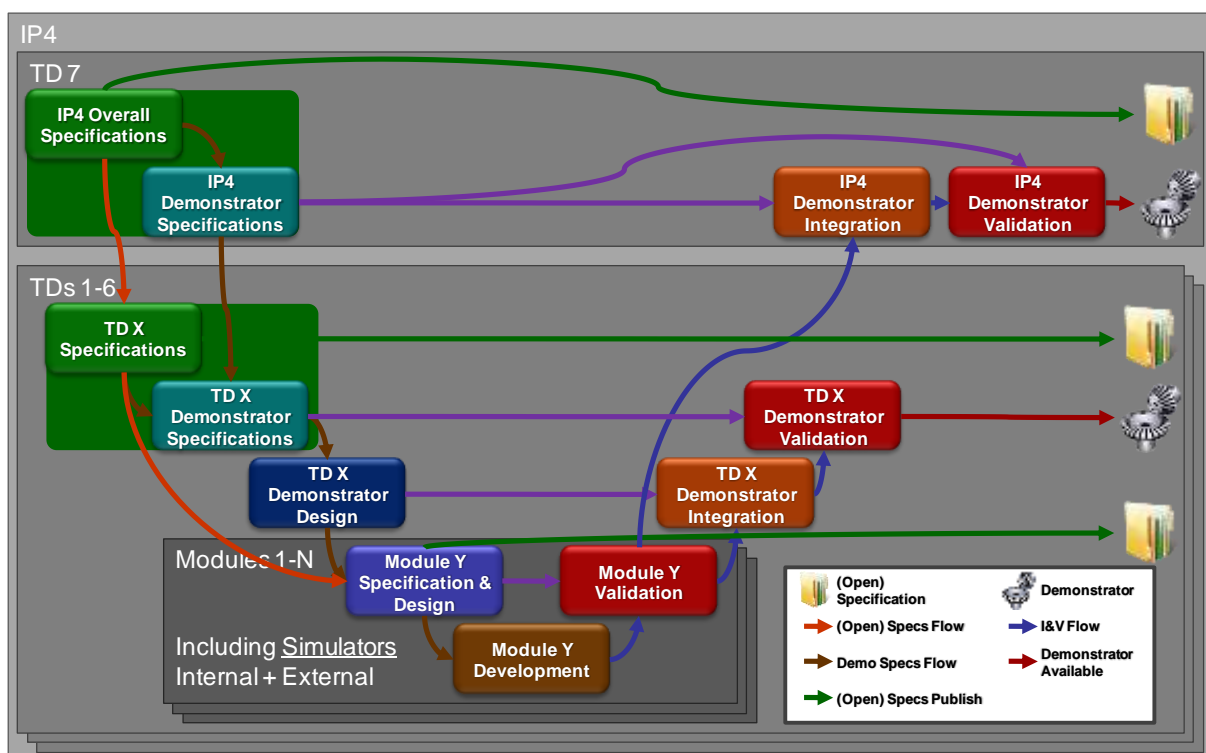



In this diagram, the main focus points are:

- Three levels of specification and design, at the overall IP4 level, at the TD level, and at the module level, all intended to produce consistent open specifications, and guaranteed by a chain of allocation, review and acceptance at each level. This chain of allocation must be supported by actual tasks in all TDs, in ITD 7 for providing the information, controlling the allocation and the interfaces, and in each TD for reviewing it, commenting it, and finally accepting it.
- The inclusion at the IP4 and TD level of specific Demonstrator Specifications, intended as rules for the development, and which include the specificities (e.g. restrictions, specific use cases or locations, etc.) for the actual development of a demonstrator, which will progressively grow to become operational all over Europe.
- The breakdown of each TD into modules, which are the smallest denomination of open specifications.
- The fact that some modules have to cover simulators necessary for the testing of the demonstrators at the TD level or at IP4 level. These modules are simulating the input coming from the other TDs (internal simulators) or from the external world (external simulators), input which are needed for the validation phase.
- Two levels of integration, at the TD level for the TD Demonstrator, and at ITD 7 level for the overall IP4 Demonstrator.
- Three levels of validation: for each TD module, for the TD Demonstrator, and for ITD 7 (acceptance of the overall IP4 demonstrator).

The overall methodology for IP4 will thus be iterative, with releases, on a regular basis and for all TDs, of successive versions of enriched deliverables, from early conceptual prototypes to the final version.

There will be in total 4 releases: the first one is the final deliverable from the IT2RAIL lighthouse H2020 project, which is starting all activities with a reduced complexity and a low TRL (TRL4-5). Then the subsequent releases will 1) increase the maturity (TRL level) of the functions already developed in the previous releases, and 2) introduce new functions with lower maturity (TRL 4).

The objectives is to target with the final release an almost complete set of functionalities answering to the Master plan objectives (see above) and to achieve a maturity level TRL 6 minimum.

As a consequence, all IP4 developments will be regular and developed in parallel in the different TDs, following the 4 system releases as shown in the scheme below:

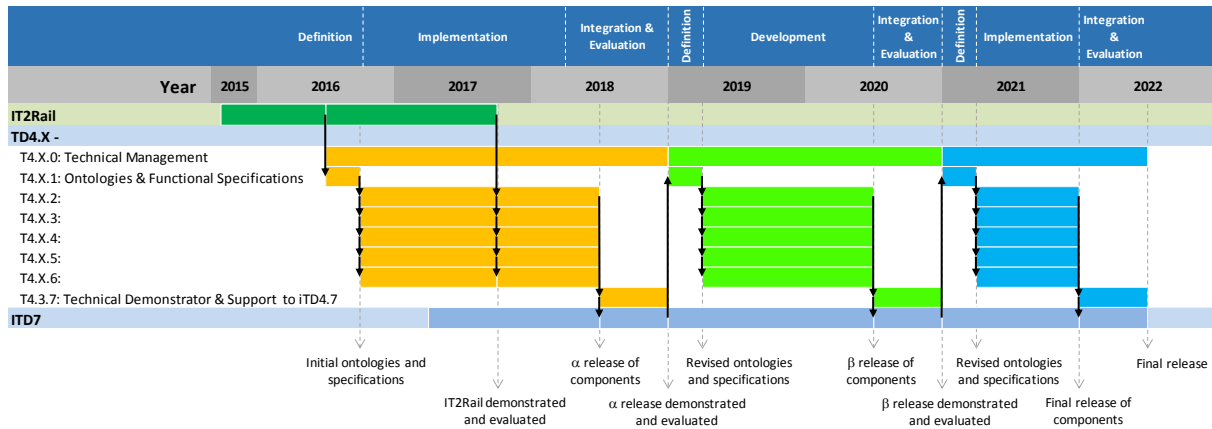

#### 4.4.3. Links to Other IPs, and ITDs

The adherence of IP4 with the other IPs comes from one of its objectives, which is to give to the user real-time information about the traffic for the current and future legs of its journey. The entry point is the trip-tracker, which monitor in real time the complete journey, and must be informed about any disruption, delay, cancellation, and alternatives.

The natural links are therefore the “Traffic Management System” from IP2, several TDs from IP3, related to maintenance or providing alerts coming from the infrastructure, and also the TCMS in IP1, which gives information about the rolling stock status. The information coming from these TDs will be monitored in real-time by the trip-tracker in order to inform the passengers, and propose alternative solutions.

In addition, one of the main purposes of the Business Analytics is to propose an adequate fit between the supply and the demand. Even if this feedback is not given in real time, the information collected is a key driver for the planning of the traffic, and then gives back input to IP3 for the infrastructure management, and IP2 for the traffic management.

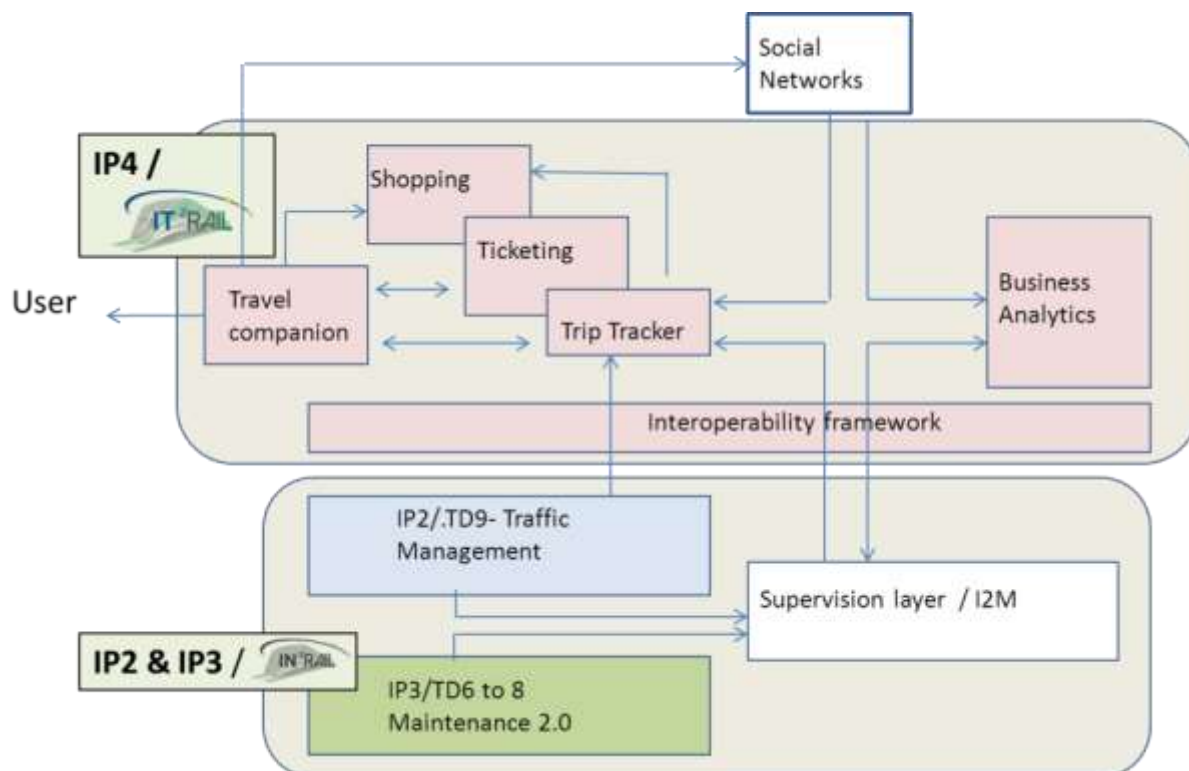

#### 4.4.4. Involvement of Members in activities

Members of IP4 have different profiles:

- Several large industrial companies: major players in the travel planning and shopping, passenger information, and ticketing sectors, they are also well recognized companies in the IT world,
- Some innovative SMEs, mainly present in the TD4.4 and TD4.5 (Trip-tracker and Travel Companion) developing end user experience aspects.
- A major European Rail Infrastructure manager who will provide data through an Open Data Link, and will support the development of specifications.

There are no Urban operators within the current membership of IP4, but several Urban Public Transport Operators are partners of the Shift2Rail lighthouse project 'IT2RAIL', and are willing to support IP4 activities through the IP4 "Users (business) requirements and implementation group" (not yet operational but planned in the S2R governance). The expertise of other S2R members could also help in this respect to fill the gap.

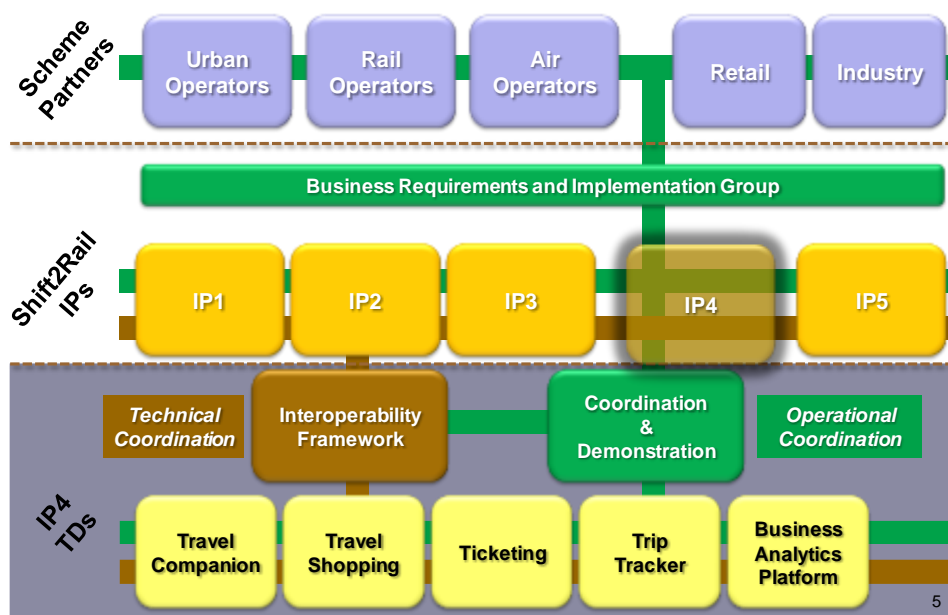

IP4 will need several open calls to complete members' technical activities, and specifically:

- On the technical framework, Research Centres will contribute to:
  - Advanced semantic technologies, big data and linked data
  - Cyber security (some specific tasks)
  - Algorithms for business analytics: prediction, correlation, etc...
- On the User experience aspect, additional expertise will be requested to cover:
  - New HMIs,
  - Indoor location
  - Information filtering from social network, etc...
- On the general governance of such large scale distributed framework, looking at the best ways to promote and maintain it, and to foster its acceptance by the sector.

## 4.5. The Technical Demonstrators of IP4

### 4.5.1. TD4.1 Interoperability Framework

#### 4.5.1.1. Concept and objectives of the Interoperability Framework Demonstrator

The aim of this proposed TD is to enable a complete transformation of the European Transportation ecosystem into a global services and data market place, liberated from technological barriers where actors and business models will be able to emerge and prosper for the benefit of European Travelers.

This TD will address some of the fundamental obstacles currently impeding the deployment of true multimodal ICT systems such as:

- The multitude of data formats across modes and services
- The absence of connectivity standards for ICT systems across modes and actors
- Low availability of good quality data, including real-time data
- High integration costs due to non-interoperable ICT systems
- Reluctance to sharing data and services from actors benefiting from the current fragmentation
- Lack of innovative SMEs due to high upfront investment costs and complex contractual setup

The “Interoperability Framework” should provide technical interoperability by enabling the creation of an open “Web of Transportation”: a shared distributed database of transportation data built according to internet technologies. Linked data principles and supported by semantic web will be considered, besides ultimate advances in big data technology for the multi-formats data management. It aims to provide a shared, fully described and machine readable abstraction (ontologies) of transportation data and services provided and consumed by information systems independently from their internal organisation and representation.

**Figure: IP4 Transport Ecosystem**

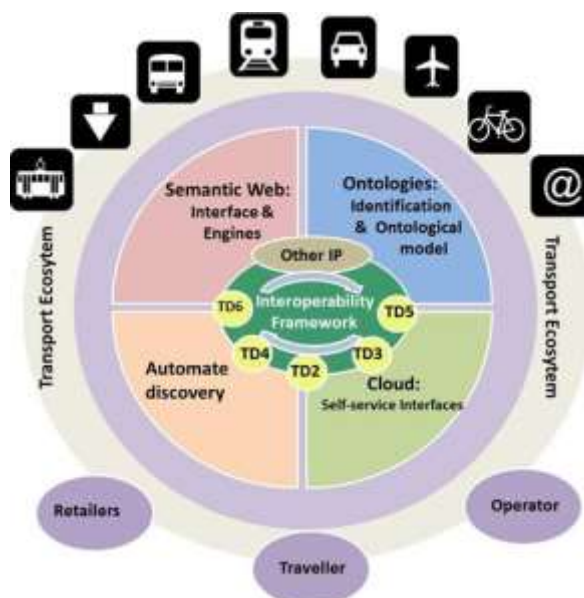

Based on these needs, it is possible to identify the following objectives which contribute to an implementation of the Interoperability Framework, in which business applications are rendered interoperable through the unified, machine-readable view of the Travel and Transportation domain realized as the web of transportation things.



Objective	Result	Practical Deliverable
Share and distribute Travel and Transportation domain knowledge to facilitate automation of interoperability	Explicit representation of the Travel and Transportation domain's concepts, relationships and constraints in a formal computer-readable language that can be stored, shared, and serialized over the network through open web standards.	Machine readable Travel and Transportation <i>Vocabulary</i> stored in repository on the web
Provide business applications with a uniform view of all available data and service resources, regardless of their location, access method or format.	Automation of discovery, harmonisation, composition and linking of any relevant data or service resource anywhere on the network, including legacy or external systems. Construction, maintenance and extension of a web based global space of Travel and Transportation data and service descriptions that can be queried and on which <i>inferencing</i> can be performed by computers, using <i>Linked Data / Linked Services</i> principles ( <i>web of transportation things</i> )	<i>Semantic annotations</i> using the terms of the <i>vocabulary</i> on data and service resources. Intelligent data and web service management services to automate querying, <i>inferencing</i> and linking data and service descriptions. Globally computer readable accessible registry of intelligent data and web service management services
Allow multiple independent implementations and concurrent deployment of multiple instances	Interoperability Framework is an open specification based on open <i>semantic web</i> standards using <i>Linked Data / Linked Services</i> principles, with no predefined architecture and no mandatory centralized components	TD1 as one demonstrator implementation of open specification
Foster an extended competitive market of advanced Customer experience applications and Interoperability products and services	Open specification of the Interoperability Framework is submitted to standardisation process	Technical Interoperability Specifications

The fulfillment of these objectives will contribute to reach the objectives of the Master Plan, specially:

- Travellers and service providers are shielded from fragmentation of services, modes and geographies. This improves traveller experience as well as improve providers decision making, allowing the provision of **improved services and customer quality**
- APIs, open architecture and standards will **reduce development and integration costs** of legacy systems and new systems/actors.
- Harmonised approach to transport services and simplified and fairer access to Transportation ecosystem for newcomers including SMEs, allowing the deployment of **simplified business processes**



- Semantic approach and respect of standards will guarantee technical **interoperability** and removal of open points.

#### 4.5.1.2. Technical ambition of the Interoperability Framework Demonstrator

The TD4.1 will take into account previous EU initiatives that contribute to the applicability of semantic web technology to assure interoperability. A summary is reported in the following table:

<b>SOFIA Artemis project (2009-2011)</b>	Smart Objects For Intelligent Applications, implementation of the semantic model Smart-M3. Main goal of the SOFIA project is to make "information" available for smart services and systems connecting them each other and creating new information ecosystems.
<b>InteGRail FP6 project (2005-2009)</b>	Holistic, coherent information system, integrating the major railway sub-systems, in order to achieve higher levels of performance of the railway system in terms of capacity, average speed and punctuality, safety and optimised usage of resources.
<b>Crystal Artemis project (2013-2016)</b>	Takes up research results of previous projects in the field of Reference Technology Platform (RTP) and Interoperability Specification (IOS) (e.g. CESAR, MBAT ...) and enhances and matures them with the clear aim of industrialisation take-up. Will allow loosely coupled tools to share and interlink their data based on standardized and open Web technologies that enable common interoperability among various life cycle domains. This reduces the complexity of the entire integration process significantly.
<b>Arrowhead Artemis project (2013-2017)</b>	Address efficiency and flexibility at the global scale by means of collaborative automation for five application verticals. That means production (manufacturing, process, energy), smart buildings and infrastructures, electro-mobility and virtual market of energy.
<b>ONTIME FP7 project (2011-2014)</b>	New methods and processes to help maximize the available capacity on the European railway network and to decrease overall delays in order to both increase customer satisfaction and ensure that the railway network can continue to provide a dependable, resilient and green alternative to other modes of transport. In the project, specific emphasis will be placed on approaches for alleviating congestion at bottlenecks.
<b>IoT-A FP7 project (2010-2013)</b>	Internet-of-Things Architecture, architectural reference model together with the definition of an initial set of key building blocks. Together they are envisioned as foundations for fostering the emerging Internet of Things. Using an experimental paradigm, IoT-A combined top-down reasoning about architectural principles and design guidelines with simulation and prototyping in exploring the technical consequences of architectural design choices.
<b>IoE Artemis project (2011-2014)</b>	Integrated dynamic network infrastructure based on standard and interoperable communication protocols that interconnect the energy network with the Internet allowing units of energy (locally generated, stored, and forwarded) to be dispatched when and where it is needed.
<b>iCore FP7 project (2011-2014)</b>	Cognitive framework comprising three levels of functionality, reusable for various and diverse applications. The levels under consideration are virtual objects, composite virtual objects and functional blocks for representing the user/stakeholder perspectives.
<b>Hydra FP6 project (2007-2010)</b>	Middleware based on a Service-oriented Architecture, to which the underlying communication layer is transparent. Include support for distributed as well as centralized architectures, security and trust, reflective properties and model-driven development of applications.



TD4.1 will take into consideration the EU legislation applying to the rail sector, and specifically the regulation 454/2011 (TAP-TSI), which provides a legal framework of technical specification for the Rail Industry designed to establish base-line standards for rail services and standardized location/company coding, and also other initiatives such as FSM developing door-to-door Rail products & services distribution across all distribution channels (domestic & cross-border).

Taking into account the ontologies and vocabulary defined in them, for which a close collaboration among both parts will be needed. As explained in the introduction of IP4, IT2RAIL, developed with the same group of partners, will set the basis towards the achievement of the objectives of the tasks defined within TD1.

#### **Current major technical limitations:**

Hundreds of interfaces and data format standards in tens of projects have been developed by numerous organisations over the years in an effort to integrate ICT systems in the Rail System in different areas. While progress have been achieved, the effort has not provided expected results, resulting sometimes in the generation of additional ad-hoc solutions adopted by individual organisations and adopted through agreements by a small number of partners.

The essential limiting feature of such approaches is the approach to interoperability adopted in the past, where interoperability has been attacked as matter of describing common formats or codes to describe data items to be exchanged, i.e. by creating and agreeing on formal but purely syntactical descriptions of the data. While this is sufficient for machines to exchange the data, the interpretation of the data as digital representations of business entities, events or facts, i.e. the ‘understanding’ of their ‘meaning’ or *semantics*, is completely lost on computers.

For effective interoperability to occur purely through common data formats, in other words, a huge amount of cognitive effort is required to understand the underlying semantics, i.e. the interpretation, context, meaning, intention, assumptions and preferences associated with exchanged syntactic descriptions of relevant concepts and facts. In the lack of a formal, explicit, machine computable expression of semantics, interpretation must be shared by analysis first and then pre-programmed and verified in the application logic.

The problem of currently on-going implementations in the Railway domain is that each stakeholder is focused on a specific problem and there is no common underlying platform, flexible and scalable enough, which can ensure an evolution of the system to cover additional needs.

On the other hand, while the need for ‘common’ basis, languages and scalable architectures is recognized by all, the current technological and methodological approach to reach such commonality, based on standardizing all necessary data elements syntactically, generate even worse problems that they aim to solve:

1. They tend to contain both the scope of interoperability and the number of participating Companies to ‘manageable’ dimensions, keeping both small with respect to the size of the potential market of Consumers and Suppliers alike.



2. Even with reduced dimensions, reaching commonality takes very long time, as has been the case with the technically successful ERTMS standard, incompatible with keeping pace, let alone anticipate, technology and market evolution,
3. The small ‘manageable’ scope of such efforts are not incentives for large and capable technology innovators and providers to join in the effort and provide acceleration factors to the process, such as their own research and development, standards and industrialisation capabilities
4. Most initiatives are initiated by Regulator activity as the current technology base of “commonality” requires a very high threshold of adopters for market forces to operate.

These factors limit the extent of a possible competitive market of interoperable solution providers, therefore limiting the reach of interoperability and preventing significant sourcing costs reductions.

Innovation for an attractive seamless Railway is therefore **required in two directions simultaneously**:

1. In the technology of interoperability
2. In the approach itself to the problem of an innovative technology of interoperability

The Interoperability Framework addresses these two directions by developing an open and extensible semantic web based standard encapsulating interoperability problems and removing them from the ICT assets business logic.

#### **Technical ambition of the TD4.1**

The main ambition of TD4.1 is the provision of the Framework, tools and technologies that will allow data exchange among different actors of the transport ecosystem, providing mechanisms to abstract data consumers from the complexity of varied data formats and non-integrated services, facilitating interoperability among systems and the creation of added value services for achieving a seamless multimodal door-to-door experience

The TD1 technical demonstrator will additionally constitute the ‘reference’ implementation of the specification, to be used as a compliance benchmark of alternate implementations developed as commercial products by Vendors. It plans to develop new concept-map where the integration and standardisation are mandatory for building a complete transport ecosystem covering all the stages of the value chain. Taking into account the results of other R&D projects, mentioned before, TD1 will enhance and adapt existing semantic solutions, define a new ontological model, improve user tools and develop new components for the integration. Besides, mechanisms will be provided to ease and automate the publication of new service providers information, ambitioning levels of higher seamless and easiness in the introduction of new actors. In order to reach this ambition:

- Technical framework architecture will be based on the following principles:
  - **Collaborative approach**, as systems produce information into the Interoperability Framework, making it available to others;
  - **Decentralized deployment**: Multitenant, a state-of –the-art approach in cloud computing, allows deployments of distributed cloud systems replicated over a same implementation but executing different use cases. This approach enhances the robustness of the system as key aspects of the deployments are reused, while reduce development costs;

- **Decentralized management:** A semantic middleware, as “orchestrator middleware” makes it possible to coexist independent systems that can interoperate just by exchanging information (publish/subscribe), decentralizing the management of the complete system. This middleware works as a soft integrator layer thanks to the fact that it only requires simple connectors able to understand structured information using common language “semantics”;
  - **Unambiguous semantics:** the common language for the decentralisation of management is defined by “unambiguous semantics”, based on the definition of complete semantic model, using ontologies for the identification of the concepts representing the information. For each transport sector, the “semantics” should support the underpinning legislation and European standards (e.g. for the rail TAP TSI, TRANSMODEL). This language based on semantics is highly flexible and reusable;
  - **Fast Integration** of systems and data through a “Web of Transportation” that guarantees decoupling among systems and eases to expand the model;
  - **Modular**, organized in different logical blocks;
  - **Open Architecture and Service interfaces:** open solutions promote the expansion of the technology and standardisation, and facilitate third parties integration.
- Abstraction and technical interoperability will be provided following an approach based on ontologies and semantic Web. Tools will be provided for integrating and processing the semantic information exchanged, following an approach based on new or existing models such as the *Smart M3 web semantic model* and the use of *brokers*. Architecture tools will be provided, including open modules/components/interfaces to registry and connect elements and standardize the way they interoperate with the IF.

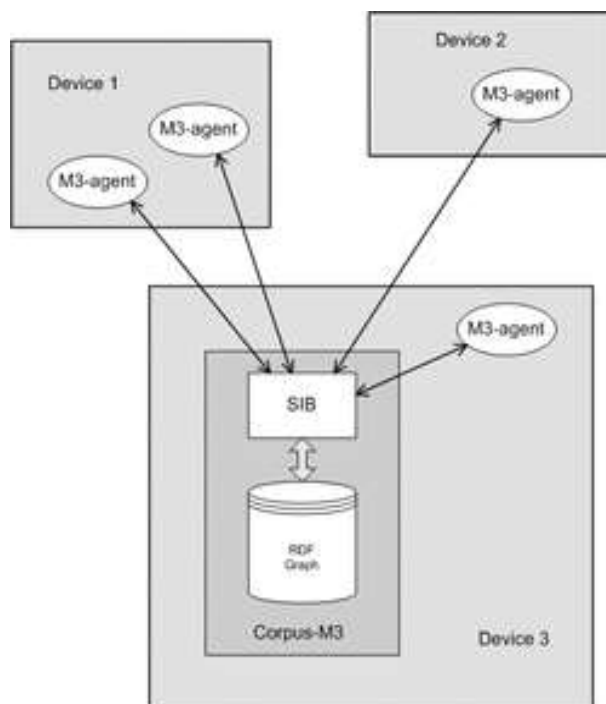
**Figure 95: M3 Web Semantic Model**

- For handling data and resources, Cloud and Big Data concepts will be considered. There are multiple tools that enable us to address Big Data using different approaches, with powerful development communities both for open and commercial software. As long as these tools can solve the requirements identified in S2R Interoperability Framework, they will be analyzed and, where appropriate, included in the implementation. Just to mention some examples with the most diffusion, we can start with the open ecosystem Apache Hadoop, which includes (in BI priority order): the Hadoop Distributed File System (HDFS), MapReduce, Hive, Hbase, Pig, Hive, HBase, HCatalog, Ambari, Mohout, Fume, among others. There also commercial distributions based on that ecosystem such as IBM Cloudera. Additional, there is a fast development different NoSQL databases that allow for some required performance features. As an example, one of the most distributed one, MongoDB, can be obtained for free under GNU's Affero General Public License (AGPL) and is also offered under a commercial license with support. Other examples are Neo4j, AllegroGraph or Dynamo, among others.

#### **4.5.1.3. Specific Demonstration activities and contribution to ITDs/SPDs**

The interoperability framework guarantees technical interoperability of all multimodal services by insulating consumer applications from the task of locating, harmonising and understanding an open-ended world of data, events, and service resources, which are consequently made available 'as a service'. The innovation relies upon semantic web technologies, designed to exploit the establishment of a 'web of transportation things' based on coherent and mapped transportation ontologies. This technology addresses the fragmented state of the market without need for additional centralised standardisation and leverages existing transportation ontologies. It is also open and expandable as data providers can join on voluntary basis by sharing data annotated with terms of the ontology's vocabulary.

The Interoperability Framework is the specification of generic capabilities to allow any compliant rail business application to interoperate. However a specific configuration of the interoperability framework initialized to work in a particular scenario will be required for the end-to-end demonstration scenario to be specified and developed in iTD 7, which will involve the interaction of all other technical demonstration as they realize the scenario's use cases. Task *T4.1.7 Creation of Packaged Resolvers for Interoperability Framework* will be the main task supporting the developments done within TD4.1, allowing to implement the integrated demonstrator. Demonstration of the components provided by TD4.1 will target TRL6 with a prototype demonstration in a relevant environment, simulating operational conditions. The different tasks feed the ITD 4.7, as shown in Figure 96.

Four main releases are expected at system level: IT2RAIL release in October 2017 (end of the project), Alpha release in December 2018, Beta release mid 2020, and a final release early 2022. Functionalities of the releases will be incremental, supporting in each release the new functionalities and needs of the other TDs that use the Interoperability Framework to fulfill their activities.

#### **4.5.1.4. Impact of the Interoperability Framework Demonstrator**

The main benefits that the Interoperability Framework will bring include:

- Enable a complete transformation of the European Transportation ecosystem into a global services and data market place,
- Liberate from technological barriers where actors and business models will be able to emerge and prosper for the benefit of European Travellers.
- To promote the development of large competitive market of independent and autonomous suppliers of business services, applications, devices and systems to the travel and transportation industry by dramatically reducing the overhead, business and financial costs associated with making such services and applications interoperable.
- To promote the development of a large competitive market of independent and autonomous suppliers of interoperability products and services to developers of travel and transportation devices, applications and systems, thus submitting the cost of interoperability to downwards market pressure.

#### **Strategic Impacts:**

- On cost reduction

Enhanced interoperability will allow: decreasing the cost of interoperability of current systems and new ones; decreasing the costs of acquisition of Customer experience systems for Railways Operators; decreasing the costs to Railways Operators of product distribution through Third Parties. Besides, it will foster reusability, harmonizing and superseding some of the current TSIs, eliminating their development and maintenance costs, including in dedicated hardware and system software infrastructure

- Increase revenues



Creating new value chains: Generating additional revenue to Retailers and Railways Operators from richer product offerings and smart services to Customers.

- More Agility

By flexibility of the framework: Decreasing the time-to-market of advanced Customer experience applications

- Better Experience for Customers

Integrating fragmented platforms and systems will contribute to a more attractive Rail System as Customers enjoy continuous access to their personalised journey information systems, passengers treat their journey as a seamless extension of their working or leisure environment, and all freight is traced and tracked in real-time through all stages of transit, whatever the mode. Besides, by aggregating suppliers' systems to the offering, market of specialists suppliers of products and services will be encouraged to be compliant with the Interoperability Framework specification, thus putting additional downwards pressure on the cost of interoperability for Customer experience system developers.

#### 4.5.1.5. Implementation of the work programme

The Interoperable Framework demonstrator handles all interoperability tasks and is therefore the mediator of all interactions across Technical Demonstrators within IP4 and across data assets provided by multiple organisations. As a complex technical foundation for all technical demonstrators, it is important that the strategy for its development be provided with 'built-in' capabilities accommodated to minimize risks to the successful completion of the entire IP4 programme, and for it to be coherent with the consistency and convergence mechanisms designed in the ITD7 technical demonstrator to guarantee overall integration of the IP4 products.

**Figure 96: TD1 tasks structure**

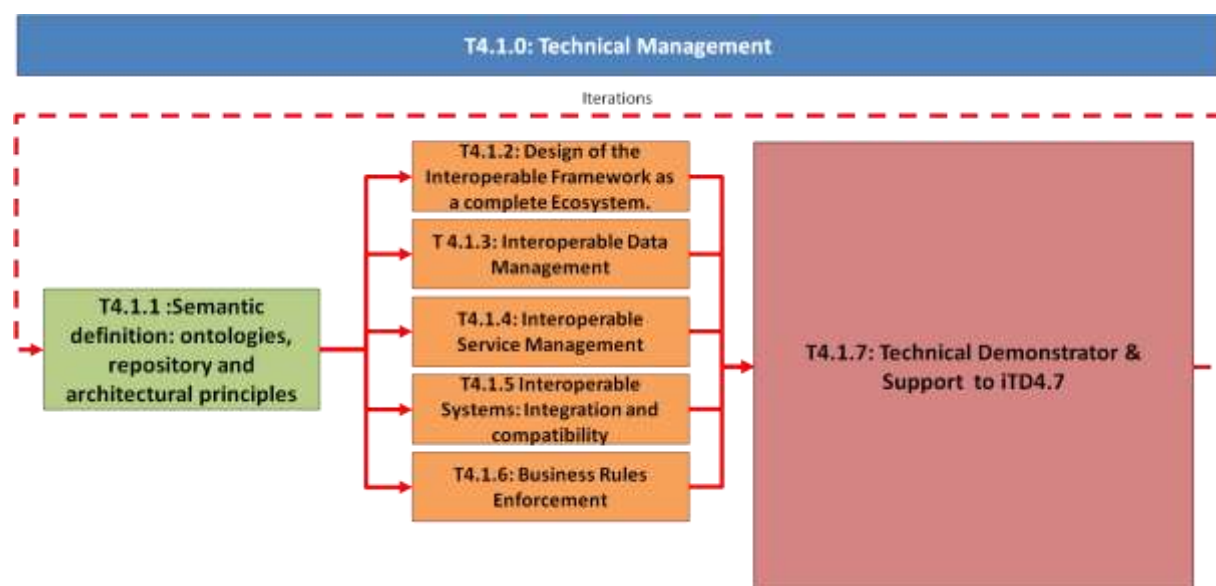



#### **Task 4.1.1 – Semantic definition: ontologies, repository and architectural principles**

Identify, formalize and document requirements and global specifications for interoperability across IP4 TDs' applications. The contributors should collect, document and analyse the semantic approach used as reference paradigm due to its flexibility and high potential in complex ecosystems. This theoretical approach will consider the global definition of a **semantic model** able to support the different ontologies required, therefore this task will support the works done in other TDs regarding the definition of the vocabulary and ontologies of the domain. This task will also define the requirements for the **repository** including configuration meta-data, ontology definitions and data structured. The semantic model defined and its design must be defined into a complete **architecture**, so best practice for architecture will be analyzed. The approach will consider the end-to-end business use cases and engineer specific interoperability requirements required by the execution of multiple interacting services.

The task will select ontologies to generate description artifacts for specific information, resources, or services that the systems offer. The platform generated will identify these artifacts and their equivalences, providing distributed, friendly access to these. By providing context-aware, semantic technologies, the system will improve accuracy, effectiveness, flexibility and reliability. The task will produce a kit to help developers, by providing them with an abstraction from part of the complexity and the possibility to make a cross-platform development (Write Once, Run Anywhere), saving time even to compile the result. In the end, this task will provide the theoretical approach solution and a proof of concept (TRL3) for the interoperability framework. It will be used as input for the following tasks that will enhance and improve the different aspects of the IF beyond TRL3.

**The JU members** will contribute to the specifications and ontologies according to the works they lead in the other task of TD4.1 and to the knowledge of the market and the activities they develop in other TDs.

There is room in for open calls for new contributors especially in the global definition of the semantic model and the ontologies, as well as for the expertise in the tools and technologies available to carry out this task.

#### **Task 4.1.2: Design of the Interoperable Framework as a complete Ecosystem.**

This task will design the complete IF as an ecosystem where different systems can interoperate. Scalability is a main requirement for the design that must be considered in order to ensure the growing of the ecosystem. Bottle neck must be avoided/identified as well as risks and failure points. A risk analysis must be delivered with this task and measures to mitigate them. Technical barriers to achieve the objectives must be identified. The complete IF must analyze besides other aspects like distribution vs centralisation, high availability vs partial availability, real time vs delay, failures tolerance, etc. in accordance with the business requirements. A feasibility analysis must be done along with a benchmark for current solutions that could be considered or discarded.

*There is room in for open calls for new contributors that could address issues such as data availability, ownership, business models, and conditions for a market uptake.*



### **Task 4.1.3: Interoperable Data Management**

This task is concerned with the development of software to provide intelligent data management capabilities necessitated by specific features. “Intelligent” is defined as the ability to locate, access, infer, map, translate, convert, fusion and link data assets distributed anywhere and provided by any organisation based on a formal specification of the domain object’s semantics expressed in a machine-readable vocabulary and underpinned by a formal logical system, irrespective of the object’s representation in any data format and of its serialisation over the communications network.

The data management will consider the semantic model definition as input from the previous task, and will implement solutions to handle with theoretical semantics models like Smart M-3. An information broker will implemented as well as publish and subscription capabilities for the exchange of information. Aspects regarding security, reliability, integrity, access policies or information availability will analyzed during this task, giving recommendations and even requirements for the IF.

The Interoperable Data Management intends to define a common semantic interoperability solution that implements the models and design from previous task platform, shared between very different applications, and thus allowing them to communicate with each other. To do this, the common information storage is expected to be open (when it doesn’t affect privacy, security and business expectations), and independently of the technology used to implement it.

### **Task 4.1.4: Interoperable Service Management**

Develop software components for intelligent management of ontologies (e.g. services routing and transformation) to all IP4 TDs. The contributors should develop software to provide semantic annotation and linking of web services using the ontology vocabulary, and to generate mappings, translations and consistency checks.

Interoperable Service Management builds an ecosystem of interacting objects and service. It should have the capability to self-organize itself, and to provide services and complex data. Interoperable Service Management has to be able to elaborate on basic services and raw data to provide orchestrated services or mash-up data to be used by the external world. This poses many new challenges to face, in terms of dynamicity, scalability, trust, and privacy.

*Open Calls for this task will demand different components for the system, evaluating best options to be implemented in accordance with feasibility and scalability.*

### **Task 4.1.5 Interoperable Systems: Integration and compatibility:**

Develop software components to provide access, fusion, linking and integration of data and services resources provided by legacy and/or external systems (e.g. non IP4 TD specific ITC assets). This should include the development of wrapper software exposing legacy data assets and legacy interfaces as semantically annotated web services in the services registry.

This task will deal with two main problems to be tackled in the creation of a complete ecosystem where different systems can interoperate, including legacy systems: first, how to integrate existing systems, and second, how to build new systems easy to be integrated and fully compatible. To follow an application-driven approach is important because of numerous legacy systems and devices that

will be involved in the services, not being coupled strictly to one device or system but rather to the complete ecosystem.

The advancements simplify the integration and the intercommunication of stand-alone legacy systems including heterogeneous sensors, devices and data. Validated ontology tools will be provided to support homogeneous semantic service description, integrated service discovery and uniform service invocation. The semantic based approaches enable more modular and information sharing based approaches both to selected network management and applications leading to improved characteristics and features.

#### **Task 4.1.6: Business Rules Enforcement**

Develop software components for compliance checking and enforcement services of mutually binding constraints (conditions for accessing resources provided by organisations) between interoperating applications.

Realisation of a dynamic and flexible Interoperability Framework allows its utilisation over different application domains. Multimodal interaction in will apply state of the art interpreters (respective to artificial intelligence components) by defining dynamic rules/configuration for handling multimodal data for modality fusion and fission. The main objective is to define the principles and key concepts as the logical reference architecture of a generic interoperability platform for Business Rules Enforcement services. The principles define what the interoperability is intended for and how the platform is enforced. The primitives that are common to all business define the basic concepts and rules for the interoperability. These concepts and rules together with the reasoning mechanisms form the core services which are adaptable and extensible for the different types of business cases.

*Open Calls for this task will ask for the requested components for compliance with business cases demanding particular business rules. Priority options to be implemented are in order to access and reusability rather than close business rules*

#### **Task 4.1.7: Technical Demonstrator & Support to ITD4.7**

Support, customize and deploy the Interoperability Framework to a specific end-to-end demonstration scenario as defined in IP4 ITD4.7 ('Integrated Demonstrator'). This includes the provision of Packaged Resolvers for the Interoperability Framework. Field trials will give more insight into realistic and daily usage of the Interoperability Framework solutions. Although one does not have control over the circumstances under which end users will use the proposed solutions, the field studies will provide valuable information on the appreciation and contextual use of the solutions. Since field trials should focus on very specific issues that require evaluation in real life settings, the functional system that will be deployed in these trials will have limited functionality compared to the concept demonstrators that are evaluated in a laboratory setting. The package of demonstrators will provide valuable insights for all the previous tasks, based on data collection, interoperability of legacy systems and use of business rules.

*Open calls will be oriented to test the framework in simulated scenarios that could complement the ecosystem of the services giving the possibility to interoperate each other, as well as to the provision of new resolvers that can bring advanced functionalities to the Interoperability Framework.*

### **Contribution to the system releases ITD7:**

The first release is the IT2RAIL release, final deliverable of the IT2RAIL project, scheduled in October 2017. The project proposes a reduced approach to the scale of a specified use case without weakening any of the key concepts of IP4, such as the usage of Semantic Web technologies, and will work on starting to build the Interoperability framework that will be completely settled in the context of the Shift2Rail IP4. The use case presented for IT<sup>2</sup>RAIL works is a selection from all the possible use cases that will be addressed by the Shift2Rail IP4. The use case will be defined as a specific instantiation of our open concepts, and will benefit from a completely scalable architecture fully instantiated in IP4. Among the first specifications and implementation that will be done within IT2RAIL WP1 (equivalent of TD4.1 in S2R), the following can be highlighted:

- Semantic Web Services Registry
- Semantic Discovery Engine
- Semantic Query and Aggregation Engine
- Basic tools and resolvers for the platform

As the initiative evolves and extended functionalities, new approaches, and new transport modes are included on it in the new releases of the several TDs, TD1 developments will be extended to support the new functionalities required and the new information and services included. Besides, the platform will improve its performance through new tools, resolvers and higher automation of processes.

#### **4.5.1.6. Planning and budget**

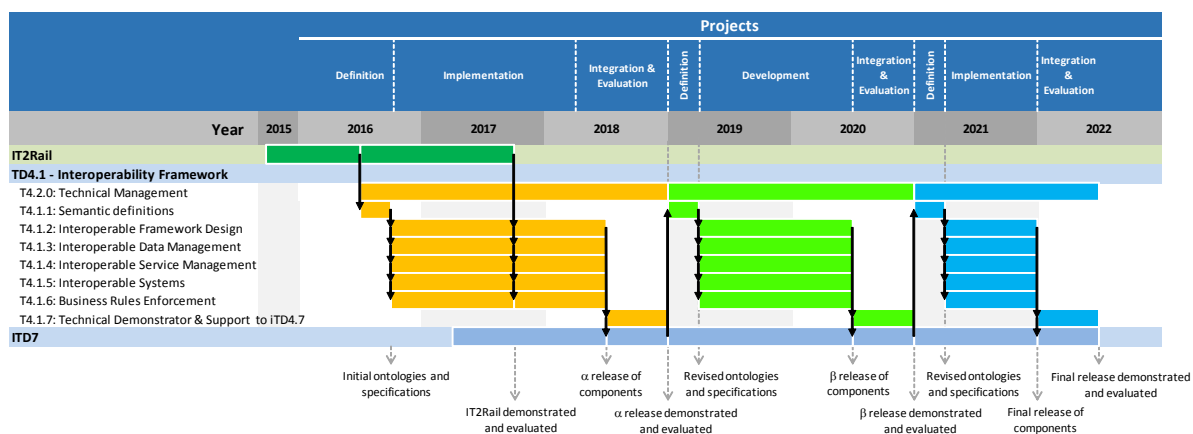

The estimated total budget for this TD4.1 is around 10.4M€. (Including IT2RAIL project)

#### **4.5.2. TD4.2 Travel Shopping**

##### **4.5.2.1. Concept and objectives of the Travel Shopping Demonstrator**

The concept of TD4.2 Travel Shopping is both to enable, and to respond to, an emerging single European multimodal transport market place within a Single European Transport Area (SETA).



The prime characteristic of such a marketplace will be the capability of all travel/transport retail outlets, inside or outside of Europe, to offer door-2-door (D2D) travel solutions for customers' (European residents and visitors) mobility needs and preferences implicating any sort of travel within the SETA.

TD4.2's technical enablement of this capability will be fundamentally 'distribution-channel agnostic', meaning that all retailer operations, whether belonging to 3<sup>rd</sup> parties (indirect) or to specific Transport Undertakings (direct) can choose to avail themselves of the technology. This will provide Transport Undertakings with the liberty to pursue business strategies exploiting the benefits of both direct and indirect channels.

Today's reality of multiple unimodal travel markets means that onus for constructing multimodal travel solutions falls squarely on the shoulders of the customers themselves, mixing and matching transport products and services from a variety of travel retailers, both calculating and risking the feasibility of their combination. Such products and services may be prepaid, purchased 'en route', or even post-paid (as in a number of urban, regional or national smart ticketing systems). As such there is no single travel shopping experience for customers today: each de facto multimodal travel is achieved via multiple shopping experiences before, during, or, indeed, after the trip has completed.

As such, the customer directly confronts the fragmentation of the European travel market. The overwhelming majority of attempts to plan and purchase an entire door-2-door trip, in advance, fail. This is already the case for full rail but cross-border services not always bookable on internet. This is hardly surprising since the fragmentation imposes unacceptable degrees of effort, patience, time-consumption and risk.

The consequences for would-be travelers are manifold: travel intentions may be abandoned; the ease with which travel can be 'shopped' becomes a distorting factor influencing their travel choices; and, frequently, the customer defers travel purchase decision-making for most parts of their trip to the 'en route' shopping window, introducing elements of uncertainty and stress into their actual travel experience.

At macro-level, the corresponding consequences are: that travel markets systematically fail to meet total demand; overall capacity is underutilized; the purchase of segments for pan-European travel tends to favor transport sectors which are more visible via indirect distribution channels; and, travel choices made 'en route' will mitigate against the use of public transport for mid- and last-mile travel (including suburban rail and buses).

Overall, the current environment does not favor Rail which is poorly distributed in indirect channels and whose suburban services are sorely underutilized by customers arriving from outside the city.

This TD looks at how to reduce, radically, the risk and effort of travel shopping, whilst simultaneously facilitating the supply and distribution of comprehensive and combinable transport services. It consequently allows for flexibility and increased choice of business model and distribution strategy for transport undertakings, leading to an optimisation of demand satisfaction, and increased take-up of greener forms of transport. It also addresses lowering the investment barriers, with respect to both market entrants and incumbent transport undertakings, which inhibit exploiting the business

opportunities that commercial partnerships offering smart (intermodal) solutions for recognized or newly discovered passenger flows, can provide.

This analysis answers directly to the following Master Plan objectives:

S2R Objective	TD4.2 Objective(s)	Practical (concrete) Deliverable(s)
Improved reliability	To provide D2D Travel Solutions which are feasible in terms of interconnectivity, and which are available, bookable and purchaseable. At the same time to provide access to historical data on customer queries and Travel Solution selection, enabling Transport Undertakings to better plan, market, and deliver their services, while respecting the passenger rights regulation;	The automatic calculation of minimum connection times between transport services offered by different modes/operators within every returned Travel Solution. Checks on the combinability of transport segments within every returned Travel Solution in terms of availability, pricing, inter-operator ticketing agreements, and payment options. <b>Target:</b> reduce the 'look-to-book' ratio by increasing the rate of conversion of customer queries into travel sales, through a far closer alignment of offers with customer mobility needs and preferences.
Enhanced Capacity	Promote an increase in the proportion of end-to-end travel solutions, which can be purchased and ticketed in advance. This allows for a faster throughput and therefore growth of passenger numbers.	The integration of Transport Undertakings from all modes into the eco-system of products and services which can answer to initial door-2-door mobility queries, ensures that passengers will not clog queues at ATMs or ticket counters, and are able to pass seamlessly through ticket validation gates in order to board their transport. <b>Target:</b> massively increase the number of totally prepaid trips compared with the very low percentage today.
Customer Experience	Support comprehensive access to all operators and modes via 'one-stop' shopping allowing customer preferences to filter out non-compliant Travel Solutions and to sort compliant solutions based upon customer selected attributes.	Provide a comprehensive search capability managing access to distributed transport product/service data and journey planning expertise, driven by customer preferences regarding mode, operator, total travel time, price, carbon footprint, PRM facilities and services, and other auxiliary 'comfort' services (wifi, seat, baggage, special meals etc.). <b>Target:</b> provide lists of travel solutions which are 100% aligned with personal preferences and needs via correct filtering and attachment of relevant attributes to enable comparison shopping
Lower investments costs	Provide global distribution reach through any channel, without the need to invest in costly technology solutions.	The interrogation of transport product owners during the search for building Travel Solutions will be managed by access to a 'converter' (which is provided with the relevant ontology and the correspondingly annotated transport product owner services) so that product owners do not need to invest in different formats and protocols or spend time explaining their own formats and protocols, in order to be distributed. <b>Target:</b> radically reduce the costs of distribution for transport undertakings.



S2R Objective	TD4.2 Objective(s)	Practical (concrete) Deliverable(s)
Reduced operating costs	Ensure customer preferences drive the search (filtering and sorting) for transport products and services.	<p>The travel shopping search architecture is designed to translate customer preferences into requests for additional information e.g. carbon footprint, auxiliary services, PRM facilities and services, which in turn enables transport product owners to respond more effectively to customer demand.</p> <p><b>Target:</b> increase the compatibility of transport product and service offers with customer requirements and needs.</p>
Externalities	Contribute to a greater conversion rate of mobility queries into travel sales, and the identification of carbon footprint per levels at individual transport segment and overall trip.	<p>The combination of comprehensive transport mode/operator choice, and the incorporation of customer preferences (e.g. carbon footprint) throughout the travel shopping process, should increase both the quantity of travel sales as well as the quality in terms of the selection of more environmentally friendly modes, leading to positive impacts on the reduction of costs associated with traffic congestion, pollution, and road accidents.</p> <p><b>Target:</b> major shift to Rail / Public Transport</p>
Respect and adaptation of TSIs	Provide a shopping (customer) and distribution (transport product owner) capability which respects current or emerging TSIs from any mode.	<p>The convertor capability within the travel shopping search process is able to ensure that TSIs and further standards and initiatives (e.g. TAP-TSI, FSM, IATA, NeTeX, IFOPT, STA etc.) are meaningfully translated between players along the supply chain.</p> <p><i>N.B. the convertor depends on inputs from TD1- Interoperability Framework (Travel Expert Resolver) which accesses TD1's ontology repository and annotated service registry.</i></p> <p><b>Target:</b> provide ontological mapping for all known and emerging TSIs</p>
Removal of open points	Use the TD1 Interoperability Framework's semantic web technology features (ontology repository and annotated service registry) to close any open points on interoperability.	<p>The convertor capability within the travel shopping process enables any travel expert (transport product owner) or intermediary travel expert manager/planner, to successfully dialogue with search engines and distributors which feed travel retailing operations within the direct or indirect distribution channels subject to the condition that such travel experts are able to fully annotate their web-services / APIs using the IP4 ontology and to publish them in the TD1 Annotated Services Registry.</p> <p><b>Target:</b> provide ontological mapping for TSI exceptions designed to fill gaps in business coverage</p>



S2R Objective	TD4.2 Objective(s)	Practical (concrete) Deliverable(s)
Improved standardisation	Contribute to 'standardisation' at the meta-level by ensuring that all Travel Shopping terms, objects are formally defined and may be interpreted correctly by machines.	TD2 activities include ensuring that all Travel Shopping terms, key-words and objects, across operators and modes, are defined at the meta-level of the IP4 ontology. This amounts to a meta-standardisation umbrella, which provides the key to automatic decoding and exchange of meanings incorporated by a multiplicity of standards which are correspondingly annotated. <b>Target:</b> produce a fully defined ontology for the Travel Shopping domain which is agreed across all transport modes.
Simplified certification and authorisation	Systematic and automated checking of certification and authorisation information as contained in the annotated services of transport product owners when responding to customer queries mediated via a specific Retail outlet.	Travel shopping will capture authorisation information in connection with transport product owner services as published in the TD1 Annotated Services Registry (schedule, fares, availability) to ensure that requesting retailer operations are not provided with transport / travel data which they are not authorized to receive. <b>Target:</b> provide a cost effective and 'easy to modify' solution for transport undertakings to manipulate the automated control of all conditions pertaining to the distribution of their services.

#### 4.5.2.2. Technical ambition of the Travel Shopping Demonstrator

##### State of the Art

An increasing number of multimodal shopping experiences are available today, but they are limited to certain combinations of modes, operators, distributors or geographical areas. Although this indicates growth in the demand side of the market for multimodal shopping facilities, the state-of-the-art solutions are, today, far from addressing the mobility need in its entirety, and unable to deliver pan-European multimodal, multi-operator, door-to-door travel:

##### *The Retail end of the supply chain:*

- In the indirect sales channel, examples of sites such as Rome2Rio and Waymate offer multimodal journey planners, but pricing of travel solutions tends to be inaccurate since there is incomplete structured interfacing with the Transport Undertakings providing the components of those solutions.
- At the same time, Rome2Rio redirects customers to the direct sales channels of the implicated Transport Undertakings for subsequent booking, payment and ticketing purposes, whilst Waymate, whilst offering booking and ticketing, would appear to suffer from a lack of comprehensive content, doubtless due to the cost of tackling the high level of interoperability required.
- In the direct sales channels, one-stop shopping applications tend to coalesce around the innovative activities of isolated transport undertakings with locally relevant partners: there is no

general standard or pattern, meaning that most examples have unique, proprietary and, therefore, costly 'expansion potential' attributes.

#### *The Distribution link in the supply chain*

- The Air sector is split between full service carriers and low cost carriers. They display radically different characteristics in the way they are distributed. Whilst the full service carrier sector is characterized by centralisation of schedules and fare data, low cost carrier favours the direct distribution channel, does not push its data or outsource its processes, and does not interline with other carriers. Recently, low cost carriers have begun distribution by independent or 3<sup>rd</sup> party distributors, but in a fairly limited manner, and always on its own terms.
- The Rail sector in general displays similar characteristics to the low cost carriers: schedule and fares data has to be requested by 3<sup>rd</sup> party distributors/retailers (ticket vendors). However, arrangements made between Railway Undertakings belonging to UIC, do make each others' fares available to each other in a central repository (the MERITS database) and they may distribute each other in their own direct sales channels.
- Urban Transit also has a tendency to favour direct distribution. Tickets for trams, buses or the metro are generally only available within the Operator's direct retail outlets at stations, although some Public Transport Authorities have made arrangements for 'smart tickets' such as the Oyster card (issued by TFL-Transport for London), to be purchased directly from 3<sup>rd</sup> party retailers (such as local tobacconists or news-agents).

#### *EU law, EC funded projects and Industry Initiatives*

- Legally binding standard for railway data exchange in EU is the TAP TSI and its technical documents standardizing timetable, fare and reservation data exchange.
- Relevant EC funded initiatives and industry initiatives such as FSM are usefully focused on standardizing, and therefore creating interoperability within the Rail Sector and within the supply chain between operators and distributors/retailers for rail products and services. The results of these projects will prove useful for TD4.2's wider multimodal ambitions.
- Relevant EC funded initiatives such as AWT and IT2Rail demonstrate wider multimodal scope, with the former providing informative pointers towards sustainable solutions in IP4, as a whole, and the latter designed to initialize the set of inter-related frameworks on which IP4 will build.

#### **Current major technical limitations:**

##### *Centralisation of data and processes*

The centralisation of schedule and fares data generally makes for rapid search and standardisation of data formatting. This was the approach taken by the airlines when they created the global distribution systems in order to promote their global distribution objectives, and led to outstanding success in achieving reach of full service carrier products and services.

However, the State of the Art reveals that outside of the Air Sector (and even within the Low Cost Carrier segment of the Air Sector) indirect distribution channels must be capable of managing



distributed data and processing. Direct distribution channels in these other sectors are still able to rely upon access to central repositories of data, so that, as with classic GDS technology and Google travel search, successful search and plan technology for the Rail industry is characterized primarily by a centralized approach.

Unfortunately, such an approach is not consistent with dynamic data, pricing for example, which is increasingly pursued as transport undertaking merchandising goals strive to become more sophisticated e.g. New Distribution Capability in the Airline Sector, and Full Service Model in the Rail Sector.

**Fragmentation of interchange message format and protocols** – the specific challenge for accessing distributed travel data and processing, is that the formats and protocols are different and various. The prospect of being able to access all operators from all modes, in terms of the cost and the time it would take supply chain distribution links to accommodate all varieties, puts the vision of the 2011 EC white paper on transport quite out of reach. At the same time, the prospect of developing a super standard, agreed and adopted by all operators, for all modes of transport, present and future, appears a very long and difficult process, even if some tentative exists with Transmodel/NeTex. Clearly, a more inclusive approach to this problematic is required.

**Multiple site shopping** – due to the distributed (non-centralised) nature of travel data and processes, and the fragmentation of interchange messaging, the customer is obliged to access different sites in order to gather information on possible solutions for different parts of his/her intended door-to-door trip. Unfortunately, the associated effort and risk means that far less travel plans are converted into travel sales than might otherwise have been the case.

**Lack of Information on carbon footprint and PRM:** finally, there is often simply insufficient information for the customer to make an informed choice, especially in relation to carbon footprint and PRM facilities/services. The customer is not fully in control of the search process today and must more often accept search parameters are due to the technological inadequacies of the search engine(s) than of his or her own search criteria.

### Technical Ambition of TD4.2

The technical ambition of the Travel Shopping TD is to create a Travel Shopping framework:

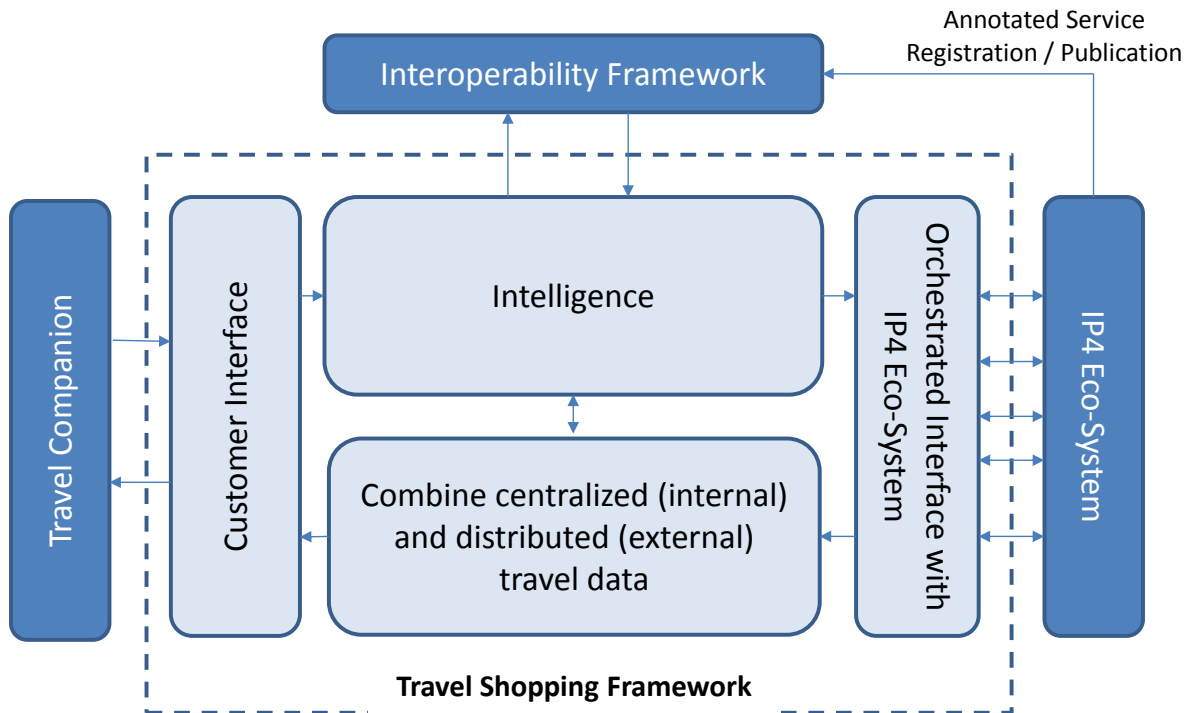

1. The 'Customer interface' establishes the connection between the Travel Shopping application and the Travel Companion of the customer, receiving and responding to mobility queries from the customer's Travel Companion.
2. The 'Intelligence' component interfaces with TD4.1 Interoperability Framework and queries it for generic Resolver Services: Location resolver to decode Customer Queries, Travel Expert Resolver to determine the virtual IP4 eco-system to be interrogated for each customer query. It retrieves the individual Travel Expert annotated services descriptors and a copy of the latest travel and transport ontology to feed the convertor technology used by the 'Orchestrated Interface' with the identified virtual IP4 Eco-System. It also draws upon both central and distributed data (from customer and/or periodic application queries) to create a meta-transport network reference enabling optimisation of its queries to the Travel Expert Resolver on the Interoperability Framework.
3. The 'orchestrated interface' with each query's virtual eco-system uses Convertor Technology to map the annotated service descriptors with the latest version of the travel and transport ontology in order to generate the appropriate query interchange messages expected by each Travel Expert in the IP4 Eco-System.
4. The 'Combination' component is able to handle all configurations of centralized/distributed travel data, in order to produce each Travel Solution appearing as alternatives on a list passed back via the Customer Interface to the Travel Companion of the Customer.

The Travel Shopping framework will enable TD4.2 to resolve or transcend the problems encountered by current state of the art shopping technology:

Topic	State of the Art	Problem	S2R-IP4	Resolution
Distribution	Centralised	1/ Dynamic Data 2/ Reluctance to push data	Adopt a technology which manages access to both centrally and distributed data sources and processing expertise.	Such a configuration will enable shopping technology to access comprehensive data sources, regardless of any actual configuration of centralized / distributed data as may change according to market dynamics and business strategy on distribution.
Interoperability	Fragmentation	Too many different formats and protocols: goal of White Paper out of reach due to cost and time.	Deployment of semantic web technology, and convertors.	The creation of a meta-layer of agreed semantics, an ontology of transport/travel, agreed across modes, provides for convertor technology to translate effectively between different message formats and/or protocols.
The Shopping experience	Multi-site	The shopping process demands considerable effort and time, with no confidence that all options have been considered	One stop shopping experience, with comprehensive choice of modes/operators including automated calculation of minimum connection times.	Takes the risk out of picking an 'infeasible' travel solution: transport becomes more 'reliable'. Customer feels they have been able to consider all options.
Customer control over search,	Inadequately established today: data attributes not available (especially for carbon footprint and PRM services).	Customer does not feel in control of their shopping.	Provision of a customizable set of travel preferences within the customer's travel companion	Customer is able to select or deselect specific modes / operators, and to drive the sorting of Travel Solutions according to his/her own set of priorities, whether it be – price, total travel time, comfort (ancillary services: wifi, lounge access, seat preference etc). as well as carbon footprint, and services and facilities for passengers with reduced mobility.

#### 4.5.2.3. Specific Demonstration activities and contribution to ITDs/SPDs

TD4.2 is one of the several inputs contributing to the real step change that IP4 will bring to the market and to the end users. The first main stream of IP4 is: "towards effective multi-modal travel services", and TD4.2 is clearly addressing this challenge for the Travel Shopping part; the second one is "customer experience applications" in which all transport services are seamlessly accessible to the



end users, and TD4.2 enables TD4.5 Travel Companion to deliver a one-stop shop Travel Shopping experience to the customer.

As already mentioned in the general description, the benefits that IP4 will bring to the market place requires an Integrated Technical Demonstrator ITD7 to demonstrate the complex interaction amongst the complete set of IP4 TDs. The approach is then to target a system level “complexity” and “maturity” (scope and TRL), called ‘release’ at system level, and to identify the functions needed at interactive TD level to achieve this objective.

Four main releases are planned at system level: IT2RAIL release in October 2017 (end of the project), Alpha release in December 2018, Beta release mid-2020, and a final release early 2022.

The functions and scope that TD4.2 will develop to implement the first 2 releases are described in the next section ‘Implementation of the Work Programme’.

The general demonstration process for TD4.2 “Travel Shopping” is to develop use cases supporting interoperability between Transport Undertakings and their downstream supply chain links in the construction of door-to-door travel solutions, as well as ensuring the distribution of intermodal travel products in the shopping process. At the most advanced maturity level, the demonstration will enable the production of feasible (minimum connection time validation), available, bookable, purchaseable and ticketable travel solutions whether these are aggregated from individual products and services, or already combined in intermodal products underpinned by commercial agreements between Transport Undertakings within the IP4 eco-system.

The demonstration scenario will take the form of different test campaigns for each of the planned system releases. It will cover the full extent of customer queries (from syntactic to semantic), the use of sophisticated convertor technology to tackle the fragmentation of interchange formats and protocols from the distributed travel experts in the IP4 eco-system which source primary travel data, journey planning expertise at geographical or operator/modal levels, and ancillary services providing carbon calculator processing or PRM data.

At the last release, the demonstration will target TRL6 with a prototype demonstration in a relevant environment, simulating operational conditions in terms of quality of service (network availability & quality, datacenter capabilities and connectivity), external conditions. Moreover, the prototype will rely on legacy hardware (in operation) to demonstrate the capacity to integrate legacy systems in the interoperability scheme. The demonstration will prove the Interoperability Framework and business application level Frameworks for Shopping, Ticketing and Trip Tracking.

#### **4.5.2.4. Impact of the Travel Shopping Demonstrator**

The main benefit of the ‘Travel Shopping Framework’ proposed within TD4.2 is to enable a one-stop shop travel shopping experience despite the fragmentation of distributed travel data available only in different transport markets today, and so establish a single multimodal market place:

- Provide participating travel retail outlets with the opportunity to position themselves within a travel shopping framework that can supply comprehensive coverage of the available transport products and services to meet any demand from their customers or Travel Companion applications representing them.



- Enable the cascading of customer preferences as parameters to drive the search for relevant travel solutions, as well as attaching the customer-specified attributes that enable comparison shopping and selection from the list of travel solutions so provided.
- Take the effort and risk out of today's shopping experience, through the automated calculation of minimum connection times, and applying combinability validation of solutions in terms of transport undertaking business rules on pricing, availability, and intermodal ticketing agreements underscoring intermodal products which can be purchased with a single payment and entitlements issued under a single integrated ticket.
- Provide participating transport undertakings with the certainty that their products and services always appear on the radar screen for customer travel queries for which they might be relevant.

#### **Strategic Impacts:**

- On the economics of the Travel Services Providers ecosystem:

Through its interface with TD4.1 Interoperability Framework, the enabled travel shopping framework convertor technology introduces massive reductions in system and operating costs for all links in the travel supply chains: distributors and transport undertakings are able to dialogue without having to invest in adaptations of interchange messaging between them. This should encourage a snow-ball effect of market uptake as retailers and transport undertakings realise that 'membership' will allow mutual access in order to unlock and exploit a much larger consumer demand than was previously possible.

- On the creation of a (Digital) Single European Railway Area (SERA):

The comprehensivity and combination power of the travel shopping framework will help ensure not only the emergence of a Single European Railway Area, but provide qualitative added value by enabling the SERA to interact and combine with the larger Single European Transport Area, liberating the inherent potential of Rail products and services to link services from other air, ground (including bus) and maritime transport sectors as well as integrating long distance and suburban rail with 1<sup>st</sup>, mid and last mile transport provided by participating public transport authorities.

- On the resolution of TAP- TSI open points:

TD4.2 "Travel Shopping" will contribute to the business coverage of the TAP TSI and the identification of the remaining open points to achieve complete business interoperability both within the rail sector and with other transport sectors and distributors dominant in indirect distribution channels, by providing convertor technology that can understand and translate TAP TSI messaging meaningfully without demanding compliance outside of the Rail Sector. This in itself will encourage accelerated take up and implementation of TAP TSI due to the added value of this potential external connectivity.



#### **4.5.2.5. Implementation of the work programme**

##### **Introduction**

The TD4.2 Travel Shopping implementation will be made as a key interactive component of the Integrated Technical Demonstrator (ITD7) implementation and will be developed according to the Agile methodology for software implementation.

Its implementation in successive reiterations following the logic of separate and successive ITD Releases, as initiated by the IT2Rail ITD (a first release) will allow a progressive increase in its TRL level alongside equivalent increases in the implementation of the other TDs with which it interacts.

The functionalities, capabilities, and scope of the Travel Shopping framework will be built successively and in synchronised fashion with those of its interacting TDs with each new ITD7 release.

Starting from the shopping for co-modal transport products and services, with simple pricing and availability characteristics, this progression will finally incorporate the shopping of intermodal products and services, which display far more complex algorithms in the determination of their pricing and availability.

Equally, the decoding/encoding of customer shopping queries will advance from simple origin-destination requests to handling more semantically expressed needs that may not expressly make reference to a specific destination (e.g. “where can I go for a 2-week golfing holiday in Europe for less than 1000 euros?” or “provide me a selection of complete travel solutions that will allow me to use my ticket for the next European Cup Final”).

Converto technology will move from one-to-one matching service dialogues to enabling dialogues between business applications which do not match on a one-to-one level: e.g. a distributor who generates separate service requests for booking, payment and ticketing, with a Transport Undertaking which expects a single request for the bundled execution of all three business processes.

In these ways, the power and sophistication of the Framework will be incrementally increased with each successive ITD release.



### Work Breakdown Scheme: Tasks

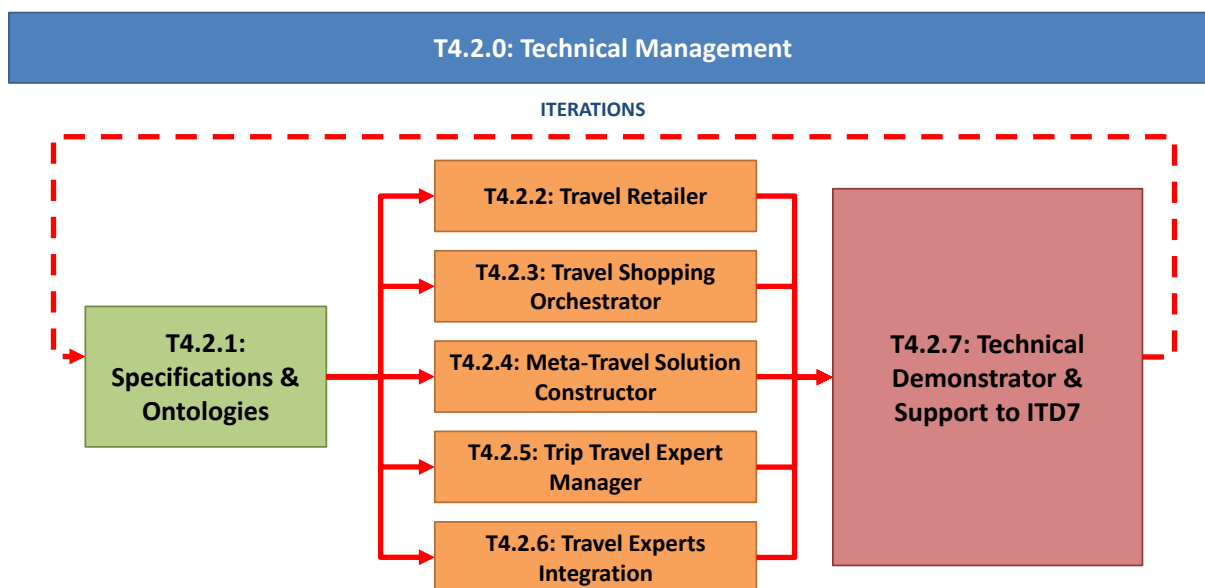

#### Task 4.2.1: Specifications & Ontologies

This collaborative task focuses on the definition of the Travel Shopping domain ontology and specification of the shopping functions of TD4.2 with architectures leveraging the enabling semantic web facilities of the Interoperability Framework (TD4.1).

It includes the exhaustive definition of a vocabulary of Terms or key-words common to the Travel Shopping domain and seeks to harmonise different definitions as may be sourced by different transport modes, whilst at the same time identifying important differences which may require the creation of new Terms in order to capture the semantics of modal differences. These ontologies will include European legislation such as CIV, passenger rights regulation and TAP TSI.

It proceeds to the formal description of key objects, roles and concepts, the relationships between them, and also attempts to identify TD4.2-specific Terms from Terms which may be shared with other TDs. The output is required for more formal harmonisation in TD4.1 whose task is to code an ontology of Travel Shopping and to store it in an ontology repository attached to the Interoperability Framework.

Following this effort, the contributors will produce specifications for individual software modules and open specifications for the Interfaces between different Travel Shopping components, and, between individual Travel shopping components and components belonging to other TDs.

The members bring expertise on urban smart ticketing transport applications and products, supplementary and combinable urban solutions for bus, carpooling, bike sharing and real-time parking space detection, as well as the orchestration of search, journey planning, and distribution for the air, long distance and suburban rail, and urban transit sectors.



#### **Task T4.2.2: Travel Retailer (customer interface) Software**

This task is performed around the interaction with TD4.5 “Travel Companion” which represents the customer, whereby, with the assistance of a Retailer Resolver on the Interoperability Framework (IF), the customer is able to select any Retailer services which are annotated and published on the IF service registry.

The task will focus on the necessity of the retailer software to capture the customer’s inputs and the engineering of input/output interfaces between Customer/Travel Companion (TD4.5) and the Travel Shopping Orchestrator component. Subsequently, the contributors will develop software components to capture the customer’s shopping list and preferences for the orchestration of their shopping experience. The Retailer software finally manages the communication of recommended Travel Solutions as returned by the Travel Shopping Orchestrator component.

#### **Task T4.2.3: Travel Shopping Orchestrator (TSO) software**

Contributors will engineer the input/output interfaces between Travel Shopping Orchestrator (TSO), Travel Retailer, TD4.1 'Interoperability Framework', and the Meta-Travel Solution Constructor components. The task consists of three main elements:

- Decode/encode Customer mobility query: the Location Resolver on the IF is called with the origin-destination inputs of the customer as solicited by the Retailer which returns a variety of relevant modal location codes (relevant airports, train stations, coach stations, and urban metro/bus/tram stops) and their geo-coordinates. This equips the Meta-Travel Solution Constructor (MTSC) with the full set of tools it requires to enable other components to manage calls to the different Travel Experts. For a retailer which allows for a more semantic, or natural language, expression of customer needs (e.g. I want to attend a specified ‘event’, I want to see a particular ‘point of interest’ or ‘building/monument’, or I want a specific ‘quality’ of trip (regardless of precise destination) the Travel Shopping Orchestrator may call other Resolvers (e.g. an Event Resolver) in order to establish destination references prior to interrogating the Location Resolver.
- Prepare the List of Travel Experts (the target ‘eco-system’) recommended for Interrogation: the Travel Expert Resolver on the IF is called based upon input of ‘smart routes’ (origin-destination and ‘mid-point(s)’ received from the MTSC. The ‘Mid-point(s)’ help identify the potential geography/corridor requirements for the selection of relevant Travel Experts (as annotated in their respective services).
- Return of the list of recommended Travel Solutions to the Retailer:

#### **Task T4.2.4: Meta-Travel Solution constructor (MTSC) software**

Contributors will engineer the input/output interfaces between the Travel Shopping Orchestrator (TSO) and the Trip-Level Travel Expert Manager (TL-TEM).

This task takes the decoded/encoded Customer mobility query from the Travel Shopping Orchestrator and uses it to define the requirements for the Travel Expert eco-system which the TSO will then identify by creating the list of Travel Experts to be interrogated.



Once received, the MTSC passes this list together with relevant customer preferences regarding the attributes to be collected from each travel expert query, to the Trip Level Travel Expert Manager (TL-TEM).

Finally, the MTSC will combine the results received back from the TL-TEM in order to produce the full list of customer preference compatible Travel Solutions, which include customer determined attributes at both total trip and individual segment level (carbon footprint, price, total travel time, PRM facilities and services, etc.).

This task includes the development of software components to identify the smartest origins, destinations, and mid-points, from a dynamically updated Reference Network Resource together with algorithms based upon historical pricing and passenger flow density, in order to optimize the subsequent search.

#### **Task T4.2.5: Trip Level Travel Expert Manager (TL-TEM) Software**

Contributors will engineer the input/output interfaces between the Meta Travel Solution Constructor (MTSC) and the individual Travel Experts belonging to the target eco-system relevant to a particular mobility query.

This task will produce the Trip-Level Travel Expert Manager (TL-TEM) which is the software required to manage the multiple and parallel calls to the individual Travel Experts making up the target eco-system. It receives the list of Travel Experts to be interrogated, their annotated service descriptors, a copy of the latest ontology (or default on cached version), and customer preferences which may act as parameters to derive further transport service attributes (e.g. CO<sub>2</sub>, PRM etc.) from its Travel Expert dialogues.

The task makes use of a convertor capability, using the ontology and each Travel Expert's annotated service descriptors to generate the correct message(s) expected by each Travel Expert.

Contributors will ensure that in the case of Intermodal travel products/services, the capability to handle both availability and pricing specifics pertinent to these Intermodal/Integrated type of transport products, is integrated into the final results returned to the MTSC.

#### **Task T4.2.6: Travel Experts Integration**

This task comprises the integration of 'IP4' compliant Travel Experts, and so requires a contribution from each partner wishing to contribute as a Travel Expert within T4.2. Ultimately this task provides the basis for establishing the addressable transport products and services for the IP4 compliant eco-system from which the construction of any given Travel Solution can be sourced. Each Travel Expert uses the IP4 ontology to annotate the service descriptors of its web-services / APIs, and then subsequently publish them in the Interoperability Framework Service Registry.

A Travel Expert may be one or more of three types:

**Type 1** – A Transport Undertaking or Transport Product Owner (such as a Rail Operator, Airline or Public Transport Authority) with journey planning expertise, ownership and responsibility for the pertinent schedule, tariff/fare, and availability data, as well as real-time operational data.

**Type 2** – A Travel Expert Manager, with journey planning expertise, which aggregates multiple data (schedule, tariff/fare, availability, real-time information) from other Travel Experts (of any of the three Types).

**Type 3** – A Specialist Travel Expert, with no journey planning expertise, but which may supply certain very specific information/processing expertise, in relation to Transport Products (e.g. an urban transport Product Catalogue, a Carbon Calculator, an inventory of PRM service information across a transport network, etc.)

Among the contributors to TD4.2 are Travel Expert Managers (Type 2 Travel Expert) and a Type 3 Travel Expert. The combination provides for the Air, Rail and Urban Transit sectors with added value characteristics, which allow for the integration of 1<sup>st</sup> and last mile with longer distance transport modes, and additionally, the integration of urban transport products which are not necessarily unified within a smart ticketing system, but which do contribute to ITS goals for the elimination or diversion of private car usage from city centres in order to reduce congestion and pollution. In particular, and based upon relevant Real Time data, this includes the provision of parking space detection capabilities, private car/bike pooling/sharing facilities and the availability of rental mobility modes.

***Open Calls (to handle the absence of type 1 and other type 3 travel experts).***

*We lack Travel Experts of Type 1 for fundamental schedule, fare/tariff, and availability information, with related journey-planning, and of Type 3 for information concerning carbon footprint and PRM facilities for all relevant modes. Open calls need to be published to encourage participation of relevant travel experts synchronised with the member calls for the enrichment of scope and functionalities associated to the overall Travel Shopping framework and its various components. Such open calls need to combine the corresponding needs of TD4.3 Booking and Ticketing for travel experts with the relevant booking, payment and ticketing services.*

**Task T4.2.7: Technical Demonstrator & Support to TD7**

This task is the link between the TD4.2 technical demonstrator and the overall IP4 demonstrator. It consists in the integration of all implemented software components and functions for Travel Shopping across all modes, the activities to ensure convergence of internal and external interfaces, performances and functionalities and the production and demonstration of a complete Travel Shopping Technical Demonstrator.

**Contribution to the system releases ITD4.7:**

The first release is the IT2RAIL release,

As the final deliverable of the IT2RAIL project, scheduled in October 2017, TD4.2 will put in place the basic Travel Shopping framework and its interface with TD4.1 Interoperability Framework.

Travel Shopping application will be limited to searching for co-modal Travel Solutions i.e. will combine separate products and services offered by the available Transport Undertakings to build each solution.



The available Transport Undertakings are limited to those in the IT2Rail consortium who will offer only products and services applicable to specific corridors (TBD).

The use cases presented for IT2RAIL is a small subset of all the possible use cases that will be addressed by the Shift2Rail IP4. The IT2Rail release implementations of IT2RAIL WP2 (equivalent of TD4.2 in S2R) will be as follows:

- Implementation of the basic components of the Travel Shopping Framework and interfaces with other TDs
- Customer Interface (Retailer software) and Intelligence components (Travel Shopping Orchestrator) of the Travel Shopping Framework will deal with customer queries referencing specific origin and destinations only (via current sector-relevant location codes, or by origin and destination addresses).
- Products and Services for the travel solutions will be comodally offered services, only. This means a very basic 'add-on' pricing approach, and a non-complex availability response.
- Convertor Technology will map dialogues at the atomic level of single business transactions only: a booking request for a booking result (TBC).
- Shopping will be confined to possibly only 2 corridors and the IT2Rail consortium member eco-system Travel Experts only.

#### **The second release is the alpha release**

This release will enrich the sophistication of all business application frameworks as well as the Interoperability framework, but still sticking to shopping for co-modal products and services. Enriched sophistication will be based upon:

- Customer Interface (Retailer software) and Intelligence components (Travel Shopping Orchestrator) of the Travel Shopping Framework will deal with event-type queries (TBC) which do not specify destination locations, this being left to an Event Resolver on the Interoperability Framework which can return relevant destination location references, together with date/time and duration parameters to guide subsequent shopping search.
- Convertor technology will be upgraded (TBC) to tackle more complex mapping of 'atomic' requests with 'fat' services (bundled business processes) when querying the IP4 eco-system.
- Combination components will (TBC) attempt to enrich the reference meta transport network and associated algorithms from which to derive 'smart routes'.
- Overall a wider selection of transport corridors and travel experts (via relevant open call(s)).

#### 4.5.2.6. Planning and budget

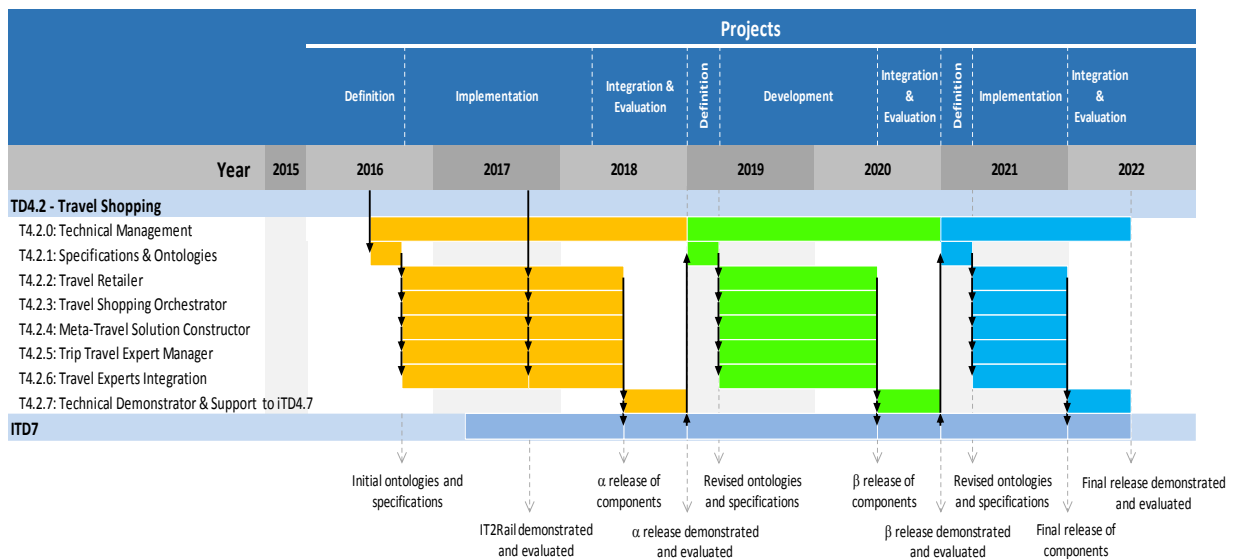

The estimated total budget for TD4.2 is around 11.6M€.

### 4.5.3. TD4.3 Booking & Ticketing

#### 4.5.3.1. Concept and objectives of the Booking & Ticketing Demonstrator

The concept of the “Booking & Ticketing” TD is to allow multi-modality across Europe and across the modes. Today, even within a given mode (Air, Rail, Urban, etc.), the rights to travel have at best a limited interoperability between the various travel service operators, and this interoperability is almost non-existent between the modes themselves. From the “Booking & Ticketing” perspective, fostering multi-modality therefore requires a grand unification of the way the rights to travel are thought about. This TD will look at how to provide such framework for all transport operators and other service providers across Europe. This includes cataloguing the “entitlements”, describing and unifying their lifecycles (as much as possible, specificities for various transport modes will be managed as such), defining principles to interact with the Ticketing framework and identifying the necessary use cases to demonstrate the functionality included as part of this framework.

This analysis is directly answering to the Master Plan objectives:

- Define “harmonised terms and definitions of processes for the different services (... ticketing, validation..., settlement).
- Enhance “media independent ticketing or travel entitlement data content to achieve complete interoperability between different modes”.

The functional definition is starting from a careful analysis of the “booking and ticketing” steps, with the view to harmonize generic principles (see below the definition of the chain: Entitlement -> Token -> Embodiment), and taking into account the interaction with the travel companion wallet storing all information related to a journey.

Based on this analysis, it is possible to identify the following objectives which contribute to one-stop-shop solutions/applications for multi-modal ticketing:

Objective	Result	Practical (concrete) Deliverable
Harmonisation of the Management of the rights to travel (entitlements)	Harmonisation for travellers and stakeholders, clarification about rights and obligations	Specification of entitlements, characteristics and attributes, and lifecycle (including specificities for some modes when necessary) Target: Cover 100% “standard” entitlements (air, train, long-distance bus, daily/weekly/monthly/yearly passes, origin-destination/zonal, etc.),
Storage of Entitlements in Cloud Wallets	Giving ubiquitous access to entitlements for all travellers and stakeholders	Principles for ubiquitous access including security and privacy requirements Target: ability to connect different cloud travel wallets (TD4.5) implementations certified against the standard
Entitlement Tokens Management	Harmonisation of management of Tokens associated to Entitlements whatever the physical media implemented.	Implementation of the lifecycle, characteristics and attributes. Target: 100% cover of standards entitlements tokens
Service Managers Management	Harmonisation of management of service providers and integration with them.	Principles, mechanisms of communication and implementation of the service providers’ management and integration: facilities for Registrar, facilities for Security Manager, facilities for Entitlement Management. Target: Acceptance of principles considered valid by major service providers from different European countries
Reduction of gap between entitlement and embodiment.	Ubiquitous access to travel rights without necessity of an embodiment, practical aspect (no need to fetch and manage embodiments) and environment aspect (no wasted paper/tickets)	Demonstrator of travel using only entitlements and electronic entitlement tokens, no physical embodiment Target: Acceptance of demonstrator (conditions of acceptance to be determined)
Harmonisation of Payment Methods for Entitlements	Harmonisation for travellers and retail participants, better understanding of the scheme	Specification of the payment for the Entitlement according to its Lifecycle (including specificities for transport modes when necessary), Demonstrator Target: Acceptance of demonstrator (conditions of acceptance to be determined)
Harmonisation of Settlement for Entitlements	Harmonisation for retail participants and provider participants, better understanding of the scheme	Specification of the settlement for the Entitlement according to its Lifecycle, Demonstrator Target: Acceptance of principles considered valid by major service providers from different European countries
Security	Harmonisation of the necessary security measures to deal with different entitlements and entitlement tokens possible implementations.	Principles and implementation of security mechanisms. Target: Acceptance of principles considered as valid by major service providers from different European countries



#### **4.5.3.2. Technical ambition of the Booking & Ticketing Demonstrator**

The TD4.3 “Booking and Ticketing” can benefit from several EU initiatives and regulations. They have the ambition to unify the rail sector and to provide interoperability, the most relevant being:

- TAP-TSI regulating and developing a set of technical specification for the Rail Industry designed to establish base-line standards for cross-border rail services and reference data.
- FSM developing door-to-door Rail products & services distribution across all distribution channels (domestic & cross-border).
- STA developing relevant trust schemes and specifications defining urban needs for cross-border Ticketing technologies.

None of these initiatives have the ambition to tackle completely the variability needed in an open multi-modal ticketing system, but they will be used as key inputs in their relevant segments.

The TD on “booking and ticketing” will completely leverage on the 2 DG-Move projects AWT and IT2RAIL, both developed with the same group of partners, and defined as the first steps of our stepwise approach for Shift2Rail IP4.

- AWT which is developing a study and POCs showing the integration of long distance and local transport capabilities, achieved without integration of ‘standards’
- IT2RAIL, project from the first H2020 call for transport, which is really the first step of our IP4 strategy for “booking and ticketing”, but addressing only the co-modal approach (multiple tickets) with simple use-cases and a limited number of modes and without post-treatment like clearing and settlement.

#### **Current major technical limitations:**

Today, although there is some movement towards “electronic ticketing” (mostly for air travel, less for train, and even less for urban), most entitlements are still not manageable in electronic form. And even when they are, the way to manage them is usually extremely inconsistent from one provider to the next.

Also, even when the entitlements are manageable in electronic form, there are many limitations to this, in particular because of proprietary sites and access restrictions (e.g. specific travel cards with proprietary applications and security keys).

In most cases, even electronic entitlements necessitate a transition to a (semi-)physical embodiment, for example when an electronic ticket needs to be printed or accessed through a proprietary application on a mobile phone.

In terms of “shopping”, today, multi-modality is mostly covered by multi-shopping, which in turns provides multi-tickets, with absolutely no link to each other, even in the niches where intermodal ticketing exists (as can be the case with Air-Rail, Urban Transit, and some Rail-Ground Transport cases run by Rail Providers) but which do not span all Transport Modes.



In general, there is no harmonisation of the payment and settlement segments either: as tickets are sold and managed separately, payments are very often quite different (and hard to track for the traveller), and the settlement follows only specific cases for the few cases of intermodal ticketing agreements already in place.

### **Technical ambition of the TD4.3:**

The extended interoperability between modes, operators and systems offered by the '*Ticketing Framework*' setup by the TD4.3 will provide travellers with the possibility to book and pay in a 'one-click' action a complete multimodal door-to-door travel journeys and to validate the acquired travel entitlements across heterogeneous transport systems, making optimum use of cloud computing connecting technologies.

The initial concept of the ticketing framework is to provide system-to-system interoperable rules and enabling technologies allowing every actor in the eco-system to communicate and interoperate at the business level without the need for a global single European-wide integration platform or for a central authority structuring and regulating the market. Components specialised in a specific Booking & Ticketing functions for a given mode will be able to join the ticketing framework and to interface at their level with similar component of other modes, thus enabling deep component interoperability and modularity.

By decoupling business and technical interoperability in different components within the '*Ticketing Framework*', the ambiguous notion of travel ticket will evolve toward the new concept of Entitlement / Token / Embodiment (ETE) triple and allow greater interoperability of travel rights across the whole transportation ecosystem:

- *The IP4 Entitlement will capture the business value* within the ticketing framework as it represents the right acquired (e.g. through travel-shopping) or possessed by a potential traveller (e.g. by the virtue of being in possession of a credit card). This is the instantiation of a contractual agreement between the traveller and service providers and can be understood ubiquitously by all actors participating in an intermodal scheme.
- *The IP4 Token is the technical pendant of the Entitlement* as it permits a service provider to perform the due service. Because it is linked to the entitlement, the token enables interaction with the entitlement throughout the infrastructure of operators and service providers. Exclusively electronic and dematerialised, the token is an instantiation of the entitlement within a specific organisation, mapping dynamically the particulars of the ticketing and validation environment for this organisation through the discovery capability of the Interoperability Framework (TD4.1).
- *The embodiment is the last element of the Triple.* It is essential to ensure that legacy ticketing systems can interact with the IP4 ticketing framework when electronic forms of ticket are not recognised. It is the fare media, linked to an Entitlement-Token, enabling interaction with the legacy devices and infrastructures of the operators and service providers (offering downwards compatibility).
- *Benefiting from the complete dematerialisation of the entitlement,* the '*Ticketing Framework*' will provide interactions with electronic cloud wallets and unique identifiers to allow secured

ubiquitous access to traveller's entitlements and itinerary. These mechanisms will provide the traveller with a global identity and associated rights accessible by the European operators and services providers.

- *Additionally, addressing the ticketing interoperability through the business angle, TD4.3 will consider the criticality of the clearing and settlement functions and consider systematically the capacity to apportion and settle payment of every ticketing operation within the eco-system and any contractual schemes.*

**Figure: example of the complex ticketing ecosystem for public transport**

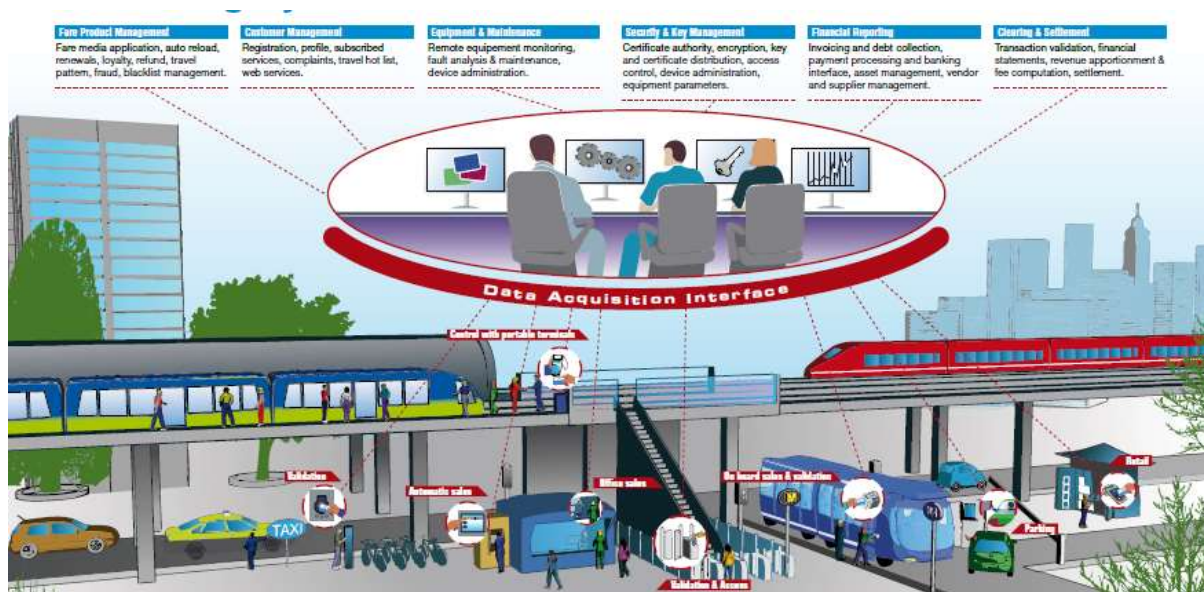

In the figure above, we can see that the ticketing eco-system is already very complex if we consider the standard public transport modes only. Trying to extend it to take into account all modes is requiring a deeper level of abstraction:

The Entitlement / Token / Embodiment chain will allow a downwards” compatibility to existing systems, allowing willing operators to join the scheme without forcing them to modify all their existing systems.

In turn, this will provide the solution to all the remaining problems of the current baseline:

- Non-existent or inconsistent management of electronic ticketing: addressed by the top-down ubiquitous standard
- Inconsistent proprietary local management: addressed by the Entitlement -> Token -> Embodiment principle
- Transition to (semi-)physical embodiments: addressed by the Entitlement -> Token -> Embodiment system, although it must be noted that this will provide a path forward but not immediately remove the embodiments across Europe as local system will need to be updated, although at their own pace and in their own time



- No link between various kinds of entitlements, in particular across transport modes: addressed by the top-down standard, in turn supporting a one-stop shop for intermodal multi-ticketing.
- No harmonisation of payment and settlement: addressed by the top-down ubiquitous standard and in particular the services extensions

In addition, although a specific TD (TD4.2 Travel Shopping) is dedicated to the shopping, the actual sale will be handled by the TD 3, because TD 2's objective is only providing priced offers. One of the major processes of Ticketing is converting an accepted offer into entitlements, involving the necessary payments (and obviously further settlements). One of the major aims of IP4 being to implement multi-modality (as well as co-modality), it therefore implies that TD4.3 will be in charge of actually implementing the multi-modal and co-modal sales, and all associated processes like post sales, payment and settlement. This is certainly an innovative perspective in itself considering the wide variety of entitlements that need to be processed and systems to interact with, in all transport modes, and all across Europe, especially considering, in addition to the pre-sales (prevalent in Air and Train), the pay-as-you-go and post-sales models that are increasingly becoming present in Urban and which will certainly interest Air and Train once the models are validated and integrated.

Moreover, this TD will allow the smart integration of the fare media offer which is today very fragmented. A number of new technological advances are being made in terms of Entitlements, Tokens and Embodiments. Some of them are fairly advanced (e.g. Open Payment), and have been deployed in operations, others are more in the experimental stage (e.g. NFC), and others have barely started to be envisioned (e.g. Be In Be Out, Bluetooth Low Energy, etc.). One of the purposes of the Ticketing TD is to investigate all these advances, and to integrate them in the Ticketing Framework. Note that, because these subjects are sometimes very innovative and can be fairly clearly detoured, they would make good subjects for Open Calls.

Finally, in relation with TD4.5 Travel Companion, the TD4.3 will introduce ticketing device and fare media interaction into a connected environment. Allowing dynamic interface between the two items, it will enable seamless usage of the transportation system for the traveller while guaranteeing the security and limiting the risk for the service provider.

#### ***4.5.3.3. Specific Demonstration activities and contribution to ITDs/SPDs***

TD4.3 is one of the several inputs contributing to the real step change that IP4 will bring to the market and to the end users. The first main stream of IP4 is: "towards effective multi-modal travel services", and TD4.3 is clearly addressing this challenge for the Booking & ticketing part; the second one is "customer experience applications" in which all transport services are seamlessly accessible to the end users.

The general process applying to TD4.3 "Booking & Ticketing" is to develop use cases supporting interoperability between ticketing systems. At the most advanced maturity level, the demonstration will involve multiple service providers cooperating to issue a single intermodal entitlement. Each service provider will include its specificities by delivering an entitlement token that will be used to consume its service (access to transportation network). The demonstration will include hardware devices in a simulated operational environment.



The demonstration scenario will take the form of test campaigns for the different system releases. It will cover the full extent of the entitlement lifecycle, the use of multiple entitlement tokens demonstrating multiple validation schemes. Operational scenarios will envision complex cross-providers processes such as refund and claim on intermodal journey as well as fallback scenarios (example given: provider did not meet its commitment when booking or issuing entitlement).

At the last release, the demonstration will target TRL6 with a prototype demonstration in a relevant environment, simulating operational conditions in terms of quality of service (network availability & quality, datacenter capabilities and connectivity) and external conditions. Moreover, the prototype will rely on legacy hardware (in operation) to demonstrate the capacity to integrate legacy systems in the interoperability scheme. The demonstration will prove the interoperability scheme between service providers with full extent of the operational scope. It includes different kind of degraded modes, technical to address resilience but also operational such as claim or refund use cases.

As clarified already in the general IP4 description, the step change will not come from the individual TDs but with the Integrated Technical Demonstrator ITD7 which is combining all IP4 TDs inputs. The interfaces between the TDs are massive, and developing an independent platform to demonstrate separately the TD4.3 is duplicating completely the work. The approach is then to target a system level “complexity” and “maturity” (scope and TRL), called release at system level, and to identify the functions (at TD level) and the necessary hidden technical toolkit to achieve this objective and not the other way around.

Four main releases are expected at system level: IT2RAIL release in October 2017 (end of the project), Alpha release in December 2018, Beta release mid-2020, and a final release early 2022.

The functions that TD4.3 will develop to implement the first 2 releases are described in the section on implementation.

#### **4.5.3.4. Impact of the Booking & Ticketing Demonstrator**

The main benefit of the ‘*Ticketing Framework*’ proposed within TD4.3 is to abolish the complexity of a Ticketing scheme adapted to a multi-modal heterogeneous environment:

- Provide ubiquitous access with consistent security and privacy. This will allow a rally of all ticketing operations across Europe around this core for inter-modal journeys, cascading down to local travel organisations. In a sense, it is a completely reverse way of doing things: from the top down, rather than trying “bottom-up” to reconcile local initiatives across an extremely wide field of application.
- Accelerate the movement towards “electronic ticketing” (developed mostly for air travel, less for train, and even less for urban). Today, most entitlements are still not manageable in electronic form. And even when they are, the way to manage them is usually extremely inconsistent from one provider to the next. Also, even when the entitlements are manageable in electronic form, there are many limitations, in particular because of proprietary sites and access restrictions (e.g. specific travel cards with proprietary applications and security keys).
- Foster the emergence of inter-modal booking and ticketing: multi-modality is mostly covered today by multi-tickets, without link to each other. In comparison, the aim of TD4.3 is to support a



one-stop shop multi-ticketing for all travel modes and inter-modal, overcoming the current interoperability challenges, and to propose the harmonisation of the payment and settlement segments.

- investigate and integrate consistently within the ticketing framework the evolving state-of-the-art in terms of Entitlements, Tokens and Embodiments technological solutions. Ranging from Open Payment technologies, NFC contactless smart phones to innovative solutions such as Active Tags, Bluetooth Low Energy; these innovative technologies will be considered in the scope of the 'Ticketing Framework'.

#### **Strategic Impacts:**

- On the economics of the Travel Services Providers ecosystem:

Benefiting through the Interoperability Framework (TD4.1), from an access to an open-ended world of booking and ticketing resources and leveraging the Travel Companion (TD4.5) cloud computing capabilities, the TD4.3 booking and Ticketing will enable a sustainable ticketing framework which will, in turn, allow market forces to accelerate the creation of inter-modal products. By decoupling the business constraints from the technical ticketing interoperability issues, and offering global multimodal mechanisms for the later, the TD4.3 will indeed reduce investment costs for truly inter-modal transport offers.

- On the creation of a (Digital) Single European Railway Area:

The flexibility in the transport offers created by the IP4 TD4.3 "Booking & Ticketing" technical demonstrator will allow better transport policy efficiency for Public Transport Authorities (PTA). As the constitution and composition of existing products will integrate inter-modal products, the coherence of the public transport policy will be facilitated by the ability of the PTAs to control and define precisely the way its urban products and prices will be integrated into inter-modal offers.

In the same way, the increasing availability of inter-modal travel offers and especially the connectivity of urban and main lines railways will lead to the increase of rail attractiveness and alongside; increase the usage of rail transportation as the option become more available to the traveller.

- On the resolution of TAP- TSI open points:

TD4.3 "Booking & Ticketing" will contribute to the business coverage of the TAP TSI and the identification of the remaining open points to achieve complete business interoperability in the rail segment. By demonstrating the interoperability that is required to interconnect TAP TSI systems with other modes of transportation such as airlines, TD4.3 will leverage results of the TAP TSI initiative and accelerate its global acceptance by the rail market.

#### ***4.5.3.5. Implementation of the work programme***

The approach and methodology chosen for IP4 are centred on the introduction of a '**Technical Enabler**' composed of several TDs, each one based on a standard software development methodology. The interoperability framework guarantees technical interoperability between all

multimodal services through the creation of a “Web of Transportation” where an open-ended world of annotated data, services, events and resources can be published, searched and accessed by business applications.

For what TD4.3 is concerned, using the services of the Interoperability Framework, the Booking & Ticketing component locates and interacts with multiple booking engines and/or payment processors distributed across the network to generate bookings and entitlements for one or more of the itineraries selected by the citizen on the Travel Shopper. Ticketing also coordinates payments as requested, and stores created objects (e.g. entitlement references/tokens) in the citizen’s Travel Companion.

Multimodality and seamlessness are especially visible also through the Traveller being able to navigate throughout the heterogeneous urban transport environment (card centric systems, back office centric, electronic entitlement tokens or their physical embodiments, near field communication technologies etc.). The capability to access older generation transport networks whilst offering an open and adaptive capability towards the latest progress of the transport industry (near field communication technologies, EMV payment etc.) is at the heart of this multimodal service.

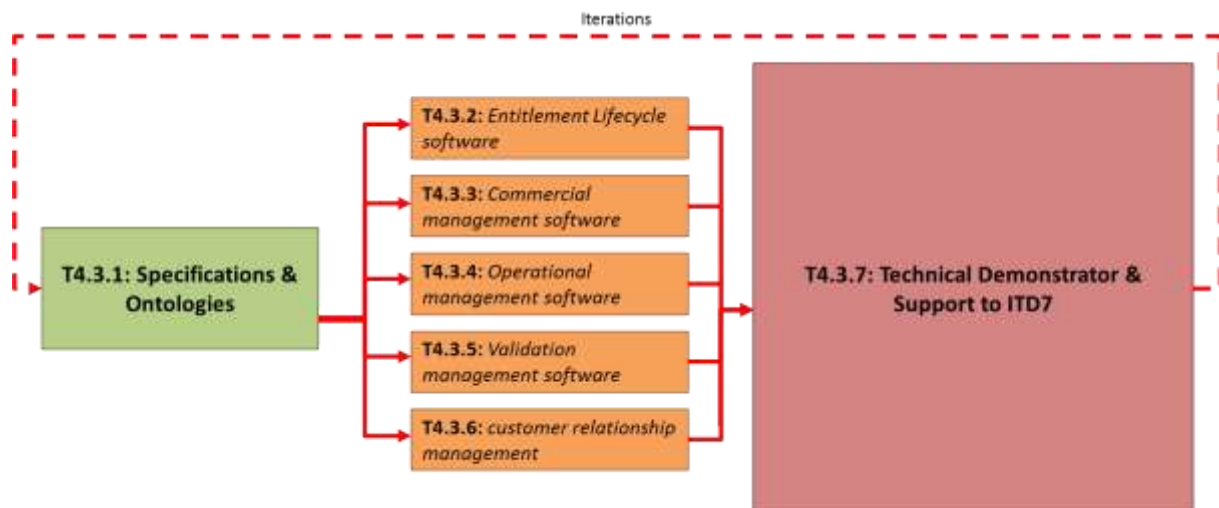

### **T4.3.1: Specifications & Ontologies**

Within this collaborative task, contributors from the transportation ecosystem will define interoperability mechanisms of the TD4.3 “Booking & Ticketing” functions with Interoperability Framework (TD4.1), effecting access to the ‘Web of Transportation’. This will be performed by producing open specifications for a Booking & Ticketing technical enabler effecting multiple modal implementations, exhaustive definition of a vocabulary of semantic terms (ontology) common between transport modes, and formal description of key objects, roles and concepts shared by the Booking & Ticketing functions. Based on the previously stated activities, the contributors will select, engineer and document a possible solution’s architecture and technologies to match the requirements.





#### **T4.3.2: Entitlement Lifecycle software**

This collaborative task between contributors encompassing a variety of transport modes (such as Urban, Rail, Air, etc.) will establish a new concept of travel rights with the emergence of a triplet concept Entitlement/Token/Embodiment (ETE) to allow business multimodal interoperability. Contributions will unify travel rights concepts across modes through the cataloguing of current and future type of entitlements and formal description of their unification lifecycles. Contributors will develop software components for Entitlement Lifecycle functions to manage acquisition, usage and disposal of travel rights with respect to the IP4 TD4.3 concepts.

#### **T4.3.3: Commercial management software**

The contributing parties will define the needed mechanisms to support co-modal and inter-modal operations in a ticketing system, working collaboratively to integrate the concepts through the main transportation modes. Such activity will provide reference implementation of orchestration of multiple dialogues across pricing, and payment, clearing and settlement engines, management of customer accounts repository (name, address, phone no., payment means, claims etc.). It also includes the development of software components for pricing, payment, clearing, settlement functions within IP4 context and supporting multiple systems and operators. The components will rely on ontology repositories and packaged resolvers as deployed by Interoperability Framework (TD4.1).

#### **T4.3.4: Operational management software**

With this task, a number of software components will be specified and developed to support the operations of ticketing back offices in multi-modal and multi-operators environment. It includes the production of software components to manage lifecycle of operational parameters (including fares, topologies, product definition, time bases, dictionaries etc.), provide management, supervision, maintenance, organisation and configuration tools for booking and ticketing resources, manage security aspects of deployed systems (equipment authorisation etc.).

*There is room in this task for open call to develop additional components.*

#### **T4.3.5: Validation management software**

This task focuses on the validation and inspection of the entitlement of the traveller throughout the multimodal transportation networks. It is strongly linked with the TD4.5 “Travel Companion” tapping task which interface the TD4.3 validation with the field devices. From a functional point of view this task produces component managing access to transportation network through presentation of travel rights and assessment of validity of media. It includes the following software functionalities: dynamic presentation of travel rights upon transportation network context (access and control), model operating and financial risks associated with unauthorised access to transportation network, update of entitlement according to defined lifecycle in accordance with usage of traveller, interface with user Travel Companion (tapping functions). Under this task the contributors will develop software components for validation and inspection functions which can operate in a variety of modal environment, following different approaches such as card-centric and account-based.



#### **T4.3.6: Customer relationship management**

This task will define collaboratively the mechanisms for co-modal and inter-modal booking operations across the overall transport ecosystem offers, but related to the customer relationship management. The activities include development of components to provide assessment of availability and conflict management with multimodal logic; producing software components for booking functions operating within multimodal/multi operator environment; loyalty programmes management etc

#### **T4.3.7: Technical Demonstrator & Support to ITD7**

The contributors will integrate in a common demonstrator all implemented software components and functions for “Booking & Ticketing” across the multiple modes involved in a relevant environment. By ensuring convergence of internal and external interfaces and verifying performances and functionalities, this work will build a reference implementation of the “booking and ticketing” which will be guarantor of the feasibility and scalability of the enabling technologies proposed.

This integration will be monitored by ITD7, in charge of the system level release, integrating all inputs from the different TDs.

#### **Contribution to the system releases ITD7:**

The first release is the IT2RAIL release.

As the final deliverable of the IT2RAIL project, scheduled in October 2017, TD4.3 will put in place the basic Booking & Ticketing framework and its interface with TD4.1 Interoperability Framework.

The available Transport Undertakings are limited to those in the IT2Rail consortium who will offer only products and services applicable to specific corridors. The objectives will be applied to four main modes of transportation: urban, air, rail and long distance buses.

The use cases presented for IT2RAIL is a small subset of all the possible use cases that will be addressed by the Shift2Rail IP4. The IT2Rail release implementations of IT2RAIL WP3 (equivalent of TD4.3 in S2R) will be as follows:

- Implementation of the basic components of the Booking & Ticketing Framework and interfaces with other TDs
- Entitlement Lifecycle functions enabling a complete template for multimodal dematerialised travel rights extending the possibilities for a variety of travel media across all modes;
- Commercial functions specifying and instantiating in a co-modal limited complexity the management of travel rights purchased with credit cards across transport modes for multi-segments journey.
- Operational Management functions allowing the emergence of co-modal (but taking into account the constraints of a multimodal global approach) interoperable back office functions allowing



greater supervision of transport ticketing infrastructure, management of travel products, fares, topologies and financial rules;

- Validation functions leveraging on the introduction of high capability Traveller connected devices interfaced with electronic wallets in a virtualised environment to provide Travellers with easy access to validation infrastructure across their journeys.

### The second release is the alpha release

Booking & Ticketing TD4.3 will pursue activities related to co-modal Travel Solutions, and specifically on the management of fall-back alternatives when a disruption occurs. Additional guarantees for the passenger should be provided, linked in particular to the risks coming from the simultaneous purchase of multi-tickets, multi-vendors' products.

For this purpose, TD4.3 will develop the relevant settlement infrastructure required to support the co-modal type of product/service retailing and after-sales business functions. To support this capability, the ticketing systems will rely on harmonized orchestration of dematerialized entitlements enriched by post-sales processes. Furthermore, a novel approach to business, operational and tickets inspection/validation processes and software will be provided.

#### 4.5.3.6. Planning and budget

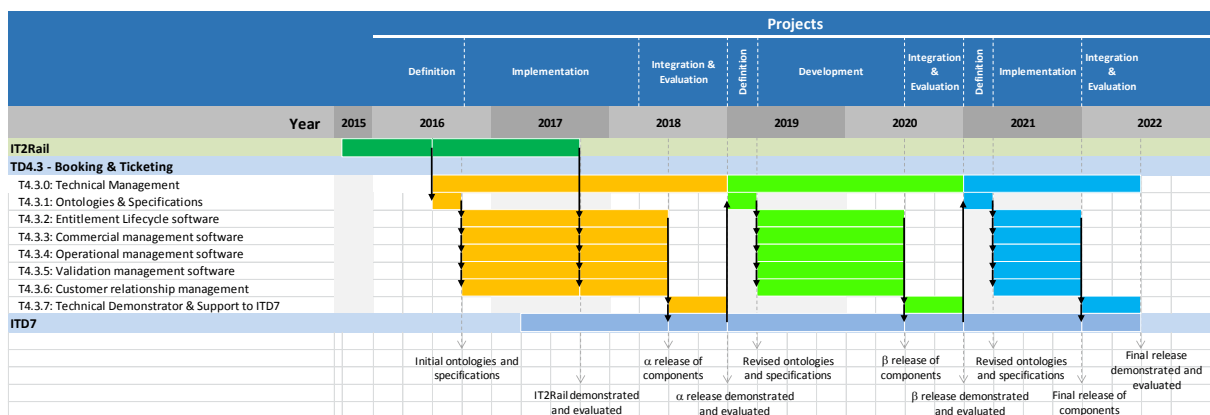

The estimated total budget for TD4.3 is around 22.7M€.

### 4.5.4. TD4.4 Trip Tracker

#### 4.5.4.1. Concept and objectives of the Trip Tracker Demonstrator

We are living in a society which is characterized as a mobility world. For humans it is absolute normal to use their possibilities in private transport to travel from A to B or to use ones car to go to work in the morning and back home on the evening. For all those humans it is as well normal to be informed about the actual situations on the streets. You switch on your radio and you will be informed about traffic jam, closed roads, closed exits and so on. In the same way a driver will be informed when he starts his navigation device in his car. The system proposes different routes taking into account any kind of obstacles and barriers. During the trip push notifications inform the driver about upcoming



jams providing him with alternative routes. All this is normal for us and we all expect that the systems are working like that.

In respect to public transport we are only at the beginning of an assistance of travellers like we already have in private transport. Departure timetables presenting us real time information on stations and airports are working but the missing link is the combination of both. The attractiveness of European Railway lies fundamentally in the capabilities to contribute to the social infrastructure by providing smart and green travel services. With an ever increasing complexity of transport solutions, spanning across regions, operators infrastructures and modes, irregularities and anomalies in planned journeys need to be identified to provide a traveller with a seamless door to door and barrier free travel experience. Door to door in this respect does not mean to use public transport instead of private transport but any kind of useful combination of it whether using car, bus, bicycle, flight or train. This will be one the most important steps forward to convince humans to use public transport instead of private transport.

TD4.4 “Trip Tracker” will be the task within Shift2Rail JU that will assist a traveller throughout his multimodal journey with technologies which accurately and timely notify travellers of any foreseen difficulties on their individual trip and offer re-arrangement solutions by providing alternative routes to limit impacts of delays. By shielding the travellers from disruptions, Trip Tracker will contribute to key objectives of the Shift2Rail Master plan:

#### Improve perceived reliability

- Unprecedented level of comfort for the traveller
- Multimodal alternatives presenting best and most flexible choices
- Reliable “guardian angel”

#### Customer experience

- Automated information of disruptions so that the travels does not to take care of his journey
- In multi legged journeys information regarding the next or the leg after the next leg
- Increase trust of the traveller due to reliable real time information

#### Enhance capacity

- By automated proposals of alternatives the flow of travellers within the whole network can be influenced
- By influencing the flow the capacity can be enhanced
- This in turn rises the customers experience

#### Reduce operating costs

- Operators are release from manually calculating and finding out of new alternative multimodal routes



- Reduction of queues at helpdesks

#### Externalities

- Increase marketing effect as it keeps the customer up-to-date especially in case of problems for inter cross boarder trips
- Contribution to the objective of greener transport by promoting modal shifts

#### Respect and adaptations of TSI

- To maximise the journey tracking capabilities adaptations to TAP TSI will be proposed
- Existing standards will be taken into account

#### **Definition and justification of the objective**

The Travel Companion is the frontend of the new intermodal travel experience that helps travellers to plan their journey and to be guided during their journey. It acts as a window and a “simplifying shield” to the complex and varied world of modals, travel experts, real time data etc. etc. The Trip Tracker in this environment is working as subtask in the background if the traveller wants to be assisted during his journey. Once activated the Trip Tracker works as a data sink for all travel experts noiseless and not being noticed by the traveller. It is responsible to provide the traveller with alternative routes in case of disruptions.

Data base for the Trip Tracker is not only the real time base of the travel experts. It as well has to take into account the preferences of the specific traveller. This is due to all possibly effected routes of all travellers. One of the challenges of the Trip Tracker is not only to calculate whole new itineraries in a door to door multimodal approach after a disruption occurs but from the current position or even only single legs.

This TD addresses some of the main obstacles for the deployment of multimodal travel tracking solutions across modes, providers and geographical areas:

- The limited availability of travel and traffic data across modes, services providers and geography
- The limited accessibility to good quality real-time data from reliable sources
- The absence of interoperability mechanisms between existing specialised tracking services
- The limited access to private traveller information, preferences and localisation
- The lack of readiness of the technologies for processing of very large amount of real-time data

Trip Tracker will analyse and correlate available static data (such as timetables, topologies), dynamic data (such as traffic updates, operational feeds, social networks) and passengers’ data (such as preferences, itinerary, locations). Relying on the TD4.1 Interoperability Framework to interface with the global transport ecosystem (TD4.1), Trip Tracker will benefit from the vast variety of data sources available on the open-ended “web of transportation” including social media information.



The following table presents the objectives of the Master Plan and the contribution of the TD 4.4 activities to their achievement.

Objectives		Contribution of TD4.1
<b>Improved services and customer quality</b>	Improved reliability	<ul style="list-style-type: none"> <li>Personalized passenger information taking individual preferences into account</li> <li>Using Up to date real time information guaranties best proposal of alternatives routes</li> <li>Using multimodal travel experts guaranties best choice for alternative routes</li> </ul>
	Enhanced capacity	<ul style="list-style-type: none"> <li>Reliable journeys will persuade more customers to use public transport</li> <li>Statistical data will enable operators to improve the allocation of railway capacities</li> <li>Statistical information of disruption data will direct the sights at critical parts of the infrastructure (network and or interchanges) and thus improve reliability</li> </ul>
	Customer Experience	<ul style="list-style-type: none"> <li>Guided journey across all possible means of transport</li> <li>Automated information</li> <li>Automated cost free list of alternatives</li> <li>Providing information on the mode specific passenger rights</li> </ul>
<b>Reduced System Costs</b>	Lower investment costs	<ul style="list-style-type: none"> <li>Reduction of overall infrastructure costs due to one communication layer between customer and several transport operators</li> </ul>
	Reduced operating costs	<ul style="list-style-type: none"> <li>Prevent queues at counters</li> <li>Reduction of service time for customers on trains</li> <li>Overall optimisation of vehicles due to optimised guidance of passengers</li> </ul>
	Externalities	<ul style="list-style-type: none"> <li>Carbon footprint will be reduced automatically due to propose optimal alternatives</li> </ul>
<b>Enhanced interoperability</b>	Respect and adaptation of TSIs	<ul style="list-style-type: none"> <li>Tracker is taking care of interoperability and accessible routes due to...</li> <li>... usage of interoperability preferences which may be adjusted and advanced</li> <li>Potential proposal for TSI amendments in respect to preferences</li> </ul>
	Removal of open-points	<ul style="list-style-type: none"> <li>Seamless door to door travel have to include accessible connections to non-rail means of transport; these issue can be addressed either in travel shopper and in trip tracker</li> </ul>

Objectives		Contribution of TD4.1
Simplified business processes	Improved standardisation	<ul style="list-style-type: none"> <li>Up to now several associations, operators, organisations, research and the like have defined more or less their own vocabulary to describe transport business. Within this project a complete unique set of vocabulary will be defined in a glossary, build on existing ones (e.g. passenger rights regulation, TAP TSI) and yet will improve standardisation</li> </ul>
	Simplified certification and authorisation	<ul style="list-style-type: none"> <li>In case of disruption travel shopper is automatically activated to gain alternative routes for the customer</li> <li>Tracker activates a proofing-process (TD4.3) to check if the existing tokens and entitlement are valid for the new route</li> <li>If necessary new entitlement will be generated automatically</li> </ul>

#### 4.5.4.2. Technical ambition of the Trip Tracker Demonstrator

As explained in the previous section you are more or less left alone during your journey, in nowadays travels. If any kind of exception occurs you as the customer of the transport operators have to pay attention on the further steps of your itinerary. Although there are some solutions in the market that gives proper information but still the customer have to type in specific information regarding his individual journey.

Some few examples may illustrate this:

- To be well informed and updated about the current state of your itinerary you have to have multiple interactions with different transport operators and to subscribe this information services separately for each operator.
- For each transport operator a customer have to become a client and have to subscribe to get information
- Even if push-notification for disruptions is activated the traveller has to type in his actual leg
- If you are travelling intermodal you as traveller have to change the information-centre according to your actual leg.
- If your disruption occurs at the end of one modal you personally have to switch between two operators (you have to take the actual disruption and to call with this information the following operator)

In addition to this there are some general problems and ambitions that can be faced for the trip tracker and have to be solved to provide best proposals for customers.

- Which case of changes of states travellers have to be informed?

- How can I minimise the amount of information to prevent that customers might miss an important message?
- The smart device must high precisely be informed about its actual position which is not necessary true for the traveller. Therefore two communication channels have to be established and checked.

Having this in mind Trip Tracker will be able to unify data from an open-ended range of sources though the interoperability Framework (TD4.1) allowing not only scalability and dynamic re-organisation of planned timetables across modes but also access to near real-time traffic data. This approach will significantly increase the tracking possibility as the volume of machine useable data will be potentially limitless. Trip Tracker will also take advantage of the emergence and availability of social media technologies which allow travellers to report events as they happen and therefore to act as valuable sources of information when conventional traffic control systems sources are unavailable. By applying complex event processing technologies, Trip Tracker has for ambition to go much further than the association of static timetables with current status of the transportation means and provide the capability to:

- Identify patterns in the transportation operations and to predict with accuracy future irregularities, thus pre-empting mitigation actions to safeguard the traveller's trip before the advent of the disruption itself.
- Deduct complex consequences of associated events to identify the cascading effects on a particular individual trip, thus organising a timely response.
- Take individual temporary preferences into account resulting in very complex process of calculating and offering optimal alternatives.
- Work in near real-time across a very large and open-ended set of data with potentially conflicting information and emanating from sources not necessarily intrinsically real-time. This requires simultaneous evaluation of multiple sources and complex decision making algorithms.

#### **4.5.4.3. Specific Demonstration activities and contribution to ITDs/SPDs**

One of the essential demands today's travellers have is an absolute easy to use transportation system. Unlimited modals, seamless connections and in particular a reliable guidance in case of disruptions are essential to shift humans from private to public transport. Trip Tracker will demonstrate that based on open-ended world of data, combinations of "endless" list of achievable operators and travel experts this reliable guidance can be achieved.

During the project a user scenario will be defined in which not only a multi modal seamless journey will be determined but as well disruptions with proposals of alternative routes. These disruptions will be simulated based on real time data.

The Trip Tracker Demonstrator will be developed up to TRL5 whereas the Technical Demonstrator will target TRL6. It is planned to deliver four main releases. First Release will be the one delivered as final release by IT<sup>2</sup>Rail in October 2017 (end of the project) which will be the basic demonstrator for Shift2Rail. Within Shift2Rail there are three releases planed with the last one early 2022. The releases



will be developed and delivered in close cooperation with the TDs Shopper, Booking and Companion to assure that the overall defined functionalities per release can be demonstrated. Fine alignment regarding the functions due to the user story and user needs will be part of the project.

#### **4.5.4.4. Impact**

The main benefits that Trip Tracker will bring for customers convincing him to shift from private transport to public transport include:

- Release the traveller from checking several sources and data bases in case of a disruption
- Release the traveller to find a new Route on his own
- Release the traveller from the task to check all tokens and entitlements on validity regarding the new selected route
- Propose optimal routes for the customer in respect to costs, time and convenience due to his personal preferences

Not only the customers will benefit from the Trip Tracker but as well an impact for operators and service providers can be seen.

- On the quality of services and the modal shift to public transport

Trip Tracker will contribute significantly to improve the quality of services offered to the travellers of European multimodal trips. By improving perceived reliability of the transportation system, especially in the Rail and Urban modes, offering Customer targeted information and re-arrangement mechanisms, and finally allowing operators to enhance the capacity of their infrastructure, Trip Tracker will promote the attractiveness of rail services and contribute to modal shift to Rail.

- On the creation of new transportation services

Trip Tracker enabling technologies will create new business opportunities for services providers offering services dedicated to specific modes of transport (e.g. car sharing) and specific categories of travellers (e.g. reduced mobility travellers) in order to cope in the most efficient manner with disruptions. Disruptions could be considered as opportunities as they will trigger a load balancing towards other modes of transport and generate revenues from travellers ready to pay a premium for re-accommodation.

- On the acceleration of European inter-modal schemes

As more travellers will rely on the Trip Tracker services, operators and services providers will have to deal with an increasing number of re-accommodations potentially outside their own network and contracted arrangements. To benefit from this situation, inter-modal agreements authorising rearrangements between operators could be put in place offering to the travellers even more reassurance and limited exposure to additional risks and costs.

- On the optimisation of planning rules for multimodal transport

Through the capability of Trip Tracker to identify disruption patterns and potentially through the feedback triggered by Trip Tracker to travellers and business analytics (TD4.6) services, a better understanding of network difficulties, bottlenecks and bypassing strategies will emerge. This will in turn allow operators, services providers and policy makers to optimise their offers and to propose a fine tuning of planning capabilities within the Travel Shopping multimodal services (e.g. connection times between modes at a specific bottleneck station could be increased to cope with regular disruption).

#### 4.5.4.5. Implementation of the work programme

The Trip Tracker within IP4 is a background task that can be activated manually by the traveller for each journey or automatically based on the individual settings of the customer. Trip Tracker interacts with several TDs which are:

TD4.2 – Shopper -> to request alternative Routes in case of a disruption

TD4.3 – Booking -> to check if the actual tokens and entitlements are still valid for the selected new routes

TD4.5 – Companion -> to inform the traveller about disruptions occurred and to present alternatives routes

Based on TD1 – Interoperability Framework – it is one of the fundamental tasks giving the customer new reliability pleasures and experiences for his journeys. The following diagram shows the various tasks that have to be performed and realised:

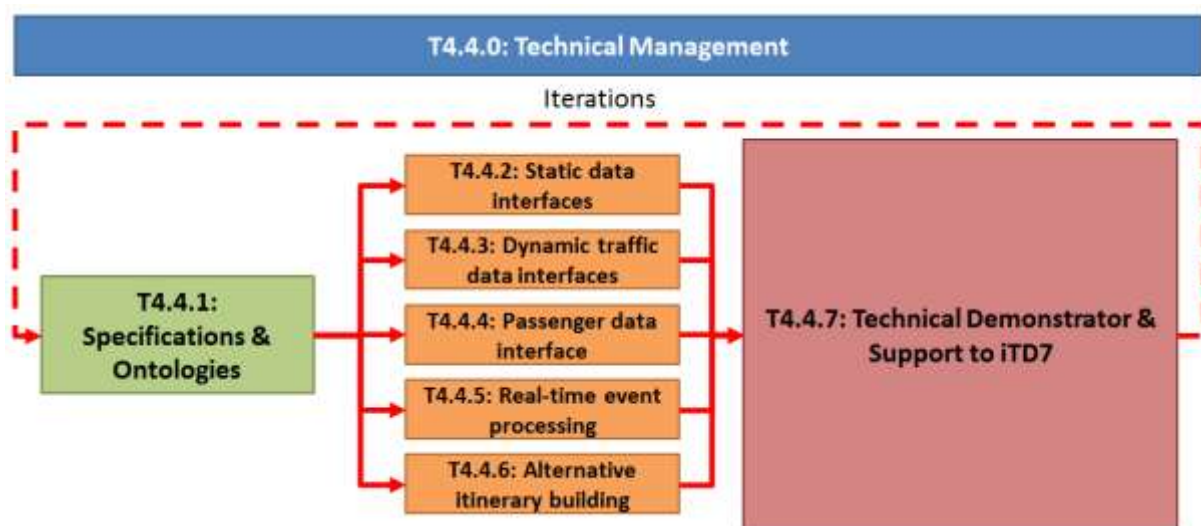

#### Task 4.4.1: Specifications & Ontologies:

Within this collaborative task, the contributors will define an exhaustive vocabulary of semantic terms (ontology) common between transport modes, with the formal description of key objects, roles and concepts shared by the Trip Tracker, and compatible with the existing legal environment (e.g. TAP TSI). This ontology will subsequently be provided to the TD 4.1 ontology repository for consistency checks and global access by the ecosystem.





This task will produce an open specification of all functions of the Trip Tracker which meets with the traveller's requirements for being always up to date and well informed before, during and after his travelling, involving the selection, engineering, and documentation of possible solution's architecture and technologies.

#### **Task 4.4.2: Static Data Interfaces:**

Relying on existing data formats and data communication standards and protocols the aim of this task is to develop software components to collect, across the transportation ecosystem, published static transport data related to planning, scheduling, topology, etc. and enhance them to deal with all modes. This interfacing will also be able to rely on the Interoperability Framework (TD4.1) to access the semantic 'Web of Transportation'.

#### **Task 4.4.3: Dynamic traffic data interface:**

Relying on existing data formats and data communication standards and protocols the aim of this task is to develop software components to collect, across the transportation ecosystem, published dynamic / real time data and enhance them to deal with all modes. This interfacing will also be able to rely on the Interoperability Framework (TD4.1) to access the semantic 'Web of Transportation'.

#### **Task 4.4.4: Passenger data interface:**

The contributing parties will define an interface and develop software components to process traveller's information (itinerary, route, preferences, current status, localisation, etc.) and provide feedback from Trip Tracker to the traveller (alerts, disruption information, alternative itinerary, etc.) The interface to the Travel Companion (TD 4.5) to interact with traveller's virtual spaces and smart device applications will be defined and implemented. Integration with Passenger Information Systems at stations/on-board should also be considered in order to display the information.

#### **Task 4.4.5: Real-time event processing:**

With this task a number of software components will be specified and developed to analyse potential impacts of disruptions (real-time changes and events to published data, schedules, topologies, etc.) on the traveller's itinerary and decide on the need for alternative itinerary construction and alerts to the traveller. Therefore all accessible information (static, dynamic and passenger data) will be interpreted in order to identify travel conflicts and their impact on individual transport connections, based on user's preferences, and the traveller will be informed about risks of deviation from the original itinerary and possible alternatives.

Different blocks of event processing for different modes and types of operators for each leg and interchange need to be orchestrated to allow combination of public transport knowledge bases with individual transport monitoring systems in order to establish an intermodal event processing.

Identified open call: Distributed solution for complex event processing (CEP) (including specification for this issue).

#### **Task 4.4.6 Alternative itinerary building:**

This task will provide an implementation of the alternative retrieval functions in charge of interfacing the Trip Tracker with the Travel Shopping (TD4.2) in order to obtain suggestions on alternative itineraries once a disruption has been identified.

#### **Task 4.4.7: Technical Demonstrator & Support to ITD 4.7**

This task is the link between the TD4.4 technical demonstrator and the overall IP4 demonstrator.

It consists in the integration of all implemented software components of Trip Tracking across all information of all modes to produce a Trip Tracking Technical Demonstrator. Ensure convergence of all internal and external interfaces, performances and functionalities and to ensure a smooth integration into the IP4 ecosystem. This integration will be monitored by ITD7, in charge of the system level release, integrating all inputs from the different TDs.

#### ***4.5.4.6. Planning and budget***

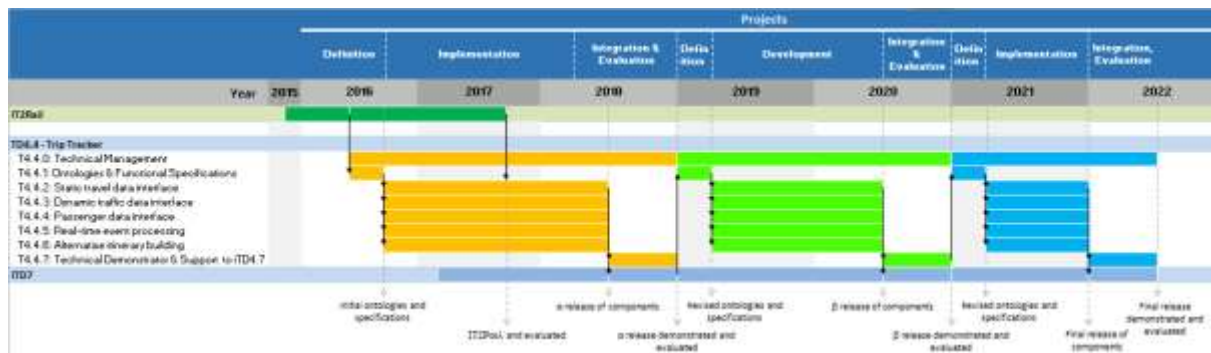

The estimated total budget for TD4.4 is around 10.01M.

#### **4.5.5. TD4.5 – Travel Companion**

##### ***4.5.5.1. Concept and objectives***

The 21st century travellers have high expectations for efficiency and low tolerance for barriers to mobility<sup>13</sup>. They are increasingly technology savvy, connected, informed, one could even say addicted to new technologies, which is particularly true for young generations. They have more and more difficulties to accept the multiplication of heterogeneous services, the seams not to say the gaps between them, as well as the lack of information, assistance, and flexibility during their journey.

On the other hand, information technologies have recently made significant progresses especially in the field of mobile applications. Smart devices have been massively adopted by travellers for communicating, gaming, audio/video media and web browsing during journeys. The idea of providing applications and new devices to improve the traveller experience is hence maturing. As a first result, mobile “apps”, provided by transport operators, regions, travel agencies, communities and travellers’ forums, etc., are today proliferating to provide information or services to travellers. However, a more

<sup>13</sup> Smart Travel Unlocking Economic Growth and Development through Travel Facilitation, World Economic Forum, June 2014

in-depth analysis reveals that these “apps” are actually very limited and not yet massively adopted. They are indeed very fragmented and do not bridge the gaps between services such as shopping, booking, ticketing, etc. Global seamlessness for door-to-door multimodal travels at European scale, as ambitious by IP4, is hence not accessible. In addition, they take the form of desktop applications ported to a mobile system without exploiting all the potential of the new advances in the fields of man-machine interfaces, mixed realities, smart devices, ambient intelligence, big-data and cloud computing, geo-positioning, environment sensing (including through crowd sourcing, social networks, and the ubiquitous ‘web of things’). These make however possible the emergence of new forms of travelling experiences enabled by an adaptive and engaging mobile, pervasive, and interactive framework designed to guide, support, assist, inform or even entertain travellers during multimodal door-to-door journeys.

The overall objective of TD4.5 is to research, implement and evaluate a seamless and interoperable platform offering new levels of interaction between travellers and transportation stakeholders along with an innovative ubiquitous adaptive front-end to the global transportation service ecosystem. From the traveller’s perspective, it will enable the creation of interactional trajectories involving travellers in Mixed Reality experiences unfolding as narrative structures along their multimodal journey and adapting to their profile, constraints, behaviour, potential disabilities, as well as to the real-time situation (e.g. events, incidents, weather). These trajectories will shield the users from the complexity of the multimodal travel and the fragmentation and heterogeneity of services by enabling the ubiquitous access to all IP4 services through a homogenous interactive environment. Conversely, with a direct access to the traveller, operators and service providers will be able to better understand travellers’ needs and address them in the most appropriate and cost effective manner.

**Figure: mixed reality experience, using different devices (right).**



This TD will address some of the main obstacles to enhance the travel experience and benefit from new connected technologies:

- The impediments for all stakeholders to access, share and interact with travellers’ data.
- Reluctance to sharing customer data by actors benefiting from the current fragmentation.
- The unequal capabilities of network validation infrastructures across modes and stakeholders which require different means to navigate the network.



- Lack of innovative SMEs and new services due to limited accessibility to shared data and services.
- Fragmented approaches and technologies to communicate with the travellers.
- Limited interoperability between customer-oriented services which are not seamlessly integrated.

The Travel Companion will associate a unique identifier and a profile to each traveller within a protected and secured data store in the cloud. By mean of this identifier, both traveller and transportation ecosystem can access electronic wallets to interact securely and ubiquitously. Whilst the wallets infrastructure is managed by the Travel Companion, the lifecycle of data contained in the wallets is handled through the relevant IP4 TDs.

For a seamless and comfortable journey, the travellers will access the secure data store element of the Travel Companion through their smart devices. Relying on the results of TD4.1 Interoperability Framework, applications proposed on the smart devices will allow the traveller to experience a digital, customized, integrated and operable representation of a seamless transportation environment shielded from differences in local protocols, procedures, customs or physical facilities and unfamiliar access to validation devices.



The following table presents the objectives of the Master Plan and the contribution of the TD4.5 activities to their achievement.

Objectives		Contribution of TD4.5
<b>Improved services and customer quality</b>	Improved reliability	Enabling a high level of connectivity and interaction with the travellers using their services and infrastructures will allow the ecosystem providers to adjust effectively their offers to specific situations, profiles, and behaviours of travellers, adapting services and information to limit unplanned disagreements, thus maintaining user's confidence.
	Enhanced capacity	Delivering dynamic tapping/validation mechanisms, automatically adapted to match network infrastructures and traveller connectivity capabilities, as well as offering navigation at interchanges and positioning information will ease the throughput of passengers within transportation hubs and stations enabling the optimisation of the flow of travellers in congested areas.
	Customer Experience	Reinventing the traveller experience by shielding her/him from complexities and heterogeneity of the different services available along a trans-modal door to door journey. This will be achieved by delivering homogeneous, ubiquitous, and adaptive user interfaces as well as new concepts of user experience.
<b>Reduced System Costs</b>	Lower investment costs	Delivering best practices, lesson learned, as well a set of tools and an open platform that will enable the development of next generation traveller services faster and at a lower-cost.
	Reduced operating costs	Contributing to the full dematerialisation of transport services thanks to cloud computing and smart devices capabilities. Through ubiquitous access to travel rights in electronic wallets and sophisticated tapping devices, services, providers and operators alike will be able to manage the transportation journey within a dematerialised ticket environment, thus significantly reducing their infrastructure costs
	Externalities	Providing travellers with a more direct access to the global multimodal transportation offer thus encouraging behavioural changes toward carbon-wise transportation choices.



The following table presents the technical results of the TD4.5.

Result	Description
User needs, scenarios and best practices	<p>This deliverable will provide a consolidated analysis of the end-user (travellers, operators, service providers) requirements, of the current state-of-the-art as well as the best practices and envisaged scenarios. It will be exploited to prepare the functional specifications and ontologies used to develop the TD4.5 components.</p> <p>Proposed KPIs:</p> <ul style="list-style-type: none"> <li>• Nb of users involved in the requirements definition</li> <li>• Nb of user categories involved in the requirements definition</li> <li>• Nb of state-of-the-art items studied</li> </ul>
Functional specifications & ontologies	<p>This deliverable defines the functional specifications and ontologies required to implement the various TD4.5 components.</p>
Secured Cloud-based platform	<p>This result is the main cloud-based platform hosting each travellers' virtual space, including ID, profile, preferences, payment means and tickets, etc.) as well as services available to her/him and background processes required, for instance, for the dynamic profiling of the user or the orchestration of her/his experience.</p> <p>Proposed KPIs:</p> <ul style="list-style-type: none"> <li>• Nb of users supported</li> <li>• Nb of services supported</li> <li>• Nb and complexity of supported processes</li> <li>• Level of security and privacy</li> <li>• Robustness and resilience</li> </ul>
Traveller Profiler	<p>This component will be in charge of analysing in real-time the behaviour, actions and interactions, as well as trajectories of the traveller to define and keep up-to-date her/his corresponding profile in order to adapt the user experience accordingly.</p> <p>Proposed KPIs:</p> <ul style="list-style-type: none"> <li>• Relevance of the profiling</li> <li>• Required CPU load</li> </ul>
Next-generation traveller Services and related tools	<p>This result will be a collection of new forms of location-based experiences aiming to make travels more engaging and attractive as well as homogeneous and innovative multimodal user interfaces enabling travellers to ubiquitously access heterogeneous services such as Travel Shopping, Ticketing and Trip Tracking.</p> <p>This also includes a set of tools (SDK, IDE) required to rapidly prototype, develop, and publish such services, to animate the evaluation scenario, and open the system to third-party developers thus fostering the adoption of the whole IP4 results.</p> <p>Proposed KPIs:</p> <ul style="list-style-type: none"> <li>• Quality of the user experience (Motivation, Pleasure, Satisfaction, Clearness, Intuitiveness, Availability, Usefulness, Accuracy)</li> <li>• Number of offered services</li> <li>• Cost/time to implement new services</li> </ul>

Result	Description
Interoperability modules	<p>These modules will enable the interoperability between the platform or the services with external and devices and services.</p> <p>Proposed KPIs:</p> <ul style="list-style-type: none"> <li>• Number and relevance of the supported devices</li> <li>• Number and relevance of the supported services and standards</li> </ul>
Indoor/Outdoor Positioning and Navigation system	<p>This result will include a navigation app and the underlying positioning infrastructure supporting indoor and outdoor environments, as well as the seamless transition between both.</p> <p>Proposed KPIs:</p> <ul style="list-style-type: none"> <li>• Effectiveness of the navigation assistance within complex environments such as the largest railway stations and train interiors.</li> <li>• Positioning precision in any environment, including crowded ones.</li> <li>• Size and complexity of the geospatial datasets supported (railway stations, trains, ...)</li> </ul>
Tapping modules	<p>This result will enable to use the travel rights stored in the travel wallets for validation and inspection purposes by field devices within heterogeneous operators' infrastructures.</p>
Evaluation and learned lesson reports	<p>This major result provides the evaluation results of the TD4.5 Travel Companion. It also includes the evaluation framework that precisely define what and how results will be evaluated, including with which datasets and users. It is phrased in a way simplifying its exploitation to refine next release requirements and specifications.</p> <p>Proposed KPIs:</p> <ul style="list-style-type: none"> <li>• Nb of users involved in the evaluation</li> <li>• Nb of user categories involved in the evaluation</li> </ul>

#### 4.5.5.2. Technical ambition

Today, when looking at the travel sector, one could easily consider that there is no need for yet another “travel companion” when seeing the proliferation of “apps” that claim to offer this concept. However, a more in-depth look at the possibilities of these latter leads to the conclusion that all of them are actually extremely limited and shallow. They generally offer a very simple, even though helpful, service to the traveller when a high-level of “revenue” (either directly through sales, or indirectly through advertisement or slightly reduced operating costs) is expected from local actors of the transport business.

In terms of functionalities, these apps are often extremely limited. Compared to the IP4's main objective of seamless end-to-end travel across Europe, they all fail short in delivering a service that would be both multimodal and actually end-to-end. In all fairness, the issue does not come only from the “app”, but also from the services and infrastructures it is based on, which are often limited in scope, concept, and are almost always encompassing only one of areas such as travel search, sales, ticketing, and journey tracking.

In comparison, the aim of IP4 is extremely ambitious: By providing high-level integrated services such as Travel Shopping, Ticketing and Trip Tracking, IP4 will have the capability, from the traveller's perspective, to bridge the gap between these areas. And this is fundamental for the Traveller, for





only then will he have the actual support for his/her end-to-end travel, from the time he envisions her/his travel to after the travel itself, exploiting all relevant means of interaction to experience an engaging and ubiquitous service covering all the intermediary steps of finding the best way to travel, acquiring the rights, actually travelling and being supported, informed or even entertained all along the way.

Moreover, despite the depth of the intermodal functions developed in the functional TDs of IP 4 (in particular TDs 2, 3 and 4), these would not be sufficient to provide the traveller's experience of seamless travel: the seamlessness must come from the devices used to interact with the rest of the IP4 system all along the journey.

Hence the very criticality of the Travel Companion relates to the redefinition of the traveller experience that will enable to assess the validity of the IP4 approach: only by taking into account the traveller's actual requirements, and providing him with the efficient and user-friendly tools required for a seamless experience will the Travel Companion succeed in show-casing the end-to-end seamless mobility across Europe. The Travel companion TD, seen as a whole, will define and solve all the issues surrounding the interaction with the other TD's but also what lies behind decoupling of the travel entitlements. This covers the security in the cloud, the shielding of all objects managed in the cloud, with an access "as appropriate" for all participating entities (other TD's, Transport service providers, payment providers...).

And this hinges on as delicate elements as those that made Apple the success it has been these past few years. Today, success on almost any market is no longer merely due to the market approach, or the technical ingenuity in itself. Thanks to a lightning-fast spread of opinions across the entire population (social networks), qualities, defaults, and perceptions are quickly resonated and amplified across all the users' base.

To succeed the Travel Companion will therefore not only need to successfully integrate the multimodal end-to-end capabilities of the functional IP4 TDs, it will not only need to do this in a radically new manner that also satisfies European rules and regulations (and in particular privacy and security), but it will need to do this in a manner that will convince the vast majority of travelers that there is true innovation as well as new concepts and capabilities ready for adoption. And this is where, in addition to the fundamental concepts of the IP4, the comparison with the limited, non-ergonomic; current "travel companions" will make the breakthrough even more spectacular.

This is a considerable challenge. Despite the significant breakthroughs expected of the Travel Companion, it is nonetheless well supported by the rest of the IP4 concepts, in their multimodality, and overall approach to seamless end-to-end travel. However, in order to support these concepts, and in order to make them appealing to travelers, the Travel Companion needs to be more than a simple technical orchestrator of travel functions, it must aim at becoming a complete mixed reality experience shielding the traveller from the heterogeneity and seams in the different services and making a journey across Europe more effective, engaging, hence attractive.

#### **Current major technical limitations and ambition**

A number of technical limitations pave the way toward the envisaged Shift2Rail Travel Companion concept.





First, integrating the multiple heterogeneous services available to the traveller across multi-modal, door to door journeys, in the form of a seamless, homogeneous, and ubiquitous experience is today far from reach. This first requires a radical conceptual shift in order to consider the user's experience as the final product. This also requires the definition of a common cloud-based platform supporting a massive number of users and offering appropriate interoperability capabilities as well as the tools and building blocks required to enable the rapid and cost-effective development, and future adoption, of the next-generation services and devices used to materialise the user's experience.

In addition, delivering an effective and engaging experience will require to rethink the traveller experience and introduce new principles borrowed for instance from research domains such as interactive storytelling and mixed reality in order to orchestrate a trans-modal journey and turn it into an engaging and effective experience. For that purpose the dynamic analysis of the traveller's behaviour, actions, and trajectories to update her/his profile and adapt the produced experience to her/his situation, environment, and abilities will be of significant value. Dynamic profiling and experience adaptation are however extremely complex tasks that have been recently explored in research projects with high success to produce attractive experiences easily adoptable by the general public.

Indoor positioning of travellers and communication with their devices in all situations are also of the highest importance in this context. The main issue here is to create an effective, low-cost indoor positioning infrastructure that will also enable seamless transition from/to outdoor environments. It is a very challenging domain as well as one of the major market enabler for next-generation location based services. Unfortunately, there is no ideal solution and, today, only a combination of several technologies can be envisaged to offer sufficient robustness and accuracy.

Indoor navigation is also far more complex than outdoor/car navigation assistance as graph-based and particle filtering methods are barely adapted to the free movements of pedestrians in such environments. In addition, indoor navigation support require new approaches because of the three-dimensionality and geospatial complexity of such environment where rooms, walls, floors, corridors, stairs, elevators are some of the elements that need to be consider in order to deliver effective indications.

Adding up all the proposed innovations is not only a challenge in terms of integration, it also require to radically change the way user interfaces are conceive and exploit the latest advances in this man-machine interfaces to deliver a seamless, homogeneous, and ubiquitous experience along the whole journey. The challenge here, beyond usability issues, is also to maintain the consistency and continuity of the experience all along the journey, using different devices and services. This also require to study visual and interaction metaphors exploiting the various devices populating the traveller's environment to deliver the right information at the right time, while minimising the cognitive load to maximize both the usability and transparency of the system.

Finally, one of the main underlying technical challenge of TD4.5 is to design and create a new generation of tools that will enable the rapid creation, publication and experiencing of these next-generation location-based experiences. This is mandatory to foster adoption, further extension, and maturation of the Shift2Rail research results. This will also offer the required flexibility during the project to envisage and rapidly evaluate various approaches and solutions.

Results from research projects such as SMART-WAY (<http://www.smart-way.mobi/>), IT2RAIL (<http://www.it2rail.eu/>), SUNSER ([http://cordis.europa.eu/news/rcn/35869\\_en.html](http://cordis.europa.eu/news/rcn/35869_en.html)), VIAJEO ([http://www.viajeo.eu/en/about/viajeo\\_partners/](http://www.viajeo.eu/en/about/viajeo_partners/)), SUPERHUB (<http://superhub-project.eu/>), MOVEUS (<http://www.moveus-project.eu/>) or CHESS (<http://www.chessexperience.eu/>) - for significant breakthroughs in the field of adaptive tourist experience will be carefully analysed to exploit any potential complementarities and interesting contributions, including evaluation results and lesson learnt, in order to guarantee significant progress beyond the state-of-the-art.

#### **4.5.5.3. Specific demonstration activities and contribution to ITDs/SPDs**

The TD4.5 “Travel Companion” will demonstrate an innovative adaptive, interactive, and ubiquitous framework for next-generation traveller multimodal door-to-door experiences. The demonstration will federate several services made accessible through a homogeneous user interface exploiting the multiple devices populating the traveler’s environment. It will make use of hardware devices in a simulated operational environment.

The exact demonstration scenario will be defined by the partners in close cooperation with end-users from both the general public, as travellers, as well as the stakeholders and service providers. It will cover the full extent of the user experience from the journey planning phase until arrival at the final destination location, using different transportation modes, and coping from disruptions, solicitations, advert events as well as changes in the original travel plan. Operational scenarios will envision the aggregation and homogenisation of heterogeneous services and their experiencing on the move using modern as well as future interactive devices.

As a result, the demonstration will target TRL5 with a prototype demonstration in a relevant environment. The TD4.5 prototype environment will simulate an operational environment in terms of quality of service (positioning and telecommunication issues) as well as situational uncertainties (e.g. incidents, disruptions, plan changing).

TD4.5 prototype will prove the interoperability scheme between service providers with full extent of the operational scope. It includes different kind of degraded modes, technical to address resilience but also operational such as claim or refund use cases.

The successive releases of the TD4.5 prototype will be fully integrated into ITD4.7 demonstration in order to provide an essential part of the user interface between the traveller and the transportation ecosystem (e.g. services, operators). Although ITD4.7 will focus on the variability of business scenarios, TD4.5 demonstrator will focus more on operational scenarios as well as their consequences for the traveller and on, incidentally, the service providers and operators.

#### **4.5.5.4. Impact**

The TD4.5 – “Travel Companion” will deliver a major contribution to the enhancement of the attractiveness, user-friendliness, and feeling of efficiency of rail transport, thus contributing to its larger adoption. This will be one of the most impacting and visible results of the Innovation Programme 4, a system that will accompany users from door to door during all their travels, easing both access and use of services while turning any journey into a seamless and enjoyable experience adapted to the user’s profile, the evolving situation and accessible to those with disabilities and



reduced mobility. Incidentally, it will deliver a set of open tools, formats, protocols, guidelines and best practices that will be made available to the operators and service providers' eco-system in order to adopt and further extend the "Travel Companion" concept and capabilities while offering new sources of revenue.

- On the quality of the travelling experience and the attractiveness of public transport:

The capacity of the Travel Companion to alter for the better the traveller's perception of transportation eco-system and improve the quality and attractiveness of the travelling experience, from door to door, is one of the most significant expected impact. Within IP4, the Travel Companion will provide the traveller with a homogenised, seamless, and interoperable system delivering a sense of continuity in the transportation services along with adaptive and ubiquitous services. In opposition to the current fragmented service offer, and with the addition of advanced services, such as passenger information and indoor navigation assistance, and new pervasive door to door experiences and inputs from TD4.4 "Trip Tracker", the TD4.5 "Travel Companion" will provide the travellers with a better perceived reliability and service consistency in opposition to the current fragmented service offer.

- On the creation of value:

TD4.5 will deliver a unified open and interoperable framework, including a set of tools, APIs, as well as best practices, which will allow retailers and service providers to create new products and services for travellers, cheaper and faster as homogeneous and seamless extensions of the Travel Companion. These results will foster the emergence of new forms of location-based services with multiple possible business models benefiting from the simplified and more direct communication between travellers and multimodal service providers as well as from the unrivalled set of information collected about the travellers to deliver personalised experiences. Sourcing and investment costs in the development of advanced ICT solutions for travellers will also be decreased by the opening of a competitive market.

It is also expected that the enhancement of the traveller experience will redound in an increase in the use of railway and collective transport, providing benefits to operators and accelerating the adoption of S2R solutions globally.

- On the innovation curve for traveller services:

The first impact of the Travel Companion within the transport eco-system will be the appearance of additional user-centric services of new generation. As Travel Companion providers will compete, as the adoption of new technology and products is lightning-fast, Travel Companion providers will need to maintain a constant evolution of their product bringing new services offering additional innovative functionalities and supporting new devices to travellers. This will be made easier and more cost-effective thanks to the development tools and open platform delivered by TD4.5.

- On the diversification of sales channels:

As the sales processes are handled by the Travel Companion through the TD4.2 "Travel Shopping" and TD4.3 "Booking & Ticketing", the service providers and operators will have a



greater understanding of travellers preference and behaviour across modes and gain a better control over their sales channels in terms of costs and diversification.

- On the attractiveness for top-talents:

The Travel Companion technologies aggregates many innovative concepts and exciting new smart travel services. These will not only foster innovation as well as further demand for innovative technology solutions. It will transform the Rail Travel Industry into an attractor of top talents, which in turn will contribute to its modern image as well as its self-sustained ever-greening. Creating intelligent mobility services and the next-generation location-based experiences for travellers will become as gratifying as working in top-notch IT companies.

#### **4.5.5.5. Implementation of the work programme**

TD4.5 is one of the two pillars of the “Customer Experience Applications” research and innovation area of the Master Plan. It will generate the man-machine interface components enabling travellers to interact with multiple heterogeneous services along their journey in a homogenous and intuitive way. It will also produce a set of tools dedicated to the rapid and cost-effective development of such components, thus fostering the adoption of the Shift2Rail IP4 results.

Its implementation therefore must involve end-users, stakeholders, and domain experts as often as possible in the definition and revision of the user needs and function specifications as well as in the evaluation of the TD4.5 outcomes. It also requires tight collaboration with other Innovation Programmes’ TD that will have a direct impact on the traveller experience including future vehicle environment (TD1.7) and stations (TD3.11).

For that purpose it will adopt the general iterative methodology proposed in ITD7. This will be extended with intermediate releases in order to evaluate on a more regular basis the usability of the produced results from early prototypes to the final version.

All the functional specifications will be made public and the technical developments will be standard compliant and open in order to foster adoption and allow alternative implementations or extensions. Adoption of existing standards will be favoured wherever relevant.

Accessibility and interoperability are core for the specifications and design activities of the work programme. Appropriate organisation and processes must be set-up in order to collaborate effectively with the other IP4 activities and relevant TDs from other IPs (e.g. TD1.7, TD3.11).

A coherent task breakdown including interaction with other IPs and TDs is proposed for the successful implementation of this technology demonstrator. It properly considers the schedule of the H2020 Mobility lighthouse projects this project will cooperate with, and IT<sub>2</sub>Rail in particular, in order to optimise resources, respective collaborations, reuse and integration while maximising the mass of resources and expertise working in this critical R&I area, which is a necessary condition for European R&D efforts to have a real global impact in this market.

Figure 97: TD4.5 work breakdown

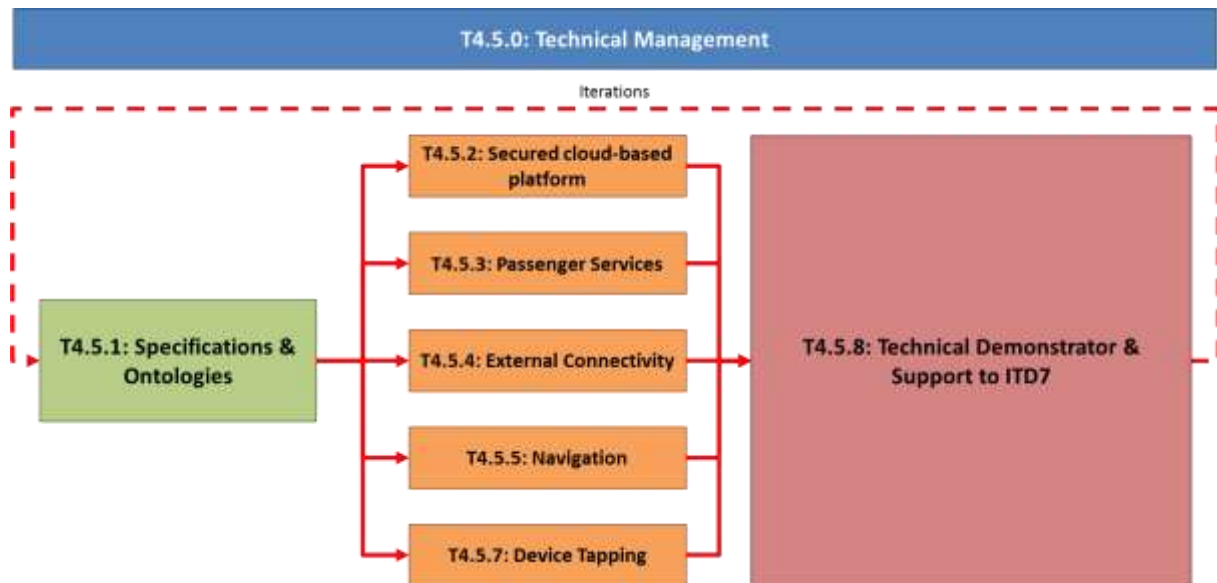

#### **T4.5.1: Ontologies & Functional Specifications**

Within this collaborative task, the contributors will produce an exhaustive definition of a vocabulary of semantic terms (ontology) common between transport (Urban, Rail, Air, Bus) modes, the formal description of key objects, roles and concepts shared by the Travel Companion components. This ontology will subsequently be provided to the TD 4.1 ontology repository for consistency checks and global access by the ecosystem.

This task also aims to identify, refine, and analyse the end-user requirements on a regular basis using initially early prototypes to foster the discussion with end-users and stakeholders and make them understand the potential of the technology and the research directions that can be envisaged.

This task will produce the use case scenarios that will complement the state-of-the-art analysis and the user requirements to produce the open specifications of the Travel Companion, involving the selection, engineering, and documentation of possible solution's architecture and technologies to match the requirements.

*An open call may be envisaged in order to organize the contribution of end-users in the definition of needs, the collection of datasets and the creation of the use case scenarios.*

#### **T4.5.2: Secured Cloud-based Platform**

This task will specify, develop, deploy, and manage the scalable and secured cloud-based platform that will be used to:

- Collect, aggregate, and store information about each traveller in real-time;
- Process this information and execute services;
- Deliver personalised interactive experiences adapted to each traveller.



This platform will be secured by design and will guarantee the preservation of privacy and safety of the data, including hot backup and restore capabilities. It will feature a scalable mechanism supporting a massive number of users and experiences, and enabling the execution of modules in charge, for instance, of:

- The real-time profiling of each traveller to adapt the service to her/his behaviour, skills, and available devices;
- The trans-modal orchestration of each user experience, from door to door.

This task will also develop a number of components in charge of managing the user's virtual space, profile, history, preferences and trip details, along with her/his unique identification within the Shift2Rail ecosystem and the access to the associated data. For that purpose, all personal information associated to travel conditions and overall behaviour during the journey (e.g. longer stays, delays) will be identified. The task will additionally deliver the software components for electronic wallets management dedicated to secured and expandable management of travel rights and payment means.

*An open call may be envisaged in order to contribute to the implementation of the dynamic profiling system for adaptive user experiences (not for the alpha).*

#### **T4.5.3: Passenger Services**

This task will design and develop a wealth of components that will enable the interaction of the user all along her/his journey with the Shift2Rail IP4 services, through the mediation of the TD4.1 "Interoperability Framework" and using wearable devices (e.g. smartphone, tablet, smartwatches, AR glasses) as well as other interactive devices populating the environment. This task will include the definition and modelling of modern human behaviour patterns enabling the Travel Companion as a natural extension of citizen work and leisure life. This will also include the definition of best practices and guidelines for the development of such services as well as a set of tools to simplify the development of these next generation location-based services.

The task will also invent and implement new interaction metaphors using these devices and their sensors to enable smarter, more ambient and transparent transmedia interactions.

Services such as shopping or booking will be implemented to demonstrate both the relevance and effectiveness of the proposed approach.

*An open call can be envisaged in order to provide high-class expertise in ethnography studies for traveller behaviours and their use of IT systems. This may also be placed in T4.5.1.*

#### **T4.5.4: External Connectivity**

This task will specify, design, and develop the components dedicated to the interaction between the travellers and the Travel Companion framework using smart devices as well as the smart objects (e.g. smartwatch, AR glass, public displays, iBeacons...) that populate their environment all along their journey.



It will also deliver the components enabling the Travel companion to interoperate with external applications (e.g. social networks, personal calendars, PIMS) used by travellers in their daily work and leisure life.

#### **T4.5.5: Navigation**

This task aims to specify, design, and develop the software components for geo-navigation functions available to the users in transit between modes of transports at interchanges or within infrastructures and transportation means. These components will provide adaptive and seamless indoor/outdoor navigation functions taking into consideration the traveller's preferences and potential disabilities.

This task will also develop components offering new interaction metaphors using multiple devices and innovative user interfaces such as augmented reality to guide the user along her/his journey.

An indoor/outdoor positioning system will be designed and implemented. It will rely on GNSS/EGNSS positioning as well as other potential means that offer sufficient reliability and accuracy within indoor environments. Seamless indoor/outdoor transition will be supported by the proposed solution.

Additionally, this task will develop an environment service that will aggregate, fuse, and store in an optimised way multi-source, multi-format geospatial data defining the traveller environment and enabling path planning and guidance. It will also build the datasets required for the demonstrations.

*An open call can be envisaged in order to provide disruptive tracking (e.g. for AR) and indoor positioning technologies.*

#### **T4.5.6: Device Tapping**

This task will specify, design, and develop the software components that will use the travel rights stored in the travel wallets for validation and inspection purposes by field devices within heterogeneous operators' infrastructures. The participants will specify and deploy automatic and simplified instantiation of dematerialised travel rights depending of the capability of the encountered transportation environment. Travel entitlements will be instantiated within operators network (Token) in electronic form and possibly converted into physical Embodiment if necessary. This task is linked with TD4.3 "Booking and ticketing" validation function.

#### **T4.5.7: Technical Demonstrator & Support to iTD4.7**

This task will integrate the results of tasks T4.5.2 to T4.5.7 into a common demonstrator presenting in a relevant environment the resulting system. This will include the travel companion system, surrounding and accompanying the travel during her/his whole journey, as well as all the tools developed in the frame of this TD to develop, debug, optimise, monitor, and evaluate the resulting system.

This task will perform both unit and integration tests as well as first usability assessments. It will ensure that all the designed interfaces, protocols, and interoperability means are operational and effective, that the delivered performances and robustness are satisfactory.



The results of the testing and usability evaluation activities will be exploited by all tasks of this TD to refine and improve the next release of their results

This integration will be monitored by ITD7, in charge of the system level release, integrating all inputs from the different TDs

#### 4.5.5.6. Planning and budget

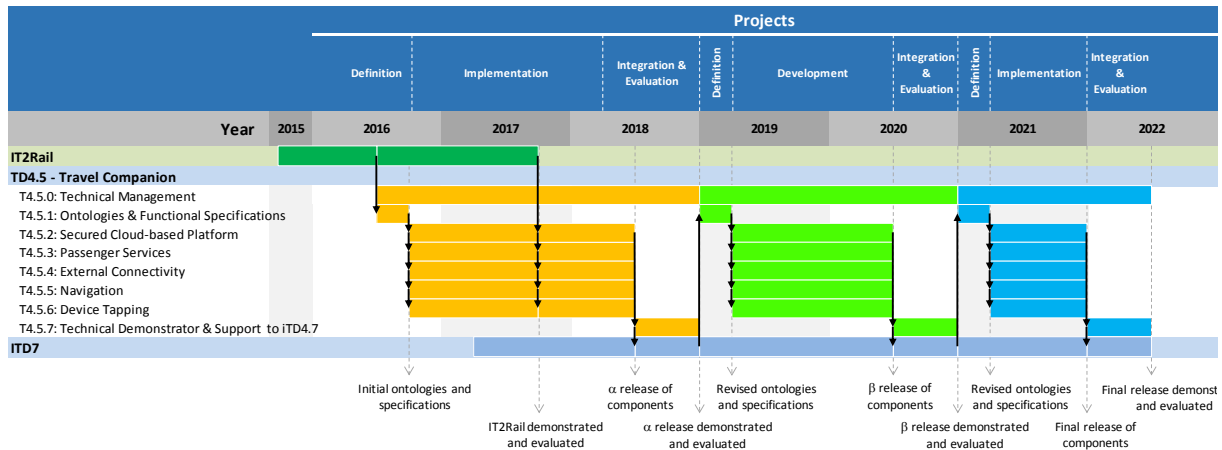

The estimated total budget for TD4.5 is around 12.5M€.

#### 4.5.6. TD4.6: Business Analytics Platform

##### 4.5.6.1. Concept and objectives of the Business Analytics Demonstrator

The rail sector and more specifically urban mobility is one area in which big analytics could soon be making a major difference. Public transport authorities and operators gather enormous amounts of data, for instance generated by transport smartcards. Big analytic approaches hold the key to getting more out of existing data and opening the doors to a more interconnected future, with deeper insights into passenger behavior, passenger flows and the ways in which travelers make use of infrastructure and equipment. These can be used to plan better infrastructure, introduce new services, provide targeted passenger information, refine tariffs – and even steer customer demand – with a far higher degree of certainty than has previously been possible.

TD4.6 “Business analytics platform”, part of the Technical Framework research area of IP4, will provide a common business intelligence foundation for all Shift2Rail transport product and service providers based on the access to open-ended web of transportation data offered by the Interoperability Framework (TD1). Providing means to generate and monitor data coming from the IP4 ecosystem, it will address some key objectives of the Shift2Rail Master plan:

- *Improved perceived reliability:* by providing the tools for operators and services providers to monitor, analyse and understand global travel flows associated not only to their own services but, critically, across the entire ecosystem, Business Analytics will offer the capability to model resilient travel multimodal services, adapted to the wide variety of travellers’ profiles and infrastructure environments, thus increasing the confidence in the IP4 ecosystem services.





- *Enhance Capacity:* with better insights in the travels patterns and preferences of their customers, across their infrastructures and considering the relationships with adjacent networks and transportation modes, operators will be in a position to deploy more accurate capacity planning tools and pre-emptive services to reduce congestions at stations and hubs.
- *Improved Customer Experience:* As services providers and operators get better and more correlated feedback from the ecosystem, including from the travellers themselves, they will be in an optimised position to propose new services and adaptations of current offers to better suit the travellers' needs. Complete understanding of their user's typology, preferences, payment patterns, etc., will allow the transit agencies to offer innovative transport products better matched with demand.
- *Lower investment costs:* as business analytics platforms offer valuable insights and feedback on services provided, they provide competitive edge and are fast becoming a necessary management and decision tool for the transportation ecosystem. It is the objective of the IP4 business analytics to enable the emergence of commonalities in the platforms technologies and data acquisition mechanisms to reduce current high investments necessary to benefits from those services.
- *Reduce operating costs:* with capability from the business analytics to perform predictive analysis on a vast amount of transport data, operators will foresee with greater accuracy required adaptation of their infrastructures to meet the demand and evolutions of travellers' behaviour. Exhaustive and enriched feedback will allow a more detailed base of KPIs and suggest operative actions/changes to services, based on the business needs to optimise lifecycle costs and increase revenues.
- *Externalities:* Through its global analysis capabilities of the European multimodal transport ecosystem, Business Analytics will provide an in-depth understanding of the transport modes usage and allow precise KPI reporting on global modal shifts to carbon-wise modes of transport, thus enabling the deployment of further green strategies.
- *Simplified certification and authorisation:* Business analytic has for objective to encourage the sharing of data between actors and competitors of the transportation ecosystem. Through the emergence of coopetition (completion and cooperation) schemes, operators and services providers will provide data which will gain in value through their correlation and enrichment with the rest of the ecosystem analysis. The mechanisms put in place will preserve economic sustainability of all contributors.

More specifically, the expected results are defined in the following table summarizing Objective – Result – Practical (Concrete) Deliverables:

Objective	Result	Practical Deliverable
Leverage social, mobile, structured and unstructured data to obtain valuable, actionable insights that allows rail operators, Shift2Rail ecosystem product/service providers, Traveller/ Transport Enterprises to make better decisions in order to increase quality of service and passenger demand.	Manage a large and complex set of data enabling an integrated door to door multimodal travel service distributed by multiple service providers. Collect and integrate historical business data (within IP4, from Ticketing) and travellers behavior on all channels (mobile, social, web, ...) (within IP4, from Travel Shopping, Companion, Tracker, ...), data generated by a wide variety of devices, sensors, social media, transactions to allow clearing-house among operators and dynamic personalized service in real time.	Travel & Transport Analytics
Help the passengers carriers to better adapt their level of service to the passengers demand and to optimize their operations in order to bring and retain more people on the train-urban mobility.	Improve customer interactions, service/product sales, service management, maintenance and rail attractiveness performance measurement in order to enhance quality of service and passenger demand.	Customers / Travellers Relationship Management
Better S2R services by deep knowledge and conversation intimacy with customers (consumer-travellers, business-enterprises) in order to improve service quality.	Mobile & web solutions and services to manage direct relationships channels (portals, blog, social media, ...) and made available «social web» tools to build relationships based on online conversations of S2R service users.	Social CRM/TRM
Increase passengers, improve quality of service and increase revenue enabling decision tools for rail and multi-transport operators (and all S2R eco-system service providers), with planning, monitoring and reporting capabilities from data collection, filtering, and analysis to build end-user travel and transport intelligence.	Rail & Transport Service Provider decision tools, open channels monitoring (web, press, forum, blog, tweets, ...), demand/supply/planning/forecast, customer experience improvement, fidelisation and revenues assurance by consumer/business	Travel and Transport Intelligence

#### **4.5.6.2. Technical ambition of the Business Analytics Demonstrator**

##### **State of the art:**

Business Analytics might not be a household term yet, but it's certainly gained adhesion in the business community. With more and more companies understanding the importance of data, business analytics tools are spreading from mass enterprises and tech-oriented companies to small and medium companies in a much wider range of industries, including the rail sector.

The term Big Data is somewhat ambiguous, but there can be no doubt that the amount of data is growing exponentially, and that it is becoming more complex to handle in the process. With storage prices dropping and automated extraction methods becoming more sophisticated, companies are finding themselves collecting massive amounts of data. Much of this data is unstructured and collected in tables which vary wildly in format and size.



This tendency of data to grow in size and complexity is expected to increase as the use of publicly available data sets becomes more extensive. Yet more data is being generated by the Internet of Things, a number which is also expected to see significant growth in coming years.

The business world is only beginning to harness the power of external data sources and learning how to gain actionable insights from them; but as knowledge in this area grows, analyzing the data found in these huge repositories is expected to become an integral part of Business Analytics.

The real disruptive opportunity is to create value through refining data into information. Starting from unstructured raw data, enriched by meta-data describing the context, fusion generates synthesised data which provides situational awareness, typically driving threshold based events. Predictions and forecasts extrapolate from the data based on fixed models, which are themselves configured with meta-data: this ranges from simple predictions through sophisticated, wide-area optimisation of scenarios based on alternative of cost functions. Finally, big analytics use machine learning techniques to identify trends and patterns of behaviour that are unexpected, drawing operators' attention. Visual analytics uses novel visualisation techniques to show specific trends or as an alternative way to help people spot discontinuities in data.

There are three aspects that the Business Analytics (or Intelligence) must consider:

- **Managerial/Process:** focus on the process of gathering data from internal and external sources and of analysing them in order to generate relevant information for improved decision making.
- **Technological:** focus on the tools and technologies that allow the recording, recovery, manipulation and analysis of information.
- **Product:** describe Business Analytics as the emerging result/product of in-depth analysis of detailed business data as well as analysis practices using Business Analytics tools.

A lot of research and developments have been made on the first two aspects in the last years, and industrial developments exist already adapted to various markets. Concerning the technological aspect, we can refer to the Cubist EU project (FP7-ICT 257403) which is looking at applying the semantic approach (as developed in TD4.1) to Business Analytics.

### **Ambition of the TDs**

For what IP4 is concerned, the general ambition of Business Analytics (TD4.6) is to propose a general platform and a set of tools allowing a better analysis of the passengers flow in the network, in order to improve the operations with adapted transport means, or with adapted offers (tickets less expensive at some hours, coupling of transport tickets with specific event, etc...).

Data Warehouse, Customer Database and single mode business optimisation strategies and tools exist today only internally to single Transport Operators (Rail or Public Transport), making not possible a multimodal, door-to-door trans-European Green Mobility Intelligence.

Furthermore, some recent and powerful tools like Big&Open Data capability by remote sensing and massive data analysis and Real Time Traffic information are not yet exploited, and are not correlated and transformed into usable Travel Knowledge for Context Aware proactive suggestions to Travelers, Shipping Enterprises & Transport Operators.



Critical Operator Infrastructure Data Security and Travelers Information Privacy are not often guaranteed, and it is not possible to propose and deliver seamless travels, as all partners work on different datasets.

### **Business Analytics objectives**

The objective is to develop a demonstration with the following objectives:

- Provide to all Shift2Rail transport product/service providers a common business intelligence foundation to monitor IP4 target strategic indicators, structured in execution / operational KPIs, and to manage service lifecycle for continuous improvement of rail-centric travel experience of European travellers.
- Enable decision tools for rail and multi-transport operators (and all S2R eco-system service providers), with planning, monitoring and reporting capabilities from data collection, filtering, and analysis to build end-user travel and transport intelligence.
- Synthesize Big Data in Travel-Transport Analytics over multisource channels for Rail Business Executive (Sales, Marketing, Customer Service) and Mobility & Traffic Management Control Rooms (Operation support for passengers mobility and freight logistics).
- Collect historical business data (within IP4, from Ticketing) and travellers behaviour on all channels (mobile, social, web, ...) (within IP4, from Travel Shopping, Companion, Tracker, ...) to allow clearing-house among operators, as well as dynamic personalized service in real time (in memory-computing).

By correlating all information and knowledge extracted from travellers/customers records and travel behavior, then filtered as operator suggestions, the Business Analytics framework and its applications will enable new services for the different stakeholders:

The traveller:

- Can easily be advised with Travel suggestions by proximity services (gates, mass transit, rail, buses, ...);
- Can benefit from joint entitlements (Smart Ticketing across Public Transport, Parking, bike sharing, car sharing, museums, hotels, etc.);
- Can be safely driven over multimodal travels and pathways (bus, train, ferry, mass transit, ...);
- Can access with smart devices any mobility information and service (vehicle localisation, traffic information, alternative routes, booking, ticketing, e-payment, etc.);
- Will be progressively engaged to rail & green mobility by Social Networking within a S2R Travel Community (train lovers, car sharing, bike sharing, van sharing, ...), becoming a prosumer (short for “producer/professional & consumer”, or proactive user that autonomously contribute to service improvement and its diffusion), and so a S2R promoter himself.



Any Transport Operator in the scheme can easily:

- Know all Historical Travel/Shipment Operation Data about traffic data, passengers volume, seasonal data, ...;
- Plan, Simulate & Forecast peak and events
- Interconnect its systems to allow multi-operator settlement and clearing house invoicing/balancing;
- Analyze and Control Operations via Transport Dashboarding tools for CRM, Sales/Marketing;
- Combine Transport Analytics for single-segment or multi-segment and multi-modal traffic data for end-to-end service performance optimisation (regional-urban mobility systems);
- Transmit dynamic Traffic/Travel Information (timetable schedule with expected arrival, alternative routes options, jam/crowd/crisis notification, ...).

#### ***4.5.6.3. Specific Demonstration activities and contribution to ITDs/SPDs***

The Business Analytics Platform will be defined in order to leverage structured, unstructured and streaming data to obtain valuable, actionable insights that allows travel operators, travellers, Joint Undertaking members and all Shift2Rail Ecosystem product/service Providers to make better decisions and focus on their needs for creating value from data.

Rail and Transport Big Data analytics is fundamental to help Travel Operators understand exactly which Traveller/Customers are unhappy with service and what caused the dissatisfaction, and predict traveller behaviour. To obtain this information, a lot of unstructured, social and mobile data, needs to be processed (loosely-structured bytes of data in different locations).

The general process applying to TD4.6 “Business Analytics” is to develop use cases showing how information coming from the different TDs can contribute to a better fit between supply and demand. At the most advanced maturity level, the demonstration will involve multiple service providers from different modes showing a combined multi-modal set of indicators.

The demonstration scenario will take the form of specific developments for the different system releases (see below). For each of the system release, and depending of the implemented functions at TD levels, and subsequently of the set of data available, a systematic overview of potential indicators will be discussed with operators and infrastructure managers, a list will be agreed and the implementation will be performed. Even if TD4.6 is less tightly coupled than the others TDs, the developments will be as much as possible aligned with the ITD7 releases.

#### ***4.5.6.4. Impact of the Business Analytics Demonstrator***

- On the customer experience and the travellers-operators relationship.

By allowing passenger feedback to be taken into account, the business analytics platform will place the traveller at the centre of the transportation eco-system. Being proactive, the traveller perceived influence on the eco-system will foster a change of attitude toward the transport services. In the



same way the business analytics platform will initiate a first answer to the complex environment of public relationship for the public transport operators. Although public transport operators have Customer Relationship Management (CRM) that allow them to define their commercial policies, the social network capable intelligent tools provided by the business analytics platform will allow the transport operators to leverage the social network capacity to involve their customers and build a smarter customer relationship.

- On the economics of the transportation ecosystem.

By providing a detailed and unprecedented understanding of the complex dependencies within the fragmented transportation ecosystem, the business analytics platform will allow public transport operators to better allocate their funds (on more precise items or on more efficient investments) resulting in lowering the costs of operations and increasing service availability. This will reinforce the capacity to anticipate potential crisis and better prepare events (that temporarily increase the demand for mobility on a large scale) thanks to the business analytics tools (including predictive and prescriptive analysis) involved in planning and resource allocation.

- On the access to top-talent skilled resources

The business analytics technologies join together many complex technologies and IT services which are now being extensively developed in academic environments as an area of excellence and future major economic growth. The natural association of transportation ecosystem with business analytics in order to work with the very large amount of data produced by the systems across Europe will generate demand for innovative technology solutions and turn the Rail Travel Industry into an attractor of top talents, which in turn can contribute to its self-sustained ever-greening. Creating intelligent mobility services and the ICT applications to support them will become at least as gratifying as working in advanced 'pure-internet' services.

#### **Strategic impact:**

Exploitation Strategy is for assuring interests of the Rail/Public Transport industry, stakeholders and European travelers, as base for potential market uptake beyond the project itself.

Opportunities and barriers results from Business Analytics will be analyzed as impacts for the whole IP4 project, in a go to market approach that will lead all partners to a successful exploitation process, clearly addressing purpose, audience, message and method.

Promoting rail-centric urban mobility in regions and cities involve many different actors, such as key stakeholders:

Rail Operator – long distance operators by rail;

- Urban, suburban and regional public transport: Rail; Metro; Tramway; Bus; Waterborne.

Shift2Rail Product/Service Providers:

- For instance mobility service providers such as car sharing or carpooling operators;

Traveller/ Transport Enterprises and Customers

- All transport users and citizens, including public transport customers, car drivers, cyclists and pedestrians;

Authorities:

- Joint Undertaking Members; European Commission; Road and rail authorities; Committee of Regions; Local/regional/national authorities that supervise transport services and urban traffic.

Business Analytics platform services could offer information needed by emerging Business models, clearly moving from implementation by public authorities to partnerships sought with the private sector and the involvement of service users, taking the most benefit of each group of actors: Public transport stakeholders; Private transport stakeholders; Travel and transport high technological services/product providers; Travelers, who assess the travel services.

#### **4.5.6.5. Implementation of the work programme**

The Interoperable Framework demonstrator handles all interoperability tasks and is therefore the mediator of all interactions across Technical Demonstrators within IP4 and across data assets provided by multiple organisations. As a complex technical foundation for all technical demonstrators, it is important that the strategy for its development be provided with 'built-in' capabilities accommodated to minimize risks to the successful completion of the entire IP4 programme, and for it to be coherent with the mechanisms proposed in ITD7 to guarantee overall integration of the IP4 products.

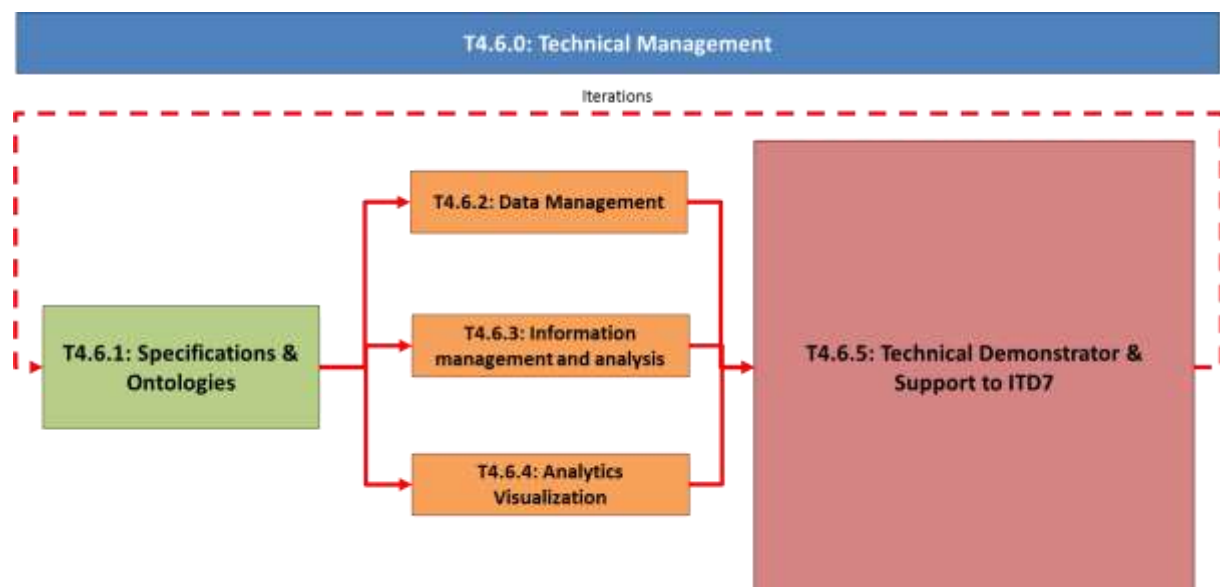

### **TD6 task structure**

#### **T4.6.1: Ontologies & Specifications**

This collaborative task will focus on the exhaustive definition of a vocabulary of semantic terms (ontology) applicable to the Business Analytics domain for all considered transport modes. This will



result in a formal description and abstraction of key objects, data, interfaces roles and concepts shared by the business analytic functions. Formal ontology description will take into account the TD1 Interoperability Framework recommendations and tooling environment.

Involved partners will produce open specifications for a Business Analytics technical enabler allowing multiple and concurrent implementation of related services. The open specifications will consider the possible architectures for Business Analytics Implementation, and the interfaces for the exchanges of relevant data between services and modes.

#### **T4.6.2: Data Management**

This collaborative task will focus on producing software components that, within a multimodal ecosystem, integrate multiple data source (from multiple actors) to feed the Business Analytic platforms.

This activity includes the definition and implementation of the Internal Data Model, the identification of IP4 potential data source and implementation of connectors to collect and integrate data from IP4 sources (TDs) through the usage of the Interoperability Framework (TD4.1), the identification of potential external data source and implementation of connectors to collect and integrate data from external and Internet (big) data sources, and the implementation of connectors to travellers data source such as the travellers 'feedback, social networks, other unstructured or semi-structured data feeders.

#### **T4.6.3: Descriptive and predictive Analytics**

Within this collaborative task, the contributors will produce software components that rely on previously defined data source and perform business intelligence and business analytic processing to generate insights of the ecosystem. The business analytics components will include the aggregation of the identified data into relevant KPI, forensic and data mining components to support the analysis of the past events, near-real-time analytics to provide the users with accurate representation of what is actually happening in the eco-system. Information from traveller and social media will also be considered.

Design of predictive models by analyzing all available information in business analytics system in order to propose patterns of correlation between dependent variables to better understand the business and deliver better results. Application of a range of different techniques, such as: descriptive and predictive analysis, simulations, expert systems, optimisation, forecasting, real time analytics, text mining, natural language processing, etc.

#### **T4.6.4: Analytic Visualisation**

This collaborative task aims to present visually the process data once data collection and analysis have been completed. As such, software components will be produced to display business analytic results to a wide variety of data consumers. The first data consumer is the transport operator itself. This task is offering the transport operator an intelligent platform dedicated to their concerns. This Service Operator Intelligent Platform is presenting an access to the above mentioned business analytics results to IP4 service operator such as (but not limited to) Public Transport Operators, Public Transport Authorities, Retailers. Other target audience/data consumers considered include



Social CRM to monitor and manage the relationship with the traveller through social networks and the traveller as information consumer. Developments in Business Data Representation include Query & Reporting solutions, Data Discovery, OLAP, Dashboards, Balance Scorecard and Geospatial, for consumption in traditional formats and through mobile devices that allow for the inclusion of the geographical and time context.

#### **T4.6.5: Technical Demonstrator & Support to ITD7**

This collaborative task allows the integration of all implemented software components and functions for Business Analytics across all modes. It will ensure convergence of internal and external interfaces, performances and functionalities. It will result in the production and presentation of a complete Business Analytics Technical Demonstrator.

This integration will be monitored by ITD7, in charge of the system level release, integrating all inputs from the different TDs.

#### **4.5.6.6. Planning and budget**

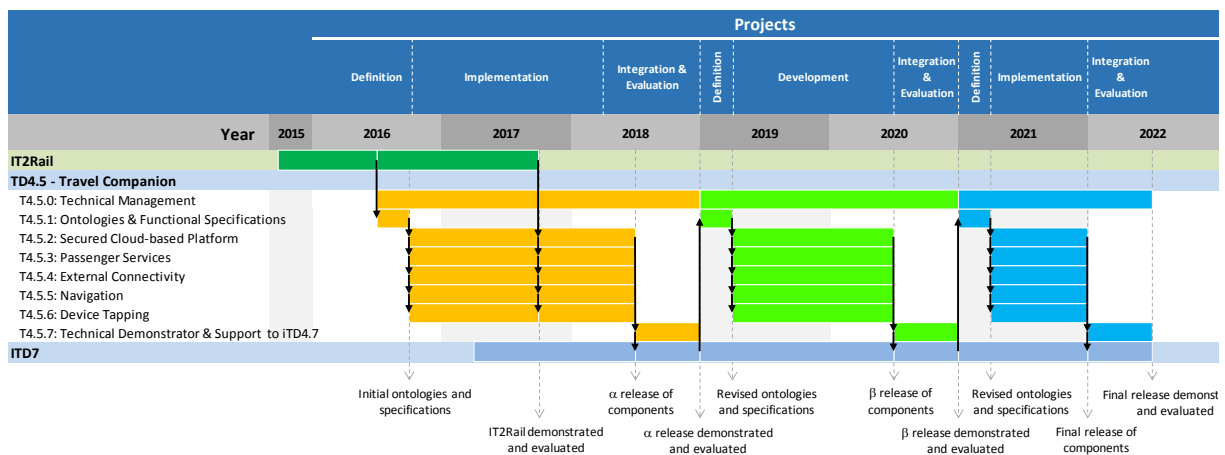

The estimated total budget for TD4.6 is around 9.9M€.

#### **4.5.7. ITD4.7: Overall IP4 Coordination and demonstration**

##### **4.5.7.1. Concept and objectives of the ITD7**

The attractiveness of the European Railway lies fundamentally in its capabilities to contribute to the social infrastructure by providing smart and green travel services as a mean to engage in commercial, cooperative and leisure activities. Whilst IP4 aims to address the ever growing need of connectivity through several technical demonstrators encompassing all IP4 research areas, the Integrated ITD4.7 will ensure overall engineering coordination across all contributors and stakeholders to transform the Travel experience in a complete integrated and seamless product.



This integrated technical demonstrator spans across all research areas of IP4 to promote a global and common approach allowing all IP4 Technical Demonstrators to meet the objectives of the Shift2Rail master plan. As such ITD4.7 will promote a collaborative approach with all IP4 participants and will define processes for decisions mechanisms, the objectives being:

- *Support Technical coordination:* IP4 will gather contributors from a large spectrum of the IT and transportation market, including industries, operators, IT providers, etc.
- *Federate a community around the innovation concepts of IP4:* a key objective is to ensure the appropriate dissemination of key concepts, progress and communication strategy within Shift2Rail community and toward the global ecosystem and future users of IP4. Participant of the IP4 TDs will therefore play the role of the IP4 ambassador toward the EC organisation and any other key stakeholder's communities such as TAP-TSI, Full Service Model (FSM), Smart Ticketing Alliance (STA) and any other connected initiatives.
- *Ensure Engineering Consistency throughout IP4 Technical demonstrators:* Consistent Specifications and design architectures (functional, logical, applicative, technical) are key to ensure that the global concepts and principles of IP4 are cascaded throughout the TDs and subsequent tasks and modules, thus eradicating holes or overlaps in the design. The objective will be to ensure that common language, methodology, regulations, concepts, templates, tools etc. are disseminated throughout the TDs and share by all participants.
- *Promote convergence of all IP4 technical demonstrators:* IP4 will aim, not only to specify core functions for a new transportation ecosystem, but also to create a complete technical enabler encompassing the innovations of each TD in references implementations. As such, convergence of integration, testing and verification activities will allow to build a fully functional demonstrator with the objective to reach a global Technical Readiness Level (TRL) for the IP4 solutions compatible with mid-term market uptake.

At the core of ITD4.7, lies the objective of openness of the transportation ecosystem to new business actors, able to rejuvenate the transportation ecosystem technologies and business models, thus achieving the goals of European leadership in the market. ITD4.7 is the guarantor of the openness of new solutions and architecture specifications, allowing new entrants to benefit from enabling technologies and exhaustive specifications.

#### **ITD7 releases:**

As explained already in the general IP4 description, ITD7 will release, on a regular basis and for all TDs, successive versions of enriched deliverables, from early conceptual prototypes to the final version.

Such methodology provides a perfect framework as well as methods and tools to develop modern highly interactive IT systems while lowering the risk of technical failure and controlling costs and time frames of such developments and maximising:

- The capacity of the system to satisfy real requirements of users,
- The software reliability and performance guaranteed in critical conditions,



- The flexibility and reactivity of development tasks.

For that purpose, the iterative process offers:

- An effective software life-cycle (timing different from the traditional V cycle) using rapid prototyping methods from early stages of the project,
- A modular software architecture,
- A continuous integration and test strategy,
- A detailed phase-by-phase description of objectives, KPIs, targeted features, involved persons, and evaluation framework.

Modern prototyping, rapid application development methodologies as well as agile software development approaches will be considered to define the appropriate methodology.

The initial phase of each release includes:

- Evaluation results of the previous iteration, if any;
- The identification, definition, or refinement of the requirements, if needed supported by the presentation of early prototypes, use cases, functional specifications, ontologies, overall architecture, interfaces and standards, as well as evaluation plans;
- The analysis of the state-of-the-art as well as best practices and lessons learnt in other relevant initiatives or other domains.

The results of this first definition phase will be used and as input to define or refine the technical specifications and technological choices, design and implement the current release.

Continuous integration and testing methods will be proposed in order to enable the regular delivery of intermediate versions. Only major ones will undergo the last phase.

#### **4.5.7.2. Impact of the IP4 – ITD7**

The integrated ITD 4.7 is significantly different from the other TDs as it will not provide ground-breaking technologies or concepts, but will orchestrate the implementation in a consistent, coherent and transparent manner, and will deliver an overall demonstrator that satisfies the IP4 community and meet the Shift2Rail Master Plan objectives.

The ambition of ITD4.7 is to foster an unprecedented coordinated effort in the deployment of innovation IT solutions for the transportation ecosystem. To bring together through a global technical framework multimodal travel services (such as Travel Shopping, Booking & Ticketing, Trip Tracking) at the European scale, and to integrate those in a “unique ID” Travel Companion providing end-to-end, multimodal, seamless capabilities for travelers, is in itself an immense breakthrough compared to the current state of the art of scattered and limited services available today.



Finally the integrated TD4.7 will aim to mandate the openness of specifications and architecture proposed by each Technical Demonstrator in order to allow the market forces to join with IP4 concepts in the most efficient manner, thus accelerating the transition to operational systems.

**Expected impacts:**

- Impact 1: On the community adoption of IP4 concepts:

Although it is difficult to measure the level of adoption of the IP4 framework in the community, due to the complexity and scale of the market, ITD4.7 will allow a more effective transition of the transportation ecosystem to IP4 disruptive and innovative technological concepts. By including a wide base of stakeholders in the consistency works, principles will be shared and accepted in much more effective manner. As ITD4.7 will be a guarantor of the production of open specification throughout the TDs of IP4, a good indicator of the openness of the specification produced will be in the speed of adoption by the market. Moreover, the dissemination of the overall approach towards the transport community will be monitored by ITD7.

- Impact 2: On the consistency of engineering approach & deliverables:

ITD4.7 will allow a common approach to the description and implementation of overall IP4 open specifications, conceptual architecture by each Technical demonstrator. This will result in a more effective, globalised engineering approach and consequently on the production of deliverables more widely recognised and accepted by stakeholders. An indicator of this impact could be performed through the percentages of acceptance of Standards and Open Specifications by Stakeholders and through standard engineering progress indicators (requirements, stability, etc.)

- Impact 3: On the convergence of a global IP4 technical demonstrator:

To demonstrate the satisfaction of the objective for an overall IP4 demonstrator integrated, verified and validated, some indicators could be put in place such as: standard integration progress indicators (percentage of modules integrated, defects and change management, etc.), standard verification progress indicator (percentage of requirements tested, defects and change management, etc.), standard validation progress indicator (percentage of use cases demonstrated, percentage of functions accepted, percentage of acceptance by Stakeholders and Business Requirements and Implementation Group).

#### ***4.5.7.3. Implementation of the IP4 – ITD7***

##### **T4.7.1: Integrated Technical Coordination**

This collaborative task will focus on the effective technical coordination of the IP4. It will ensure the progress of the various TDs to a technical readiness level compatible with the objectives of the global IP4 demonstrator. Technical Quality Assurance will be ensured through defined quality procedures including unambiguous TDs deliverable contents and levels. Planning of activities will focus on the formal scheduling of activities in accordance with the action plans and internal milestones. All technical coordination principles will be describe in a Technical Principles document which will be maintained along with a set of technical management documents (Technical master schedule,



Technical Quality Plan, Technical Management Principles etc.) provided to all IP4 members and used by the Technical Management Committee to monitor and control the overall progress.

#### **T4.7.2: Integrated Community Management**

This collaborative task will focus on the establishment of a strong and vibrant IP4 community, promoting the innovative concepts and disruption potential to all stakeholders of the ecosystem, within Shift2Rail and to external parties. Studies and white papers will be produced to provide some valuable and beneficial insights on topics related to the concepts being brought forward and to support the technical decision process. This activity will also ensure cohesion and appropriate communication between all the participants of IP4.

#### **T4.7.3: Integrated Engineering Consistency Management**

This collaborative task will initially focus on the establishment of Engineering methodology & guidelines and promote the application of a robust engineering system methodology. This will ensure the project is structured around a technical, according to the best industrial practices. A Glossary will be created to formalise the technical and business environment through a comprehensive list of fundamental terms, acronyms and concepts, at a system level. Its aim is to eradicate any ambiguity that could affect effective communication of the project's stakeholders and convergence. TDs ontologies will be part of the inputs for this glossary. Top level requirements baseline that will be applicable to all TDs will be identified by the contributors of this task which will provides an overall technical project view and functional architecture to all stakeholders. Finally, as the works progress on each TDs, an dedicated interfaces consistency activity will be the guarantor of the overall consistency of concepts application, of the interoperability and openness of the design.

#### **T4.7.4: Integrated Technical Demonstrators Convergence Management**

This collaborative task will consolidate, through cross-functional reviews, the project overall convergence between all TDs deliverable specifications vs. the TD4.7s technical assumptions (requirement, glossary...). As the TDs modules become more mature and the TD demonstrator can be reviewed, tested and adjuster, the contributors to this task will organise the iterative integration and verification activities. To this end a lead contributor will coordinate the deployment in an integrated manner of the software components of each TDs and their testing a complete and realistic door-to-door interoperable and intermodal use case basis on the TD4.7 verification & testing platform. Accordingly, this task will setup the overall IP4 Testing & Verification platform where the demonstrators will be assembled and integrated with each other's to provide the overall vision of the IP4 technical enabler. This will include activities of configuration control and versioning of all components deployed.

The releases of ITD7 will propose incremental functional scopes and are quickly exposed below:

- **IT2RAIL release (Oct 2017):** will focus first on the co-modal journey with a limited number of modes (rail, air, coach and urban), and demonstrated through a limited number of use-cases. The functions developed within IT2Rail Work Packages (the topics of which correspond to the Technical Demonstrators of IP4) are either generic or needed for the use cases.



- WP1 & WP6: low degree of automation of discoveries, limited number of resolvers, business analytics limited to traveller information,
- WP2 & WP3: light post sales, simplest reaccomodation (full trip),
  - Context hardly realistic (for the undo)
  - Multiple tickets, no single contract, no real payment (no bank)
- WP4: information disruption (without consistency check), calculation of the itineraries, no check of the entitlement
- WP5: Preferences, one profile, simplest PRM and carbon footprint, security not completely addressed, no combination between indoor and outdoor navigation
- **Alpha realase for IP4 (Dec 2018):** co-modal with all identified modes, addressing more use-cases
  - TD4.1 & TD4.6: As the initiative evolves and extended functionalities, new approaches, and new transport modes are included on it in the new releases of the several TDs, technological Framework developments will be extended to support the new functionalities required and the new information and services included. It should improve its performance through new tools, resolvers and higher automation of processes. Business analytics will also include operational information at this stage.
  - TD4.2 & TD4.3: post sales, reaccomodation (partial trip),
    - Context more realistic (for the undo)
    - Multiple tickets, no single contract, co-modal settlement, ...
  - TD4.4: information disruption (with consistency check), calculation of alternatives for itineraries and legs
  - TD4.5: preferences with different profiles, more security (differences between privacy and financial aspects in TD4.5 & TD4.3), navigation with combination between indoor and outdoor, interaction between travel companion and information in the station, increasing the number of services, including some adaptation for people with special needs (old people, vision, etc.)
    - A first version of the cloud-based platform supporting the S2R Traveller experience, including the traveller's virtual space as well as the required processes to dynamically profile the users and orchestrate their experience;
    - Prototypes of the traveller companion concept featuring a homogenous multi-device interface, exploiting all available devices, to offer an intuitive door-to-door experience;
    - Prototypes demonstrating novel interfaces (Augmented Reality, indoor positioning...) and 3D geospatial technologies to power a S2R traveller Experience and enable novel navigation assistance concept;



- Delivery of a first prototype of the tools enabling the rapid creation, simulation, evaluation, and ubiquitous experiencing of such services
- **Beta Release (Oct 2020):** towards intermodal ticketing.
  - TD4.1 & TD4.6: Functionalities of the releases will be incremental, supporting in each release the new functionalities and needs of the other TDs that use the Interoperability Framework to fulfill their activities. In this release it is expected more automation of processes, more resolvers, business analytics with operational information in nearly/real time
  - TD4.2 & TD4.3: Inter-modal:
    - TD4.2: intermodal pricing and intermodal availability
    - post sales, reaccomodation (partial trip),
    - Context more realistic (for the undo)
    - Real payment, single ticket, single contract, ...
    - Proposed standard for integrated ticketing across modes
    - Intermodal settlement
  - TD4.4: check of entitlement using TD4.3, information disruption including other relevant sources, e.g. social media, weather conditions
  - TD4.5: preferences: dynamic profiling, more categories (attributes), security completely covered, augmented reality combined with other methods of navigation
- Release 3 (mid 2022):
  - Everything together and Synchronized, with maturity greater than TRL6

The estimated total budget for TD4.7 is around 7.7M€.

## 5. IP5 – Technologies for sustainable and attractive European rail freight

### 5.1. Context and motivation

Although rail freight markets within the EU have been open for a number of years, the modal share of intra-EU rail freight transport has slightly declined in the past decade so that the sector risks failing to fulfil the ambitious objectives that were set in the Transport White Paper in terms of developing rail freight, namely: to almost double the use of rail freight compared to 2005 and to achieve a shift of 30% of road freight over 300 km to modes such as rail or waterborne transport by 2030, and of more than 50% by 2050.



The industry's stagnation can partly be explained by the existence of legal barriers restricting competition (including the infrastructure access regime, taxation, etc.), but also by problems of operational and technical nature, which impact the overall capacity and performance of the sector.

Today's main limiting factors are:

- problems with handling freight trains on mixed traffic lines during peak passenger trains hours
- insufficient ability to effectively deal with incidents
- long- and unreliable lead-time in terminals, hubs and marshalling yards accompanied with high operational costs
- low reliability and high operational cost due to manual handling processes and resource planning based on experience or stand-alone IT systems
- reduced profitability, competitiveness and investment capabilities of railway undertakings/infrastructure managers and railway service providers due to the increase of operational costs and of LCC for Assets and infrastructure
- limited train weight, length and speed due to limits in the strength of standard couplers and propulsion concepts of locomotives
- low performance and flexibility in serving the last mile in single wagon load
- poor payload-deadweight ratios, especially in the market most emerging segments of containerized single goods transports.
- reduced acceptance of rail as an environmental friendly transport mode due to noise and vibration of freight trains/wagon
- missing electrification of freight wagons to benefit from intelligent sensors and communication systems
- bad or no visibility of goods towards shippers and end-customers due to not integrated data processing along the supply chain

The members participating in IP 5 are convinced that a significant share of the issues mentioned above is due to:

- insufficient optimisation of infrastructure and rolling stock capacity
- the low level of automation of the operational processes
- limitations in wagon and locomotive technology
- lack of communication, data management, data exchange, integrated IT systems/platforms
- lack of TAF TSI implementation, which prescribes standardized data exchange platform between stakeholders





The cost competitiveness and the reliability of freight services need to be considerably improved so that rail freight can be in a position to offer a cost-effective, attractive service to shippers that helps to take freight away from the already-congested road network.

The challenge is two-fold:

- To acquire a new service-oriented profile for rail freight services based on excellence in on time delivery at competitive costs, interweaving its operations with other transport modes, addressing the needs of the clientele among others by incorporating innovative value-added services.
- To increase productivity, by addressing current operational and system weaknesses and limitations, including interoperability issues, and finding cost-effective solutions to these problems, including optimisation of existing infrastructure and fostering technology transfer from other sectors into rail freight.

For European rail freight to become more attractive, the rail freight sector must provide customer tailored services to its clients and be more effectively integrated in the logistics value chain. Reliability, lead times, deliveries on-time and in full, frequencies and cost must meet customer requirements for different goods segments. Investments in rail innovations should be compatible with anticipated future needs and changes brought about by macro level trends in trade and production patterns, goods types, shipment sizes and consumer behaviour.

The rail freight sector must also take advantage and integrate new developments that are impacting other parts of the logistics chain, in particular digitalisation, which can help to drastically reduce LCC and operation costs, as well as novel processes and technologies such as 3D printers or FAB-LAB capacities.

Action in the rail freight sector is urgent as it risks losing its position as the most environmentally friendly transport mode due to innovations in other transport modes and must come up with an answer to new challenging developments in the road freight traffic segment, such as the implementation of autonomous driving modes.

## **5.2. Objectives of the IP and expected results**

To tackle this broad spectrum of challenges, IP5 has to follow a holistic system approach where the different components interplay in an optimal way to ensure value creation for customers, the rail operating community and society.

The innovations and enabling technologies stemming from the TDs in IP 5 must be regarded as milestones on a trajectory towards a long term vision of a high performing, 24/7 operating, automated/autonomous railway that optimises infrastructure capacity, is integrated with other transport modes through fluid and seamless terminal operations, and is sensitive to changing customer demands. When incidents occur, customers are informed about alternatives and routes that meet their specific requirements and are rebooked and rerouted in some cases without feeling the effects of the incident. The railway of the future fully exploits the potential of digitalisation to increase its attractiveness and viability. S2R will also be instrumental for the continuous development



of rail freight's green credentials in door to door mobility solutions, which is a necessity as the alternative modes are improving their environmental performance.

IP 5 is the first step towards the long term vision and it will focus on a number of specific work areas with a view to boosting the performance of rail freight.

In particular, the huge potential offered by digitalisation, built on the TAF TSI, will boost rail freight productivity and punctuality, creating competitive cost structures and stimulating growth in Europe by providing more efficient, reliable and high-quality rail freight services.

The development of technologies that enable a higher degree of automation and autonomous operations will raise productivity, reliability and reduce cost dramatically.

Automation in train composition and operation will raise the quality of rail freight services, improve staff productivity and resource utilisation and increase infrastructure capacity. Pan-European rail freight is a key enabler for automated driving systems.

Customers and lifecycle-costs will benefit from predictive maintenance and smart, self-monitoring freight assets. The fusion of sensor data with pattern recognition methods will ensure cost-efficient asset management in both operations and maintenance.

Driver assistance, component optimisation and advanced propulsion technologies will significantly reduce energy consumption and emissions, strengthening competitiveness while lowering the carbon footprint.

Increased flexibility through virtual train coupling and the resulting increase in freight train lengths will help to respond to the challenge of road freight productivity and enable sustainable growth in freight traffic along core European corridors.

All work developed in respective TDs has to take into account the present and coming (2020) TAF/TSI standards for each relevant objective/topic and the TAF TSI Strategic European Deployment Plan. Furthermore the current processes regards to TAF/TSI must be followed by each TD in relevant issues.

The following table summarises the main objectives of IP5 and provides an overview of some of the concrete deliverables that can be expected to result from the activities undertaken in the IP.

**Table 21: Objectives and challenges of IP5**

Objective	Result	Practical (concrete) Deliverable
Capacity increase	<i>Wagons with optimised payload, maintainability, lower noise and track attrition. Flexible, faster train compositions. Greener traction and greener last mile capabilities.</i>	<ul style="list-style-type: none"> <li>Wagon electrification</li> <li>Modern braking</li> <li>Efficient propulsion</li> <li>Sensors, monitoring analysis</li> <li>Efficient terminal handling</li> <li>IT systems</li> <li>Operating performance facilitating blending</li> <li>In train communication</li> <li>Efficient coupling</li> </ul>
	Better control on the wagons, the train and its actual performance	<ul style="list-style-type: none"> <li>Distributed braking enabling better performance</li> <li>Modern wagon design</li> <li>Communication in-train and to the outside</li> </ul>
Operational reliability increase	Modern and reliable technologies and components	<ul style="list-style-type: none"> <li>Fail resistant design with sensors and technology providing continuous monitoring, information analysis</li> <li>Developed propulsion</li> </ul>
	Smart operation and on-line information systems	<ul style="list-style-type: none"> <li>Combination of border crossing train path allocation and slot planning</li> <li>Consideration of real time data</li> <li>Collection and processing of combinations of different transport chains for individual transport units</li> <li>Improvement of the interoperability and safety</li> <li>Promotion of market opening</li> <li>Improvement of performance of rail freight</li> <li>Creation of incentives for product innovation and service quality networks</li> <li>Terminal handling and procedures</li> </ul>
	Few unexpected occupancies	Monitoring of disturbances
	Early corrective actions enabled	Intelligent data analysis
Railway system life cycle cost reduction	Faster Return of Investment (ROI) of the vehicles	<ul style="list-style-type: none"> <li>New vehicle with high productivity and high yearly mileage.</li> <li>Less downtime for vehicles.</li> <li>Less need for spare parts and vehicles.</li> </ul>
	Reduction in the needed number of vehicles for a given capacity	Vehicles with increased productivity and availability will produce more and have less down-time.

Objective	Result	Practical (concrete) Deliverable
	Reduction in the cost of vehicle maintenance	Modern and reliable system architectures and component technologies Better and more standardised on-line monitoring of actual condition
	Reduced wear and tear of the infrastructure	Track friendly vehicles with better running properties. Smoother running
	Reduction of damage of the infrastructure	Sensors noting abnormal circumstances
	Reduction in the energy consumption	As defined below
Energy Efficiency	Reduction in the mass of the wagons	Modern modular wagon design Distributed braking allowing for reduced tare weight Monitoring of the running properties
	Reduction of energy losses	Better and more adapted braking
Noise reduction	Modern wagon design	Less noise from wagons
	Noise reduction oriented design of brakes	New braking systems
	Smoother operation	

### 5.3. Past and ongoing European & national research projects

The members plan to use input from other EU projects that have been developed in the field of freight, such as MARATHON, SPECTRUM, TIGER, E-FREIGHT, and D-RAIL etc. Furthermore, they will seek links to the CAPACITY4RAIL project and to the project SMARTRAIL.

### 5.4. Set-up and structure of IP5

#### 5.4.1. Structure

The IP is structured in seven TDs with the ambition to deliver demonstrations at TRL 6-7. The main red thread is a more intelligent equipment and automated processes and operations, with digitalisation as an enabler.

The seven TDs are axed around the three following work streams:

- Optimisation of operational processes for infrastructure, operations and assets
- Automation of rail freight system
- New markets



Each TD is composed of different focus areas. The focus area is the framework and level of detail, where the project work is described and the activities of all involved parties are bundled.

Research and Innovation Area	Proposed Technology Demonstrator	Focus Area
<b>Implementation Strategies and Business Analytics</b>	T.D. 5.0 – Implementation Strategies and Business Analytics	Identification of market segments Development of KPI's Migration Plan
<b>Freight Electrification, Brake and Telematics</b>	T.D. 5.1 – Freight Electrification, Brake and Telematics	Condition-based maintenance Automatic Coupling Telematics and electrification
<b>Access and Operation</b>	T.D. 5.2 – Access & Operations	Improved methods for time table planning Real-time yard management Real-time network management Increasing speed for freight trains
<b>Wagon design</b>	T.D. 5.3 – Wagon Design	Low-noise, lightweight, high speed & track friendly running gear Core market wagon 2020 New market wagon 2020
<b>Novel Terminal, Hubs, Marshalling yards, Sidings</b>	T.D. 5.4 – Novel Terminal, Hubs, Marshalling yards, Sidings	Intelligent video gate terminal with new design Hybridisation of legacy shunting Fleet
<b>New Freight Propulsion Concepts</b>	T.D. 5.5 – New Freight Propulsion Concepts	Freight Loco of the future Last mile propulsion system Long Trains up to 1500 m Driver Advisory System
<b>Sustainable rail transport of dangerous goods</b>	This area is mainly handled in 5.1 and 5.3	
<b>Long-term vision for an autonomous rail freight system</b>	This area is mainly handled in 5.6 .	Autonomous Train Operation (ATO)

#### 5.4.2. Involvement of Members in activities

Participating members are the operating community, technology suppliers and research providers. Open Calls will be used for involvement of outside partners to complement the competencies of the IP 5 members.



## 5.5. The Technical Demonstrators of IP5

### 5.5.1. TD 5.0 – Business analytics and implementation strategies

#### 5.5.1.1. Concept and objectives of TD5.0

##### Context

While the past decades have seen substantial improvements in passenger transport (e.g. high speed trains and infrastructure), rail freight is lagging behind and rail freight companies struggle to compete with the performance levels that can be achieved in road transport. In addition, noise emissions by freight trains are an obstacle to shifting freight from road to rail [COWI 2013]. Thus, the railways lost continuously market share in the freight transport business in the past decades and there can hardly be expected that this process will turn in the future unless the root causes can be addressed and eliminated effectively. Road freight traffic is expected to implement autonomous driving mode in the next decade, which will further improve the competitiveness of its market offerings. Pre-calculations indicate cost savings of at least 25%, which can be realized with autonomous driving. Additionally the time constraints from the Working Hours Act can be overcome.

A significant share of the issues mentioned above is due to the limitations in wagon technology, including not only the “vehicle” but also the “communications” from the vehicle with the logistics control room and the efficiency and lead time of the infrastructure processes to manage freight rail traffic. These limitations lead to uncompetitive offerings to the logistic market and a “frozen” business structure in the rail freight business. The potential provided by state-of-the-art locomotive technology (interoperability and efficiency) cannot fully be exploited as long as the following limiting factors remain:

- Train weight and speed are limited by the strength of standard couplers
- Unsatisfying train dynamics due to standard couplers and a poor manually controlled braking systems (UIC standard) prevent exploiting the remaining capacity of the network
- Missing electrification of freight wagons limits the market access as attractive market segments and the digital integration in the leading logistic process is not possible (electronic freight orders and tracking)
- Payload-deadweight ratios are poor, especially in the market most emerging segments of containerized single goods transports.
- Bad or no visibility of goods towards shippers and end-customers due to not integrated data processing along the supply chain – lack of TAF TSI implementation;
- Long- und unreliable lead-time in hubs and marshalling yards accompanied with high operational costs
- Lack of optimisation of automated processes in the nodes and on the lines



The core objective of Innovation Programme 5 (IP5) is to increase competitiveness of European Rail Freight.:

1. On the one hand to maintain and defend its market position in the transport segments of today making use of digitalisation, and
2. On the other to open up new market segments so that in total an effective gain of the overall market share becomes reality.

To achieve that objective, IP5 will follow a dual strategy concept. IP5 comprises several development tasks in the field of wagons, its equipment or components, operational procedures, automation and algorithms, which are gathered in TD5.1 to TD5.6 (figure 7) and support either one of those strategic directions or both. However, the mere support of technological advancement is not sufficient to ensure success. This is illustrated by the following examples:

- The development of new equipment, such as a wagon enabling higher payloads and transport speeds, may appear desirable at first sight, but the efforts are in vain if the improvements come at a cost, which rail customers are not ready to pay.
- Substantial technological advancement in some areas may only be achieved if the requirement for compatibility between new and existing equipment is abandoned. This implies the need for a well-founded migration concept towards new technology, especially in areas with considerable investments and long life cycles.

With this regard, IP5 perceives the rail freight transportation as an integral part of the transport and logistic supply chain (e.g. different business models depending on the value of the goods), which has to meet the requirements of the transport market today and in the future under progressive socio-economics and environmental constraints.

#### **Definition and justification of the objective**

TD5.0 will focus on using the input from SmartRail and findings from Capacity 4 Rail, and other projects, to serve the following purposes:

- a) It will provide guidance as to how to implement new technology developed in IP5 on a large scale (migration plan)
- b) It will exploit all relevant results from other ongoing or past projects to allocate the budget in a efficient way and support the activities in the other TD's to stay on track with reviews or other suitable measures.



### **Specific achievements to be delivered by TD5.0 (objectives table)**

1. Overview of relevant segments of the transport and logistics market which are currently served by rail (fully or partly) and of segments which could be served with appropriate technical improvements and adequate business models (focus on wagon design and components)
2. Definition of features and quality/cost parameters (KPIs) required by customers and railways/logistics service providers to improve the competitiveness of rail freight and to realize the potential of rail freight to a greater extent.
3. Development of Migration Plans for the introduction of new technologies, equipment and services to be developed in TD5.1-TD5.6 including compatibility issues. The focus will be on the European-wide roll-out of key technologies following Shift2Rail. This will include the demands of TAF/TSI standard data exchange.
4. Addressing short-term improvements for increased competitiveness of the freight rail sector referring to the SmartRail project.

### **Linkage and alignment with the Shift2Rail Master Plan**

The objectives of TD5.0 are aligned with the Shift2Rail Master Plan, as shown in Table 22:

***Table 22: Alignment of TD5.0 objectives with the Shift2Rail Master Plan***

S <sup>2</sup> R Objectives	TD Objectives	Practical Contribution
Enabling [the rail market] to (re-)enter into new/lost market segments (Master Plan V 1.0, p.42)	Definition of KPIs to improve the competitiveness of rail freight in close cooperation with SmartRail. Migration plan	Compilation of market requirements for services involving rail transport, including the demand for features enabled by new technology Recommendations for migration to new equipment, wagons and services and for handling compatibility issues
Target[ing] the market segments where the progress is reachable in the short term and market segments with an important growth potential in terms of transport and revenue potential (Master Plan V 1.0, p.42)	Quantification of segments which should be served with technological improvements and adequate business models in close cooperation with SmartRail.	Characterisation of relevant market segments by size and qualitative volume development estimate

All results of TD5.0 will indirectly contribute to achieving the objectives of the other TDs in IP5 (especially TD5.1 and TD5.3), for which they provide a basic specification. (e.g. lower investment costs and reduced operating costs (Master Plan V 1.0, p.44)).





### 5.5.1.2. Technical ambition of TD5.0

The first aim in TD5.0 will be to exploit available findings from existing studies and projects to the greatest extent possible. Building on the TAF TSI and information from existing sources, TD5.0 will consider the impact of novel equipment to be developed in IP5 and the new services and business models enabled by its introduction. Table 23 gives an overview of the advancement of the intended activities in TD5.0 beyond existing studies.

**Table 23: Overview of intended achievements of TD5.0 beyond existing studies/state-of-the-art**

Field	State-of-the-art including relevant projects or studies funded by the EU	Intended approach by Shift2Rail to go beyond state-of-the-art/existing studies
<b>Wagon and component development</b>	SPECTRUM project (Solutions and Processes to Enhance the Competitiveness of Transport by Rail in Unexploited Markets), 2012-2015	Consideration of a synthesis of advanced features and of more advanced technology to be developed in IP5
<b>Business Models</b>	Smart-Rail project (Smart Supply Chain Oriented Rail Freight Services), from 2015	Extension of analysis to services enabled by new equipment to be developed in IP5 and not considered in the Smart-Rail project
<b>Single wagonload transport</b>	Studies and recommendations for the development of single wagonload traffic, e.g. "Study on Single Wagonload Traffic in Europe", PriceWaterhouseCoopers/University of Rome "La Sapienza", 2012-2014	Consideration of a higher degree of automation enabled by the technologies to be developed in IP5 (including last-mile delivery, and automation in sidings and marshalling areas)

### 5.5.1.3. Specific Demonstration activities and contribution to ITDs/SPDs

TD5.0 serves as a support for the subsequent TDs in IP5 and does not include a technology demonstrator in the strict sense. The tasks of TD5.0 is to serve the needs of TD5.1-TD5.6, regarding certain prerequisites for better performance. Furthermore TD 5.0 will contribute to a migration plan.

### 5.5.1.4. Impact of TD5.0

The expected impact of TD5.0 is an alignment of the specific objectives pursued in TD5.1-TD5.6 with the requirements of railways and their customers. Thus, the results from TD5.0 increase the opportunities for a successful transfer of the results from TD5.1-TD5.6 to the market. The expected strategic impact of TD5.0 is summarized in Table 24.

**Table 24: Strategic impact of TD5.0**

Strategic Aspect	Key Contribution from TD5.0
<i>Support the competitiveness of the European rail industry</i>	<ul style="list-style-type: none"> <li>Specification of market prerequisites for development of automated concepts and equipment in TD5.1-TD5.6 which will have advanced capabilities compared to the state-of-the-art and thus strengthen the European rail industry</li> </ul>
<i>Compliance with EU objectives</i>	<ul style="list-style-type: none"> <li>Promotion of modal shift, capacity/energy improvements per payload through enhancing the performance of rail freight (indirectly by contribution to TD5.1-TD5.6); implementation of respective EU law – TAF TSI</li> </ul>
<i>Degree of maturity of the envisaged solutions</i>	<ul style="list-style-type: none"> <li>The Analytic nature in TD 5.0 and the connection to SmartRail etc should be seen as a basis for reaching higher TRLs in TD5.1-TD5.6, to which they contribute. Beyond that the migration plan will facilitate the dissemination to real operations.</li> </ul>

### **5.5.1.5. Implementation of the work programme**

#### **Short description of the methodology**

The methods applied in TD5.0 will comprise the review of existing studies and results from past or ongoing projects as well as the collection of new market data from SMARTRAIL and findings also from Capacity4Rail. The information obtained in these projects will result in an initial set of recommendations which will serve as an input for the development work in TD5.1-TD5.6. If required, the initial findings and recommendations will be updated considering the progress of TD5.1-5.6.

#### **Work breakdown scheme**

#### **Content of each work package**

##### **Task 5.0.1 Identification of market segments**

This task will comprise the compilation of an overview of all relevant segments of the freight market. It will include all transport segments in which rail currently has a significant market share.

In addition, the investigation will also cover segments in which rail does not currently play a significant role due to poor performance or due to the lack of appropriate equipment and services as for instance express/overnight transport/groupage.

The results will comprise an approximate quantification of the size of each market segment as well as a qualitative description of the development of each segment. The overview will help to identify those segments in which a potential to shift volumes from other modes to rail thanks to improved equipment and services/business models is expected.

The analysis will integrate the findings from existing studies or work from complementary projects to the greatest extent possible, in particular the SPECTRUM project and the Smart-Rail project funded through the H2020 programme.

The contribution of the S2R members will cover the following:

- Identification of market segments

- Overview of all relevant segments of the rail freight market; specification of growth potential in existing segments and segments to be addressed by the novel wagon and locomotive for market uptake of freight rail business; dialogue with decision-makers in the relevant segments to validate results
- Evaluation of the outcome of past and ongoing projects of relevance for the benefit of S2R IP 5. Interaction with Smart Rail project, for example performing common interviews with stakeholders.

Moreover through the Smart Rail Project (“living labs”) the work will cover the area of short-term wins for shippers, customers and operators.

#### **Task 5.0.2 Development of Specifications and Key Performance Indicators**

The work of task 5.0.2 will result in the definition of KPIs and KPI improvements required for increasing the attractiveness of rail freight. The focus will be two-fold:

- a) Market segments which are traditionally rail-affine
- b) Market segments in which rail transport currently has a weak position, but is considered capable of doing better, provided that it can offer a better performance.

The aim behind the investigation is the intended development of relevant KPIs which also can be adopted from SMARTRAIL living labs. The contribution of the S2R members will cover the following:

- Definition of KPI’s, with focus on required capacity/payload, communication capabilities, freight electrification, maximum speed and train dynamics
- Quantification of the estimated benefits of the novel wagon in the form of KPI’s based on model calculations (novel wagon versus typical existing wagons) with focus on specific cost of transport and operational costs
- Contribution to the development of a widely accepted freight transport oriented economics assessment method (LCC/CBA/ specific vehicle costs per km) including whole-railway-system LCCs & management-operation-related costs and considering country/operator specific aspects all relevant stakeholders inside S2R IP5 and outside will be involved with the goal to achieve sector wide acceptance – link to H2020 Roll2Rail WP4 Universal cost model and S2R CCAs

In addition there will be an evaluation of the outcome with the stakeholders of Smart Rail project.

#### **Task 5.0.3 Migration plan**

A proposal will be elaborated for the market introduction and European wide roll-out of the solutions to be developed in IP5. This task will ensure that technological migration plans will be developed for key technologies and solutions which will be developed in TD 5.1 -TD 5.6. With the overall vision of digitalisation and automation of rail freight, the migration plans will have a reasonable timeline with logically steps for the market uptake of the new solutions which can be used as a guideline for the European freight sector.

Task 5.0.3. Migration Plan

The contribution of the S2R members will cover the following:

- Definition of migration plans with focus on all TD development, particularly:
  - Automated Train Operation
  - (novel) automatic couplers
  - Core market and new market wagon 2020
  - Condition based maintenance
  - freight propulsion systems for the freight loco of the future incl. last mile concepts and legacy shunters
- Safeguarding that the migration plan will include core technologies, which are in line with the operational requirements and TAF/TSI and also a solid plan for especially automated couplers and asset intelligence

Moreover through the Smart Rail Project (“living labs”) the work will cover the area of short-term wins for shippers, customers and operators. In addition there will be an evaluation of the outcome with the stakeholders of Smart Rail project.

**5.5.1.6. Planning and budget**

As the findings of TD5.0 are intended to serve as a basis and guideline for the development work to be accomplished in TD5.1-TD5.6, the intention is to deliver initial results as early as possible (i.e. by Q3/2016). Subsequently, the participants of TD5.0 will maintain close contacts with the participants of the other TDs of IP5 and monitor and evaluate the technological development work on a regular basis (i.e. through annual meeting periods). Figure 98 illustrates the planned sequence of tasks.

**Figure 98: Gantt chart of TD5.0**

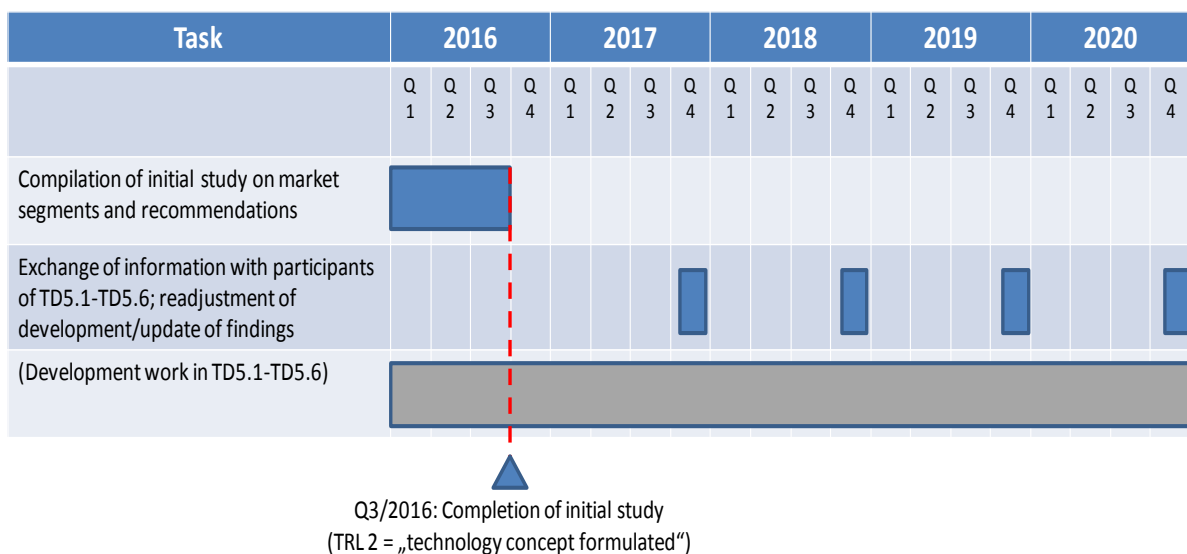



The estimated budget for the TD is around 6.9M€ including the Smart Rail project.

## **5.5.2. TD5.1 Freight electrification, brakes and telematics**

### ***5.5.2.1. Concept and objectives***

Previous EU funded projects such as ON-TIME, SPECTRUM, SMARTRAIL, CAPACITY4RAIL have already analysed and identified strategic areas which will enable an increase in the transportation market share. The strategic areas for the rail freight transportation are a combination of new functionalities with a considerable improvement in performance. These strategic areas are listed below:

- Increased reliability and punctuality
- Reduction of transportation cost
- Increased availability
- Increased flexibility
- Real time monitoring and tracking of cargo (especially important for dangerous, perishable and temperature sensitive goods)
- Better transportation conditions
- Reduction of noise

To achieve improvements in these strategic areas, condition-based maintenance of locomotives and wagons, telematics and key components such as automatic couplings of the wagons have to be developed.

Moreover, the introduction of sensors for the wagon monitoring system and a better understanding of the wearing of components, as well as the big data analysis techniques is enabling the better scheduling of the maintenance works [OPTIRAIL 2015]. This is expected to bring reductions in the order of the 10% of the maintenance costs.

Therefore, within TD5.1 it is foreseen the development of three focus areas which are illustrated in the next figure:

**Figure 99: Focused market areas in TD5.1 Freight electrification, brakes and telematics**

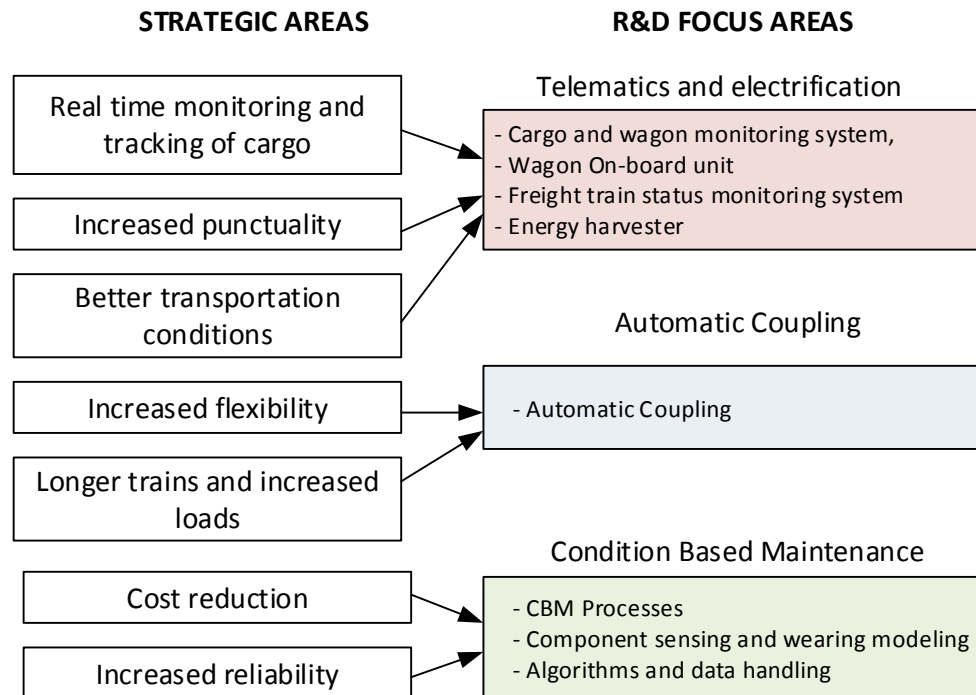

**Technological output to be delivered by this TD:**

- Telematics applications and electrification built on TAF TSI standards will provide new and innovative functionalities on real time monitoring and tracking of cargo for logistic purposes and provide information to TMS about the convoy (end of train – EoT), real time conditioned monitoring (wagon and goods), automatic train set-up functionalities and information to the driver.
- Automatic coupling and decoupling including power, air and data connectivity, which will serve electrification for condition monitoring of wagon and goods. That will enable an increased flexibility in the convoy composition.
- Development of an end-to-end solution for Condition-based maintenance, including processes, data handling, analytics, dashboards and a complete condition-based maintenance regime for a specific locomotive fleet covering the main modules traction motor, power conversion and train protection.

**Specific achievements to be delivered by this TD:**

- Reduce cost and increase technical availability of assets (locomotives and wagons)
  - Reduce maintenance costs downtime cost and operating cost

- Increase technical availability
- Optimize maintenance operations through automation
- Provide real time information, alert notifications on goods, wagon, locomotive and train conditions
  - Improve LCC, and goods and vehicle real time health monitoring, wagons automation, control and monitoring of dangerous goods.
  - Enable trains to interact and exchange information with Ground Systems, improve reliability since better ETA estimation
  - On board power harvesting (sensors), smart power sources (dynamic condition) and power management (train trip and rail terminals) in interaction with ground systems.
- Increase of the load capacity and degree of automation for freight trains
  - Heavier maximum trainload
  - Remote controlled decoupling and operating

The following table shows how the activity proposed will contribute to the achievement of the S<sup>2</sup>R objectives as stated in the S<sup>2</sup>R Master Plan:

**Table 25: S2R objectives addressed in TD5.1 Freight electrification, brakes and telematics**

S <sup>2</sup> R Objectives	TD Objectives	Practical contribution (how)
Improved services and customer quality	Increased reliability and improved capacity	Condition monitoring and condition-based operations for improved availability, reliability and punctuality as well as status monitoring and localisation for vehicle and goods, based on new value-added service features, such as electric power supply/connection
Reduced system costs	ROI increase, reduction of operating and maintenance costs, reduction of externalities	Condition based maintenance to improved resource productivity, using components until end of their actual lifecycle, reducing LLC by minimum 15%. Increased load capacity to reduce the operational costs
Enhanced interoperability	Enhanced interoperability	Coupling standard for European freight wagons. Standardisation, vehicle & goods status data usage
Simplified business processes	Improved approval process, reduced design verification and testing effort, predictive maintenance, modularity	Standard approval process for condition-based maintenance Automated condition monitoring and diagnosis for optimised maintenance and fleet management Real time information of the convoy, cargo and transportation space availability

### 5.5.2.2. Technical ambition of the Freight electrification, brakes and telematics demonstrator

#### Description of relevant state-of-the-art, including reference to past EU projects

The most relevant EU projects are listed in the following table:

**Table 26: Overview of intended achievements of TD5.1 beyond existing studies/state-of-the-art**

Project	Input
<b>SPECTRUM (2011 – 2015)</b>	High level requirements of freight transportation Freight train that behaves like a passenger train in terms of speed, acceleration, braking and has a standardized universal power supply system
<b>MARATHON (2011-2014)</b>	Analysis of increasing in train length, speed and weight on constrained rail infrastructure
<b>FEBIS</b>	Acronym of Freight Electronic Brake and Information System was a project launched in 1999, the purpose of this project was to specify, conceive and develop a demonstrator of a freight train 2.250m long, managed by an electronic communication and braking system, able to be operated on the European Network.
<b>FFZ</b>	Multiple radio remote control of locomotives in train sets
<b>CAPACITY4RAIL (2013-2017)</b>	CAPACITY4RAIL (C4R) is a EU FP7 funded project that targets the question “How to obtain an affordable, adaptable, automated, resilient and high-capacity railway; for 2020, 2030 and 2050?”

The main causes for not reaching the ultimate goal are considered to be:

- Not integrating the key strategic areas in the complete value of chain
- Lack of common system for Condition-based Maintenance
- Trying to optimize the rail freight transportation system from a narrow/local perspective

The main interaction envisaged, both from the point-of-view of technologies employed and of interaction in performance and objectives, are:

- IP5 – TD5.0 “Implementation strategy and business analytics
- IP5 – TD5.2 “Access and operations”
- IP5 – TD5.3 “Wagon design”
- IP5 – TD5.4 “Novel terminals, hubs, sidings and marshalling yards”
- IP5 – TD5.5 “High Performance Freight Train”



The following table summarizes how this TD will progress the state-of-the-art and overcome today's limitations and difficulties:

**Table 27: Ambitions and advance beyond state-of-the-art for TD5.1**

State-of-the-art	Ambitions and expected advance beyond state-of-the-art
Wagon On-board unit (wOBU)	Modular, mechanically robust, integrated antennae for wireless communications, connection to local power loads, energy management system, wagon monitoring system etc. A network gateway will provide access to WSN services from external systems. Specific communication services will be implemented and deployed over the train wireless back-bone infrastructure in order to fulfil data exchange requirements across train composition, coming from different applications envisaged in TD (condition base maintenance, status monitoring, etc.).
Wagon monitoring system (WMS)	Smart cost efficient sensors HW and SW for wagon and locomotive components monitoring and cargo monitoring. New algorithms for vehicle status monitoring based on sensor fusion and vehicle-track interaction assessment will be developed in order to detect abnormal circumstances
Freight train status monitoring system (FTSMS)	Information to the driver about the wagon and cargo status. Display of real time information about convoy composition, integrity (EoT), efficient driving, max braking profiles and noise sensitive driving.
Energy management system (EMS)	Ultra-efficient, robust, autonomous power generator providing basic cost-efficient freight wagon electrification is attached to a bogie's axle box bearing In combination with an on-board unit and energy-management-optimised battery system, different functionalities like end-of-train device and wireless communication to wagons, loco and ground systems will be developed and integrated
Automatic Coupling (AC)	Complementary to CBM, rail freight requires innovation of couplers for smart electrification of wagons. Automatic coupling will enable to integrate also wagons in the CBM framework, to enable e.g. longer trains (TD 5.5) and train automation (TD 5.6) to increase load capacity and to reduce train composition time. Automatic coupling will include heavy load, electric and data connectivity and minimize manual work load through automatic coupling and remote-controlled decoupling
Condition based maintenance (CBM)	Development of an end-to-end solution for predictive maintenance, including processes, data handling, analytics, dashboards, for locomotives and wagons. Beyond data handling, statistical and empirical analysis and development of neuronal prognostics, the core innovation of PM takes place at the process level, including new roles and responsibilities in the interaction of the areas asset, fleet and maintenance management, but also new forms of collaboration with regulative authorities that need to approve of data-based dynamic changes to technical threshold values. Also, development of a complete predictive maintenance regime for a specific locomotive fleet covering the main modules traction motor, power conversion, and train protection system. Definition of maintenance procedures and migration process following standards EN 50126: and DIN 27201 part 1.

### 5.5.2.3. Specific Demonstration activities and contribution to ITDs/SPDs

**TD5.1 – DEMONSTRATOR 1:** Integration of focus areas of telematics and electrification, automatic coupling of TD5.1 in the new wagon design developed in TD5.3

- Specifications and scenario definition



- Technology development (up to TRL4):
  - wagon On-Board Unit
  - Wagon Monitoring System
  - Energy management system
  - Automatic Coupler
  - Wagon design
- Integration
- Validation (up to TRL6)

**TD5.1 – DEMONSTRATOR 2:** Integration of focus area telematics and electrification of TD5.1 in already available wagons with TD5.2 and TD5.4

- Specifications and scenario definition
- Technology development (up to TRL4):
  - wagon On-Board Unit
  - Train integrity, End of Train device (EoT)
  - Real time network management
  - Intelligent gate terminals
- Integration
- Validation (up to TRL6)

**TD5.1 – DEMONSTRATOR 3:** Condition-based maintenance of locomotives and wagons (TD5.1 and TD5.5)

- Specifications and scenario definition
- Technology development (up to TRL4):
  - Wagon Monitoring System
  - Condition Based Maintenance
- Integration
- Validation (up to TRL6)

The following table summarises the contribution of TD 5.1 to the different ITDs of Shift2Rail:

**Table 28: contribution of TD 5.1 to the different ITDs**

TD	Focus Areas TD5.1	Focus areas other TDs	Demonstrator		Focus of activity
			Market	TRL	
TD5.1- Electrification, brakes and telematics	Automatic coupling, and telematics and electrification	TD5.3- New wagon design	Freight	6	Automatic coupling, electrification, wagon on-board unit and on-board unit integrated with the new wagon design
	Telematics and electrification	TD5.2- Real time network management	Freight	6	Integration of the information provided by the convoy with the network management
	Telematics and electrification	TD5.4- Intelligent gate terminals	Freight	6	Integration of the information provided by the convoy within the terminal operations
	Condition based maintenance	TD5.5- Locomotive	Freight	7	Condition based maintenance of wagons and locomotives

#### 5.5.2.4. Impact of the Telematics, electrification, automatic coupling and condition based maintenance

The following tables summarises the impact contributions of TD 5.1 to the S2R objectives with respect to technical and strategic aspects:

##### Technical Impact

**Table 29: Technical Impact of TD5.1**

S2R objectives	Strategic impact
Improved reliability	Condition based maintenance based in wagon monitoring system capturing data, will not only decrease maintenance costs, but will also reduce the failure possibility bringing an increase in the reliability and availability of the assets
Enhanced capacity	New automatic coupling will enable <b>longer &amp; heavier trains</b> .
Customer experience	<b>Electrification and telematics</b> that provide vehicle & goods status monitoring as well as localisation, will increase service quality <b>for vehicle operators, logistics providers, logistical providers within dangerous goods and other customers</b> .
Reduced operating costs	<b>Condition based maintenance</b> strategies <b>will reduce LCC for vehicles by 10%</b> . Potential additional <b>LCC savings are expected</b> due to reduced noise and its consideration in <b>Track Access Charge</b> models.
Externalities	The pass-by <b>noise</b> and <b>environmental impacts</b> will be reduced thanks to providing information for driving and braking profile customized for the actual convoy characteristics
Enhanced interoperability	Newly developed technologies will contribute to <b>standards</b> (e.g. TSI TAF). Vehicle & goods status data usage will yield higher <b>operational interoperability</b> .
Simplified business processes	<b>Standardisation</b> of integration of train condition data into <b>standard diagnostic systems</b> and <b>new</b> freight wagon design <b>components</b> . Sensor data enable <b>predictive maintenance</b> , reduce maintenance costs and lead to higher operational reliability and interoperability.

## Automatic coupler as enabler

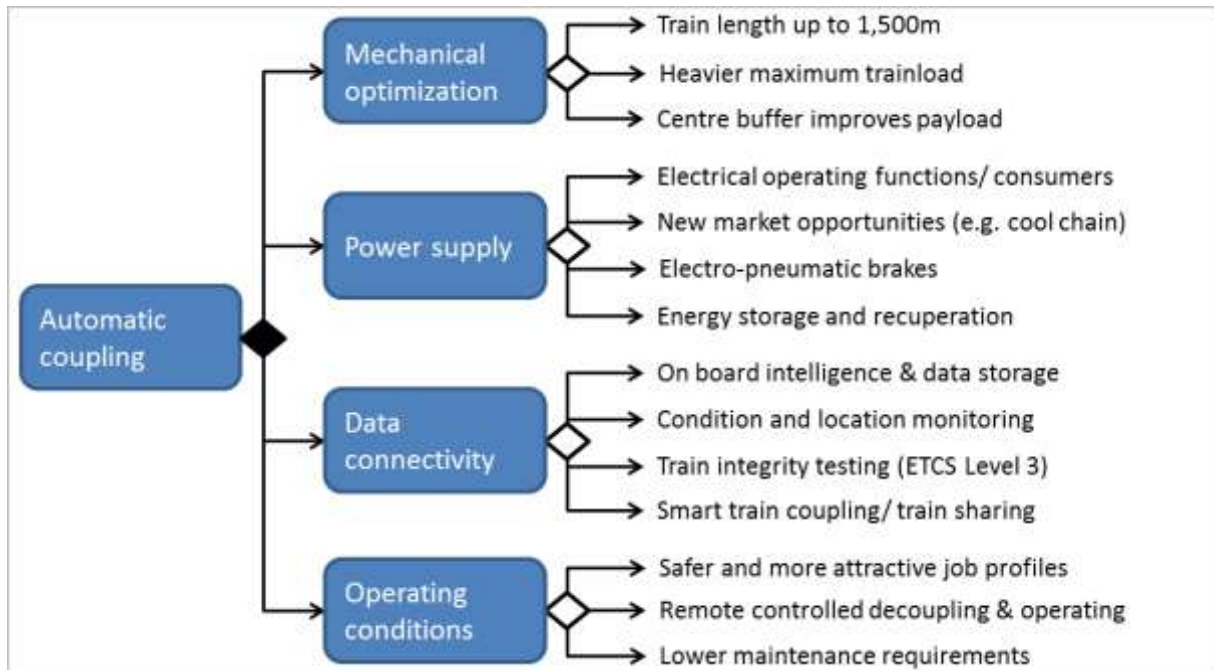

**Strategic Impact****Table 30: Strategic Impact of TD5.1**

Strategic Aspect	Key Contribution from the TD
<i>Support the competitiveness of the EU industry</i>	<ul style="list-style-type: none"> <li>• Provide real time information, alert notifications on goods and/or train conditions               <ul style="list-style-type: none"> <li>○ Improve LCC (20% reduction), and goods and vehicle real time health monitoring, wagons automation, control and monitoring of dangerous goods.</li> </ul> </li> <li>• Enable trains to interact and exchange information with Ground Systems               <ul style="list-style-type: none"> <li>○ New non-conventional train configurations validation before service tests (time reduction 10%-50%). Improve reliability since better ETA estimation</li> </ul> </li> <li>• Reduce train setup with higher grade of automation time in marshalling yards and achieve a design corresponding to efficient train compose               <ul style="list-style-type: none"> <li>○ Improve “frequent variable composition” train capacity (25% increase train capacity)</li> <li>○ Improve “bulk train” capacity diagnosis (reduction up to 50% service disruption and safety issues)</li> </ul> </li> <li>• Improve dynamic train performances, on conventional trains and/or on trains supported by electronic technologies               <ul style="list-style-type: none"> <li>○ Train setup and uncoupling automation, longitudinal dynamics improvements (reduce 75% damage to the railway infrastructure)</li> <li>○ Optimisation of service intervals (condition-based maintenance)</li> <li>○ Reduction of energy consumption through efficient driving profile based on real time traffic information and actual convoy characteristics (10% reduction).</li> </ul> </li> </ul>
<i>Compliance with EU objectives</i>	<ul style="list-style-type: none"> <li>• Promotion of modal shift: A big impact brought by the implementation of these new technologies by demonstrating the economic benefits of new improved logistics making rail freight more attractive</li> <li>• Support to capacity increase: as mentioned above this is allowed by EoT-train integrity functionality</li> <li>• Greening of transport through energy reduction and lower noise can be achieved by providing information with the freight train status monitoring system about the driving and braking profiles adapted for specific characteristics of the freight convoy</li> </ul>
<i>Degree of maturity of the envisaged solutions</i>	Currently most of the proposed technologies are in TRL 3-4. At the end of Shift2Rail it is expected that the successful concepts are brought to TRL 6 to 7 (automatic couplings).

**5.5.2.5. Implementation of the work programme**

The work in this TD embraces the development of the three different focus areas previously described (Telematics and electrification, automatic couplers and Condition-based maintenance).

This work, that will mostly run in parallel, is divided in 5 different tasks; T5.1.1-High level specification definition, feasibility analysis and preliminary testing, T5.1.2-Conceptual design /architecture



definition, T5.1.3- Development, implementation and verification, T5.1.4- Integration, T5.1.5- Demonstration.

The first task, T5.1.1, is intended to be dedicated to the definition of technical specifications for the different focus areas, to the characterisation of the environment (EMC, noise, vibration, cargo loads, etc.), to do exploratory testing and feasibility analysis. During this phase, the demonstration scenarios will be defined in detail.

During the task T5.1.2 (in coordination with TD5.3 for telematics and automatic coupling, and in coordination with TD5.2, TD5.4 and TD5.5 for telematics and condition based maintenance respectively, the architecture or conceptual design of the different focus areas should be defined. In this phase, high level simulations of the focus areas with the environment are foreseen to verify their performance in a virtual environment. The different areas will reach a TRL3.

During the task T5.1.3, the detailed design of the components will be carried out. It is also foreseen their implementation and the unitary testing. The different components will reach a TRL4.

During the task T5.1.4, the different components will be integrated to provide a high level functionality (e.g. telematics integrated in Real time network management TD5.2) and will be cross-verified. The different components will reach a TRL5.

During the task T5.1.5, the different components once integrated will be validated through demonstration activities. The different components will reach a TRL6.

### **Description of Tasks:**

#### **T5.1.1- High level specification definition, feasibility analysis and preliminary testing**

The contribution of the S2R members will cover the following:

- Analysis and comparison of the existing systems,
- Economic evaluation,
- Specification definition (operational & technical),
- Migration strategy definition and the communication strategy.

*T5.1.1.2- High level specifications for the telematics and electrification area (energy harvester, wagon on-board unit, wagon monitoring system and freight train status monitoring system)*

The contribution of the S2R members will cover the following:

- Specification analysis and definition for:
  - the energy management system and operational concepts.
  - conceptual design and convoy logistic service (TD 5.0) in the railway domain as well as domains with high potential for technology transfer and the characterisation of operational environment (EMC, noise, vibration, temperature, ...)



- wireless communication backbone in the freight convoy and gateway to infrastructure for different applications
- EoT functionality further requirements/needs coming from IP5 for addressing at best the development of the EoT device within the TD2.5.

*T5.1.1.3- Specification of rail freight applications for condition-based operation, e.g. predictive maintenance of freight locomotives and wagons, condition-based fleet planning*

The contribution of the S2R members will cover the following:

- Analysis of processes in rail freight and value analysis for condition-based operation. This activity includes analyzing of current maintenance practice (processes, technology and interfaces) in exchange with other European railway operators. Best practices of other industries will be analyzed as well. It is also foreseen the definition of use cases and strategies for condition-based operation. Then, the specification and periodisation of rail freight applications and dashboard solutions required. It is also foreseen the specification of condition monitoring reports and data requirements and finally the specification for scenarios coming from TD 5.0.
- Definition of the use cases and strategies for condition-based maintenance.

#### **T5.1.2 – Conceptual /architecture design**

*T5.1.2.1- Conceptual/architecture design of the Automatic Coupling*

The contribution of the S2R members will cover the conceptual design of the automatic coupling.

*T5.1.2.2- Conceptual/architecture design of the telematics and electrification (energy harvester, wagon On-board Unit, wagon monitoring system and freight train status monitoring system)*

The contribution of the S2R members will cover the definition of system architecture and conceptual design.

*T5.1.2.3- Conceptual/architecture design of the Condition Based Maintenance*

The contribution of the S2R members will cover the following:

- Design of the architecture of the CBM system with regards to data handling and analysis, including the process of value stream analysis and identification and prioritisation of top-components and top-transfers/feedings (fleet management) to the maintenance station with the highest impact on technical locomotive and wagon availability as well as on costs aspects.
- Design of the architecture of the web-interface for freight wagon data visualisation, including a standardised interface for existing external systems and maintenance systems.
- Design of the architecture for the data handling and algorithms implementation also scheduling/ planning algorithms for predictive maintenance can be a consideration.





### **T5.1.3 – Detailed design/development, implementation and unitary testing**

*T5.1.3.1- Detailed design/development, implementation and unitary testing of the Automatic Coupling.*

The contribution of the S2R members will cover the detailed design/development, implementation and unitary testing of the Automatic Coupling.

*T5.1.3.2- Detailed design/development, implementation and unitary testing of telematics (wagon on board unit, wagon monitoring system and freight train status monitoring system)*

The contribution of the S2R members will cover the following:

- Development and integration of an axle-box generator in combination with a battery system.
- Enhancement of the already available wagon on-board unit.
- Development of the synchronisation of measurements from the wagon monitoring system with time and location which will make use of very low cost GNSS receiver and will use collaborative algorithms with other wOBU as well as inertial and magnetic sensors.
- Development of the wireless communication for the protocols that will constitute the backbone of the train borne communications and the gateway to the infrastructure.
- Design, integration and unitary testing of smart sensor types of cargo monitoring system.
- Investigation of sensor reduction.
- Development of sensor setups and methods/algorithms for real-time evaluation of current noise and vibration status of wagons and train by on-board measurements, and development of methods for the evaluation of obtained (historical) wagon and train noise status information in dependency of train and track conditions (input for train operations)
- Identification of the requirements for the design of wheel sets to accommodate the innovative health monitoring system and design of the corresponding component
- Development of algorithms for vehicle diagnosis and of methods for the evaluation of obtained (historical) wagon and train noise status information in dependency of train and track
- Development (with regard to the Freight Train Status Monitoring System (FTSMS)) of the computing, positioning and communication equipment, the Human-Machine-Interface (HMI) including the analysis of existing and upcoming specifications, standards, and regulations in the railway domain as well as domains with high potential for technology transfer (automotive, aviation, etc.) for Human-Machine-Interfaces (HMI) / human-centered design.
- Development of the convoy integrity functionality based on communication protocols and the integration of the EoT functionality development of specific application layer over WSN backbone for implementing automatic train set-up and train integrity control systems. In this activity, the testing scenarios will be defined and the employment of train simulator studies is proposed.



Open calls are foreseen for the development, integration and testing of the CPU HW and FM with new functionality including self-diagnostic, the wired train borne communication HW and protocols, and the communication HW and protocols to the infrastructure. Moreover appropriate simulation models have to be developed to validate specific characteristics of the FTSMS components. A special focus should be set to the interfaces and the data volume to be handled by the FTSMS. Open calls are also foreseen for the development of the HW and FW of the FTSMS including the power supply and mechanical casing.

*T5.1.3.3- Detailed design/development, implementation and unitary testing of the condition based maintenance as well as for the development of scheduling/ planning algorithms for predictive maintenance.*

The contribution of the S2R members will cover the following:

- Development of the framework for data processing and classification of components for CBM in accordance to DIN 15380-2 and DIN 15380-4, assignment of all maintenance tasks to the identified components and transfers/feedings (fleet management).
- Analysis of data of a specific locomotive fleet, threshold value identification and reference variables for relevant components, definitions of limits for the same and validation and examination of the new maintenance programme on component basis. Development of condition-based maintenance processes and algorithms.
- Development of a web-interface for freight wagon data visualisation, including a standardised interface for existing external systems and maintenance systems.
- Development of big data processing algorithms for wheel and axles wearing modelling and data interfaces for data reconciliation from different sources (historical data, maintenance workshop data, real time information, etc).

Open calls are foreseen in this area for the development of the real time data base structure and in the component wearing modelling as well as for the development of scheduling/ planning algorithms for predictive maintenance.

#### **T5.1.4- Integration of components**

##### *T5.1.4.1- Integration of the Automatic Coupling*

The contribution of the S2R members will cover the integration of the automatic coupling, in the new wagon design and currently available wagons.

##### *TD5.1.4.2- Integration of the telematics and electrification*

The contribution of the S2R members will cover the following:

- Integration of the telematics (WMS, wOBU, FTSMS) within the new wagon design and currently available wagons, with other information systems in TD5.2 and TD5.4. It is also foreseen the definition and realisation of test scenarios with research vehicles in combination with other systems from TD5.2 and TD5.4.

- Integration of new wheels and axles with the wagon monitoring system, in the new wagon design.

#### *TD5.1.4.3- Integration of the CBM components*

The contribution of the S2R members will cover the following:

- Specification of a target process including an approval process for diagnosis-based maintenance and a migration-process for all relevant stakeholders.
- Aggregation of data from locomotive and wagons via onboard units, comparison actual values and threshold values (system based) and deduction of specific maintenance tasks if threshold value is reached (system based).
- Integration of the web-interface for freight wagon data visualisation, including a standardized interface for existing external systems and maintenance systems.

#### **TD5.1.5- Demonstration activities**

The demonstration activities intended to be carried out have been previously described in the demonstrator description section. Nevertheless they are summarized in the following points:

DEMONSTRATION ACTIVITY 1 – **TRL6** – telematics and electrification, automatic coupling with new wagon design (TD5.3)

DEMONSTRATION ACTIVITY 2 – **TRL6** – telematics and electrification with network management (TD5.2) and intelligent gate terminals (TD5.4)

DEMONSTRATION ACTIVITY 3 – **TRL7** – Condition based maintenance – In a live environment, the CBM system will, based on a CBM regime for a specific locomotive class, assign maintenance tasks to the relevant stakeholder.

#### ***5.5.2.6. Planning and budget***

Tasks	Name	2016	2017	2018	2019	2020
TD5.1.1	High level specification definition, feasibility analysis and preliminary testing	■				
TD5.1.2	Conceptual / architecture design		■			
TD5.1.3	Detailed design, implementation and unitary testing		■	■		
TD5.1.4	Integration of components				■	
TD5.1.5	Demonstration activities					■

The estimated budget for the TD is around 16.4 M€.

### **5.5.3. TD5.2 Access and Operation**

#### ***5.5.3.1. Concept and objectives of Access and Operation***

An improved accessibility to rail freight and the provision of highly reliable and flexible solutions is of highest importance for the competitiveness of the system, especially in market segments like the maritime and continental intermodal transport, where the truck is a very strong competitor. The objective is to get to the same level of flexibility and accessibility and to be even better concerning



reliability. Therefore, in addition to the various hardware developments in other TDs, this TD will focus on improved service planning and operation, which also supports a better utilisation of the available capacity.

Within the digitalisation scope for future rail freight, the proposed TD serves to optimise access and operations of local hubs (e.g. marshalling yards and sidings) which are essential but cost-intensive subsystems for rail freight business. Local hubs, which have collecting and distributing function in the rail freight system along the European corridors, are key elements for delivering last mile operation and have a decisive impact on punctuality, availability and cost efficiency of rail freight services. Large local hubs consist of a complex infrastructure of tracks, switches, crossings and infrastructure service facilities such as gravity humps and wagon weighbridges. For planning and steering of transit through local hubs, a complex target system exists for punctual fulfilment of operational requirements, e.g. wagon interchange and loading point operations. The optimisation of hubs operations should take into account the available new technologies

It is important that future rail freight solutions are developed to optimise the overall transport time; this include a reduction of the handling and set up time at marshalling yards and in terminals and an overall increase of the average speed for rail freight operations All innovation activities should also ensure that rail freight is able to better operate in conjunction with passenger traffic in order to maximise the utilisation of the existing network. Furthermore, the freight sector should more build on best practice from the passenger sector and from other modes, in terms of information, planning and monitoring systems.

An essential starting point is a common understanding of the transport chain and the important information flows. Stakeholder needs and restrictions have to be taken into account when defining interfaces and data structures. Besides standard interfaces, which ensure the accessibility of the systems for everybody, dedicated interfaces to existing IT-systems of the stakeholders will be developed to allow integration and full market uptake.

The annual timetable planning is a very important key to an efficient capacity utilisation, stable operations and reduction of disturbances. The continuation of the planning during the year of validity for the time table is called the ad-hoc process. Today, these processes still involve much manual planning and the changes from one timetable to the next are often incremental. Improved decision support tools and analysis tools have shown to have a great potential. Now they should be based more upon real-time information.

The deregulation of the railway market, which is enforced by EU legislation, further puts on new demands for both the infrastructure managers and the railway undertakings related to the utilisation of the railway infrastructure and timetable planning. It is very important and challenging to balance the needs of different types of traffic (freight, high speed passenger, commuter), different and competing RUs and the maintenance operators, and yet to secure a robust railway system with high quality transports.

The train path and slot planning will be improved significantly by newly developed client-tools, which coordinate automatically between the respective planning systems of IMs. This coordination process includes the private network sections like in harbours and also the terminal slots, with the objective to provide a high quality service offer with a reasonably low door-to-door transport time.



The connection and handling of all services in one system, which acts as single access point, will facilitate significantly the usage of multimodal services which include a higher share of rail transport.

The main interaction envisaged, both from the point of view of technologies employed and of interaction in performance and objectives are:

### **Objectives**

The aim of this TD is to develop freight solutions that are highly reliable and flexible, and that enable the optimisation of overall transport time, in particular by increasing the average speed for rail freight operations and by reducing handling and set up times at marshalling yards and in terminals taking into account the new automation technology, but also by ensuring that rail freight is able to better operate in conjunction with passenger traffic in order to maximise the utilisation of the existing network. These solutions should build on best practice from the passenger sector and from other modes, in terms of information, planning and monitoring systems.

Important issues are also a greater performance in *total* dwell time/lead time for the transport and a higher grade of accessibility/connectivity as key factors.

### **Technological output to be delivered by this TD:**

A real-time yard management system  
A real time network management system  
Capacity planning in lines with freight trains better harmonized with passenger trains.

### **Specific achievements to be delivered by this TD:**

1. Improved methods for annual and ad-hoc timetable planning
2. Methods to analyse timetable efficiency and robustness in advance and in follow up process
3. Decision support and automation in timetable planning process (including the management of dangerous goods trains and their interaction with sensible targets along the route)
4. Improved methods handling larger disturbances on the line and in yards and terminals in real time
5. Slot planning/management (cross-border/cross-network)
6. ETA calculation for operation
7. Real-time monitoring of resources availability on yards, nodes and network.
8. A real-time yard management system
9. Standardized data formats / new interfaces in coordination with current TAF/TSI standards
10. Increasing speed of freight trains during day time traffic to increase line capacity
11. Systems for shared usage of marshalling yards between different service providers

The following table shows how the activity proposed will contribute to the achievement of the S<sup>2</sup>R objectives as stated in the S<sup>2</sup>R Master Plan:

**Table 31: S2R objectives addressed in TD5.2 Access and Operation**

S <sup>2</sup> R Objectives	TD Objectives	Practical contribution (how)
Improved services and customer quality	A better real-time traffic management system improves the quality in ETA and overall punctuality which gives better conditions for next part of the chain.	Better systems for real-time monitoring and planning
Reduced system costs	Increased efficiency in the marshalling yards and sidings, reducing lead-time and costs Better line capacity utilisation,	Real time management yard system Improved slot planning.
Enhanced interoperability	Use of open standards and following TAF/TSI standards	Improved cross-border slot planning.
Simplified business processes	Automated connections between RU and IM	Real time management yard and network system

### 5.5.3.2. Technical ambition of Access and Operation

**Table 32: past EU-Projects and their relevance for TD5.2 activities**

Project	Relevance for TD5.3 activities
ON-TIME 2011-2014	The process have been studied at 6 major infrastructure managers and innovations have been demonstrated in methods for timetable planning and decision support for operational traffic control to handle minor perturbations and major traffic disturbances.
CAPACITY4RAIL 2013-2017	The timetable planning methods are further enhanced into a framework with improved methods for timetable planning and operational traffic control.

The main interaction envisaged, both from the point-of-view of technologies employed and of interaction in performance and objectives, includes coordination with other TDs of IP5, namely TD5.1, TD.3, TD 5.4 and TD 5.5, as well as coordination with IP2 (in particular TD 2.9 for ad-hoc timetable planning, methods handling major disturbances, ETA and Slot issues / Definition of methods, concepts and requirements in IP5 and development in IP 2/TD9, such as optimised speed profiles for a DAS), TD 2.2 and TD 2.4 as well as coordination with CCA WA4 Smart Processes

Major technical limitation today is:

- Rail freight hubs is a stand-alone black box within the rail freight supply chain

- The capacity on the lines are limited due to different speed between freight trains and passenger trains.
- Non-effective ad-hoc time-table planning

The following table summarizes how this TD will progress the state-of-the-art and overcome today's limitations and difficulties:

**Table 33: Ambitions and advance beyond state-of-the-art for TD5.2 Access and Operation**

State-of-the-art	New Generation Offer and Operation
Big marshalling yards with many functions are hard to run cost-efficiently and the lead-time is too low.	A Real-time yard management system can optimize resource-allocation and connect with external systems to improve network planning.
On bottleneck railway lines freight trains have to stop very often to let passenger trains overtake.	Faster freight trains can travel longer distances without stop and help to increase line capacity and defend and increase market shares.
The flexibility in ad-hoc planning is low	Improved Ad-hoc time-table planning system meets the freight markets ups and downs.
The IT systems of the network operator and the operators of terminals and yards are often not connected.	The planning of timetables and train paths is done from the beginning to the destination including terminals and yards and the processes inside of them.

In the status quo, yards are a black box for operators and transport customers, due to stand-alone systems for yard planning only. On top of this, rolling stock, personnel and track infrastructure are planned completely separately within historical legacy systems. There is little transparency of planned resources: Neither integrated resource disposition, nor a real-time view, nor overall optimisation of resource allocation is possible. Disposition of assets and personnel is being based exclusively on experience of planners and dispatchers who are still regarding each other as separate functions and not using the same information system.

The future goal of the TD is to incorporate hubs, yards and connecting sidings into capacity-driven order management through optimisation of all relevant resources taking into account new automated handling systems. Provision of real-time data will enable intelligent information design and integration into supply chain management. A transparent mathematically based standard system solution will facilitate partly automated, quick and resource-optimised decision-making in real-time, including perturbation and incident management, in order to achieve on-time delivery according to ETA. Operational information will be shown on handheld devices and displays in locomotives so that everyone in the Yard will have access to information on live resource availability. All of this will become state-of-the-art and will be tested up to TRL 7. There is not a single IT solution available that is capable of any of these aspects.

Within the complexity of the infrastructure and the target system, the vision of the TD Access & Operations is to master the challenging task to develop an overall optimisation tool for yard management in order to adequately steer resources in rail freight yards, hubs and connecting sidings



by introduction of real-time data based decision support systems. Network management system gives decision support for corridors and international networks. Network management interact with yard management. Freight traffic operations planning and operational need to be improved. Freight trains needs to be more punctual a way to achieve that is to develop ad-hoc timetable planning and decision support for operational traffic handling minor perturbations and major disturbances. The goal of the TD is to understand, simulate and optimise disposition decisions and the resulting operational processes in real-time with the help of a powerful decision-support system for yard management and network management, which is able to respond to any scenario including unforeseen incidents e.g. delays of trains, technical failures, new construction requirements. Real-time network and yard management will help to achieve an ideal integration in a European production environment and the capacity-driven order management. This in turn will lead to greater overall reliability of services and Estimated Time of Arrival (ETA) prognosis. It will also streamline the planning and disposition within an application for yard management and network management.

The main lines of the European network have a high traffic load and a mixture of high-speed passenger, commuter and freight trains. Due to their lower speed, freight trains have to stop very often to let passenger trains overpass. This has a negative influence on the efficiency of the heavy freight trains concerning energy consumption and wear. But also the capacity of the lines is affected in a negative way. On the one hand the dynamics of the freight trains cause long acceleration phases, on the other hand the difference in travel speeds produces gaps in the timetable which cannot be used for further traffic. The heavy traffic volume on lines with seaport hinterland traffic generates the danger of the shift of rail-affine transport to the road. An increase of the speed of freight trains during daytime from 120 to 140 km/h could be a solution to this problem. This method is not included in the CAPACITY4RAIL project, because new types of freight wagons are necessary, which is in focus of IP5.

#### ***5.5.3.3. Specific Demonstration activities and contribution to ITDs/SPDs***

In order to provide rail freight transport with the technological means to achieve the business objectives and to address new needs and customer demands, the innovative IT solutions will be specified, designed and developed for improving freight transport stakeholder's coordination with real time data exchange capabilities and enhanced planning tools. This should take advance of existing cutting-edge technological solutions already successfully applied in other transport areas and business sectors (maritime, roads, smart cities, telecom etc.).

System integration based on standardized electronic interfaces is therefore envisaged as one of the most relevant topics to be developed under this R&I area, and therefore, within TD5.2. In a multimodal freight transport environment, the need to integrate and manage a wide variety of different data, from different origins and natures, will require the use of high performance and distributed IT architectures which will be developed in this TD. The central objective is to bring in TD5.2 all relevant and added-value initiatives and ideas related to system integration and interoperability issues coming from related topics especially on IP2 and IP4.

There is the chance of introducing in every wagon a low cost reliable on board unit with IT systems electronics/communication technology in order to maximise the utilisation of the existing network. For that cutting-edge communications systems will be employed, such as RFID, WSN, 5G, etc. for provision of real time data.





The overall concept of real time yard management focusses on the simulation of interdependencies to understand capacity-relevant links on developing a tool that allows orchestrating disposition processes in hubs in real-time. The aim is to improve customer quality and reduce operating cost. For planning and disposition in yards, current IT systems in use administer the relevant resources required to steer trains through these important hubs of the system. In the focus are “Real-time Yard Management” processes in the marshalling yard will be optimised, allocating the existing resources in a yard optimally in real time. The development of the overall optimisation tool and simulation model for yard management, in order to adequately steer resources in rail freight yards, will take into account the new available automated handling systems and the possible different levels of automation. This is the consequent further development of the IT-supported processes using the existing data. It is a two-step approach:

In a first step operations research and accurate modelling in a scalable model for any size and type of hubs, yards and connecting sidings will result in a simulation of resources within existing infrastructure. Dynamic simulation offers the possibility to deeply analyse process flows and find the optimal process scenario through comparative evaluation of simulation runs.

In a second step, based on a stress test of the simulation, software development and testing will start, including the definition of rules, data preparation, processing and interface design, for single stream dynamic planning, disposition and knowledge management. The aim is to produce an IT prototype with HMI interface which can be validated in live demonstration for a selected large and complex hub (TRL 7).

Network management is handled in tactical planning and operational process and is an interaction between infrastructure manager and railway undertakings. For tactical planning the current methods is to simulate and calculate available capacity and optimise the usage of the infrastructure capacity, the framework needs to be further developed. For the operational process decision support needs to be developed to handle minor and major disturbances. To better handle infrastructure maintenance and infrastructure disruptions is another important issue. In IP5 the methods for network management will be further developed especially from the need of freight traffic. To better interact between network management and yard management is an important aspect.

The increase of freight trains during daytime traffic will be evaluated in the first step with operations simulation. Therefore different scenarios are defined to assess the effect of different speed levels and different market penetrations.



**Table 34: Ambitions and advance beyond state-of-the-art for TD5.2 Access and Operation**

Research Area	Specific Technical objectives	Specification Activities	Demonstrator	
			TRL	Focus of activity
Access and Operation	Improved Methods for time table planning	Ready to use basic systems	5	Module based standards for deregulated markets with several actors. Connectivity requirements. Tools based on real time information-
	Real time yard management and Single-wagon load systems	Ready to use basic systems ending with a pilot	7	Integration subsystems with an overall control system tested in a pilot
	Real time network management	Ready to use basic systems	5	Integration subsystems with an overall control system
	Increasing speed of freight trains during day time traffic to increase line capacity	Simulation of scenarios on freight corridors	5	Focus on simulation with time-tabling systems and evaluation.



### 5.5.3.4. Impact of the Access and Operation Demonstrator

#### Technical Impact

**Table 35: Technical Impact of TD5.2 Access and operation**

S2R objectives	Strategic impact
Improved reliability	Enhanced service quality due to improved timetable planning, real time monitoring, increased possibility to automation processes and customer information via tracking & tracing, routing, combining systems of different operators and transport modes, booking procedures, visibility of available services creating quality improvements of 15%.
Enhanced capacity	Improved system utilisation thanks to better train capacity management, shared usage of marshalling yards, and improved knowledge about the maintenance status of wagons will give capacity increase of 15%. Capacity increase of up to 20% on bottleneck lines using faster freight trains during daytime traffic
Customer experience	Integration of rail freight in supply chain management, meaning a great benefit for e.g. automotive or chemical customers who rely on just-in-time delivery. Improved customer experience due to 100% reliable delivery of consignments according to ETA
Lower investment costs	20% improved capacity utilisation of infrastructure, rolling stock and personnel resources in hubs
Reduced operating costs	10% Reduced operating costs due to efficiently optimised single stream disposition decisions. Increased cost efficiency due to improved coordination of the actors in the multimodal chain and improved slot planning and management creating savings/less costs of 10%.
Externalities	
Enhanced interoperability	Standard interfaces and operating instruments connection the whole chain from nodes to different countries through Europe.
Simplified business processes	Automated processes for trains based on real-time data reduces lead-time by 25 % between RU and IM.

**Strategic Impact**

**Table 36: Strategic Impact of TD5.2 Access and Operation**

Strategic Aspect	Key Contribution from the TD
Support the competitiveness of the EU industry	Standardisation and open systems that can be used everywhere in Europe open up for a bigger market than before
Compliance with EU objectives	<ul style="list-style-type: none"> <li>Support to capacity increase: Better planning tools in real time increase the capacity in the lines</li> <li>Greening of transport through reducing the lead time in yards and optimizing loads on trains</li> </ul>
Degree of maturity of the envisaged solutions	Currently most of the proposed technologies are in TRL 1,2 (Principles observed and the possibility of using them formulated) . At the end of Shif2Rail it is expected that the successful concepts are brought to TRL 6 or 7.

**5.5.3.5. Implementation of the work programme**

The approach is to walk through the chain reducing barriers and reducing lead-time by effective real time data and effective planning tools.

**Figure 100: Methodology and approach for TD5.2 Access and Operation**

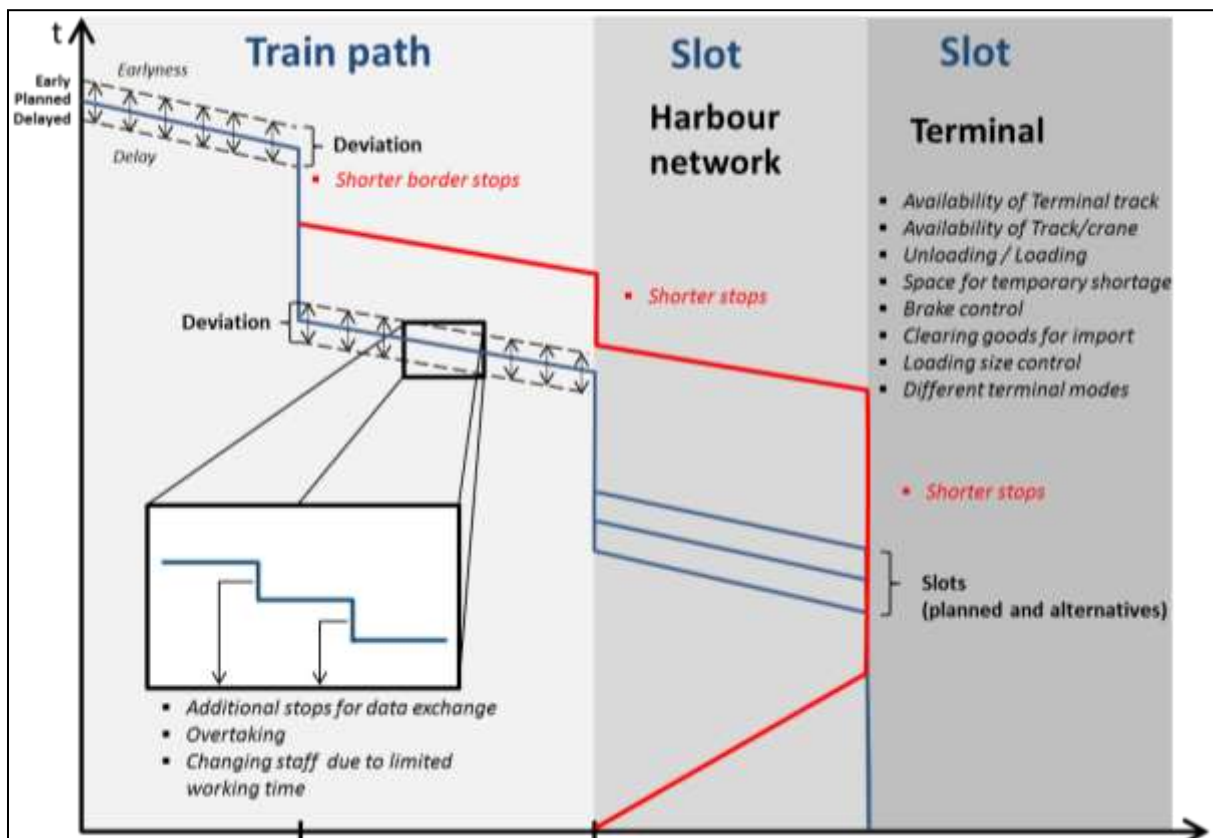



## **Description of Tasks:**

### **Task 5.2.1. Improved Methods for time table planning.**

- Improved methods of time table planning, traffic and maintenance in annual and ad-hoc planning.
- Feedback and forecast methods on performance and decisions based on collected data and advanced data handling methods.
- Methods and KPIs for evaluation of current and future time tables in economic robustness and efficiency aspects.
- Development of processes and incentives for IMs, RUs and maintenance to get socio-economic optimal planning and operation. Better coordination on mixed traffic lines between different train types (freight/passenger).

### **Task 5.2.2 New Single Wagon Load and real time yard management system**

- Analysis of framework conditions (TRL 1), as well as design, validation and development of new basic planning and coordination systems for an open SWL market (TRL 4).
- Deliver requirement specifications and specific system design, interface descriptions, ready to use basic system (TRL 6).

The following six tasks are foreseen to drive the Technology Demonstrator to TRL 3-7, jointly with competent partners for real-time simulation.

- **Pre-Study**

In a pre-study, all necessary operational procedures and the necessary data for simulation are analysed. For the simulation, not only master data e.g. yard infrastructure and shunting fleet, but also dynamic data e.g. fostered personnel resources and actual data of incoming trains are required. Next to the definition of this required data, the relevant architecture guidelines for the current management of local hubs, marshalling yards and connecting sidings are investigated. The variable ETA is considered to be the key measure for active steering of production processes within the yards and an important input factor for the successful simulation of planning.

- **Concept on expert level.**

In the next step a detailed technical proposal is created. All technical necessities and dependencies will be profoundly analysed and specified accordingly. The required interfaces are identified and data fields and respective data formats are defined. Additional required data that is not available at the moment has to be considered in the respective IT systems.

- **Design Specification**

Following the completion and approval of the technical concept, the technical design will describe the implementation of the IT prototype. The technical specifications of the target system have to be recorded and set in relation to one another. The scalable modelling of a selected hub is described in full detail. The technical design is the basis for implementation of the



solution. This incorporates all technical necessities such as adaption of interfaces and extension of data banks, as well as the development of a simulator with capacity for real-time optimisation.

- *Data modelling & Dynamic Simulation*

The next step is to develop the software components and the modelling of data for the real-time simulation. In this phase all components are implemented, the simulation is programmed and the interfaces are designed and extended. At the end of this all components are developed to test them in an integration test.

- *Functional and technical test.*

The test of the solution contains multiple elements. Next to the classical system tests and the validation of the interface, the technical data is checked for completeness and data formats are examined. The simulation is optimised by adjusting of the target system by means of variable methods of modelling. As soon as the respective recommendations for action are evaluated and adequate results are generated, the prototype is integrated into a production-like demonstration environment. In order to do so, after the selection of a specific hub for the pilot, the required data has to be adapted.

- *Pilot*

The pilot operation up to TRL 7 is accompanied by organisational and technical measures and is followed by an evaluation of results. For the entire implementation, profound rail freight know-how and knowledge of the procedures in operation is required and will be provided by the members. The scientific know-how concerning the simulation in real-time and data modelling will be provided by a university with the relevant expertise. The simulation is supposed to contribute to the optimisation of hubs, yards and connecting sidings, so that a technical/ operational steering of all hubs yards and connecting sidings across Europe can be performed based on the same criteria. The processes and resulting operational workflows will lead to an optimisation of transport in rail freight.

### **Task 5.2.3. Real-time Network Management.**

With the centralized information about the traffic conditions (surrounding trains), available infrastructure capacity (maintenance, disruptions), convoy composition and infrastructure characteristics (e.g. real time information about energy in the power supply network or temporary speed restrictions) it is possible to optimize the driving profile of the freight trains and to give advice for the network dispatching system in order to obtain better line utilisation. The system calculates these energy-saving and wear-reducing profiles and the advices for the dispatching system. Communication between traffic control and DAS will be used to improve real time time-table planning for the lines (see TD5.5). Link the functionalities developed in TD2.9 (via integration layer, also developed in TD2.9) to the freight operations. Data exchange platform for inter-modal hub required for connecting freight transport stakeholders; specification of integration layer for yard and network management applications. Conditions for calculating a chain ETA. Requirements and specifications for a shared usage of yards and trains. Moreover, the study of the optimisation of the network management will cover the inter-relationship among the connected hubs and will evaluate the effect that, a technological improvement in a hub, has on the other related hubs, thanks to simulation models

### **Task 5.2.4 Faster and more dynamic freight trains to increase line capacity:**

- *Listing relevant bottleneck lines:*

The first part is to identify relevant bottleneck lines, for which the concept of an increased speed could produce benefit for the line capacity and timetable stability. Some lines are known in advance, these are beside others Malmö – Alvesta, Hamburg – Hannover (part of TEN corridor Scandinavian-Mediterranean), Karlsruhe – Basel (part of TEN corridor Rhine-Alpine), Regensburg – Wels (part of the corridor Rhine – Danube). For selected bottleneck lines, calculate line capacity and describe technical infrastructure capacity.

- *Definition of scenarios:*

The scenarios should be further described about corridor capacity and the benefit of more dynamic freight trains. The speed of fast freight trains (e.g. intermodal trains) is now up to 120 km/h. Speeds of e.g. 140, 150 or 160 km/h should be taken into account. Beside the positive effect of more traction power also the influence on the train capacity (less wagons) due to restrictions of the length of passing loops has to be evaluated. The scenarios should differ in the targeted speed, the train dynamics and the bottleneck line, which is regarded. The speed of fast freight trains (e.g. intermodal trains) is now up to 120 km/h. Speeds of e.g. 140, 150 or 160 km/h should be taken into account

- *Simulation:*

Appropriate simulation tool or tools will be selected. The scenarios needs information about infrastructure, timetable, rolling stock and stochastic disturbances. The questions and parameters to analyse and methodology will be described. The scenarios will be simulated with railway operation simulation tool.

- *Economic assessment:*

The results of the simulation and the necessary adaptations of the freight trains are evaluated. This includes an analysis of all necessary investment and operational costs compared to the cost savings and wider economic effects generated by the faster train operation. This analysis can be done for the different scenarios.

### **5.5.3.6. Planning and budget**

**Figure 101: TD5.2 Access and Operation Gantt chart**

Tasks	Name	2016	2017	2018	2019	2020
TD5.2.1	Improved Methods for time table planning	■	■			
TD5.2.2	Real-time Yard Management	■	■	■	■	■
TD5.2.3	Real-time Network Management		■	■	■	■
TD5.2.4	Increasing speed of freight trains during day time traffic to increase line capacity	■	■			

The estimated budget for the TD is around 9.6 M€.



#### 5.5.4. TD5.3 Wagon design

##### ***5.5.4.1. Concept and objectives of the Wagon design Demonstrator***

Highly productive freight trains will dramatically contribute to the modal shift from road to rail transport. In order to obtain a significant shift of freight transportation from road to rail in Europe – and reduce greenhouse gases -rail transport has to be cheaper, faster and better. Therefore, it is necessary to have high quality paths that enable a high level of punctuality and reliability for rolling stock with a proactive maintenance.

A new efficient wagon design with better performance for different categories of freight will be achieved leading to a step change within Shift2Rail. A better payload per meter of train is one of the key efficiency factors, as is getting a greater volume per meter of train, particularly for light density freight. High performance freight wagons lead to massive improvements in the rail network capacity as they allow freight traffic to follow passenger traffic flows throughout the network. It also means that rail freight transport can be distributed to all parts of Europe, from locations in central Europe within 24 hours. A faster transport in the rail sector also means a cheaper transport cost for the freight. The high speed freight wagons will be designed for a maximum speed of 120 – 160 km/h whilst resulting in less wheel and track damage and wear. The freight wagons are highly productive and have a modular concept with combination possibilities to create different standard solutions for individual transport needs and allow for rail freight automation due to integration of electrification, telematics and automatic coupling concepts. Due to low noise solutions 24/7 freight operation will be possible and the energy consumption will be reduced significantly thanks to lowest aerodynamic resistance.



**Figure 102: Concept of Wagon design technology demonstrator**

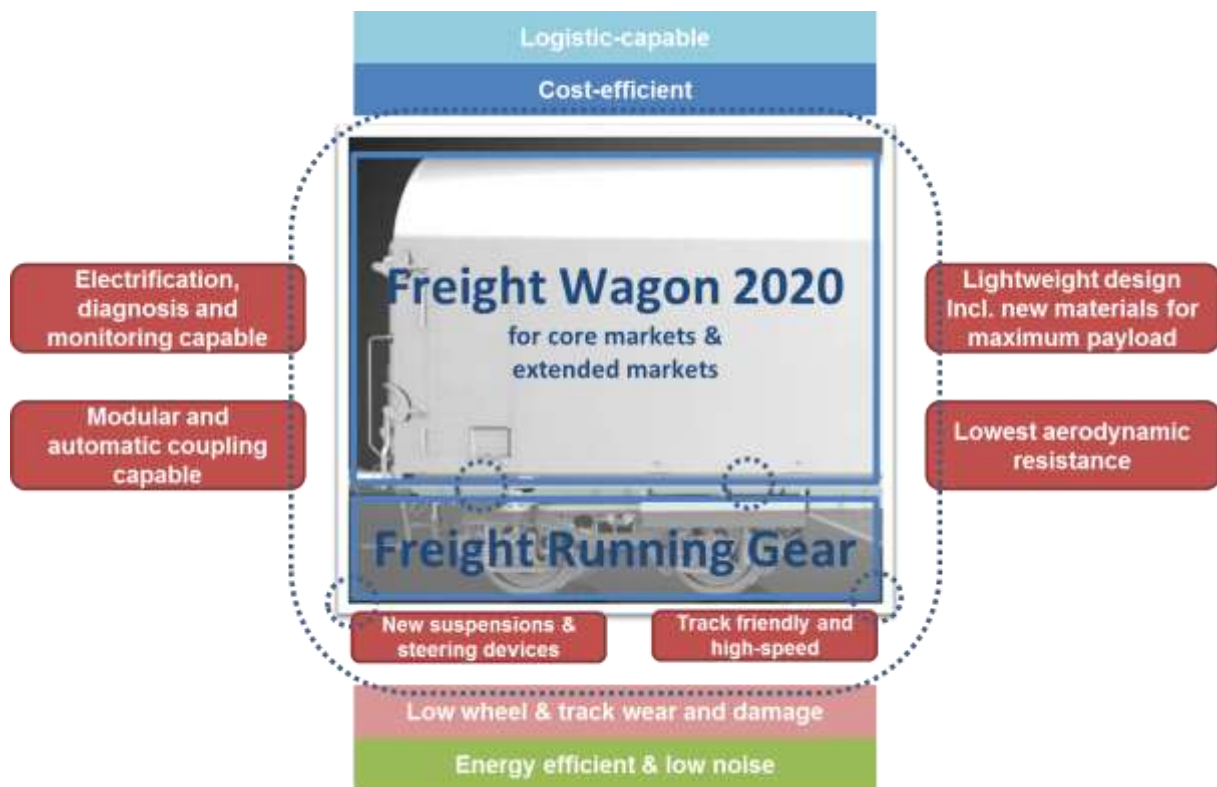

Thus, the aim of this TD is to produce technical demonstrations of the next generation of freight bogie and freight wagon in order to prove its competitiveness and to show that a rail freight option is equal to the freight market demands of the year 2020.

Based on market needs and business cases for rail freight a common approach will be used to develop competitive freight wagon concepts. A new low noise, track friendly, high speed Freight Running Gear with modular interfaces to different wagon designs will serve as the basis for the development and demonstration of the *Freight Wagon 2020* for core and extended markets.

The *Freight Wagon 2020 body for core markets* will defend, regain and increase the market share in traditional rail freight transport markets. In this context state of the art technologies in wagon design will be improved significantly (e.g. reduction of weight by using high strength steels in bogie and carbody design, improved passive suspensions and wheelset steering technologies for higher speeds and track friendliness, capability for advanced diagnosis and monitoring functionalities for increased customer experience and reliability).

The *Freight Wagon 2020 body for extended markets* aim to increase existing and expand future new market share for cargo transport by application of new technologies beyond state of the art (e.g. reducing weight by using low cost composite materials in the body & chassis design, aerodynamic and acoustic fairing for lower energy consumption and lower noise, system integration to supply intelligence on board for i.e. reefer transports). It will consist of a common chassis with different top units addressing container, groupage and combined intermodal transport needs respectively. A successful opening of market segments which will be identified in TD 5.0.

**Technological output to be delivered by this TD:**

Low-noise, lightweight, high speed & track friendly Freight Running Gear  
Freight Wagon 2020 – for core market share increase & extended markets

The following table shows how the activity proposed will contribute to the achievement of the S2R objectives as stated in the S2R Master Plan:

**Table 37: S2R objectives addressed in TD5.3 Wagon design**

S <sup>2</sup> R Objectives	TD Objectives	Practical contribution (how)
Improved services and customer quality	Increased reliability and improved capacity	Modular lightweight freight wagon design with increased payload and platform wagon frame. Wheel- and track-friendly running gears for higher speed and low-noise with interfaces to vehicle & goods status monitoring and localisation based on new value-added service features, such as electric power supply/connection and automation due to automatic coupling (see TD5.1)
Reduced system costs	ROI increase, reduction of operating and maintenance costs, reduction of externalities	Aerodynamically optimised lightweight freight wagon design for increased energy efficiency with monitoring functionalities for predictive maintenance strategies based on widely accepted economic assessment method. Noise reduction and wheel- and track friendly running gears for lowest wear and tear. Larger volume/higher payload improves utilisation of the wagon, resulting in the relative reduction in needed number of vehicles of given capacity
Enhanced interoperability	Enhanced interoperability	Increased standardisation of wagon frames and running gear for different segment together with vehicle & goods status and localisation
Simplified business processes	Improved approval process, reduced design verification and testing effort	virtual development and certification, multidisciplinary optimisation



#### **5.5.4.2. Technical ambition of the Wagon design Demonstrator**

##### **Existing major technical limitations, blocking points**

A significant share of the issues addressed in IP5 is due to the limitations in wagon technology, and these limitations lead to uncompetitive offerings to the logistic market and a “frozen” business structure in the rail freight business. The potential provided by state-of-the-art locomotive technology (interoperability and efficiency) cannot fully be exploited as long as the following limiting factors on freight wagons remain:

- Unsatisfying train dynamics due to standard couplers, poor manually controlled braking systems (UIC standard) and lower speeds compared to passenger traffic prevent exploiting the remaining capacity of the network in daily hours while introducing high damage to the infrastructure.
- Payload-deadweight ratios are poor, especially in the most emerging market segments of containerized single goods transports
- Low energy efficiency due to poor aerodynamics and high noise levels due to legacy technology in suspension and braking.
- Missing electrification of freight wagons limits the market access as attractive market segments like temperature controlled transports (reefer market) cannot be served and the digital integration in the leading logistic process is not possible (electronic freight orders and tracking – specially for dangerous goods) (integration of TD5.1 results)

The next generation of freight wagons will only complement the TSI standards for freight wagons with speeds of 120 – 160 km/h. All design will comply with TSI Telematics applications for freight service, rolling stock freight wagons, operational and traffic management, infrastructure, energy, control command, signalling and noise. With the modular design of bogie and wagons it is possible to cover most of the transport needs.



The next generation of freight wagon will incorporate all the best developments by the European Commission from the following projects:

**Table 38: past EU-Projects and their relevance for TD5.3 activities**

Project	Relevance for TD5.3 activities
FASTRCARGO (2006 – 2009)	The principals of a new way to shift containers between road and rail were presented
NEWOPERA (2005 – 2008)	Rail freight as an effective alternative for road transport where a business model was reviewed
RETRACK (2007 – 2011)	Subproject Mod
VELWAGON (2010 – 2012)	Longer and lighter wagons with fewer axles
SUSTRAIL (2011 – 2015)	The correlation between vehicle and track design
SPECTRUM (2011 – 2015)	Freight train that behaves like a passenger train in terms of speed, acceleration, braking and has a standardized universal power supply system
E-FREIGHT (2010 – 2013)	Support system for transport users, transport service providers, transport infrastructure providers and transport regulators
MARATHON (2011-2014)	Increase in train length, speed and weight on constrained rail infrastructure

The main interaction envisaged, both from the point-of-view of technologies employed and of interaction in performance and objectives, are:

- IP5 – TD5.0 “Implementation strategy and business analytics
- IP5 – TD5.1 “Freight Electrification, Brake and Telematics”
- IP5 – TD5.4 “Novel terminals, hubs, sidings and marshalling yards”
- IP5 – TD5.5 “High Performance Freight Train”
- IP1 – TD1.4 “Running Gear”
- IP3 – Infrastructure (TD3.1 – TD3.4. criteria and models for the assessment of track friendliness, TD3.6 – TD3.7 measuring, monitoring and maintenance)

#### **Shift2Rail Vision of the wagon design TD**

The vision for the wagon design TD proposed in S2R is based on the expected evolution of fundamental technologies within the following focus areas:

- Track friendly, low weight, high speed Running Gear (in order to be as flexible as possible for Wagon Designs 2020, but also for other wagon topologies) – *Running Gear*
- Wagon Design 2020, modifications for core markets- *Core Market Wagon 2020*

- Wagon Design2020, for increased share and new market segments – *Extended Market Wagon 2020*

The following table summarizes how this TD will progress the state-of-the-art and overcome today's limitations and difficulties:

**Table 39: Ambitions and advance beyond state-of-the-art for TD5.3 Wagon design**

State-of-the-art	Ambitions and expected advance beyond state-of-the-art
Modular lightweight wagon design still underexploited	Comprehensive lightweight design, including structural optimisation, functional lightweight and smart material selection & substitution (including fibre-reinforced plastics), will result in energy savings and higher capacity (payloads)
High sound pressure level	Multidisciplinary optimised <i>very quiet</i> wagons (according to TSI limits) comparable to passenger train limit (70 dB(A))
Expensive series of on-track noise tests are required to achieve standard limits.	Reliable noise emission prediction significantly reduces on-track testing
Wagon design not aerodynamically optimised	Validated advanced aerodynamic drag reduction concepts
Running gears not optimised regarding higher speeds, curving resistance, noise, wheel-rail and track degradation	Wheel and track-friendly running gears with improved wheel-rail guiding for higher speeds
Application of reactive maintenance strategies	Condition based maintenance based on Wagon monitoring systems
Wagons designed to comply with minimum level of relevant standards	Optimised wagon design by applying multidisciplinary methods (e.g. noise, aerodynamics, wheel-rail interface, LCC)

### 5.5.4.3. Specific Demonstration activities and contribution to ITDs/SPDs

The overall S2R goals will be addressed by the three focus areas (i.e. demonstrators) summarized in the table below:

**Table 40: contribution of TD 5.3 Wagon Design to the different ITDs**

TD	Focus Areas	Demonstrator		Demonstrator
		Market	TRL	
Wagon Design	Running Gear	Freight	5-7	A track friendly, low weight, low noise high speed <b>Running Gear</b> capable to run under standard wagon bodies and the freight wagons 2020 will be demonstrated <b>in hardware in relevant environment</b> in a freight train including the technologies from TD5.1 (electrification, ...)
	Core Market Wagon 2020	Freight	5-6	Modular, logistic capable and cost-efficient, low weight, payload and aerodynamic optimised <b>Freight Wagons 2020 for Core and Extended Markets</b> will be demonstrated together <b>in hardware in relevant environment</b> including technologies form TD5.1 (electrification, diagnosis and monitoring, telematics and communication and automatic coupling) in a freight train
	Extended Market Wagon 2020	Freight	5-6	

Together with the technologies developed in TD5.1 (Electrification, vehicle and goods status monitoring, localisation, automatic coupling, end-of-train device and wireless communication between wagons and to locomotive and infrastructure the innovative and competitive wagons 2020 will be integrated in a freight train ITD demonstrating the intelligent freight train of the future.

#### 5.5.4.4. Impact of the Wagon design Demonstrator

The following tables summarises the impact contributions of TD 5.3 Wagon Design to the S2R objectives with respect to technical and strategic aspects:

#### Technical Impact

**Table 41: Technical Impact of TD5.3**

S2R objectives	Strategic impact
Improved reliability	Freight vehicle reliability <b>increase of 5%</b> due to <b>freight wagons</b> with high speed, wheel and track-friendly running gears and vehicle & goods monitoring systems, ensuring safe operation and protecting vehicles and goods.
Enhanced capacity	<b>Lightweight freight wagons</b> with <b>10% more payload</b> and running gear weights down to <b>4300 kg</b> .
Customer experience	<b>Freight wagons</b> that provide vehicle & goods status monitoring as well as localisation, will increase service quality <b>for vehicle operators, logistics providers and customers</b> .
Lower investment costs	<b>ROI increase of 15%</b> due to higher payload and more flexible <b>freight wagons</b> approved by widely accepted <b>economic assessment method</b> .
Reduced operating costs	Lightweight, track-friendly, aerodynamically improved freight wagons with monitoring functionalities and <b>predictive maintenance strategies will reduce LCC for vehicles by 30%</b> and reduce <b>track maintenance costs</b> . Furthermore rail freight automation due to automatic coupling will significantly reduce operating costs.
Externalities	The pass-by <b>noise</b> will be reduced to the passenger train limit (70 dB(A)), and <b>environmental impacts</b> will decrease due to lower weight, running gears with lower curving resistance and aerodynamic optimisation.
Enhanced interoperability	Newly developed technologies will contribute to <b>standards</b> (e.g. TSI WAG, TSI TAF). Vehicle & goods status data usage will yield higher <b>operational interoperability</b> .
Simplified business processes	The time for <b>approval process</b> will be reduced by <b>20%</b> due to virtual certification. <b>Virtual development</b> will reduce the required testing efforts and reduce the <b>design verification</b> period by <b>20%</b> .



## Strategic Impact

**Table 42: Strategic Impact of TD5.3**

Strategic Aspect	Key Contribution from the TD
<i>Support the competitiveness of the EU industry</i>	<ul style="list-style-type: none"> <li>• Technological leadership supported by a combination of radical innovation (e.g. high-speed, aerodynamically optimised, low-noise, lightweight, logistics-capable, LCC-oriented freight bogie and wagons and the integration of high strength steels &amp; fibre-reinforced plastics) setting an effective advantage for the European industry</li> <li>• Tangible benefits for the end user:               <ul style="list-style-type: none"> <li>○ Higher payload, increased flexibility and integration into data driven logistics processes together with automated coupling</li> <li>○ Support capacity increase because of increased speed of freight wagons</li> <li>○ LCC reduction due to technology development with integrated LCC optimisation and virtual certification</li> </ul> </li> </ul>
<i>Compliance with EU objectives</i>	<ul style="list-style-type: none"> <li>• Promotion of modal shift: A big impact brought by the implementation of these new technologies by demonstrating the economic benefits of new bogie and wagon designs including improved logistics due to automation making rail freight more attractive</li> <li>• Support to capacity increase: as mentioned above this is allowed by higher speeds for rail freight and increased payload</li> <li>• Greening of transport through energy reduction and lower noise can be achieved by better integration of track-friendly running gear, aerodynamic optimisation and noise measures in the overall freight wagon concept</li> </ul>
<i>Degree of maturity of the envisaged solutions</i>	<ul style="list-style-type: none"> <li>• Currently most of the proposed technologies are in TRL 1, 2 (Principles observed and the possibility of using them formulated). At the end of S2R it is expected that the successful concepts are brought to TRL 6 to 7.</li> </ul>



#### 5.5.4.5. Implementation of the work programme

In order to guarantee that the desired final objectives are met a clear methodology has been devised for the organisation of the technical work in this TD. This is represented in the following schematic representation:

**Figure 103: Work breakdown scheme (tasks) for TD5.3 Wagon design**



#### Description of Tasks:

##### Task 5.3.0. Scanning of Innovations (TRL 1-2):

The objective of this task is to find new design and new production methods, as well as alternative materials for wagon design 2020.

The contribution of the S2R members will cover the following:

- Analysis of the state of the art and definition of specifications focusing on wheelset components as well as specifications for industrial module production. Review and definition of functions and requirements for multi-disciplinary optimisation of freight wagon structures
- Definition of requirements based on priorities, benefits and business cases including those for economically affordable for low-noise / low friction bogie
- Identification of missing technologies required for next generation freight wagons
- Identification necessary research activities
- Adaptation of experimental and numerical methods to needs of freight train aerodynamics. Scanning for potential energy savings by drag reduction at different scenarios (max. speed, wagon fleet etc.)



### **Task 5.3.1 Wagon design (up to TRL 3):**

The objective of this task will be to define the general specifications for a multi-purpose next generation freight wagon 2020 and carry out the development of the freight wagon 2020. Specific requirements including necessary research activities have to be determined and a cost benefit analysis (CBA) of the advantages of a modular concept investigated (see TD 5.0).

The contribution of the S2R members will cover the following:

- Specification of components/subsystems
- Development of components, subsystems and overall system for the Freight Wagon 2020:
  - Modular lightweight design
  - Integration of vehicle & goods monitoring systems
  - Aerodynamic design
  - Noise reduction
- Multidisciplinary optimisation of components, subsystems and overall system with respect to strength, aerodynamics, vehicle dynamics, N&V, wheel-rail degradation, energy efficiency, etc.

Open calls are foreseen for the areas of structural analysis, material selection, repair procedures for lightweight materials

### **Task 5.3.2 Running gear (up to TRL 3):**

The objective of this task will be to develop a bogie for the next generation of freight wagons 2020, with excellent dynamic protection from track alignment and from wagon forces created by the dynamic movements of the vehicle.

The contribution of the S2R members will cover the following:

- Specify components/subsystems according
- Develop components, subsystems and overall system for flexible use in current wagons as well as the Freight Wagon 2020
  - Lightweight design
  - Wheel, track and curving-friendly running gear
  - Integration of brake systems
  - Integration of vehicle monitoring systems, predictive maintenance strategies
  - Noise reduction



- Multidisciplinary optimisation of components, subsystems and overall system with respect to strength, aerodynamics, vehicle dynamics, N&V, wheel-rail degradations, energy efficiency, etc. together with an Integrated assessment of freight economics (see TD 5.0)

In TD5.3 a new low-noise, track-friendly running gear for the year 2020 will be developed, including an appropriate low noise braking system which will focus on cost effective noise reduction and reduced LCC. Research in this area will aim at the improvement of existing braking technologies (and their LCC) with a particular focus on the effect for noise reduction.

#### **Task 5.3.3 Definition of components and running gear and wagon manufacturing (up to TRL 4):**

The objective of this task will be to define and manufacture all components of the bogie and the wagons 2020 and finally to assemble the wagons 2020. All components have to be tested in collaboration with each other to ensure full functionality and to create trials for environment tests (i.e. dangerous goods), safety tests and scope for construction; static and dynamic tests, material testing, fatigue tests, testing of monitoring functionalities, testing of braking system, the validation of aerodynamic design using wind tunnel tests and numerical and lab testing on system level: safety against derailment, strength, crash, braking, noise, etc.

The contribution of the S2R members will cover the following:

- Manufacturing (components up to bogies and full wagons). Design of the new generation wagon through the development of the wheelset components to be integrated in the wagon and integration of automatic couplers. Manufacturing and testing of components Implementation of freight electrification solutions. Smart material selection and implementation. Support Suspension & Break System Integration. New braking control strategies. Test components in collaboration with each other. Specification of aerodynamic measures for chassis and top units. Safety relevant aerodynamics. Wind tunnel test campaigns. Integration of fairings in structural lightweight components, measures on underfloor area, lateral contour and intercar gap.
- Testing of components, subsystems and overall system in lab, static and dynamic tests, material testing, fatigue tests, testing of monitoring functionalities, testing of braking system
- Testing on system level: design of test plans, test runs, safety and security analyses and evaluations of results, safety against derailment, strength, crash, braking, noise, etc.

Open calls are foreseen for the areas of manufacturing and integration of specific components and subsystems, e.g. suspension elements, bearings, brakes, etc.

#### **Task 5.3.4 Complete freight wagon demonstrator Implementation (up to TRL 5-7):**

The objective of this task will be to analyse and define the demonstration of freight wagons 2020 for validation and cross-acceptance within the EU including technical solution(s). The solutions developed in TD5.1 will be integrated in wagons 2020. A focus will be put on improved calculation methods for certification and on better utilisation of rail loading gauges and demonstration of loading gauge-related safety margins. The task comprises integration and validation tests (TRL 5) as well as implementation in relevant environment (TRL 6) with the goal of demonstration in operational environment (TRL7).

The contribution of the S2R members will cover the following:

- Application of wheelset components (wheels and axles) for the implementation and participation on the integration and validation tests. Integration of automatic couplers into the wagon demonstrator
- Supply of running gear and Core Market wagon 2020 for the implementation and participation on the integration and validation tests
- Acoustic validation by means of microphone array measurements & drag validation by means of on board measurements
- Validation and cross acceptance
- Implementation & integration of demonstrator

**Task 5.3.5 Feasibility Study on business impact of semi-autonomous movement of single wagons in sidings**

Single wagon load business to be reactivated or strengthen requires efficient operations in sidings as the last mile absorbs the biggest portion of the total transport costs referring to the wagon or to a small group of wagons. The study will focus on a self-propelled wagon that can be operated via remote control between network and destination in the sidings, its cost and its potential impact to gain market share. Constrains of the signalling system and operational rules have to be looked on.

The contribution of the S2R members will cover the following:

- Analyses of the outcome of past projects on autonomous and self-propelled wagons.
- Impact analysis of the operational advantages in sidings, marshalling yards and hubs.
- Cost estimation of wagon and operations.
- Development of the Implementation Strategies and Business Analytics for autonomous movement of wagons

**5.5.4.6. Planning and budget**

**Figure 104: TD5.3 Wagon design Gantt chart**

TASK		TRL	2016	2017	2018	2019	2020	2021
<b>TD5.3</b>	<b>Wagon Design</b>							
5.3.0	Scanning of innovations	1	■					
5.3.1	Wagon design	4	■					
5.3.2	Running gear	4	■					
5.3.3	Definition of components and running gear and wagon manufacturing	4			■			
5.3.4	Complete freight wagon demonstrator implementation	5-6				■		



The estimated budget for the TD is around 10.1 M€.

### **5.5.5. TD 5.4 Novel Terminal, Hubs, Marshalling Yards, Sidings**

#### ***5.5.5.1. Concept and objectives of TD 5.4***

Two separate activities are foreseen in response to the Master Plan aspects of TD 5.4 “Novel Terminal, Hubs, Marshalling Yards, Sidings”. The focus will be on a) novel terminals for improved data gathering, steering, operation and coordination of intermodal transport with a terminal design that allows efficient change of transport modes and b) the hybridisation of the legacy shunting fleet operating in marshalling yards and sidings by means of retrofitting.

Namely, two Technology Demonstrators in the focus areas are foreseen:

- “Intelligent Video Gate Terminal” (TD 5.4.1) and
- “Hybridisation of Legacy Shunting Fleet” (TD 5.4.2)

The intermodal segment relies mainly on the use of containers and semi-trailer trains. The growth of intermodal transport is one of the critical success factors for shifting cargo from road to rail. Today terminal infrastructure operates in peak times at the limit of its capacity. Despite the implementation of several yard management systems there are a lot of physical checks and manual data collection necessary. With the Novel Terminal Design and Operation, the intention is to initiate the next logical step to a higher degree of automation of terminals. Reliability, service characteristics and cost competitiveness in this segment can progress significantly with the optimisation of terminal design and operations – e.g. through improved information transported and better data exchange between involved parties along the intermodal transport chain. The Novel Terminal will focus on train in- and outbound detection, documentation and transfer of wagon and on Intermodal Loading Units (ILU) data.

Besides intermodal terminals, in order to achieve the goals of Shift2Rail and the EU White Paper on Transport, single wagonload traffic is of paramount importance. This results in an additional focus on marshalling yards and sidings where shunting locomotives are a critical part of the value chain. To quickly react to competitive pressure from road, particularly for single wagonloads, and to defend rail freight’s position as most ecological freight mode, Hybridisation of the Legacy Shunting Fleet is most substantial. In order to have quick market impact, the real challenge is to make hybridisation ready for refit of the aging yet reliable fleet to significantly lower the lifecycle cost, quickly improve externalities and achieve greater flexibility of operators for the benefit of customers.

As basis for retrofitting, a Diesel-electric base is preferable because the motor-generator unit can be easily adapted. The hybridisation should take place in Eastern Europe, where Diesel-electric engines are dominant. Besides the development of the hybrid refit kit, in collaboration with TD 5.5 the TD will generate important re-engineering know-how.

**Technological output to be delivered by this TD:****“Intelligent Video Gate Terminal” (TD 5.4.1):**

By 2020, the intention is to optimize a fully operational terminal with an intelligent video gate and data management to enable fast and reliable detection of incoming and outgoing assets.

**“Hybridisation of Legacy Shunting Fleet” (TD 5.4.2):**

By 2020, the intention is to refit an existing European Diesel shunting locomotive class to test two hybrid prototypes for an energy-efficient and environmentally friendly second life.

**Specific achievements to be delivered by this TD:**

1. Optimize operational processes and utilisation of the capacity of intermodal terminals with intelligent video gate systems as used elsewhere in logistics, in order to automatically detect the wagon number and intermodal loading units (ILU) handled, as well as visible damages. In addition a terminal design that allows efficient dwell times and handling is a prerequisite.
2. Retrofitting of an aging heavy European Diesel Shunting locomotive class with a new engine, introducing a container concept with powerful Li-Ion traction battery for cost-efficient and therefore easily marketable hybridisation

The following table shows how the activity proposed will contribute to the achievement of the S<sup>2</sup>R objectives as stated in the S<sup>2</sup>R Master Plan:

**Table 43: S2R objectives addressed in TD5.4**

S <sup>2</sup> R Objectives	TD Objectives	Practical contribution (how)
Improved services and customer quality	Improved reliability Enhanced capacity Customer experience	Dwell times and handling times in intermodal terminals are reduced, reliable throughput is maximized, enhancing intermodal capacity Improved offer of emission free transport to customers, with battery powered hybrid shunters, enhancing customer experience at delivery
Reduced system costs	Lower investments costs Reduced operating costs	Refit of terminals with video technology avoids costly manual data handling for incoming and outgoing wagons and ILUs Cost-efficient second lifecycle of a locomotive using the given frame, platform and bogie leads to 20% reduction of Diesel consumption and 10% reduction of LCC cost
Enhanced interoperability	Externalities	Refit of shunters will reduce energy consumption by 20%
Simplified business processes	Simplified certification and authorisation	Hybrid shunter to be authorised in various European countries

#### **5.5.5.2. Technical ambition of TD 5.4**

In order to make rail transport more competitive, intermodal operations in terminal must be enhanced significantly, since today between 10% and 50% of the transport time is spent as “passive/dwell time” [2012 BOYSEN]. This is one of the most important barriers to increasing productivity. Terminal and rail freight operators and the transport industry at large are fully aware of this situation, and several European initiatives and studies have been launched to tackle this issue, the most important ones are highlighted in the table below.

It is noteworthy that at present in Europe much effort is aimed at increasing the bundling of freight flows and the use of new generation terminals, which will mean an increase in the use of handling operations of freight terminals. An increase in handling can only be justified by a considerable increase in the performance of the current terminals, a decrease in cost, or a combination of the two foregoing developments. The aim of the TD5.4 is to elaborate upon the potentiality of new generation freight terminals capable to improve and overcome the following barriers/performances:

- Terminals passive node time (mainly shunting to/from terminals) are on medium distances up to 30 % of the total transit time
- Loading and unloading time of load units is 3-5 minutes per unit. Hence the turnaround time at a begin and end terminal is 4-5 hours



- Terminals based on vertical transshipment, with dedicated terminal staff
- The terminals design are based on the past loco standard

Based on these insights the main objectives of “Novel Terminal Design and Operation” (TD 5.4 1) are:

- replacement of manual physical checks and manual data collection
- acceleration of the terminal operation process, reduction of dwell times for trains, trucks and ILU
- management of train set-up procedures at terminal providing tools to save actives in use
- increase of handling capacity, improvement of supply chain safety and security
- extension of rail-related services for ILU, rolling stock and train/ILU-related data processing
- improve interoperability and increase attractiveness of intermodal transport
- enhance data exchange between terminals

Looking at the objectives of lower investments costs and reduced operating costs and externalities for sustainable and attractive European freight, a second focus area has been defined to achieve the retrofitting of the shunting fleet with hybrid engines. The shunting fleet operating in marshalling yards and servicing customer sidings will be critical to achieve cost-efficient growth of the European block train and single wagon load markets and to service customer sidings at environmentally friendly conditions and affordable rates. Here the following challenge is faced:

With regards to product lifecycles, shunting locomotives are among the oldest asset in the rolling stock of freight operators. The average age is 49 years and 69% of the shunting locomotives are older than the critical age of 50 years. At the same time, the competitive situation and the current margins in rail freight do not allow operators to invest in the development of new, eco-friendly shunting technology. Therefore, shunters are usually re-motorized with conventional Diesel engines off the shelf.

While economical motives lead to the re-motorisation in many cases, the ultimate goal from both an economical and an ecological perspective would be to refit the shunting locomotives with a hybrid traction battery for emission reduction and energy recuperation. The development and introduction of a hybrid refit kit will have a great impact on the cost structure of marshalling yards and sidings and therefore shunting services in train composition and wagon delivery. An ideal base locomotive class will be operating in multiple marshalling yards, in relevant future markets, have proven as robust and reliable over time and offer constructive weight reserve for a powerful and currently still heavy battery pack.

Based on this prerequisites, the main objective of “Hybridisation of Legacy Shunting Fleet” (TD 5.4 2) will be

- development of a hybrid concept for given load cycles
- inclusion of a battery pack with traction force similar or equal to that of the Diesel engine



- using the battery as main traction source, and for energy recuperation
- allowing supply power of the battery as a booster, allowing a more efficient re-dimensioning of the combustion engine for the same total output and having higher flexibility in usage of the shunting locomotives
- development of hybrid change & modularisation concept, e.g. with a container concept

**Table 44: past EU-Projects and their relevance for TD5.4 activities**

Project	Relevance for TD5.4 activities
FP7-BESTFACT – 2012-2015	It is worth mentioning that this EU-funded project aims at translating the best practices of the lean factory to multimodal freight transport. However, in the context of this project, rail transport is not considered in detail and innovative solutions meeting specific rail transport requirements are not provided.
FP7-TIGER-2009-2012	“Transit via Innovative Gateway concepts solving European intermodal Rail needs”. The aim of this project was the definition of the necessary steps to provide a solution to congestion of roads and ports in the EU. The outcomes of the project are really interesting from the point of view of modelling a supply chain. However, the innovative ICT solutions to be provided to the terminals and rail freight wagons were not addressed.

The main interaction envisaged, both from the point-of-view of technologies employed and of interaction in performance and objectives, are:

- IP5 – TD5.0 Co-ordination with market research
- IP5 – TD5.1 Co-ordination with focus area “Condition-based Maintenance”
- IP5 – TD5.2 Co-ordination with focus area “Real-time Yard Management”
- IP5 – TD5.3 Co-ordination with focus area “Freight Wagon 2020”
- IP5 – TD5.5 Co-ordination with focus area “Full electric last mile”

#### **Shift2Rail Vision of TD 5.4**

The vision for TD 5.4 with the focus areas “Intelligent Video Gate Terminal” (TD 5.4.1) and the “Hybridisation of Legacy Shunting Fleet” (TD 5.4.2) is part of the overall vision for IP5 described also in the introductory pages:

- Digitalisation and automation will boost rail freight productivity and punctuality, creating competitive cost structures and stimulating growth in Europe by providing more efficient, reliable and high-quality rail freight services
- Intelligent video technology in transshipment terminals will raise the quality of rail freight services, improve staff productivity and resource utilisation and increase infrastructure capacity along with further automation of operations

- Advanced propulsion technologies including the hybridisation of legacy fleets will significantly reduce energy consumption and emissions, strengthening rail freight competitiveness while lowering the carbon footprint, and all of that in the very short-term
- Hybridisation of the legacy fleet will make it possible to offer improved “green” services to customers as an important contribution to implement strengthen rail freight’s status as most sustainable, cost- and eco-efficient transport mode across Europe
- The development of flexible solutions such as a hybrid kit and a container/modularisation concept for facilitated engine exchange will help to respond to the challenge of road freight productivity and enable sustainable growth in freight traffic along key European corridors

The following table summarizes how this TD will progress the state-of-the-art and overcome today’s limitations and difficulties:

**Table 45: Ambitions and advance beyond state-of-the-art for TD5.4**

State-of-the-art	Ambitions and expected advance beyond state-of-the-art
Intermodal terminals are not making use of the potential of digitalisation. They are not equipped with visual or sensing technology for detection of wagons and ILUs, signs and of damages.	Intermodal terminals will be equipped with video gates for automated detection of incoming and outgoing wagons and ILUs, signs and of damages to clarify claims situations.
Terminal operators and railway undertakings exchange data on wagon and ILUs in varying formats, leading to unnecessary manual work.	The process of data management in intermodal transshipment will be standardized, based on automated data exchange and transaction. Established standard communication between terminals based on TAF TSI messages.
New hybrid locomotive are available in light to medium power class. No refit solutions with powerful traction battery (equal to traction force of Diesel engine) are available for hybridisation of the shunting fleet.	Hybrid kits with powerful traction battery will be available for the refit of the aging yet reliable shunting fleet in the nodes of the rail freight system, making it possible to run the majority of time on electric energy
As of date, Li-Ion batteries are not used as traction batteries in rail propulsion concepts, due to safety concerns and the lack of standards	A standard for the safe introduction of operational handling of Li-Ion batteries in rail freight shunting locomotives will be developed

### 5.5.5.3. Specific Demonstration activities and contribution to ITDs/SPDs

**Table 46: Ambitions and advance beyond state-of-the-art for TD5.4**

Research Area	Specific Techn. objective	Specification Activities	Demonstrator	Focus of activity
			TRL	
Novel Terminal, Hubs, Marshalling Yards, Sidings	Intelligent Video Gate Terminal (TD 5.4.1)	Specification of terminal design transshipment processes in terminals equipped with intelligent video gate and information management	7	Based on a typical terminal along a European corridor, develop a solution for reduction of dwell time and improved handling of wagons and intermodal loading units using intelligent video gate technology
	Hybridisation of Legacy Shunting Fleet (TD 5.4.2)	Specification of running gear, frame, cab, hybrid propulsion system and safety system for the retrofit of shunting locomotives	7	Based on a reliable shunting locomotive platform Replace the existing Diesel engine with a hybrid propulsion system consisting of an equally powerful combustion engine and traction battery

### 5.5.5.4. Impact of the Demonstrator

#### Technical Impact

Following impacts will result from the demonstrator of an **Intelligent Video Gate (IVG) Terminal in 5.4.1:**

1. automated data collection, validation with pre-defined transport data and improvement of data quality
2. acceleration of in-/outbound train documentation
3. information to users about critical deviations of data, wagon and ILU codes, placards of dangerous goods
4. reduction of time required for checks on a train of 700 m length from approx. 40 min to ~ 15 min
5. ILU and wagons are faster available for the follow up transshipment, reduction of intermediate storage, detected data from the incoming wagon can be used immediately for optimised reloading
6. noticeable reduction of damage claims of 75%, that are often exploited due to patchy in-/outbound ILU checks, IVG provides evidence and real time documentation
7. improvement of safety and security, integrity of the processes, especially due to the handling of dangerous goods



TD 5.4.1 supports terminal management systems as data hub to simplify in-/outbound operations and data flow, improve the quality of the required gapless documentation and increase terminal peak capacity by faster workflow and reduced dwell time for trains, trucks and ILU about 15%.

Following impacts will result from the **hybrid locomotive prototypes** retrofitted and tested as a demonstrator in **5.4.2**:

1. 20% reduction of CO2 emissions providing an environmentally friendly second life
2. 20% reduction of Diesel consumption
3. 10% reduction of LCC cost
4. 50% reduced investment costs compared to new built locomotive
5. Improved safety through better visibility and greatly reduced noise emissions
6. Improved maintainability

The hybrid shunting locomotive will spend between approximately 50 percent of its service time in battery mode depending on its use. This makes it possible to achieve zero-emission rail transport in urban areas or production halls. It also marks the right development at a time, where zero-emission freight transport will play an increasingly important role in sustainable CO2 reduction worldwide.

Besides the huge direct impact which cannot be understated, hybridisation will make it possible to decide on large-scale refurbishment particularly in Eastern Europe where up to date, not a single locomotive has been hybridized. While the investment in new hybrid shunters is economically not feasible for many RUs, hybridisation of the legacy shunting fleet will be have a special importance in setting a path for cost-efficient green technology – available in the short term.



## Strategic Impact

**Table 47: Strategic Impact of TD5.3**

Strategic Aspect	Key Contribution from the TD
<i>Support the competitiveness of the EU industry</i>	<ul style="list-style-type: none"> <li>• Technological leadership supported by a new ground-breaking technologies for refit of existing assets, marking an effective advantage for the European industry</li> <li>• Tangible benefits from both focus areas will result for rail freight:               <ul style="list-style-type: none"> <li>○ Video gates will Increase degree of automation, operational capacity and reliability of intermodal transport and terminal operations</li> <li>○ Significant reduction of energy consumption by shunters in marshalling and in delivery to customer sidings</li> </ul> </li> <li>• Additional knowledge and an ideal engineering basis will be created for introduction of further innovative propulsion technologies (i.e. gas engine) in following innovation projects</li> </ul>
<i>Compliance with EU objectives</i>	<ul style="list-style-type: none"> <li>• Promotion of modal shift: A big impact brought by the implementation of cost-cutting and performance-enhancing technologies towards a more competitive rail freight offering</li> <li>• Support to capacity increase: More throughput through terminals and more efficient utilisation of shunters will enhance capacity significantly</li> <li>• Greening of will be achieved by reducing both energy consumption and CO2 emissions by 20%</li> </ul>
<i>Degree of maturity of the envisaged solutions</i>	<ul style="list-style-type: none"> <li>• For the recommended two pilot terminals to be equipped as demonstrators and two prototypes of a hybrid locomotive the TRL level reached must be 7, in order to demonstrate the operational capacity for handling of the technology, verify the impact and come as close as possible to a marketable product development with impact in 2020</li> </ul>

### **5.5.5.5. Implementation of the work programme**

For “**Intelligent Video Gate Terminal (IVG)**” the idea is to define, develop and install intelligent video gates in 2 pilot terminals. Intelligent video gates will consists of hardware for the rail gate, power supply, lights etc., imaging components (cameras, sensors, etc.) and software for object capturing, recognition and data processing.

IVG focusses on the:

- Automated recognition of all ILU types, wagon and dangerous goods with high data accuracy at the train gate
- Automated comparison with pre-defined data including deviation reports
- Fast data transfer/communication via non-discriminating interface to users and participating terminals
- Further developments for data integration captured from RFID.



The technology should be based on a high-resolution video image, detection methods based on algorithms with pre-defined patterns also applicable for dangerous goods. The patterns and algorithms will rely on established UIC-/ ILU standards for wagon and ILU identification. TRL in this activity will range from 3-7.

The concept of “**Hybridisation of Legacy Shunting Fleet**” will be to test two hybrid locomotive prototypes for an eco-efficient second life. Both prototypes will have the same technical design to receive representative results. Taking an existing, proven shunting locomotive as base for optimisation of shunting fleets, the intention is to demonstrate the capacity to retrofit innovative hybrid technology with powerful traction battery and optimised mission management for a shunter.

The hybrid concept itself will take into account prevalent and future load cycles. Unnecessary and necessary idle running will be separated out. Members will contribute the base locomotives, project management skills, technical and operational expertise and full capabilities to build up the prototypes.

The hybrid is one of the most efficient and eco-efficient propulsion solutions. In the heavy power class required, no European hybrid locomotive is available yet. Technologies like the gas motor and fuel cells are not far enough developed yet, nor is the necessary infrastructure for fuel developed yet. However, the hybrid is open to test further innovation: When more innovative technologies are mature, they can be implemented into the hybrid concept e.g. replacing the diesel engine. A state-of-the-art container/modularisation concept will be implemented to minimise downtimes of locomotives and to improve maintainability of the locomotive. A Lithium-Ion battery with advanced mission management for rail freight application will be implemented in the prototypes for testing until TRL 7, including the development of operational guidelines.

From an operational viewpoint, the hybrid shunter could take over two jobs – replace old shunters and operate in mainline traction services. The resulting gain in flexibility comes at a minimum cost and will benefit all of Eastern Europe.

#### **Description of Tasks:**

Tasks will be labelled according to the logic of the two focus areas TD 5.4.1 and TD 5.4.2:

#### **Task 5.4.1.1 – Development of the IVG Terminal concept (TRL 3)**

- Subtask 5.4.1.1.1 – Definition of basic layout, efficiency requirements, table of content for the recognition and detection in the railway-sided video gate

Today train inbound and outbound processes are carried out mostly manually. The IVG should lead to a higher grade of automation and better quality in the detection, capture, documentation, validation and processing of necessary information of loading units and wagons. This task contains the development of major criteria to capture essential information on the handling of the ILU and the wagon on which the ILU is transported. Therefore the expertise of terminal operators, railway undertakings and intermodal operators is needed to describe what information, where to find and what is essential, feasible and worth capturing by train gate technology. The result is a general specification which is the basis for the next tasks. The specification has to take into account the latest existing frameworks. DUSS will provide its latest work on train gates on video gates.



- Subtask 5.4.1.1.2 – Definition of detection patterns and processing algorithms to detect relevant information on wagons and ILU

Based on Task 1 in this task will be defined which relevant recognition patterns for the required information are important and by which method they are collected and processed in a train gate. The result is a technology-related specification, which must be considered to develop the train gate system. Therefore the technical expertise for camera capturing technologies as well as railroad standards should be used to choose the most effective and cost affordable technology. The recognition patterns should be based on the information given in legal or most common European or international standard definitions.

- Subtask 5.4.1.1.3 – Definition of the location requirements for the infrastructure and the hardware

The requirements for the train gate technology need to be described, what local infrastructural as well as technical solutions are to be placed on the site to host the hardware and enable intelligent capture systems at an affordable cost level. It also has to be specified, in which way maintenance on the IVG is necessary. Taking these results into account at least one demonstrator terminal will be selected by the participating terminal operators. The knowledge of planning and terminal layout as well as the experts for the system components of the train gate and its power supply and control requirements (such as electric power supply, etc.) is needed.

- Subtask 5.4.1.1.4 – Definition of the interface content and a model contract for the neutral and effective data transmission in pre- and follow-up systems

If the required and described data, images, etc. are detected from the ILU and the wagon in the IVG, they need to be compared and validated with transport data which are to be sent to the IVG in advance and also need to be reported back in terms of deviation reports. These data need a data processing system (data hub). In this task the partners need to develop and to describe the general data flow and interface requirements for safe handling and transfer of data as well as the conditions for model contract that need to be agreed by the partners of the data procession. For best results it is to taken into account that the two selected terminals have a traffic link, so that the data from both IVGs can be used for validation.

#### **Task 5.4.1.2 – Development of IVG components and roll-out plan (TRL 5)**

- Subtask 5.4.1.2.1 – Development of components, algorithms and simulation

Along with the specifications described in earlier tasks, the components and algorithms are to be developed or composed (engineering with suitable partners, subcontractor, external software companies, choice of appropriate hardware components as far as possible from existing market products). To this end, a first simulation in an integrated system is required. The simulation delivers first inputs for the later set up of the practical demonstrator.

- Subtask 5.4.1.2.2 – Rollout plan for pilot sites

The system developers and terminal operators have to prepare a rollout plan for the pilot sites.



### **Task 5.4.1.3 Demonstrator for IVG-Terminal Operation (TRL 7)**

- Subtask 5.4.1.3.1 – Implementation of pilot sites and real tests (practical demonstrator)

In this task practical demonstrators will be established at the selected terminals. Infrastructural implementation per site, functional test, monitoring and documentation per site, planning and permission infrastructure, system integration to local IT-interface and other defined interfaces from earlier task.

- Subtask 5.4.1.3.2 – Review

The strengths and weaknesses of the implemented system from the practical demonstrators are to be analysed and compared with the requirements.

**For “Hybridisation of Legacy Shunting Fleet” (TD 5.4.2) following tasks and sub-tasks are planned for implementation up to TRL 7:**

#### **Task 5.4.2.1 – Pre-study study of hybrid base application(TRL 3)**

The recording of freight and area-specific duty cycles takes place. Operational and maintenance needs will be formulated, the base locomotive will be selected and investigated. Technical requirements for retrofit will be analysed in cooperation with partners for engineering and assessment. Complementary, technologies for battery charging such as inductive loading points may be evaluated for charging of hybrid shunters within marshalling yards.

#### **Task 5.4.2.2 – Hybrid system design & engineering according to specification (TRL 4)**

The hybrid system design of the two prototypes will be specified in a technical Spec book, covering the specification of running gear, auxiliary systems, frame, cab, hybrid propulsion system and safety system for the retrofit of the chosen shunting locomotive. The Specification Book will be refined during research on relevant subcomponents, and completed with specific requirements for retrofitting innovative components. Testing of different concepts will be started in lab conditions. Following lab tests the base design will be reviewed and optimised for eco friendliness, energy consumption and durability.

#### **Task 5.4.2.3 – Implementation of technical solutions incl. preparation for authorisation (TRL6)**

The hybrid concepts will be implemented on two prototype base locomotives that will be provided within IP5. The modification of the base loco and installation of components will be performed. First test in an operations-like environment will take place. The authorisation process will be initiated in parallel with responsible authorities and external partners in yet to be specified countries.

#### **Task 5.4.2.4 – Prototype testing, operational testing and energy management optimisation (TRL 7)**

The prototype testing plan may be derived from previous modernisation and authorisation projects for re-motorisation projects. Prototypes will be tested in a fully operational environment following approval by the authorities. The different technical options on the prototypes and the energy management options will be tested and evaluated separately against the simple base design and the existing not modified fleet. At the end of the first testing phase the base design will be revised and



optimised. Testing over a longer period of time will be important to verify the reliability of the system design and optimise the hybrid concept under real conditions, especially the usability in the field and maintenance.

**Task 5.4.2.5 – Documentation of hybrid concept, lessons learnt and development roadmap (TRL 7)**

The outcomes of the operational testing from task 5.4.2.4 will be integrated in comprehensive project documentation which enables other parties to use the concept for integration into other shunting locomotives. The lessons learnt and the further development roadmap will be integrated in the documentation.

**5.5.5.6. Planning and budget**

**Figure 105: TD5.4 Gantt chart**

TD 5.4 - Marshalling Yards and Terminals		2016				2017				2018				2019				2020				2021			
Subject		Q1	Q2	Q3	Q4	Q1	Q2	Q3	Q4	Q1	Q2	Q3	Q4	Q1	Q2	Q3	Q4	Q1	Q2	Q3	Q4	Q1	Q2	Q3	Q4
<b>Hybridization of legacy shunting fleet</b>																									
1	Pre-study / feasibility study of base application	x	x	x	x																				
2	Hybrid system design & engineering according to specification				x	x	x	x																	
3	Implementation of technical solutions incl. preparation for homologation							x	x	x	x	x													
4	Prototype testing, operational testing and energy management optimization									x	x			x	x	x	x								
5	Documentation of hybrid concept, lessons learnt and development roadmap																	x	x	x	x				
<b>Intelligent Terminal Operation &amp; Design</b>																									
<b>1 Development of the IVG terminal concept (TRL 3)</b>		x	x	x	x	x	x																		
1.1	Definition of requirements and the table of content for the recognition and detection in the railway-sided video gate	x	x	x																					
1.2	Definition of detection patterns and processing algorithms to detect relevant information on wagons and ILU			x	x	x	x																		
1.3	Definition of the location requirements for the infrastructure and the hardware, etc.			x	x	x	x																		
1.4	Definition of the interface content and a model contract for the neutral and effective data transmission				x	x																			
<b>2 Development of terminal IVG components, software and roll-out plan (TRL 5)</b>										x	x	x	x												
2.1	Development of components, software, algorithms and simulation									x	x														
2.2	Rollout plan for pilot sites											x	x												
<b>3 Demonstrator-Rollout for IVG-Terminal Operation (TRL 7)</b>														x	x	x	x	x	x	x					
3.1	Implementation of pilot sites and real tests (practical demonstrator)													x	x	x	x								
3.2	Review																	x	x						

Timeline s. Excel

The estimated budget for the TD is around 11.3M€.

**5.5.6. TD 5.5 New Freight Propulsion Concepts**

**5.5.6.1. Concept and objectives of the New Freight Propulsion Demonstrators**

The current situation of EU rail freight traffic is not satisfactory. The actual rail market share in land freight transport for the EU-27 has been maintained in a poor fraction, dropping between 2000 and 2011 from 18.5% to 17.4%, despite an increasing penetration of new entrants in this market. The major objectives of the EU White Paper like the Shift of 30% of road freight over 300km to rail by 2030 or doubling the transport by rail freight compared to 2005 becomes hard to achieve.



Within this context, the final target of this TD is to provide more attractive rail freight services to the final customer, with competitive rail solutions maximizing flexibility and efficiency while reducing the operating and maintenance costs. The focus of this TD will be on improving the overall performance of today's locomotives by adding and integrating additional functionalities and technologies. Future locomotives will:

- Provide extreme flexibility for operation in non-electrified and in electrified lines, allowing private and public operators to offer broaden rail freight services according to demand without the need of changing the locomotive
- Featuring remote control for distributed power, thus, allowing the increase of the train length up to 1500m and consequently improving the cost efficiency of rail transport
- Recuperate braking energy as much as possible, store it onboard and to reuse it whenever required, for traction purposes, for peak shaving, to supply auxiliaries and others
- Provide more traction force
- Minimize the energy consumption on their journey, thanks to advanced driver advisory systems (DAS) that will be connected to traffic management systems of IMs
- Be more reliable while simultaneously reducing maintenance costs thanks to CBM.

Some of the results achieved in this TD will be of valuable interest also for passenger locomotives, thus supporting even more the overall goal of the modal shift.

**Technological output to be delivered by this TD:**

New powerful EU freight locomotives with flexible and network independent operation capabilities, supporting increased train lengths up to 1500m and reducing massively energy consumption, thus providing more attractive rail freight services to the final customer with competitive operating and maintenance costs.

**Specific achievements to be delivered by this TD:**

1. Provide high operational flexibility by implementing powerful dual power locomotives capable to run on electrified and non-electrified lines
2. Reduce energy consumption and air and noise pollution while providing high operational flexibility by integrating full electric last mile propulsion systems based on powerful Li-Ion batteries
3. Reduce energy and track access costs by supporting train lengths up to 1500m
4. Reduce wheel and track wear and access costs by developing innovative bogies for 6 axle locomotives, with new design concepts but also including new lightweight materials
5. Increase environmental performance of freight locomotives by more efficient subsystems, by being able to recuperate braking energy and store it on-board, e.g. with Li-Ion batteries, by implementing driver assistant systems linked to the traffic management systems, thus knowing the real time traffic situation to better implement energy saving measures and by using lightweight materials
6. Reduce maintenance costs by implementing improved monitoring systems (CBM) for better diagnostics and intelligence rolling stock.
7. Increase overall performance by offering the most flexible interface to the New Generation of Wagons, designed in IP5

The following table shows how the proposed activities will contribute to the achievement of the S2R objectives stated in the S<sup>2</sup>R Master Plan:

**Table 48: Objectives and deliverables of the TD**

S <sup>2</sup> R Objectives	TD Objectives	Practical contribution (how)
Improved services and customer quality	Greater flexibility of operation and interoperability with dual power locomotives, including powerful last mile propulsion systems	<p>Specification and development of systems and subsystems for dual power locomotives including the specification and development of alternative re-fit hybridisation concepts e.g. for last mile concepts.</p> <p>Specification, development and demonstration of a Li-ion battery for fully electric operation in any network, (with a few 100kWh energy and power range around 1MW).</p>
Reduced system costs	<p>Reduce energy and track access costs and improve productivity by supporting train lengths up to 1500m</p> <p>Reduce wheel and track wear and access costs by developing innovative bogies for 6 axle locomotives, with new design concepts but also including new lightweight materials</p> <p>Increase environmental performance of freight locomotives by more efficient subsystems, by being able to recuperate braking energy and store it on-board, e.g. with Li-Ion batteries, by implementing driver assistant systems linked to the traffic management systems, thus knowing the real time traffic situation to better implement energy saving measures and by using lightweight materials</p> <p>Reduce maintenance costs by implementing improved monitoring systems for better diagnostics and intelligence rolling stock.</p>	<p>Specification, development and authorisation of locomotives with radio remote control for regular operation of 1,500 m trains in Europe based on the MARATHON results</p> <p>Specification, development of next generation locomotive bogie</p> <p>Specify and integrate powerful recuperation Li-Ion batteries controlled by state-of-the-art mission managers to be developed.</p> <p>Link the driver assistant system to the traffic management system</p> <p>Implement and introduce CBM</p> <p>Adaptation of combustion engine calibration regarding efficiency thermal management and emissions</p> <p>Design and tailoring of waste-heat recovery systems enabling recuperation of heat energy and therefore increasing overall energy efficiency.</p> <p>Introduction of global energy manager enabling (a) the instantaneous optimisation for the use of the different energy sources available (context-dependent), and (b) long-term energy optimisation based on mission and load profile.</p>

S <sup>2</sup> R Objectives	TD Objectives	Practical contribution (how)
Simplified business processes	<p>Provide possibility to couple long trains up to 1500m.</p> <p>Implement improved monitoring systems for better diagnostics and intelligence rolling stock.</p> <p>Implement flexible interface to the New Generation of Wagons design</p>	<p>Develop and or integrate required subsystems, such as end of train (EoT) devices and radio remote control, start from the results of the MARATHON project and do the final steps including authorisation of such a consist.</p> <p>Improve today's monitoring systems.</p> <p>Define and implement the interfaces to the new generation of freight wagons</p>
Enhanced interoperability	<p>Implement powerful dual power locomotives capable to run on electrified and non-electrified lines.</p> <p>Integrate powerful full electric last mile propulsion systems based on powerful Li-Ion batteries</p>	<p>Develop a dual power multisystem locomotive with all relevant ATPs capable to run on all lines (electrified and non-electrified) within Europe.</p>

### 5.5.6.2. Technical ambition of the Systems Demonstrator

To overcome the current situation and to contribute to the modal shift from road to rail, the new locomotive must help rail operators increasing their competitiveness by:

- Providing greater flexibility for operation
- Being interoperable, including ERTMS and national ATP systems
- Being environmentally friendly, with an optimised traction system for every line
- Reducing wheel / rail efforts, which will diminish wear rates and hence maintenance costs
- Reducing operating costs by various means, including energy efficiency, track access costs, integration of driver assistant systems (DAS) and autonomous train operations (ATO)
- Being capable of operating longer and faster trains
- Minimizing the locomotive fleet of the operator

Even though some of the technologies already exist or are even implemented outside Europe, it still remains very challenging to integrate all of these in one locomotive.

- For instance, the integration of powerful diesel engines into multi system electric locomotives is a challenge today due to volume claim and maximum axle loads. New structural designs, including light weight structures need to be developed and will be essential components of future locomotives.
- The integration of all ATP systems required to run on a certain European corridor is often not possible due to the lack of space in the underframe to integrate all antennas, because transitions,



especially dynamic transitions are not possible with some national ATP systems, but also with respect to costs. The integration of ETCS on all lines is key and also necessary for other systems resp. functions that will be introduced in the future, such as for instance the autonomous train operation (ATO).

- Ambitious is also the development of an all-electric last mile device, especially concerning the energy quantity to be integrated into a main line locomotive. A powerful mission management, merging state-of-the-art traffic management and driver assistant systems to one overall control instance must still be developed.
- Powerful energy storage systems allowing full recuperation of braking energy were not introduced yet. Li-Ion batteries are available on the market, but their safety assessment and their certification is still a hurdle.
- Increasing train lengths up to 1500m requires not only an upgrade of the network infrastructure, but also the development of a safe and reliable radio remote control technology. The latter is very challenging for the European networks due to the geographical constraints and not comparable to similar systems used in other continents. Furthermore, certification of such a radio remote control has still not been tackled and the MARATHON project foresees important efforts to be done before reaching this goal.
- Integrating lightweight materials is a challenge often with respect to costs versus benefits
- Most of today's driver assistant systems (DAS) use timetable for computing the most energy saving driving style and so far are not linked to the traffic management systems. Thus, they are also not capable of computing in real time the driving recommendation. While the implementation in one traffic area, one country may be straightforward (and has been done in very few cases), the introduction of one system compatible all Europe is a challenge.

The ambition of this TD is to finally implement a locomotive complying with all requirements stated above. Such a locomotive would represent a quantum step with respect to the characteristics mentioned and offer to operators and customer enormous advantages.

### **Shift2Rail Vision of the propulsion TD**

The vision for the freight propulsion TD proposed in Shift2Rail is based on the expected evolution of fundamental technologies applied to the following four focus areas:

1. **Future freight locomotives:** The aim of this work stream is to specify, design, develop subsystems and systems for the future freight locomotive, including dual power hybrid variants, the use of lightweight materials, two or three axle track friendly, low noise bogies, energy storages for the recuperation of braking energy, etc.
2. **Full electric last mile systems** based on Li-Ion batteries including state-of-the-art mission management systems. The aim of this work stream is to specify, design, develop, commission and authorise a full electric last mile system based on state-of-the-art Li-Ion batteries. Beside technical issues, focus is on the authorisation part, which is seen as a challenge due to missing standards.

3. **Long freight trains** up to 1500m with distributed power and brake capabilities: The aim of the work stream Longer Trains (LT) is to fully develop a technical solution for the regular operation of 1,500 m long freight trains. The project is meant to identify the actual market potential, a technically secure and operational reliable realisation of longer freight trains, the needs for a specific authorisation for longer trains with distributed power and no driver on the second loco, necessary measures to infrastructure, operations and rolling stock and the economic effects for RUs and IMs in a business case. The technological progress will be shown in different technology demonstrators within the project. The project objectives are based on the results of MARATHON project, which showed the general reasonability and practicability of this approach of 1,500 m long freight trains. The next step to clear the remaining open points must be to prepare an European regular traffic of LT.
4. **DAS connected** to the various traffic management systems. The aim of the work stream C-DAS is to develop and implement a European standardised electronic interface for exchanging driving advices between IMs and RUs and to conduct interoperable real life trials on the core network and develop a roadmap for a European Implementation of the system

The following table summarizes how this TD will progress the state-of-the-art and overcome today's limitations and difficulties:

**Table 49: Ambitions and advance beyond state-of-the-art for TD5.5**

State-of-the-art	Ambitions and expected advance beyond state-of-the-art
4 axle multi system or diesel locos, no combination on the market capable to pull heavy train over longer distances at adequate speed	The freight loco of the future, 4 to 6 axle dual power multisystem loco (e.g. 6MW electric and 4MW diesel), with powerful energy storage systems (recuperation Li-Ion batteries). This includes specification and development of the subsystems and (lightweight) materials required to reach the goal.
Last mile propulsion systems based on diesel engines or small lead-acid batteries	Integration of powerful Li-Ion batteries giving possibility to run on a last mile with high power during a relative short time e.g. over 1MW for 15-30min. This includes the development of a high efficient hybrid propulsion system, an optimised cooling and heating system, the development of a powerful mission management system (could be linked to the DAS below), the authorisation of such a system and last but not least, the demonstration.
Train lengths usually limited to 750m in some special cases up to 850m. No radio remote controlled distributed power implemented so far in Europe	Based on the MARATHON results, tackle the last remaining open points, with focus on authorisation of such systems, including a demonstration
Few DAS with link to traffic management system have been implemented so far and are limited to one operator or region	Definition and implementation of an European standard for DAS systems connected to the local traffic management systems, including the required interfaces and a demonstration



The following EU funded projects will be applied to the next generation freight locomotive:

Project	Input
FP7 CleanER-D (2009 – 2013)	Railway rolling stock powered with diesel engines compliant to the requirements of stage IIIB of the Non-Road Mobile Machinery (NRMM) European Directive.
FP7 Marathon (2011 – 2014)	Radio link between locomotives to operate faster, longer and heavier freight trains.
FP7 Refresco (2013 – 2015)	Regulatory Framework for the use of structural new materials in railway passenger and freight carbody shells.

The main interactions envisaged within S2R are:

- IP1 – TD “Running Gear”: Applying the new bogie generation technologies (for new sensing and suspension systems) to a freight bogie.
- IP1 – TD “Traction Systems”, whose results will flow directly or indirectly into the converters required for interfacing batteries to the traction chain of the locomotives.
- IP1 – TD Carbodyshell: Interaction for application of light materials to freight locomotives.
- IP2 – Advanced Traffic Management and Control Systems (ERTMS/ETCS) for cross-border operations.
- IP2 – ATO. Together with IP5, TD5.6, integration of relevant subsystems in the locomotive
- IP5 – TD Freight Electrifications, Brake and Telematics: interfaces to condition based maintenance for locomotives and to wagon telematics are crucial to develop and demonstrate new technologies. Any propulsion technologies developed will be suitable for condition based maintenance. Also the development of a master controller in charge to manage the communication backbone and the radio channel is foreseen.
- IP5 – TD Access and operation: interfaces for data communication between locomotive, wagons and data centers.
- Transversal activity NoV for technologies reducing noise and vibration on locomotives



### 5.5.6.3. Specific Demonstration activities and contribution to ITDs/SPDs

The overall S2R goals will be addressed by the four (4) focus areas summarized in the following table.

Rsearch Area	Focus area	Specification Activities?	Demonstrator TRL	Focus of activity
New Freight Propulsion Concepts	Freight Loco of the Future	Concepts and specifications	2/3, for some subsystems up to TRL7	<p>Generic, specification of 6 vs. 4 axle, definition of power requirements including last mile, specification, design and development of bogie, energy efficiency, remote control via radio without driver for freight loco of the future.</p> <p>Study of applicability of new technologies on retrofitted locomotives.</p> <p>Subsystem specification and validation with functional mockups and laboratory prototypes.</p>
	Last Mile Propulsion Systems	Architecture, specifications (HW, SW, Test, etc), documentation for construction and commissioning.	7	<p>Li-Ion batteries, recuperation, authorisation, mission management system, maintenance, system optimisation &amp; peak shaping, definition of last mile, assessment of batteries</p> <p>Both for new and retrofitting of Locos</p> <p>Demonstrator Loco in operation (TRL7)</p>
	Long Trains up to 1500m	Development authorisation documentation	7	<p>Marathon Project is baseline, focus is now getting authorisation of a train with no driver on the 2nd Loco</p> <p>Phase 1: Development of a European Longer Train Concept including the coordination of an European recognized certification method for operating Longer Trains and identification of the operational and infrastructural constraints</p> <p>Phase 2: Realisation of Technology Demonstrators by developing and testing of a distributed power solution by radio remote control</p> <p>Phase 3: European Authorisation and Rollout preparation including the development of a European roadmap for the implementation of Longer Trains</p>
	Driver Advisory System	Definitions & specifications	6/7	Definition, implementation and testing of a European standard for communication for DAS between IMs and RUs for Freight



#### 5.5.6.4. Impact of the Systems Demonstrator

In this section, a summary of the strategic impacts produced by the implementation of the TD results and discoveries is given.

Strategic Aspect	Key Contribution from the TD
Support the competitiveness of the EU industry	<p>Technological leadership supported by a combination of the development and final implementation of innovations and technical standards, setting an effective advantage for the European industry. Tangible benefits for the end user:</p> <ul style="list-style-type: none"> <li>• Increase the flexibility of rail freight system for operation under the TEN-T corridors, the main EU lines and under the non-electrified feeder lines, providing cost savings by using the most efficient traction mode according to the infrastructure.</li> <li>• Allow the free circulation of freight trains for cross-border transport.</li> <li>• Operation of longer trains and reduction of operating costs.</li> <li>• LCC reduction through energy savings, monitoring and diagnostics improvements and new low weight and friendly freight bogie.</li> </ul>
Compliance with EU objectives	<p>Promotion of modal shift from road to rail is expected with the improvement of rail freight competitiveness. Support to capacity increase, which is expected by lengthening the trains up to 1500m. Greening of transport through the implementation and demonstration of environmental friendly solutions and optimisation of energy consumption, hence contributing to the EU target for CO2 reduction too.</p>
Degree of maturity of the envisaged solutions	<p>The proposed work involves a big step in the degree of maturity of the technologies to be applied in the freight rail transport. At the end of Shif2Rail it is expected that the successful concepts are brought to TRL 7.</p>
Authorisation as key to success	<p>A successful integration and authorisation of the locomotive including the last mile traction battery will have enormous impact on future battery related developments. In fact, a variety of battery based implementations is foreseen, consisting of different sizes of battery systems, of battery systems with different chemistries and different characteristics, and even consisting of battery systems with modules dispersed along whole trains.</p>

### 5.5.6.5. Implementation of the work programme

In order to guarantee that the desired final objectives are met a clear methodology has been devised for the organisation of the technical work in the TD. This is represented in the following schematic representation:

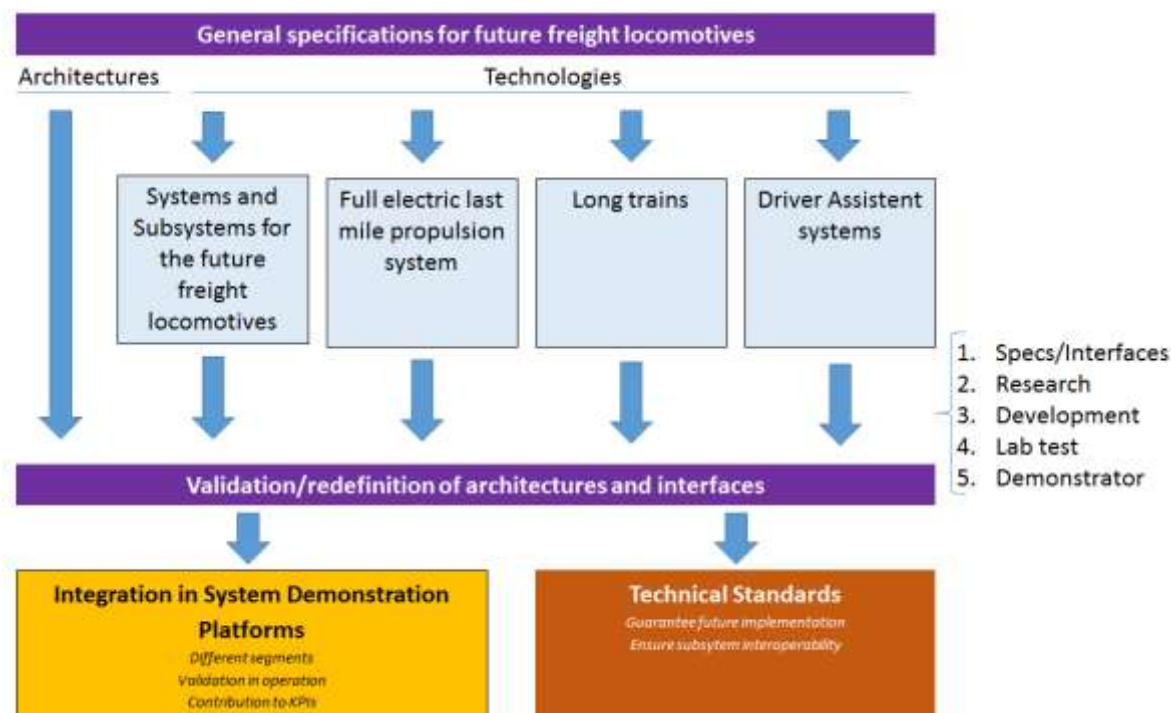

#### **Task 5.5.0. Feasibility studies (indicative (TRL 3)):**

The contribution of the participants will cover the following:

##### ***For future freight locomotive:***

- Specification of future freight locomotive with focus on 6 axle locomotive and energy storage systems and on hybrid locomotives, energy efficiency improvement and refurbishment
- Definition of requirements based on business case, system and component targets for the freight loco of the future

##### ***For full electric last mile system:***

- Feasibility and subsystem descriptions with the interest of connection towards, for example TD 5.4 Novel terminal.
- Definition of “last” mile and of system size (kWh, kW) for LM system
- Definition of requirements based on business case and last-mile subsystem targets

##### ***For long trains:***

- Follow up and development of the experiences from MARATHON project



- Re-assessing the MARATHON results with respect to compatibility of the system employed and the ones on general European locomotives.
- Definition of activities to be performed for integrating and assessing radio remote distributed power in European locomotives.
- Innovation scouting technology transfer opportunities, studies on network capacity and the technology assessment for coupled trains with radio controlled distributed power.

***For DAS-C:***

- Further develop capacity and energy efficient driving support systems such as CATO
- Contribute in defining the interfaces between the DAS and the locomotive, what must be visualized to the train driver, etc.
- Requirements and concept of a European C-DAS with a modular system design in coordination with IP2
- Contribution to definition of DAS-C requirements

**Task 5.5.1. Subsystem technology Specification (indicative TRL 3):**

The objective of this task is to define the requirements for the future locomotive. The desired performance and specific rail constraints will be defined. Following subtasks (focus areas) include: Freight Locomotive Propulsion, Control, Brake System, Energy Storage System, Auxiliary System, and Bogie.

The contribution of the participants will cover the following:

***For future freight locomotive:***

- Lighter material, low noise and track friendly developments, (subsystem level)
- Requirement specification of 3 axle track friendly bogies and on-board Li-Ion based energy storage systems
- Detailed subsystem specification for hybrid locomotives including freight locomotive propulsion and Energy Storage Systems based on Li-Ion technologies
- Requirement specification of 3 axle track friendly bogie and propulsion systems and energy storage systems based on Li-Ion technologies

***For full electric last mile system:***

- Requirement specification of subsystems for last mile propulsion systems, including batteries, HVAC, high voltage components and the mission manager
- Requirement specification of last-mile propulsion subsystem incl. energy requirements, EMC, thermal management and safety

***For long trains:***

- Follow up and develop the experiences from MARATHON project
- Requirement specification of gateways, components and interfaces to standard locomotive components
- Specification for a European distributed power solution by radio remote control, concepts for operational simulation and European proof of safety and authorisation of locos

***For DAS-C:***

- Further development (specification) of capacity and energy efficient driving support systems such as CATO and in specifying in connection with TD 5.2 the interface with Traffic management / control system performances
- Requirement specification for DAS-C on-board systems, including DAS-C interface between RUs and IMs TCMS

**Task 5.5.2. Subsystem technology development (indicative TRL 5):**

The contribution of the participants will cover the following:

(According to the specifications developed in Task 5.5.1):

***For future freight locomotive:***

- Development of 3 axle bogies and subsystems for energy storage
- Development of freight locomotive propulsion and Li-Ion ESS prototype subsystems for hybrid locomotives.
- Validation with functional mockups & laboratory prototypes (up to TRL4) of freight locomotive propulsion and Li-Ion ESS subsystems.
- Development of a track-friendly 3-axle bogie and to the development of powertrain and energy storage concepts and subsystems

***For full electric last mile system:***

- Development of full electric last mile system
- Last mile system optimisation with respect to energy management, thermal management, traction controller

***For long trains:***

- Follow up and development of the experiences from MARATHON
- Development of coupling freight train concepts and requirements for the interfaces between subsystems as an input for technology development of the industrial partners

**For DAS-C:**

- Further development of capacity and energy efficient driving support systems such as CATO
- Development of interfaces to locomotive TCMS
- Development of components both on side of IMs and RUs for testing in test-labs
- Enhancement of DAS-C strategies

**Task 5.5.3. Fully electric last mile propulsion system (indicative TRL 2-6):**

The objective of this task is to study, specify (TRL 2) and develop/validate (TRL 4) a fully electric last mile propulsion system based on Li-ion batteries including a mission management and the proof of concept (TRL 3) with the demonstrator and with the authorisation of the system (TRL 6). With the new structure of the MAAP, the activities are performed in the various Tasks 5.5.0 – 5.5.5. This Task will now focus on the mission management only.

The contribution of the participants will cover the development of the mission management system for last mile propulsion systems including predictive energy management

**Task 5.5.4. Manufacturing of the demonstrator (indicative TRL 6.)**

This task will focus on the development of the detailed design, drawings, manuals, design development for manufacturing, etc. to guarantee traceability throughout the design process and the later manufacturing.

The contribution of the participants will cover the following:

***For future freight locomotive:***

- Manufacturing of subsystems

***For full electric last mile system:***

- Manufacturing of subsystems, including testing and product introduction
- Integration of components and systems in locomotive demonstrator

***For long trains:***

- Demonstration between Germany and Sweden
- Integration of components into a locomotive platform in service. Perform testing and product introduction
- Realisation of technical demonstrators in the fields of:
  - Operations of pushing action with distributed power
  - Operations of coupled trains

***For DAS-C:***

- Demonstration between Germany and Sweden
- Integration of components into a locomotive platform in service, testing and product introduction
- Demonstration of the functionality via on-line tests on border-crossing relations under participation of different IMs and RUs
- Integration of DAS-C strategies in locomotive demonstrator

**Task 5.5.5 Authorisation (indicative TRL 6):**

The objective of this task is to obtain the authorisation certificate and to prepare tests in order to perform the final demonstration phase.

The contribution of the participants will cover the following:

***For future freight locomotive:***

- Assess subsystems and define requirements and assessment of the Li-Ion batteries
- Assess and validate Li-Ion battery development and support the locomotive authorisation

***For full electric last mile system:***

- Define requirements and assessment of the last mile propulsion system, including setting up of the demonstrator
- Assessment and validation of full electric last mile propulsion system on the demonstrator

***For long trains:***

- Demonstration and authorisation of a demonstrator between Germany & Sweden
- Contribute in authorisation of system. This includes contribution in setting up the demonstrator
- Development of a European authorisation and Rollout concept

***For DAS-C:***

- Assessment of the interface with traffic management/control system performances, including setting up of the demonstrator
- Development of a European authorisation and Rollout concept
- Assessment and validation of DAS-C on the demonstrator and support authorisation







transport automation for its own advantage to offer cost-effective, flexible and attractive service to shippers taking freight away from the already-congested road network.

Today's world of logistics is changing rapidly through automation: At modern harbours, Automated Guided Vehicles (AGVs) carry shipping containers from crane to trackside. Contract logistics providers are implementing AGVs in warehousing and distribution. Auto-pilots are standard on air carriers and huge cargo ships, allowing minimum on-board personnel. Whereas other modes have been quick to automate transport, rail runs the risk of lagging behind. There are only few exceptions, primarily in Australia where the world's first fully-autonomous heavy haul, long-distance railway is created. Although rail freight has the system advantage that is protected against lane change there is still no solution for autonomous mainline transport on the market.

The main objective of this TD is to develop a demonstrator of rail freight automation, building on base technology developed within TD 2.2. The aim is to actively pursue the objective of Autonomous Train Operation (ATO) realized progressively until 2030, for mainline freight operation and the underlying operations in order to increase railway's competitiveness with road freight, achieve operational efficiency gains and optimised resource utilisation.

#### **Technological output to be delivered by this TD:**

By 2020 TD5.6 will, in close linkage to TD2.2, test and validate a complete solution for ATO of a rail freight pilot on European mainlines from basic specification of system functionalities up to full testing of a test train on an international track section.

The tests will accordingly be held starting with GoA (Grade of Automation) 2 with supervisor in cab, testing the system for semi-automated operation in near future scenarios, and extending the functionalities gradually to testing of unattended operation under GoA4 for long-term future scenarios. ETCS level 2 Baseline 3 in the most recent maintenance release and the ATO module developed in IP2 will be the basis. The development will focus on:

- Implementation of the ATO module (auto-pilot) commanding loco control optimised for freight profiles, technically realized outside the safety-relevant ETCS architecture;
- Obstacle detection by means of sensor-fusion from radar, lidar and stereo camera systems for short distance shunting onto buffers, and long distance forward-looking driving;
- Fall-back levels built on system self-diagnosis for cases of failure or emergency.
- The tests on pilot lines will provide:
  - Full scale demonstration of the technology of implementing ATO over ETCS;
  - Full scale demonstration of ATO behaviour within actual Mainline operational constraints (e.g. mixed traffic with fitted and non-fitted trains);
  - Evidence of the interoperability of implemented solutions.

**Specific achievements to be delivered by this TD:**

The aim of TD 5.6 is to test and validate ATO technology up to autonomous operation (GoA4) in rail freight. The objectives are:

- To improve the quality of rail freight in terms of punctuality, reliability and flexibility
- To reduce the operating costs maximizing energy savings and resource efficiencies
- To increase transport capacity on lines and hubs of the European TEN-T network
- To make an important contribution to the vision of a fully automated rail freight system

The following table shows how the activity proposed will contribute to the achievement of the S<sup>2</sup>R objectives as stated in the S<sup>2</sup>R Master Plan:

Objectives		Desired outcomes
<b>Improved services and customer quality</b>	Improved reliability	Quality of service is enhanced due to a better punctuality (Arrival and departure times will no more depend on the driver way to drive).
	Enhanced capacity	From 10% to 50 % capacity increase is achieved by reducing the minimum operational headway between trains due to automatic driving.
<b>Reduced system costs</b>	Energy Saving	From 12% to 20% by automatic driving based on optimised speed profiles taking into account the track configuration, the expected arrival time and the presence of other trains downstream.
	Operation Costs	Reduction of fixed cost (increase of staff productivity)
<b>Enhanced inter-operability</b>	Respect and adaptation of TSIs Removal of open-points	The specification for interoperable ATO over ETCS will lead to TSI adaptation.

**5.5.7.2. Technical ambition of TD 5.6**

With underlying train guard system, i.e. safe in terms of signalling and track access, the demonstrator aims at a state-of-the-art development in multiple dimensions relevant to rail freight:

- With the ATO module to be developed and validated, the intention is to achieve the most energy-efficient, timely and reliable transport plan realisation possible.
- Sensor technology in current land transport research is able to look some 200m ahead. The required rail obstacle detection interfacing with loco control will be able to look ahead up to 1,000m detecting objects on and near track which may potentially interfere with the clearance and ground profile. It will safely identify patterns knowing to differentiate e.g. the position of trackside poles from a human.
- By definition “Automatic Train Operation” Systems have an impact on trackside and train-borne as well. This requires that the operational rules and technical specifications are interoperable; permitting every equipped train to be operated on the different infrastructures.

- For worst-case scenarios such as fire on board of autonomous trains state-of-the-art fall back levels will be designed to react appropriately even in case of dangerous goods transported. In cases of ATO failure, safe radio control must serve as fallback option for the locomotive to establish a secure state and be driven via remote control into the next depot, building on the TD development of Longer Trains.

The “**Pilot line**” demonstrators will involve actual signalling subsystems: TMS, Interlocking and ETCS upgraded with ATO features. The on-board and trackside technological elements are displayed in the following:

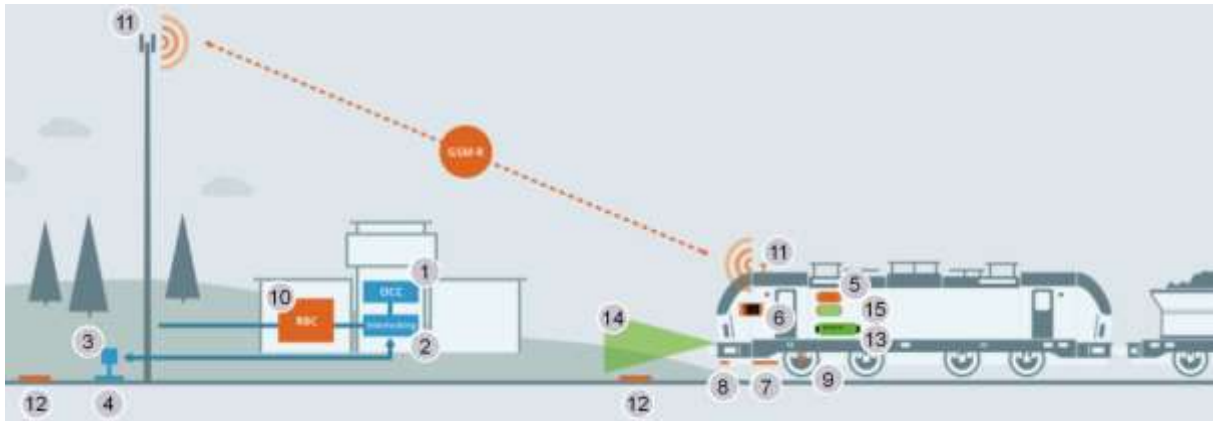

Interlocking components <i>Ensure safe routes and train separation</i>	ETCS Level 2 components <i>Ensure safe speed limits</i>	Automated Driving components <i>Drive train and supervise system</i>
1. Operation control center 2. Interlocking 3. Track vacancy detection indication (TVDI) 4. Vacancy detection	5. European vital computer 6. DMI 7. Balise antenna 8. Radar 9. Odo Pulse generator 10. Radio block center 11. GSM-R 12. Eurobalises	13. Automated Train Operation module (ATO) 14. Obstacle detection (s. below) 15. CBM board computer

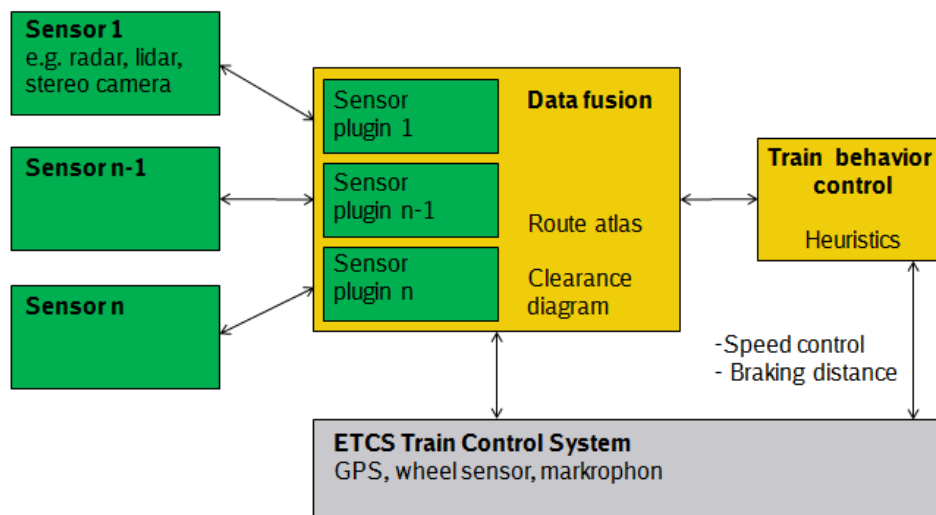

### Threads of obstacle Detection

However, it is not just a lack of technology that's keeping trains from going driverless; therefore an efficient process of certification and authorisation will be needed for ATO implementation. The ambition is to achieve a marketable and adoptable standard solution within the IP2/IP5 collaboration as a key output of Shift2Rail in order to realize GoA 2 with obstacle detection in series until 2030.

The main interaction envisaged is with:

- IP2 – TD2 « Railway Network Capacity Increase (ATO up to GoA4) »: The freight pilot will implement prototypes developed in the scope of TD 2.2 .

Also there is interaction foreseen with:

- IP5 – TD 5.1 « Automatic Coupling » and « Condition-based Maintenance »;
- IP5 – TD 5.2 « Real-time Yard Management »;
- IP5 – TD 5.3 « Freight Wagon 2020 »;
- IP 5 – TD 5.5 « Longer Trains » and « Connected Driver Advisory System »;
- IP2 -TD3 « Moving Fluid Block »;
- IP2 – TD4 « Fail Safe Train Positioning »;
- IP2 – TD 5 « On-board Train Integrity »;
- IP2 – TD8 « Virtually Coupled Train Sets ».

### Shift2Rail Vision of TD 5.6

ATO is of key importance to attractive and sustainable future rail freight. It will reduce system costs fostering optimal energy-efficient, low-wear, resource-efficient and flexible operation. The newly established TD is indispensable to actually achieve the objectives of improved services and customer



quality, enhanced interoperability and simplified business processes. As a result of Shift2Rail, autonomous freight trains must be able to deliver goods safely, reliably and energy-efficiently making rail the first choice for European freight customers on medium and long distances. In order to realize this vision, the focus on train automation comes first and is the scope in the planned demonstrator. First and foremost, IP5 must drive the development of intelligent auto-piloted freight trains which know their exact position, control the locomotive under ETCS supervision, react automatically to obstacles, offer safe fall-back solutions in case of failure and interoperate on European corridors.

**Table 50: Ambitions of TD 5.6**

Strategic Aspect	Key Contribution from the TD
<i>Support the competitiveness of the EU industry</i>	The intention is to make rail freight automation a European endeavor on the path to realize the Shift2Rail and the EU White Paper objectives. Only if it is possible to test new technologies for freight automation on European tracks, the research community and suppliers industry will remain strong in Europe. Otherwise these developments are most likely to be carried out outside the European industry.
<i>Compliance with EU objectives</i>	European objectives are quality and reliability of freight services, considerably improved cost competitiveness and the ambitious growth objectives that were set in the Transport White Paper in terms of developing rail freight. Autonomous Train Operation is the IP5 initiative with the greatest impact on these target dimensions, and will be key to boost rail freight innovation in the long term.
<i>Degree of maturity of the envisaged solutions</i>	At the end of the Shift2Rail period it is expected that the successful concepts are brought to TRL 7 ready for market implementation on TEN-T corridors under the CEF scheme

### **5.5.7.3. Specific Demonstration activities and contribution to ITDs/SPDs**

In close collaboration with TD2.2, the evolution towards “unattended operation” (GoA4) must be implemented incrementally. It should start with “Semi-Automated” operation (GoA2) on applications where the benefits could be achieved rapidly with GoA2.

The different steps from the current situation (GoA1 – Manual operation supervised by ETCS) to the highest Grade of automation (GoA4) should be backward compatible with the preceding situation in order to take into account the very long migration periods which characterize Main Line operation.

TD 5.6 will take as its baseline the work being performed within:

- The TEN-T 3<sup>rd</sup> call Technical Interoperability Requirement for ATO over ETCS (GoA2);
- The Operation Concepts updated according to the results of the European NGTC project.

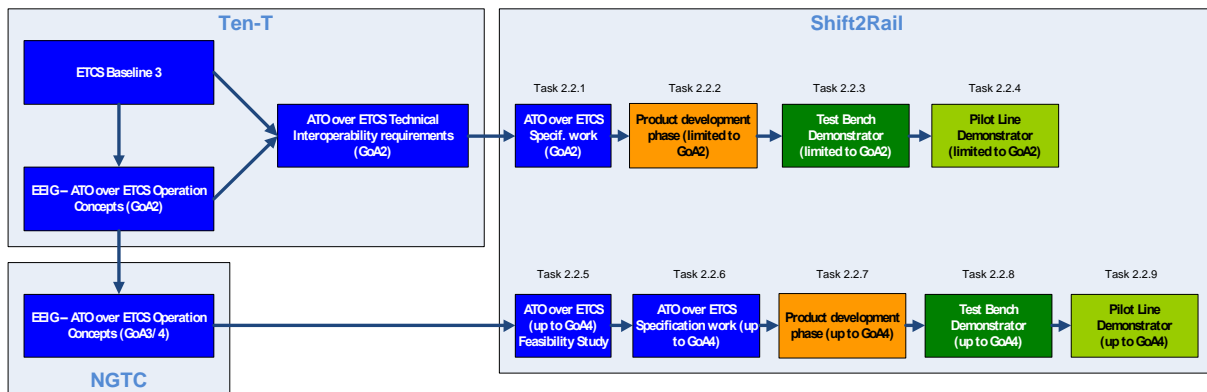
**Table 51: Work scheme for advance beyond state-of-the-art**

The results of the TEN-T programme (GoA2 concepts and requirement) will be implemented (prototypes) and validated in order to provide a GoA2 solution ready for deployment in 2019.

The results of NGTC (GoA3/4 operation concepts) will be studied, implemented and validated in order to provide a GoA3/4 solution ready to deploy in 2024.

#### **5.5.7.4. Impact of the Freight ATO demonstrator**

##### **Technical Impact**

ATO in its final implementation stage (GoA4) will create following advantages for freight transportation:

- 20% energy saving by automatically optimised acceleration and braking patterns for rail freight profiles
- 50% increase of production capacity doubling the throughput through infrastructure by reducing required headway
- 50% reduction of cost for drivers
- 10% efficiency increase by higher availability and easy disposition of assets
- Significantly improved punctuality by optimised on-time departure and delivery
- Significantly improved reliability by reduced dependency on and risk of human factor
- More accurate forecast of departure and arrival times for customers
- Flexible adaption of the frequency of trains and flexibility towards changing customer requirements
- Relief of staff, prevention of accidents and of psychological damage to drivers
- Creation of new opportunities in dealing with labour market trends

In light of these impacts resulting in a system cost reduction in the three-digit million Euro range, as well as great customer benefits, this proposed initiative is of highest priority for the future of European rail freight. This one innovation will be able to achieve the turnaround of European rail.

On the contrary, if the TD will be declined and autonomous freight transport will be left to the trucking industry, the resulting heavy loss of modal share could draw an end to European wagon-load transport.

### **Strategic Impact**

**Table 52: Strategic Impact of TD5.6**

Strategic Aspect	Key Contribution from the TD
<i>Support the competitiveness of the EU industry</i>	<ul style="list-style-type: none"> <li>• Technological leadership supported by the rail freight demonstration of ground-braking technology for the European industry</li> <li>• Tangible benefits an autonomous freight test train running across Europe to showcase and validate the capacity for rail automation</li> <li>• EU industry including manufacturers, operators and infrastructure managers will make rail freight automation a priority development</li> </ul>
<i>Compliance with EU objectives</i>	<ul style="list-style-type: none"> <li>• Promotion of modal shift: Maximum cost impact and improved competitiveness will result from automation of the rail freight system</li> <li>• Support to capacity increase: More throughput through bottlenecks will allow to improve line capacity</li> <li>• Driver qualification: International freight on distances &gt; 300km will be facilitated and generate growth if trains go unattended</li> </ul>
<i>Degree of maturity of the envisaged solutions</i>	<ul style="list-style-type: none"> <li>• For the recommended 2 pilots showing GoA 2 and GoA 4 operations on the European mainline, the TRL level reached must be 7, in order to demonstrate the operational capacity for handling of the technology, verify the impact and come as close as possible to a marketable product in 2020</li> </ul>

#### **5.5.7.5. Implementation of the work programme**

The implementation of the project is planned up to 7 in the following tasks, starting specification of freight specific GoA 2 requirements and resulting in international pilot line demonstration of technologies and processes under GoA 2+ (supervisor plus obstacle detection) and GoA 4 (unattended operation). Depending on the contribution of founding members and in the context of collaboration with TD2.2, a rail freight base locomotive, ETCS Level 2 and ATO technology will be used for both demonstrators on suitable track, potentially TEN-T corridor 1, in co-operation with national infrastructure managers.

#### **5.6.1 Freight ATO – GoA 2 Specification**

This tasks serves to:

- Review the ATO over ETCS specification according the Operation Concepts update defined in NGTC.



- Prepare the prototyping and testing phase on demonstrators.

It will include:

- The specification of the off-site and on-site tests to be executed in order to demonstrate the interoperability of the GoA 2 features;
- The consolidation of the GoA 2 specification (output of TEN-T programmes) according to the results of test campaign performed in laboratory and in the pilot lines;
- The specification of operating procedures under GoA2;
- Prognosis of costs/benefits incl. impact on staff qualification;
- the definition of the mitigations for the hazards identified in the feasibility study, development of emergency and failure concepts including the fallback levels optical signal detection and remote control;
- the specification of the system requirements, and overall architecture of ATO with obstacle detection considering also future extended functionality, e.g. automatic train preparation;
- specification of interfaces to external systems (e.g interlocking, TMS, maintenance systems) and further innovations planned, e.g. free float optimisation C-DAS (TD 5.5)
- Specification of obstacle detection requirements for detection of obstacles up to 1,000m ahead through advanced sensor technologies in order to comply with future standards for path monitoring and collision prevention
- Specification of on-board monitoring of critical components and intelligent self-surveillance for reliable system functioning (train integrity surveillance, smoke detection etc.) with a link to TD 5.1

This activity is synchronized with TD 2.2. TD 5.6 will guarantee the compliance with operational rail freight concepts contribute to the specification to ensure that the freight operation will be fully taken into account. Additional contributions are expected from other rail freight operators to help specify ATO requirements applicable for all of the European operators.

#### **5.6.2. Freight ATO- GoA 2 Prototype Development**

The aim of this task is to develop prototypes in line with the ATO over ETCS interoperable system specification developed for the GoA 2.

ATO on-board and wayside technology will be developed for use on mainline freight locomotives (electric or Diesel/electric) to be interfaced interoperably with ETCS on-board units. Different architectures are planned by the manufacturers in TD 2.2, with following focus from an ATO on-board point of view:

- Development of an ATO over ETCS prototype with the main objective of minimizing future upgrade of existing ETCS OBU equipment.





- The development will consider and study all the possibilities to run the ATO application over the existing EVC's HW, taking into account the operational concepts derived from NGTC project.
- Safety implications will be specially considered in order to mix ATP SIL4 functionalities with non-safety ATO functionalities.
- Thus, the prototype will not only be a functional demonstrator, it will also be used as a demonstrator of the mixed SIL safety architecture.
- Energy efficiency concepts will be also included in the scope of the ATO OBU prototype, as well as comfort and mechanical wear optimisation

This activity is led by TD 2.2 with input from TD 5.6.

#### **5.6.3. Freight ATO -GoA 2 Test Bench Demonstration**

The aim of this activity is to develop test benches permitting to integrate prototypes from different suppliers. TD 5.6 will specify the rail freight operation scenarios to be tested and will participate in the comparison of results with specification sheet and the control of the TD's performance.

The test bench demonstrator will serve to demonstrate:

- the expected performances in line with UG requirement;
- that the interoperability rules and interfaces (FFFIS) are respected;
- the MMI concepts for GoA 2.

This is also the starting point of intensified, structured dialogue with authorities (ERA, NSAs) for to clarify all open requirements to liabilities in case of parallel operation to create an efficient process for authorisation.

#### **5.6.4. Freight ATO – GoA 2 Pilot Line Demonstration**

The aim of this task is to validate Autonomous Train Operation using a relevant pilot freight train and pilot line

- to perform statistical analysis on operation benefits comparing to the existing manually driven trains.
- to demonstrate the interoperability of GoA 2 solution.

This includes

- National preparation of testing methods, technologies and scenarios to validate reliable functioning in ATO testing environment
- Test preparation and performance jointly with technology suppliers, safety experts, RIU including connection to network control and timetable
- Evaluation of test results, definition and realisation of technical improvement



This activity is synchronized with TD 2.2.

#### **5.6.5. Freight ATO – GoA 4 Feasibility Study**

This task will demonstrate, theoretically, that the expected performances in GoA 4 could be achieved on the basis of ATO over ETCS and to identify the potential issues to address in the specification phase. This will include:

- The evaluation of the impact of the introduction of autonomous train operation on the competitiveness of freight rail transport
- the collection and the analysis of the corresponding Users Requirements;
- the identification of the hazards (PHA) of this innovative solution;
- a simplified model of system Architecture with the identification of all internal and external subsystems;
- a draft of system requirements specification.

This activity is synchronized with TD 2.2.

#### **5.6.6. Freight ATO – GoA4 Specification**

This aim of this task is to:

- review the ATO over ETCS specification (GoA 2) according the Operation Concepts updated according to the feasibility study.
- prepare the prototyping and testing phase on demonstrators.

It will include:

- the specification of operating procedures under GoA4;
- Prognosis of costs/benefits incl. impact on staff qualification;
- the definition of the mitigations for the hazards identified in the feasibility study, development of emergency and failure concepts including the fall-back levels optical signal detection and remote control;
- the specification of the system requirements, and overall architecture of ATO with obstacle detection considering also future extended functionality, e.g. automatic train preparation;
- specification of interfaces to external systems (e.g interlocking, TMS, maintenance systems) and further innovations planned, e.g. free float optimisation C-DAS (TD 5.5)
- Specification of obstacle detection requirements for detection of obstacles up to 1,000m ahead through advanced sensor technologies in order to comply with future standards for path monitoring and collision prevention



- Specification of on-board monitoring of critical components and intelligent self-surveillance for reliable system functioning (train integrity surveillance, smoke detection etc.) with a link to TD 5.1
- the functional requirements for tests to be executed

This activity is synchronized with TD 2.2. TD 5.6 will guarantee the compliance with operational rail freight concepts contribute to the specification to ensure that the freight operation will be fully taken into account.

#### **5.6.7. Freight ATO – GoA 4 Prototype Development**

The aim of this task is to develop prototypes in line with the ATO over ETCS interoperable system specification developed for the GoA 4.

ATO on-board and wayside technology will be developed for use on mainline freight locomotives (electric or Diesel/electric) to be interfaced interoperably with ETCS on-board units. Different architectures are planned by the manufacturers in TD 2.2. Implications on safety functionality for rail freight will be analysed and accordingly, prototypes of ATO on-board and track-side developed.

This activity is led by TD 2.2 with input from TD 5.6.

#### **5.6.8. Freight ATO – GoA 4 Test Bench Demonstration**

The aim of this activity is to develop test benches permitting to integrate prototypes from different suppliers.

It is required to perform test in order to demonstrate:

- The expected performances in line with UG requirement
- That the interoperability rules and interfaces (FFFIS) are respected;
- To validate the MMI concepts for GoA 4.

This activity is synchronized with TD 2.2.

#### **5.6.9. Freight ATO – GoA 4 Pilot Line Demonstration**

The aim of this task is to validate Autonomous Train Operation using a relevant pilot freight train and pilot line

- to perform statistical analysis on operation benefits comparing to the existing manually driven trains.
- to demonstrate the interoperability of GoA 4 solution.

This includes

- National preparation of testing methods, technologies and scenarios to validate reliable functioning in ATO testing environment

- Test preparation and performance jointly with technology suppliers, safety experts, RIU including connection to network control and timetable
- Evaluation of test results, definition and realisation of technical improvement

This activity is synchronized with TD 2.2. Additional contributions are expected from other rail freight operators to run an international demonstrator jointly.

### 5.5.7.6. Planning and budget

**Figure 107: Work breakdown scheme (tasks) for TD5.6, aligned to the structure of TD2.2**

Task No	Task	2014	2015	2016	2017	2018	2019	2020	2021	2022	2023	2024
1	IP2 - TD2 ATO Management											
2	ATO over ETCS - GOA2 Specification											
3	ATO over ETCS - GOA2 Product Development											
4	GOA2 Reference Test Bench Demonstration											
5	GOA2 Pilot Line Demonstration											
6	ATO over ETCS - GOA3/4 Feasibility Study											
7	ATO over ETCS - GOA3/4 Specification											
8	ATO over ETCS - GOA3/4 Product Development											
9	GOA3/4 Reference Test Bench Demonstration											
10	GOA3/4 Pilot Line Demonstration											

The estimated budget for the TD is around 5.7M€.

## 6. CCA – Cross Cutting Activities

### 6.1. Context and motivation

The performance of the railway system will only be improved if it is understood and managed as a whole system shared between many actors, with particular attention to the interfaces between the parts of the system.

To reach the ambitious goal, Shift2Rail must introduce novel and innovative technologies applied in each of the components of the system. Introducing new technologies at the component level and in different technology demonstrators (TDs) needs to be addressed not only at a vehicle/infrastructure level, but also at the complete railway system level, considering the different requirements, operational conditions and other aspects of the various application segments.

To implement this systems approach, the work conducted within the five IPs must be supported by cross-cutting themes proposing specific activities that are of relevance to several of the TDs across Shift2Rail, and that take into account the interactions between IPs and the different subsystems that have been defined. These cross-cutting activities (CCAs), organised around working areas, will also contribute to develop common methodologies across the JU.



## 6.2. Objectives and expected results of the CCA

The objective of the CCAs is to ensure that the R&I activities within the different IPs are closely aligned in terms of their objectives and requirements, as well as in terms of the methodologies to be used for evaluating and assessing the expected impacts. These activities include elements already taken into account in the different Innovation Programmes that require horizontal coordination, such as energy and noise management, safety, standardisation, overall traffic management, maintenance, virtual certification, as well as long term societal effects and human capital management. Furthermore, the CCAs will carry out the additional research needed to complement and leverage Shift2Rail's technical work.

The interactions between the different IPs will be of major importance, given that evolutions in technology in one part of the system managed by a specific actor, can lead to changes in performance or even create barriers that are visible in another part of the system managed by a different actor. In addition, cross-cutting activities will also include research on long-term economic and societal trends, such as customer needs, human capital and skills, which are necessary to be taken into account by the different Innovation Programmes.

The following table summarises the main objectives of the CCA and provides an overview of some of the concrete deliverables that can be expected to result from the activities undertaken in the CCA.

**Table 53: Objectives and challenges of the CCA**

Objective	Result	Practical (concrete) Challenge
<p>Railway system life cycle cost reduction</p> <p>Socio – economics: Bring an understanding on how rail can be a catalyst in transformational societal changes.</p>	<p>The added value of the WA is that it opens up the railway system to a wider audience with interest in mobility but disinterested in the modes.</p>	<p>The value of Shift2Rail lies in its capacity to address the challenge to enable a better accessibility and connectivity through the delivery of a high capacity and cost effective rail system seamlessly interconnected with other modes and embedded in a local, regional and cross border context.</p>
<p>Line capacity increase</p> <p>Operational reliability increase</p> <p>Railway system life circle cost reduction</p> <p>KPI and Integrated assessment – The objective of the Integrated Assessment (IA) is to show, that the results of the JU are fulfilling the expected results of the key Shift2Rail targets and the other expected benefits – in advance, during the project run time, and after the completion of the TDs' work.</p>	<p>Prognosis of KPIs at the beginning of the JU, as well as constant monitoring of the TDs' progress, and a comparison of the predicted outcomes against the demonstrated results</p>	<p>KPI development anticipates a huge added value for research in the railway sector and future projects is generated. It embodies a systematic approach to the understanding of the complex interrelations in railways, which will also be useful to forecast a project's costs and benefits.</p> <p>The deployment of the KPI tool for monitoring the IPs' and TDs' progress, enables continuous reporting and evaluation of the TDs' progress, their influence on the Shift2Rail goals and, if necessary, prioritisation of activities.</p>
<p>Line capacity increase</p> <p>Operational reliability increase</p> <p>Railway system life cycle cost reduction</p> <p>Enhanced Interoperability</p> <p>Safety, Standardisation, Smart Maintenance, Smart Materials &amp; Virtual certification</p>	<p>Safety: To develop a global approach of the safety of the railway system Quantify the safety improvements carried out in Shift2Rail TDs.</p>	<p>The safety remains the first priority of the railway transport but the complexity and the constraints become very high. The management of safety becomes a key issue to be addressed here.</p>
	<p>Standardisation: To transfer Shift2Rail results and outcomes of innovation activities into standards or normative documents.</p>	<p>Addressed Shift2Rail target is to remove remaining administrative and technical barriers, in particular by establishing a common approach to safety and interoperability rules to decrease costs.</p>

Objective	Result	Practical (concrete) Challenge
	<p>Smart Maintenance: The development of an overall maintenance concept taking into account all Smart Maintenance developments within Shift2Rail</p>	<p>Next to energy consumption, maintenance is the other driver of LCC. Lowering maintenance costs by using the new opportunities of knowledge about vehicle's conditions by digitalisation will have strong impact on reliability, availability and LCC and thus on attractiveness and competitiveness of rail traffic.</p>
	<p>Smart Materials: To explore the latest research in designing of smart materials and possibilities of applying various techniques and innovations in material science for railways.</p>	<p>Smart materials help in removing the boundaries between structural and functional materials, which may result in significant revolution in materials science development. It is a challenge for the railway sector to be on top of this development.</p>
	<p>Virtual certification: reduction of authorisation costs, facilitating cross-acceptance procedure, reduction of time and cost of (sub)- Systems Authorisation Process.</p>	<p>Proposal for mixed experimental/numerical authorisation processes, resulting in less on-site testing, more lab or vehicle testing and more simulations.</p> <p>Common authorisation procedures including standardised lab tests, vehicle tests, on-track tests and simulations procedures. Easier cross-acceptance process, by introduction of virtual testing.</p> <p>Development of harmonised rules for authorisation based on mixed experimental and numerical approaches.</p>
<p>Operational reliability increase Railway system life cycle cost reduction Smart Planning</p>	<p>Smart Mobility: To provide the basis for an open micro-level simulation, integrating planning activities and status information from the various actors within the railway system, (e.g. RU with their fleet and staff planning processes, IM whose assets are in a certain condition), to schedule planning and external parameters.</p>	<p>Enable railway stakeholders to make the best decisions for the overall system, for example concerning schedules and the availability of rolling stock and staff, based on up-to-date operational data, taking into account all essential information in order to ensure quality promised is delivered to customers.</p>

Objective	Result	Practical (concrete) Challenge
	Integrated Mobility Management I2M To specify, develop and integrate all necessary Elements into the Traffic Management System to integrate actual and forecasted Traffic Asset and Freight Operations status information into a seamless operation process	Challenge here addressed for Integrated mobility management is to be smart and based on a real-time seamless access to heterogeneous railway data sources (signalling data, maintenance plans, environmental conditions, fleet status, passengers requests and needs; etc.)
Environmental sustainability Energy Efficiency	Deliver a standardised methodology for estimation of energy consumption by simulation and a standardised methodology for measurement of energy consumption enabling the standardised specification of energy efficient railway systems	Reduce the operational costs through a reduction of energy consumption.
Environmental sustainability Noise and Vibration Control	Develop future methods for predicting overall noise and vibration performance on a system level including both rolling stock infrastructure and its environment Ensure that the N&V aspects are properly considered and integrated in all relevant Technology Demonstrators within the different Innovation Programmes of Shift2Rail	To reduce the annoyance and exposure to noise and vibration (N&V) related to the railway sector in Europe. This will enable an increase of traffic and enhance the attractiveness of the rail as mean of transportation
Operational reliability increase Human Capital	Increasing flexibility for both, employer and blue collar employees Making use of the benefits of digitisation and automation for job profiles and skills	Overcome the challenges imposed by demographic change and comprehensive and radical technological innovations

### 6.3. Past and ongoing European & national research projects

A number of projects funded by the EU in the last few years will give important input and starting reference points to the CCAs within Shift2Rail. Shift2Rail has here a potential to enhance the investment that European society has made in railway research in recent years.





Details on the projects are presented in the section devoted to each technology demonstrator, but some of the most relevant ones to the activity proposed in Shift2Rail are listed hereafter:

- **Noise and Vibration:** outcomes from European research projects Acoutrain (Virtual certification of acoustic performance for freight and passenger trains) and RIVAS (Railway Induced Vibration Abatement Solutions) about ground-borne vibration mitigation on open tracks
- **Energy:** RailEnergy (2006-2010) on electric and diesel Main Line trains energy reduction: Osiris (started on January 2012): This programme has many similar targets as RailEnergy but focus on urban railway systems
- **Safety:** Many European projects like TrioTrain, Acoutrain, Euraxles, Secret are dealing with the safety level of the components of the railway system. Safety and authorisation are closely linked together in these projects. For example, the OPENCROSS (“Open Platform for Evolutionary Authorisation of Safety-critical Systems”) FP7 project, which aims at developing the first European-wide open safety authorisation platform.
- **Standardisation:** examples include project BRIDGIT, or “Bridging the Gap between Research and Standardisation” to demonstrate that standardisation is a significant instrument for the dissemination of research results in a due time, as well as the market uptake of innovations. Also, the group STAIR or Integrated Approach for “STANDARDISATION, INNOVATION AND RESEARCH”, a group created to provide strategic advice to the CEN and CENELEC Technical Boards on the synchronisation of standardisation with innovation and research
- **KPIs:** Experiences from the work on the Technology Evaluator of Clean Sky can be used, in terms of methods for the definition and calculation of KPIs
- **Human capital:** EU FP7 projects FUTURAIL and SKILLRAIL, which have contributed to increase the knowledge on human capital in the railway sector

Finally, the Roll2Rail and In2Rail “lighthouse” H2020 projects, are orientated towards pre-starting some of the work lines of Shift2Rail. CCA areas included are Integrated Mobility Management and Energy in In2Rail as well as Noise in Roll2Rail. Results of Roll2Rail and In2Rail will be incorporated into the corresponding CCA area within the first 12-18 months after the start of Shift2Rail and will constitute an essential element towards the end result of the programme.

One or more members of Shift2Rail working within the CCA areas have participated in most of the earlier and ongoing EU projects, so the information flow and leverage from these will be automatically ensured.

## 6.4. Set-up and structure of the CCA

### 6.4.1. Structure

The S2R Master Plan identifies five cross-cutting themes that are of relevance to each of the different sub-systems and take into account the interactions between these sub-systems:

- Long-term needs and socio-economic research

- Smart materials and processes
- System integration, safety and interoperability
- Energy and sustainability
- Human capital

Additionally to these five work areas, the CCA will also cover the development of a common methodology for assessing the achievement of the Shift2Rail objectives (KPI work area).

Some of the work areas are composed of sub-work areas, as depicted in Figure 108.

**Figure 108: Work areas and Sub work areas in CCAs**

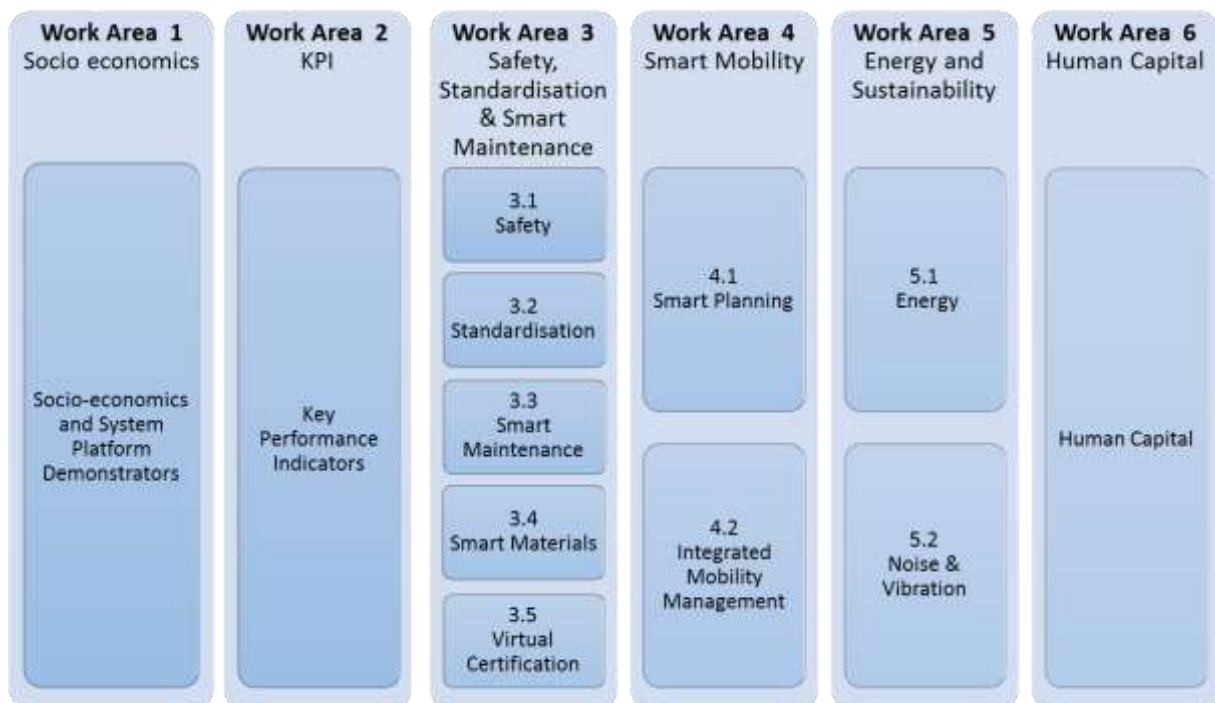

Detailed information on how each work area and sub-work area will address the objectives set in the Master Plan is described in Table 54.

**Table 54: CCA work content and relation to Master Plan**

Master Plan	Work Area	Sub Work Area	Aim and activity related to Master Plan
1. Long term needs and socio-economic research	1.Socio-eco & SPDs		Create knowledge of <b>success factors</b> for a future railway system based on <b>customer needs</b> and the <b>mobility behaviour</b> of users and better understanding of key trends, such as <b>urbanisation, demographic changes, ageing of society, hyper-connectivity, etc.</b> Definition of the <b>4 SPDs (System Platform Demonstrators)</b> : Freight, Urban, Regional and High Speed
	2.KPI		<b>KPI method development</b> and integrated assessment – Methodology for assessing the achievement of the Shift2Rail objectives (improved services for users and customer quality, reduced system costs, simplified business process and enhanced interoperability) and the contribution of the IPs and TDs.
2. Smart materials and processes 3. System Integration, safety and interoperability	3. Safety, Standardisation, Smart Maintenance and Smart Materials	3.1. Safety	Perform a <b>global approach of the safety</b> of the railway system Manage the safety level of the existing railway system, Quantify the <b>safety improvements</b> carried out in <b>Shift2Rail TDs</b>
		3.2. Standardisation	Coordinate and address <b>standardisation issues for all IP</b> to assure it is possible to meet overall S2R targets.
		3.3. Smart Maintenance	<b>Lowering maintenance costs</b> by using the new opportunities of <b>knowledge about vehicle's conditions by digitalisation</b> . This will have strong impact on reliability, availability and LCC and thus on attractiveness and competitiveness of rail traffic.
		3.4. Smart Materials	Study and <b>evaluate the maturity of smart materials</b> in other sectors e.g. nano materials, self-healing, adaptive, active materials. Propose possible <b>technology transfer</b> for applications in the railway sector .
		3.5. Virtual certification	A new methodology and tools to implement more virtual validation and authorisation of the components, sub-systems and systems Transfer of tests from on-track train testing to bench testing and simulations

Master Plan	Work Area	Sub Work Area	Aim and activity related to Master Plan
	4. Smart Mobility	4.1. Smart Planning	<b>Improve planning activities</b> of various stakeholders in the railway system by means of precise railway <b>simulation</b> . Its concept will cover all phases of railway planning and include an outlook on operation.
		4.2. I2M (Integrated Mobility Management)	Specification and Implementation of sub-structures needed for <b>automated message exchanges between Freight operations and Traffic management system</b> via the Integration Layer.
5. Energy and sustainability	5. Energy and sustainability	5.1. Energy	Achieve and assess the <b>overall energy reduction on all ITDs and SPDs</b> and demonstrate the <b>cost effectiveness energy saving</b> features Help and support all energy saving related work across the IPs and TDs Stimulate the emergence of pre-normative texts when needed to pave the way toward a European shared understanding of energy figures in railways. Link energy and sustainability actions with existing initiatives outside Shift2Rail in order to align understanding and positions from railways and energy stakeholders
		5.2. Noise	Develop future <b>methods for predicting overall noise and vibration performance on a system level, with a proper ranking</b> and characterisation of each contributing source so as to include different combinations of entire vehicles and infrastructure and optimise cost benefit scenarios as well as exposure and comfort. Ensure that the <b>NoV aspects are properly considered and integrated in all relevant Technology Demonstrators</b> within the different Innovation Programmes of Shift2Rail
6. Human Capital	6. Human Capital		Achieve a number of benefits and <b>overcome the challenges imposed by an aging workforce through:</b> <ul style="list-style-type: none"> <li>• <b>Increasing diversity</b> and flexibility for both, employer and (blue collar) employees</li> <li>• Healthier workforce because of the use of automated and robotic systems to <b>reduce the physical strain on humans</b></li> <li>• <b>Life-long development of new skills</b> and change in job profiles</li> </ul>

#### 6.4.2. Approach within the CCA

The CCAs have a dedicated organisation, with a CCA coordinator, and will work closely with the System Group to ensure coherence within Shift2Rail.

An intense cooperation with all the relevant IPs and TDs in the respective areas will be ensured, as illustrated above. This means that during the start-up of the project the purpose is to identify all

relevant components for each CCA area included in Shift2Rail TDs (Technical Demonstrators) and further to set and follow up targets for each contributor to achieve an optimal result on overall system levels. In addition the CCA part will develop methodologies to be able to properly address simulation of results on different TDs. Experts from CCA can also provide their know-how in many TDs and IPs especially to translate local Performance Indicators (PI) into the Shift2Rail macro indicator.

**Figure 109: CCA work areas give input and receive output from IPs**

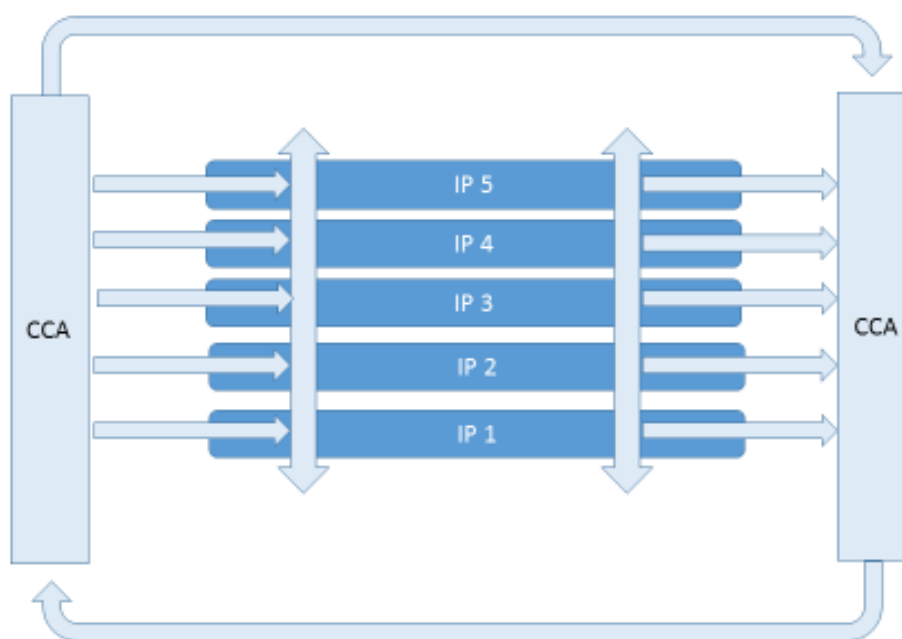

### 6.4.3. Involvement of Members in activities

The membership of the CCA of Shift2Rail includes all major European railway vehicle manufacturers, the principal companies for traffic management development, the two biggest train operators in Europe and two of the biggest infrastructure managers as well as an important research institute.

The type of work proposed in CCA covers a very wide range of competencies. Due to this varying but still highly specialised type of work, members will rely on the involvement of SMEs, research institutes and universities as essential to complete the work programme especially for all the methodology work that will be delivered by CCA. The open Calls budget of 40 % of total budget will allow involving these skills required along the project.



## 6.5. Work Areas of the CCA

### 6.5.1. Work Area 1 – Long-term needs and socio-economic research

#### 6.5.1.1. Concept and objectives

WA1 will assess the railways from an outside perspective and bring an understanding on how and in what extent rail can be a catalyst in transformational societal changes. The added value of WA1 is that it opens up the railway system to a wider audience with interest in mobility but disinterested in the modes. The future scoping of societal values, technological and behavioural trends and the assessment of how the railways can interact, respond and also be a driver of change is important for the investment in assets with such longevity as rail.

The rail system is not an end in itself but a means to support the development of an attractive sustainable society which is prosperous and cohesive. Free movement of goods and people accounts for two of the “four freedoms<sup>14</sup>” of the internal market. The value of Shift2Rail lies in its capacity to enable a better accessibility and connectivity through the delivery of a high capacity and cost effective rail system seamlessly interconnected with other modes and embedded in a local, regional and cross-border context. It is important to better understand in what way safe, reliable, comfortable train services can be beneficial for enlargements of regions and integration of major conurbations. The WA1 will analyse how society is influenced by the rail system in general but will also study in particular the areas and the expected improvements that the works deployed under Shift2Rail bring to the European context in terms of social and economic benefits.

WA1 will look at the rail system from the outside, and on it as a part-function in a much bigger societal and transport context.

#### **Strengthening the role of Rail in European Transport**

Today, figures from the railway sector show that in most countries around Europe there is a low level of railway usage in general (passenger and freight) with only limited changes and improvements during the last 20 years<sup>15</sup> (5-8% of railway usage for distances over 50km). But in some local areas and on improved lines railway usage is significantly higher than everywhere else, with the reasons for this being:

- Traffic limitations within cities (traffic jams, charging systems, parking restrictions, etc.)
- due to faster and better lines and services, combined with
- additional incentives

Sometimes railway systems are more successful than the existing physical possibilities (Paris, London, Munich, and connection like Copenhagen – Malmö, Paris – Marseille, and Frankfurt – Nuremberg,)

---

<sup>14</sup> four freedoms that underpin the European Union's internal market: the free movement of goods, labour, capital and services.

<sup>15</sup> compare Master Plan page 7: “Despite many positive developments in recent years, with growth in rail markets across many parts of Northern, Western and Central Europe, namely thanks to heavy investments for instance in high speed train infrastructure<sup>6</sup> and other innovative solutions, rail has still not succeeded in outpacing the road and air sectors.”



with the effect that lines are crowded and more or less uncomfortable. In this case of “crowded system” capacity improvements are necessary, with this being one of the main objectives of Shift2Rail. In all other cases, it requires a combination of different factors to fulfil passenger and freight needs in the future. Reduced costs and better reliability will be some of the key factors to improve the customer experience, but a lot of additional factors are relevant for customer behaviour. Today the knowledge about both key factors and customer behaviour is limited, and as a consequence the railway system does not fulfil the needs of more than 90% of mobility users in Europe.<sup>16</sup>

WA1 will deliver the knowledge of key success factors for a successful railway system based on customer needs (and not on technical possibilities of the railway system) in a changing world. One major trend is digitalisation. Digitalisation of society and economy will impact the way people live, work, consume and move. A new industrial revolution that rewrites the manuals on how products are being engineered, produced and marketed to end customers could significantly alter the supply chains, as well as human contacts, behaviour and interests. Macro changes in the global economy will influence trade patterns and travels, thus the goods being shipped and the mobility of passengers. Therefore Shift2Rail through the WA1 CCA needs to pave the way for the enhancements of the European Rail system by studying the societal and economic implications and preparing the necessary evolutions to cope with these macro changes.

### **Benefits of socio-economic studies**

The railway system is a service function in society. Its value resides within its societal functions. There is no value in rail traffic in itself, unless for scenic and touristic operations. On the other hand, the negative effects from rail and rail traffic must be more than balanced by societal values, and the perceived functions. Understanding the values and functions is a necessity for a successful JU. These areas have been thoroughly looked at and developed inside and outside European projects, and therefore WA1 can and will use these results for the Shift2Rail work.

As a result of WA 1 answers to the following questions will be obtained:

- What are the current and future expectations of the passenger in relation to door-to-door mobility, taking into account new societal trends, such as ageing society, digitalisation, new lifestyles, and cooperative economy?
- What are the obstacles for more passengers, for more goods on the train (based on a door-to-door mobility, including the planning phase)?
- What can be done by the railway system to overcome these obstacles? (examples: flexibility, train frequencies, access to the stations, mobility at the end destination, comfort of access vehicles to the stations)
- What the possibilities of the Railway Undertakings, the Infrastructure Managers (station/ lines) and the railway industry in general to support mobility from door-to-door and to enable future needs? (bring your bike, bring your e-vehicle, different activities within the trains, ...)

---

<sup>16</sup> compare Master Plan page 7: “From a customer perspective the quality of rail services continues to be perceived as insufficient.”



- What kind of cooperation with other mobility partners (busses, semi-/private cars, local managed mobility, etc.) will be necessary? (Common ticket system, flexible offers, 24/7 availability, etc.)

All activities within WA1 are based on 4 use cases

The use cases are the basis for the societal usage of the demonstrations/TDs.

These four use cases are based on the four global System Demonstrator Platforms (SPDs) defined within Shift2Rail which are:

- the High Speed and Mainline passenger demonstration platform
- the Regional passenger demonstration platform
- the Urban and Suburban passenger demonstration platform
- the Freight demonstration platform

They are specified here after.

#### Use case on long distance and higher speed rail

Railways can facilitate integration of regions and labour markets on a transnational EU level. Long distance commuting has been a major growth sector in many member states. This makes it possible for the citizens to live and work where it's most suitable. There is more to be done to align better the constituent elements of a journey with the needs of passengers: better coordination between modes and operators, improved information systems, improved connectional times and better access to rail are all deserving of further research. Cooperation between stakeholders on door to door travel chains together with better information systems, minimising delays and ensuring easier access to rail are some elements where research efforts can contribute to improvements for passengers and thus make rail a better travel option. Shift2Rail targets substantial improvements in capacity, infrastructure, traffic information and ticketing and rolling stock which taken together should support viable and customer oriented long distance and high speed traffic. How all these improvements will impact the societal values of long distance and high speed travel will be described.

#### Use case on regional traffic

Regional train services are often publically procured by regional governments to ensure their constituents basic mobility services. They enable social and territorial cohesion and balance and provide a means for people to commute to work, schools and easier access to specialised health care and cultural events. Regional trains often run on mixed traffic lines where they compete for capacity with freight trains. Logistics chains for heavy industries normally rely on trains for their supplies and export of their products. Shift2Rail capacity enhancing innovations that allow freight and passenger trains to better coexist on railway lines is the theme of this use case. The impact on regional development, competitiveness of industries will be described.

#### Use case on urban traffic

Shift2Rail operational targets are assessed in a use case involving a major European city. How punctuality, capacity and reliability improvements brought about by Shift2Rail is impacting the





business, social and cultural environment is described. A methodology is developed and used that can be inferable to other bigger cities, including real estate values, localisation of businesses and new residential areas.

### Use case on freight

Technological innovations that support efficient logistics solutions for transport of materials, steel, paper and consumer goods are key targets in the freight use case. Rail should be seamlessly integrated with other modes – road, maritime, through interchange nodes where transshipment takes place without unnecessary time losses and where added value service can be offered. Shift2Rail induced system benefits in the form of increased capacity, productivity and throughput accompanied by improved reliability, accuracy and lead times is assessed in a perspective where employment and competitiveness of the industry and society are key factors.

### Impact

The purpose of WA1 is to scope out future societal, behavioural and technological trends that influence mobility patterns and its possible implications for rail.

### Linkage and alignments with Master Plan

Table 55 shows the links between WA1 and the objectives of the Shift2Rail Master Plan

**Table 55: WA1 links to Master Plan objectives**

Master Plan objectives		Addressed by:
Improved services and customer quality	MP1 Improved reliability	<ul style="list-style-type: none"> <li>strengthening the role of rail in the European transport</li> <li>radically enhancing the attractiveness and competitiveness of the European railway system</li> <li>fulfilling rapidly evolving quality expectations of users and improving customer experience,</li> <li>operational reliability of the railway system</li> <li>improving capacity on crowded lines</li> <li>enhancing accessibility</li> <li>offering more transport and travel options in a more flexible manner</li> </ul>
	MP2 Enhancing capacity	
	MP3 Customer experience	
Reduced system costs	MP4 Lower investments costs	
	MP5 Reduced operating costs	
	MP6 Externalities	
Enhanced interoperability	MP7 Respect and adaptation of TSIs	
	MP8 Removal of open-points	
Simplified business processes	MP9 Improved standardisation	
	MP10 Simplified authorisation	



### **Relevant EU projects, national projects and past experience**

WA1 will build on results from many previous EU funded research projects of relevance to the works within this CCA. WA1 will build on the Shift2Rail perspective. Selections of some recent projects which connect to the proposed activities are listed below:

- **Public transportation – Accessibility for all** – to develop a prototype of a vehicle based boarding assistance system (for rail vehicle access)
- Interconnection between short and long-distance transport networks – to investigate factors such as integration, co-operation and competition in local connections across the different transport modes.
- **Public participation and urban transport innovation** – to analyse the mutual relations between tram revival and the emergence of participative democracy and passenger involvement in public transport
- **HERMES** – to develop, contribute with knowledge and analyse patterns of human mobility and the structural and organisational patterns that can be found at the interface between long journeys and shorter local / regional transport.
- **CROSSRAIL** – to contribute to the reduction of the environmental impact of traffic by promoting more environmentally friendly transport in urban areas
- **Gröna tåget (The Green Train)** – to generate knowledge for future high-speed adapted to Swedish/Nordic conditions (industry-wide railway research programme).

#### ***6.5.1.2. Implementation of the work programme***

The work breakdown scheme is depicted in Figure .

The innovative part of WA1 is to bring expertise normally not used in railway programmes, which most often have a technical or economic focus. This may lead us to reassess commonly held conventional wisdoms and thus bring new perspectives to mobility and rail as a mobility enabler. This may lead to a need for basic research in e.g. the behavioural sciences. The open calls will be necessary for bringing in external expertise, in a high degree from outside the traditional rail sector. This will bring in new perspectives and out-of-the-box thinking.

The work plan for WA1 is presented here after in Table 56, and the Gantt chart, in Figure 110.



**Figure 110: WA1 work breakdown structure**

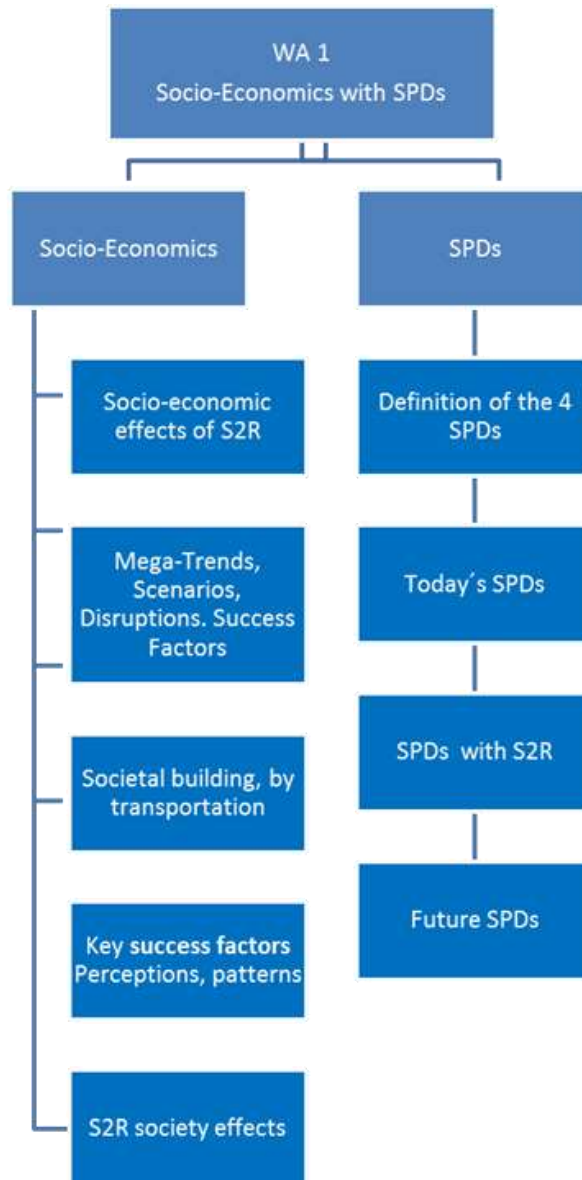

Table 56: WA1 task details

Task	Task Name	Task Description
WA1.0.1	Societal Needs Analysis	<p>For the wider society functions, the shortcomings in the rail system deliverables forms a gap. This, combined with other needs, must be systematically specified and analysed from the Shift2Rail system perspective in the complete societal transport system.</p> <ul style="list-style-type: none"> <li>• Greening of the society</li> <li>• Smart inclusive growth</li> <li>• Regional integration and enlargement for critical mass (labour markets, health care and education ...)</li> <li>• Competiveness and sustainability</li> <li>• Sustainable Seamless door to door mobility solutions</li> <li>• Liveable smart cities</li> <li>• Attractive, connected and accessible regions</li> <li>• Land use and spatial planning</li> </ul> <p>A close collaboration with WA 2 is necessary here.</p> <p><b>Open Call:</b> Collaboration call research centres with different backgrounds (economics, spatial planning, traffic planning, behavioural psychology in forming modal choices, society, etc.) should describe the influence of Shift2Rail effects related to the objectives of the Master Plan. In addition, they should develop on what could be done to accelerate and/or to intensify the effects.</p> <p>Example: Reduction of 10% individual motorised traffic will result in benefits:</p> <ul style="list-style-type: none"> <li>• for the society: more recovery areas, more communication between locals</li> <li>• for the environment:</li> <li>• for the vitality of a town</li> <li>• more attractive pedestrian and cycling areas which will strengthen the effects itself.</li> </ul>

Task	Task Name	Task Description
WA1.0.2	Influences to 2022, 2030, 2040 from Mega-Trends, Scenarios, Disruptions. Key Factors	<p>Every future system needs to be developed by taking into account the future challenges. The necessary foresight is never accurate, but must be able to see and cope with different developments. By having a structured approach, the adaptability of the societal functioning will be facilitated. This task will describe the circumstances for railway in 2020, 2030 and 2050. What will be the future landscape, challenges, needs of customers (passenger + freight) in 2020, 2030 and 2050? How do the TDs results fulfil the upcoming challenges?</p> <p><b>Open call:</b> The initiative needs different scenarios for changes related to mobility: digitisation, self-driving cars, electric cars, private organised transport, behaviour changes, etc. Does the current railway system provide the right answers?</p>
WA1.0.3	Societal building, by transportation	<p>Transportation has a major influence on the society and its function. Often a transport system is regarded passive factor affected by the selected society model, however a transport system can be used as an active factor for creating the wanted society. Thus, by using the transport system as a design tool for societal building, the desired effects can be strengthened. The Shift2Rail results will be put into a perspective where its achievements will be investigated as potential societal building stones. This work covers how societal trends are influencing the transport system and hence the railway system.</p>
WA1.0.4	Key success factors for a successful railway system. Perceptions, Mobility patterns	<p>Customer views, service levels and more efficient process are asked for. Socio-cultural context of railways and stations as gateways to cities will be studied, new patterns will probably increase these demands, and the evolution of demand for freight rail transport as a consequence of the innovation introduced by S2R, thus this must be included and evaluated in the societal models. The influence of the Shift2Rail innovations has to be taken into account here.</p> <p>What are the success factors for a Shift2Rail (passenger and freight)? What are the obstacles? Which one can be solved by the railway system, which one will need the cooperation with third parties? We want to develop this in a direction where we look at future preferences, values, perception of rail as something more than just a to b transport.</p> <p>This task will deliver the key factors for a successful railway system (passenger and freight) and will integrate customer views, service levels and more efficient process, together with a description of general and specific obstacles. Which ones can be solved by the railway system (technical/ non-technical solutions and approaches, where does the cooperation with third parties become essential? This requires a broader view knowing that rail mobility with does not start and end at a rail station. Results will include a research map, which shows possible measures for urban, regional, long-distance and freight transport that will attract more customers. This study will include reliability, costs and capacity measures.</p> <p><b>Open Call:</b> Collection of today's knowledge of influence factors for mobility behaviour. Which factors are already known, up to which level mobility behaviour can be explained, what are the unknown factors, which factors could have an influence on mobility? With the available knowledge, what would be a perfect system to get the most customers?</p>
WA1.0.5	Shift2Rail society effects	<p>Towards the end of the project duration, the Shift2Rail innovation results will be known. These results will be combined with the previous results in this WA, especially WA 1.0.1. The obtained and potential societal effects will be shown.</p>

Task	Task Name	Task Description
WA1.0.6	Societal definition of the 4 SPDs	Besides the SPD actions in WA2 for defining the SPDs for the KPI process, the four SPDs are the key storytelling for the wider understanding of what a Shift2Rail rail system will look like. It is not just the Shift2Rail result that will be shown, it is the rail system from the users and customers perspective that will be shown.
WA1.0.7	Today's SPDs	The SPDs have to be specified from the societal and functional view. As a basis, the present traffic segment must be described, in order to be able to prepare for the addition of the Shift2Rail achievements. Railway operation is constantly changing, this will be addressed here. The flexibility of the model, and an attention to changes stemming from the outside of Shift2Rail, is to be included. The strong link with WA2 is essential. .
WA1.0.8	SPDs with Shift2Rail	This is the complete view from the outside of the rail sector, of how the four SPD segments looks like with the Shift2Rail results. The TDs objectives and expectations are taken into account here. It should also show how the segments would have looked like without Shift2Rail. A limited mid-term view will be developed.
WA1.0.9	Future SPDs	The above descriptions will show shortcomings of the Shift2Rail work. It is necessary to draw conclusions about these shortcomings and how they can be handled.

6.5.1.3. Planning and budget

Figure 111: WA1 Gantt chart

WA1- Long-term needs and socio-economic research		2016				2017				2018				2019				2020				2021 - 2024			
Task	Description	Q1	Q2	Q3	Q4	Q1	Q2	Q3	Q4	Q1	Q2	Q3	Q4	Q1	Q2	Q3	Q4	Q1	Q2	Q3	Q4	Q1	Q2	Q3	Q4
WA1.0.1	Societal Needs Analysis																								
WA1.0.2	Influences to 2022, 2030, 2040 from Mega-Trends...																								
WA1.0.3	Societal building, by transportation																								
WA1.0.4	Key success factors for a successful railway system.																								
WA1.0.5	Shift2Rail society effects																								
WA1.0.6	Definition of the 4 SPDs																								
WA1.0.7	Today’s SPDs																								
WA1.0.8	SPDs with Shift2Rail																								
WA1.0.9	Future SPDs																								

The estimated total budget for WA1 is around 2.2 M€.



## **6.5.2. Work Area 2 – KPI method development and integrated assessment**

### **6.5.2.1. Concept and objectives**

A technology and impact evaluation is an essential element within Shift2Rail. The objective of Work Area 2 is to show, that the results of the JU are fulfilling the expected results of the key Shift2Rail targets – in advance, during the project run time, and after the completion of the TDs' work. This requires a prognosis of Key Performance Indicators (KPIs) at the beginning of the JU, as well as constant monitoring of the TDs' progress, and a comparison of the predicted outcomes against the demonstrated results.

The achievement of the Shift2Rail targets will be supported by regularly assessing the degree of target achievement for each TD. Furthermore, by setting up an integrated KPI model that shows interrelations, parameters that are crucial for the achievement of the objectives can be identified and help decision making on priorities for the JU.

In order to do that, the TDs' objectives have to be set in relation to KPIs of capacity, reliability and life cycle costs (LCC) and further in relation to the top-level objectives of Shift2Rail: improved services for users and customer quality, reduced system costs, simplified business process and enhanced interoperability

By analysing how every single TD contributes to Shift2Rail objectives, by defining which impact the TDs are obligated to achieve on low level KPIs and by regularly assessing the TDs' success in achieving their objectives the success of the whole JU is supported. In particular, a KPI model that shows all interrelations between all KPIs is to be set up. This includes contributions of individual technologies to the respective KPIs as well as inherent goal conflicts. The model should cover all systems including infrastructure, rolling stock and train operation, as well as intermediate performance indicators and finally all KPIs from the Master Plan.

As far as possible, the application of this model in the framework of Shift2Rail, in particular in terms of the determination of quantitative results, will be supported by tools. At this point, existing tools and models are to be investigated and complemented by new developments. At the end of the day, a KPI tool enables the effective implementation of the KPI methodology.

With this KPI tool, also a huge added value for research in the railway sector and future projects is generated. It embodies a systematic approach to the understanding of the complex interrelations in railways, which will also be useful to forecast a project's costs and benefits.

Finally, the deployment of the KPI tool for monitoring the IPs' and TDs' progress, enables continuous reporting and evaluation of the TDs' progress, their influence on the Shift2Rail goals and, if necessary, prioritisation of activities.

### **6.5.2.2. Impact**

The benefits from this Work Area (WA) comprise mainly of the monitoring and controlling of the overall Shift2Rail project's success. It allows the identification of key success factors among the high number of TDs and IPs and their objectives and thus supports the right prioritisation of activities in favour of the maximum outcome of each IP. However, the creation of a KPI model and KPI tool for



the railway system also represents an important contribution for railway research. Shift2Rail offers a unique chance for the analysis and validation of cause-and-effect chains within the railway system. Once the KPI model and tool will be validated, it offers multiple useful possibilities not only for the conception of future projects, but also for the research on effects of infrastructure or traffic measures. Furthermore, it provides a basis on which the individual stakeholders (railway undertakings, infrastructure managers, suppliers and so on) can generate and calculate their distinct business cases for the developed technologies.

### **Linkage and alignments with Master Plan**

Table 57 shows the links between WA2 and the objectives of the Shift2Rail Master Plan.

**Table 57: WA2 links to Master Plan objectives**

Master Plan objectives		Addressed by:
Improved services and customer quality	MP1 Improved reliability	<ul style="list-style-type: none"> <li>• setting TDs' objectives in relation to the Master Plan objectives</li> <li>• identifying key success factors and the respective TDs' objectives</li> <li>• monitoring the progress throughout the project run time and after completion</li> </ul>
	MP2 Enhancing capacity	
	MP3 Customer experience	
Reduced system costs	MP4 Lower investments costs	
	MP5 Reduced operating costs	
	MP6 Externalities	
Enhanced interoperability	MP7 Respect and adaptation of TSIs	
	MP8 Removal of open-points	
Simplified business processes	MP9 Improved standardisation	
	MP10 Simplified authorisation	

### **6.5.2.3. Implementation of the work programme**

The first outcome of WA2 will be the KPI model that shows all relevant KPIs, and their respective sub-KPIs on several levels, as well as primarily qualitative relationships between them. To achieve this, the TDs' objectives have to be collected first. At this point, results from WA1 regarding the TDs' benchmark scenarios will be integrated. Vice versa, findings from the KPI relations will contribute to the definition of the target scenarios in WA1.

**Figure 112: Information exchange between WA1 and WA2**

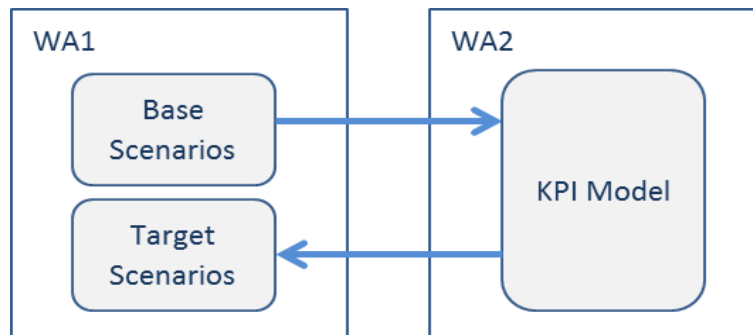

Another aspect is the structure of the railway system that has to be taken into account. From the TDs' contributions, as well as the railway system structure, all relevant KPIs on all levels of detail should be identifiable. Finally, the TDs' objectives, scenarios, railway system structure and Shift2Rail goals have to be aligned in order to obtain an integrated KPI structure from low to top level KPIs.

**Figure 113: Schematic representation of how the KPI model reflects the project structure**

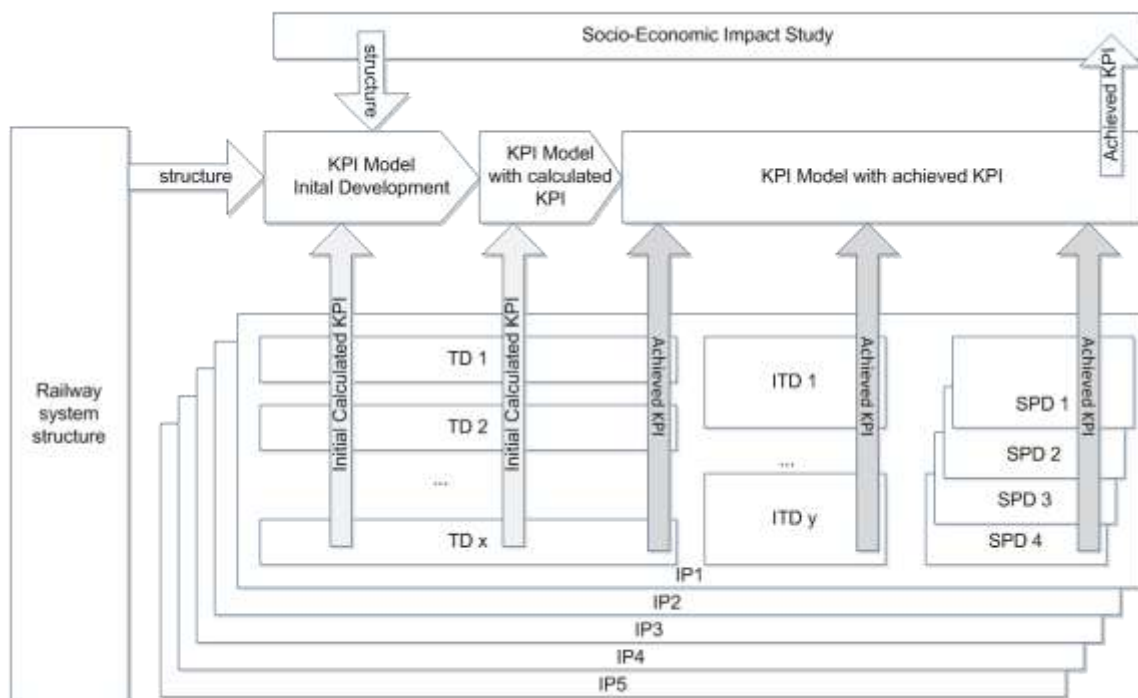

Based on the KPI model, tools can be chosen to support the processing of the TDs' inputs into their influence on the top level Shift2Rail goals, as well as goal conflicts among the technologies' contributions to the KPIs. Existing tools have to be identified and examined in terms of their suitability and validity. If the requirements are met, interfaces will be specified in order to integrate them into the KPI model. Finally, a KPI tool is developed. Presumably, not all relations can be covered by existing tools, so, where necessary, complementary tools should be developed to fill critical gaps. This requires thorough specification of the requirements of these tools. That means first, existing

tools have to be investigated in terms of their suitability and validity. If positive, they have to be integrated in the KPI model. Interfaces between the found tools have to be defined and created. The result of this should be a more or less comprehensive network of tools. This has to be analysed in terms of in which parts of the model complementary tools are missing. They have to be specified and finally developed according to the specific requirements.

The KPI tool accruing from the existing tools and further additions can finally be applied throughout the project runtime for the purpose of monitoring the progress and success. For this, achieved low level KPIs have to be collected regularly from the TDs, and, as soon as available, the same has to be done for ITDs and SPDs. As soon as the KPI model and tool is finished, the collected figures can be filled in and the resulting impact on the top level objectives has to be interpreted and documented. This will also allow a validation of the KPI model and KPI tool towards the end of the project by comparing the measured values from the SPDs to the forecasted impacts on top level KPIs (at least for those that are quantifiable). WA2 consists of two basic parts as shown below, the KPI model and its application in the framework of the Integrated Assessment.

**Figure 114: WA2 work breakdown structure**

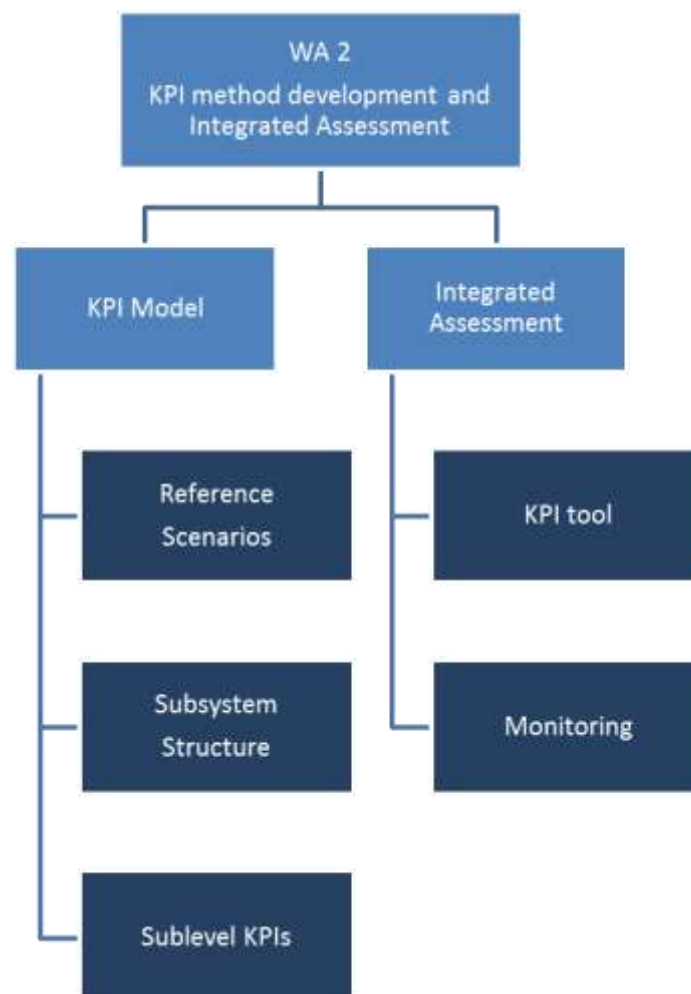



The most innovative part of the research in this Work Area will be the definition and determination of KPIs for the more qualitative objectives, such as for example attractiveness. Finding indicators to describe the level of attractiveness and parameters that influence it, or implementing “willingness to pay”-factors into the KPI model requires creative thinking and innovative tools. On the other hand, basic research oriented topics are especially the cost analyses. The method of Life Cycle Costing will be applied here on the railway system.

In order to allow for a continuous monitoring throughout the project duration, a major part of the KPI modelling and tool development has to be done at the very beginning. The first three tasks comprise the collection of data and information, and the alignment of all these findings into a KPI model. In parallel, tools for various relations can be identified and put together. Where necessary, gaps have to be filled by new tool developments that fit the needs of the overall KPI tool.

The work plan for WA2 is presented here after in Table 58, and the Gantt chart, in Figure 115.

**Table 58: WA2 task details**

Task Name		Task Description
WA2.0.1	Reference Scenario	<p>The goal of this task is to define the scenarios, in whose framework the current KPIs and the objectives of the Shift2Rail initiative will be compared. The reference scenarios are the benchmark for all further target descriptions. They have to be developed in consideration of the TDs objectives, the state of the art, the SPD definitions and the Master Plan objectives. All the necessary information has to be collected and analysed. In addition, the long-term technical strategy of the European railway system including operational concepts has to be defined. A close collaboration with WA1, in particular with their definition of the SPDs, is essential. The focus of the Reference Scenario Task in WA2 will be the interface to the WA1 and especially the alignment of their results with the KPI model. At the end of the day, the reference scenarios have to allow for all necessary sub and top level KPIs to be considered.</p> <p>Subtasks are:</p> <ul style="list-style-type: none"> <li>• Analysis of state of the art of European railway systems with regard to the top level KPIs</li> <li>• Analysis of state of the art of European railway systems with regard to the sublevel KPIs (task WA2.0.3)</li> <li>• Calibration of future scenarios (WA1) in terms of representability of all relevant KPIs</li> </ul>
WA2.0.2	Subsystem Structure	<p>The goal is to set up a hierarchy of the subsystems of railway operation.</p> <p>Railway operation is constituted by the functioning of different subsystem that interact, for example infrastructure, rolling stock and railway operation. Each of them consists of several sub-subsystems that will be analysed, and, if relevant for the KPI model, be modelled. Since some TDs concentrate on items on a very low level of these systems (for example door operation), it will be necessary to divide for example the rolling stock into a number of subsystems. In order to not only gain information on the impact of such sub-systemic innovations on the overall railway system, but also on the synthesis of several TDs, it is necessary to find an integrated subsystem structure that allows the representation of all considered innovation at the same time.</p> <p>Subtasks are:</p> <ul style="list-style-type: none"> <li>• Identification of relevant subsystems (based on TDs' contents)</li> <li>• Alignment of subsystems (originating from different TDs, it has to be analysed whether the ideas behind them are congruent)</li> <li>• Arranging the subsystems in a common context</li> <li>• Where possible, collecting data on the distribution of costs, reliability and capacity over relevant system structures</li> </ul>

Task Name		Task Description
WA2.0.3	Sublevel KPIs:	<p>A KPI hierarchy of all relevant KPIs is to be set up.</p> <p>Based on the system structure and an analysis of the TDs' targets, the low level KPIs will be defined and set in relation to the top level KPIs from the Master Plan. This task will be carried out in parallel to task WA2.0.2. Together, they constitute the KPI model. The challenges are similar to the subsystem structure: the ideas of different TDs as well as the requirements of the SPDs have to be arranged into a congruent system.</p> <p>The KPI models from Roll2Rail (WP 8) and IN2Rail (WP 7.3) will be taken into account. The models from the lighthouse projects are delivering modules of the entire KPI-model, which are integrated after evaluation. Further public accessible KPI models e.g. from standards (as e.g ISO 22400), handbooks and previous projects (as e.g. FP7 Automain or Clean Sky) will be used as input or reference.</p> <p>Subtasks are:</p> <ul style="list-style-type: none"> <li>• Identification of relevant KPIs (based on TDs' contents and external references)</li> <li>• Alignment of KPIs (originating from different TDs, it has to be analysed whether the ideas behind them are congruent or not)</li> <li>• Integration of KPI models from Roll<sup>2</sup>Rail and IN<sup>2</sup>Rail</li> <li>• Definition of complementary KPIs</li> <li>• Analysing the KPIs' interrelations (qualitatively)</li> <li>• Where possible, description of quantitative relations</li> <li>• Modelling</li> </ul>
WA2.0.4	Tool specification and development	<p>The goal is to build a KPI tool based on existing tools complemented, where necessary, by new tool developments.</p> <p>Existing tools and models for specific parts of the railway system will be identified and checked for their suitability. Where possible, interfaces between them will be defined in order to integrate them into the complete model. "White spots" will be identified and analysed in terms of the need for them to be filled. If a tool development is necessary, the requirements will be specified.</p> <p>The development itself will be subject to an open call.</p> <p>Subtasks are:</p> <ul style="list-style-type: none"> <li>• Investigating existing tools</li> <li>• Analysis in terms of validity, suitability</li> <li>• Identification of gaps, classification in terms of significance, identification of needs for tool development</li> <li>• Specification of requirements for tool development</li> <li>• Tool development</li> <li>• Overall integration in KPI model</li> </ul>

Task Name		Task Description
WA2.0.5	Validation of the KPI model	<p>The goal of this task is to validate the KPI model towards the end of the Shift2Rail initiative on the basis of the achieved KPIs. Before using the KPI model for monitoring there has to be a pre-validation of the sub-models as far as possible in order to ensure valid results.</p> <p>Towards the end of the project duration, the data from the demonstrations will be collected and used for validating the model. From potential deviations of the demonstrated or measured results from the prognoses at the beginning of the project, conclusions can be drawn about the quality of the KPI model and the KPI tool. Accordingly, improvements can be implemented.</p> <p>Subtasks are:</p> <ul style="list-style-type: none"> <li>• Pre-validation of sub-models before monitoring</li> <li>• Towards the end of the project: Collection of representative input data (KPIs) for achieved sub-level KPIs</li> <li>• Integration in KPI model and tool</li> <li>• Interpretation of results (comparison of prognoses and measured/ demonstrated results)</li> <li>• Improvements of the KPI model and KPI tool</li> </ul>
WA2.0.6	Monitoring	<p>The goal of this task is to monitor the progress of the TDs and IPs in terms of the achievement of the top level Shift2Rail goals.</p> <p>The achieved results will be compared to the set objectives for each TD throughout the project, thus monitoring the progress of the TDs and providing reports. On this basis, suggestions can be made where necessary as to where priorities may need to be shifted or objectives have to be refined.</p> <p>Parts of the continuous routine for the data collection from the TDs should be subject to an open call.</p> <p>Subtasks are:</p> <ul style="list-style-type: none"> <li>• Collection of TDs current status of goal achievement</li> <li>• Integration in KPI model and tool</li> <li>• Controlling and Reporting</li> </ul>

#### 6.5.2.4. Planning and budget

Figure 115: WA2 Gantt chart

WA2- KPI method development and integrated assessment		2016				2017				2018				2019				2020				2021 - 2024			
Task	Description	Q1	Q2	Q3	Q4	Q1	Q2	Q3	Q4	Q1	Q2	Q3	Q4	Q1	Q2	Q3	Q4	Q1	Q2	Q3	Q4	Q1	Q2	Q3	Q4
WA2.0.1	Reference scenario																								
WA2.0.2	Subsystem Structure																								
WA2.0.3	Sublevel KPIs																								
WA2.0.4	Tool sepcification and development																								
WA2.0.5	Validation of the KPI model																								
WA2.0.6	Monitoring																								

The estimated total budget for WA2 is around 1.9 M€.





### 6.5.3. CCA Work Area 3 – Safety, Standardisation, Smart Maintenance, Smart Materials & Virtual certification

#### 6.5.3.1. Sub-work area 3.1 Safety

##### Concept and objectives

Each railway company tries to optimise the processes and output of its production, maintaining at the same time a high safety level for all the activities involved.

More specifically, a transportation system can benefit from the safe production of transport services in the following areas:

- in the level of service offered to the users
- in the economic efficiency of the system
- in the environment surrounding the system

Furthermore, in what concerns the railway system, safety is one of the major inherent advantages over its main competitor (i.e. private cars), according to the official international accident records. In this context, a railway company needs to focus on safety in order to obtain a significant share in the transportation market. A good safety level makes the system more competitive and attractive to the users and thus contributes to the increase of its potential patronage.

The overall objective of WA3.1 is to develop a global approach of the safety of the railway system. The end result of this work is to provide to the infrastructure managers and operators (decision makers) an integrated management system for the safety of their railway system.

The term safety (risk) management includes the process which is followed, the means used and measures taken in order to achieve a specific goal related to the aspect of safety of the railway system.

Safety management encompasses the following issues:

- identification, assessment and ranking of risks.
- inclusion of all scientific “tools”, methodologies, relevant legislation and regulations, manpower, financial resources, equipment, technologies (TDs). Financial resources include money allocated by the infrastructure manager for the implementation of means/measures to improve safety, but also for equipment operation and maintenance.
- constructional and operational characteristics of the constituent and/or component for the measures to be taken

WA3.1 proposes a global approach of safety in the railway system. This global approach is based on a global risk assessment model, and will provide key results to reach the following objectives:

- manage the safety level of the existing railway system



- quantify the safety improvements carried out in Shift2Rail TDs

The safety level that a railway system provides to its users can be defined with the aid of the two following approaches:

1. Definition according to the risk level

This approach suggests a qualitative assessment of safety. In the case of a railway system the term “safety” describes the guarantee, through the constituents and the components of the railway system, that during operation the risk level is not described as “non-permissible” (European Standard EN50126). The classification of the risk is uniquely accrued by the combination of the frequency and the severity of an event. This correlation defines four risk levels (non-permissible, non-desirable, permissible and unimportant). In order to classify the various accidents according to the severity of their consequences, CENELEC European Standards adopt specific definitions (catastrophic, severe etc.). However, as far as accident frequency is concerned, there are as yet no European standards clearly defining the borderlines between the various classifications (possible, occasional, etc).

Based on this definition improvement of the safety level can be reached either by reducing the probability of having an accident, or by reducing the consequences of the accidents, or a combination of both. The aim is to assist towards the qualitative improvement of the initial risk level.

2. Definition according to incident “indicators”

This approach suggests a quantitative assessment of safety. The safety that a railway system provides is evaluated by the incidents that occurred during a specific time period (e.g. one year) and had consequences on the track, the rolling stock, the passengers, the cargo and the environment. In this context, indicators based on incidents that have occurred over a given time period are being used (ERA). These indicators are necessary for further decisions on prevention measures that need to be adopted.

Based on this definition improvement of the safety can be reached by changing the value of the accident indicators. The aim is that the measures addressing incidents should assist towards the reduction of the selected accident’s quantification indicator.



### Linkage and alignments with Master Plan

Table 59 shows the links between WA3.1 and the objectives of the Shift2Rail Master Plan.

**Table 59: WA3.1 links to Master Plan objectives**

Master Plan objectives		Addressed by:
Improved services and customer quality	MP1 Improved reliability	Considering the global approach of the safety level, the following tasks fulfil all the Master Plan objectives. Management of a safety level according to the risk assessment model (including unlocking of safety barriers) Quantification of safety improvements by using a risk assessment model
	MP2 Enhancing capacity	
	MP3 Customer experience	
Reduced system costs	MP4 Lower investments costs	
	MP5 Reduced operating costs	
	MP6 Externalities	
Enhanced interoperability	MP7 Respect and adaptation of TSIs	
	MP8 Removal of open-points	
Simplified business processes	MP9 Improved standardisation	
	MP10 Simplified authorisation	

### Relevant EU projects, national projects and past experience

Many European projects like TrioTrain, Acoutrain, Euraxles and Secret deal with the safety level of the components of the railway system. Safety and authorisation are closely linked together in these projects. For example, the OPENCROSS (Open Platform for Evolutionary **A**uthorisation **O**f Safety-critical **S**ystems) FP7 project aims to produce the first European-wide open safety authorisation platform. The purpose of the platform is to reduce time and cost for (re)authorisation of safety-critical embedded systems, in particular for the railway, avionics and automotive markets. OPENCROSS objective was to devise a common authorisation framework that spans different vertical markets for railway, avionics and automotive industries.

### Implementation of the work programme

In the context of Shift2Rail, the safety level carried out in each Technical Demonstrator will be assessed. This global approach will be also able to evaluate the impact of new equipment integrated in the existing railway system.

The most innovative part of this work is that the global approach is used to select the most efficient “everyday tasks” to guarantee a given level of safety. This scale shift must be specified in a collaborative project to be efficiently applied later.

The area foreseen for open calls concerns task WA3.1.3 in the application of the global assessment method. The work should focus on experiments based on requirements issuing from this work. They can also be associated to task WA3.1.1 to contribute to the state of the art.

The work plan for WA3.1 is presented hereafter in Table 60 and the Gantt chart, in Figure 116.

**Table 60: WA3.1 task details**

Task	Task Name	Task Description
WA3.1.1	State of the art of risk assessment methods	<p>Production of a state of the art on methods used in the railway domain and also in other domains.</p> <ul style="list-style-type: none"> <li>• Definition and types of railway incidents (for example accidents, events, failures)</li> <li>• Definition and categories/subcategories of railway incidents (for example derailments, collisions, accidents at level railway crossings)</li> <li>• Definition of causes of accidents in different levels (constituents, components, system operation)</li> <li>• Mitigation measures (in the level of constituents, components, operation procedures)</li> <li>• Best practices for the definition of the railway safety (for example according to incident “indicators or according to the risk level)</li> <li>• Best practices in terms of global safety management</li> <li>• Definition of the criteria to evaluate the result of the global railway safety management (quantify and evaluate the safety improvements carried out in Shift2Rail TDs)</li> </ul>
WA3.1.2	Requirements to conduct a risk assessment study on the overall railway system	<p>Define the requirements to develop the global approach, including.</p> <ul style="list-style-type: none"> <li>• a unique definition for railway safety- unified safety indicators</li> <li>• an integrated system for recording and monitoring the railway incidents</li> <li>• appropriate prediction models of the number of accidents</li> <li>• setting criteria to evaluate the result of the global railway safety management</li> <li>• a methodology allowing the correlation between the cost which is required for the application of preventive and mitigation measures dealing with accidents which occur within a railway system and the improvement of the level of safety as a result from their implementation.</li> <li>• definition of the values of each frequency and severity category, for each incident and cause category.</li> </ul> <p>The quantification of frequency is a topic that remains under research. Various European studies have attempted to classify an accident’s severity while as the EU, through the Standards Committee, has introduced a common ground of reference for these efforts</p> <p>The risk assessment method will be discussed but also the input data which is a key issue.</p>





### **6.5.3.2. Sub-work area 3.2 Standardisation**

#### **Concept and objectives**

In the context of improving Europe's competitive performance through innovation, there are close links between standardisation and research.

The main objective of WA3.2 is to transfer Shift2Rail results and outcomes of innovation activities into standards or normative documents,

- preventing overlaps and providing a coordinated approach towards future standardisation of S2R technical results
- ensuring standards of high quality with a high level of safety
- and helping to close TSI open points thanks to a coordinated work with ERA

WA3.2 aims also at proposing processes improvements, and at enabling the fast and easy transfer of research results to the European market.

WA3.2 plans on:

- advising on the most suitable standardisation strategy for the project and defining liaison with CEN and new fast processes
- ensuring methodological robustness and select the best state of the art
- enhancing the synergies and coordination between CEN / CENELEC/ETSI and Shift2Rail
- determining the standardisation potential of research results jointly with project partners
- assisting or facilitating the standardisation process, e. g. providing support to researchers on standardisation principles
- establishing innovative and time efficient mechanisms and processes to foster future standardisation of Shift2Rail results, including dissemination and allowing reduced time to market
- shaping the framework conditions of new and emerging markets

The end result of this WA has the following added value:

- new fast and easy processes
- production of new set of innovative technology standards
- taking part to the continuous improvement of recent links between research and standardisation

A particular attention will be given to interfaces between the parts of the rail system managed by the different IPs. WA3.2 will allow identifying any unnecessary duplications, reduce negative cross IPs impacts and increase the overall safety system.



A core focus of the activities will be on providing standardised specifications and on increasing harmonisation of operational rules and procedures with a view to ensuring that products could be placed on the market for use in several Member States eliminating cross-border operational constraints. A harmonised set of specifications on standardised interfaces and operational rules will contribute to an optimisation of the production with increased economies of scale and the delivery of components more easily interchangeable and deployable throughout Europe.

Shift2Rail activities will also trigger safety improvements through technology that would lead to the identification of the revision of safety rules and standards.

### **Impact**

This standard focused harmonisation process across IPs will generate **interoperable products and processes** and give access to a **broader base of mass production suppliers of standard technology**, cost effective and lead to sustainability efficient rail system attractive to end users whilst maintaining a very high level of safety performance.

Standards focused on a **plug & play approach** will be promoted.

The WA3.2 will monitor and address through its activities **the TSI open points**, in continuous cooperation with the European Railway Agency.

The Shift2Rail activities will in general affect technical standardisation and regulation in the following way:

- contributing to closing existing TSI open points
- contribute to improve existing standard TSI
- create new standard or regulation based on the outcome of disruptive technology innovation



### Alignments with Master Plan

Table 61 shows the links between WA3.2 and the objectives of the Shift2Rail Master Plan.

**Table 61: WA3.2 links to Master Plan objectives**

Master Plan objectives		Addressed by:
Improved services and customer quality	Improved reliability	<ul style="list-style-type: none"> <li>• Incorporating the standardisation perspective from the beginning of the activities</li> <li>• Simplifying and improving the standardisation process itself</li> <li>• Setting new standards in relation with master plan objectives</li> <li>• Identifying harmonised products, components and processes to be standardised</li> </ul>
	Enhancing capacity	
	Customer experience	
Reduced system costs	Lower investments costs	
	Reduced operating costs	
	Externalities	
Enhanced interoperability	Respect and adaptation of TSIs	
	Removal of open-points	
Simplified business processes	Improved standardisation	
	Simplified authorisation	

### Relevant EU projects, national projects and past experience

The structure and processes to be implemented will take into account CEN-CENELEC studies:

“**BRIDGIT – Bridging the Gap between Research and Standardisation**” to demonstrate that standardisation is a significant instrument for the dissemination of research results in a due time, as well as the market uptake of innovations.

### Implementation of the work programme

The activities will be undertaken in close relation with national standardisation bodies and European ones, like CEN-CENELEC and ETSI. ERA will also be an essential contributor for regulation matters.

The work plan for WA3.2 is presented here after in Table 62 and the Gantt chart, in Figure 117.



**Table 62: WA3.2 task details**

Task	Task Name	Task Description
WA3.2.1	Creation of a technical unit providing market-driven technology oriented activities	<p>This technical unit will be responsible for monitoring Shift2Rail's input to standardisation:</p> <ul style="list-style-type: none"> <li>• implement the adapted processes for standardisation of Shift2Rail results,</li> <li>• ensure the process is adhered to,</li> <li>• manage the appropriate interfaces with CEN-CENELEC-ETSI,</li> <li>• liaise standardisation actions between the overall IPs and TDs,</li> <li>• create a standardisation action plan for the work to be carried out and facilitate the work with the agreed time schedule,</li> <li>• contribute to standards drafts in accordance to CEN template and rules</li> <li>• ensure the good quality of the documents,</li> <li>• monitor the approval procedure of the project standards</li> </ul>
WA3.2.2	Benchmark of existing organisation and processes of innovative standardisation	<ul style="list-style-type: none"> <li>• Selection of the best practices and organisation in order to adapt them to railway needs and improve the current processes</li> </ul>
WA3.2.3	Establishment of the Shift2Rail internal standardisation processes	<ul style="list-style-type: none"> <li>• Selection and adaptation of the best practices and organisation derived from the benchmark</li> <li>• Shift2Rail internal communication of the standardisation rules (<i>role &amp; responsibilities of TDs/IPs leaders and internal process</i>)</li> </ul>

Task	Task Name	Task Description
WA3.2.4	Creation of the working plan	<ul style="list-style-type: none"> <li>• Liaise with TD Leaders to receive projects' results which may contribute to the preparation of European standards</li> <li>• Shift2Rail standardisation technical unit will propose a new work item to CEN/CENELEC/ETSI taking into account the existing standards (no duplication, manage the interfaces...),</li> <li>• Registration of new work items into CEN database,</li> <li>• Identification of European standards to be revised and revision monitoring</li> </ul>
WA3.2.5	Preparation of work items	<ul style="list-style-type: none"> <li>• In cooperation with TD Leaders preparing the scope of the future standards, when the items are highly mature</li> <li>• In cooperation with ERA ensuring that the safety requirements are in line with TSI</li> <li>• work closely with ERA to comply with interoperability requirements and closing open points</li> <li>• helping in ensuring conformity with prEN template</li> <li>• ensuring that the project results could be launched for approval in a quick CEN/CENELEC/ETSI process</li> </ul>
WA3.2.6	Work plan follow up	<ul style="list-style-type: none"> <li>• Monitor the formal approval of the project standards in due time (fast procedure)</li> <li>• Obtaining state-of-the-art information on standards that are available or that are under development, to ensure that results of research projects can make valuable contribution to the revision of standards</li> </ul>





### **6.5.3.3. Sub-work area 3.3 Smart Maintenance**

#### **Concept and objectives**

Next to energy consumption, maintenance is the other driver of LCC.

The current maintenance system is characterised by a combination of

- scheduled pre-emptive maintenance (preventative maintenance with service activities at defined intervals and replacement / reconditioning of parts before they fail) and
- unscheduled maintenance (corrective maintenance with repair / replacement of parts that have failed).

To make significant progress on lowering maintenance-related LCC, a new approach is required, since further savings through conventional means will only be possible on a small scale.

Yet, the introduction of digitalisation presents significant opportunities for reducing maintenance costs, while also having a strong positive impact on reliability and availability.

Diagnostics systems have been used in rail vehicles for many years, including remote data transmission systems for high-speed traffic. Modern vehicles are equipped with on-board diagnostics systems that continuously generate operational data. Such technical solutions already improve the ability to monitor and diagnose components in the vehicle's drive systems and running gear.

This monitoring of vehicle systems and vehicle components enables an evolution towards condition-based maintenance. However, at present, event data, log files and process data are not yet being analysed with the aim of establishing the condition of the subsystem.

The future lies in developing a Condition-Based Maintenance system (CBM), not only for vehicles but also for stationary components of the railway system. Diagnostics in the individual subsystems will utilise process parameters from existing sensors that are required for control purposes (e.g. "remote transmission of diagnostics data").

CBM offers important potential to achieve cost reductions, as it enables components to be used for practically their entire service life, while enabling improved planning and coordination of maintenance measures, e.g. joint scheduling of cleaning or maintenance activities of vehicles at the depot. The incorporation of automated condition-monitoring and analysis systems therefore enables re-optimisation of total maintenance costs (comprising preventive, corrective and condition-based maintenance operations).

The implementation of CBM requires new information and communication technology concepts for:

- Collection of diagnostic data within the vehicle and within stationary components
- Transfer the data to a central stationary IT-Server
- Development of diagnostic software for CBM for the maintenance shops



Modern vehicles and stationary components are already equipped with diagnosis systems that can be used and are capable of gathering huge volumes of various data.

These data present an important value potential for:

- Maintenance policies: for faults prevention (early detection,...) and troubleshooting;
- Asset Management policies, as it gives the opportunity to adapt and optimise maintenance policies to each individual asset (thanks to a clear knowledge of their real-life behaviour) (See TD3.8 from IP3)

However, so far, these monitoring systems have been implemented in an independent way, and this has had an influence on the way operators have made use of their potential: separately and without any system point of view. Yet, the data from one subsystem often contains huge amounts of relevant information regarding other parts of the Railway System, e.g.:

- rolling stock monitoring data contains information about infrastructure components state of degradation (signalling, energy distribution) and level of solicitation (train speed, ...)
- infrastructure monitoring data contains information about rolling stock state of degradation (wheels defects, axle loadings, ...) (See TD3.7 from IP3)

In addition, operating trains (including commercial – freight / passengers – and others) should be considered as “data gathering contributors” for future needs of data for rolling stock and infrastructure maintenance:

- With new existing monitoring means (smart sensors, on-line data processing, video camera, infra-red camera, 3D laser, thermal sensors, ...) and future technologies (unknown at the moment as these could be developed based on “internet of objects” approach)
- New kind of data type (video, pictures, 3D-clouds of points, ...)

WA 3.3 will seek to define the criteria applicable for condition assessment in order to enable condition-based monitoring for both safety and non-safety-relevant maintenance actions. The corresponding data sampling and assessment requirements will also be described, as well as the organisational aspects, like in which format and how often the transmission of diagnostic data has to be performed.

The activities in WA3.3 will be divided into three topics, each with specific objectives:

- smart maintenance concept
- rolling stock smart maintenance
- integrated infrastructure & rail-vehicle data management for smart maintenances



Within the smart maintenance concept topic the identified objectives are:

- development of an overall maintenance concept taking into account all smart maintenance developments within Shift2Rail (e.g. TD3.6 and 3.7 for infrastructure as well as TD5.1 for freight locomotives and wagons)
- R&D activities for condition-based maintenance (CBM) for passenger trains
- integration of concepts for monitoring of infrastructure by vehicles and vice versa

In the case of rolling stock smart maintenance the focus lies on further developing the maintenance system for case “Vehicle monitors itself” concerning passenger trains. In order to avoid special software and hardware development for each vehicle platform and entity in charge of maintenance the main objective of this topic is the standardisation of the data structures in cooperation with WA 3.6 (Dynamic railway information management system demonstrator) and WA 4.2 (I2M).

For integrated infrastructure & rail-vehicle data management for smart maintenances the aim is

- to facilitate the share of monitoring data between IP1 and IP3. This transversal task will generate benefits for:
  - intelligent maintenance TDs (Rolling Stock and Infrastructure)
  - design TDs which includes embedded monitoring devices Design (On-board and Wayside)
- to define **standards** concerning in/outputs and related to:
  - physical interfaces (electric power, voltage, plug compatibility),
  - data flow and format,
  - physical data transmission infrastructure
  - on-board rolling stock software and databases

These **standards** must allow connecting and using any kind of existing/new/future monitoring means and gather any kind of existing/new/future data type. These standards must be implementable in the case of existing and new rolling stocks.

- to facilitate innovative data analysis and modelling approaches dissemination into IP1 and IP3 datacentre activities (e.g. TD 3.6). This includes also the need of collaboration on this topic between these 2 IPs.

### **Expeted Impacts**

Benefits regarding the rolling stock smart maintenance sector of the topic include:

- increased vehicle availability as vehicles are not dispatched to maintenance depots unnecessarily
- reduction of maintenance costs up to 30%
- reduced down times by up to 50%



- less corrective maintenance when faults are identified before a fault occurs
- information for decisions on what, when and where repairs are to be carried out
- determining and analysing the root causes and underlying responsibility issues
- paradigm shift to condition-based maintenance
- condition analysis, component-lifetime predictions
- modifications to VIM (catalogue of maintenance tasks) and BIM (operator's maintenance tasks).
- optimisation of decision-making processes in traffic planning and traffic operations

Among others, an important end result of this area is a significant contribution to the CEN TC 256 WG 48 Rolling Stock Maintenance concerning creation and modification of maintenance plans. The modified maintenance plan fulfils all requirements on safety and usefulness.

Concerning integrated infrastructure & rail-vehicle data management for smart maintenances benefits include:

- cost and capacity: increased infrastructure availability, as a decrease of rolling stock and infrastructure curative maintenance is expected
- contribution to the reduction of operating costs
- sound decision-making for operational procedures
- improvement of maintenance policies: objectives of condition and risks based maintenance (CBM and RBM) for Rail/Rolling Stock interface assets
- condition analysis, component-lifetime predictions
- improved decision-making processes in maintenance planning



### Linkage and alignments with Master Plan

Table 63 shows the links between WA3.3 and the objectives of the Shift2Rail Master Plan.

**Table 63: WA3.3 links to Master Plan objectives**

Master Plan objectives		Addressed by:
Improved services and customer quality	MP1 Improved reliability	<ul style="list-style-type: none"> <li>• CBM increases the reliability and reduces the maintenance costs</li> <li>• setting TDs objectives in relation to the Master Plan objectives</li> <li>• identifying key success factors and the respective TDs objectives</li> <li>• monitoring the progress throughout the project run time and after completion</li> </ul>
	MP2 Enhancing capacity	
Reduced system costs	MP4 Lower investments costs	
	MP5 Reduced operating costs	

### Relevant EU projects, national projects and past experience

The work is based on the following former EU research projects:

- **SMART RAIL:** Life cycle assessment tool and findings regarding modern technologies
- **OPTIRAIL:** Development of a comprehensive tool, based on fuzzy and computational intelligent techniques, to manage all the elements that are relevant for track maintenance, predicting future conservations needs with optimal allocations of resources
- **AUTOMAIN:** Demonstration of advanced monitoring; decision support tool for maintenance
- **CAPACITY4RAIL:** Recommendations for Open-Source and Open-Interface for advanced railway monitoring applications

### Implementation of the work programme

There are four strategic areas of condition-based maintenance and each area will require collaboration with work conducted in the TDs of other IPs, as illustrated in Figure 118:

- infrastructure monitors itself (developed within TD 3.6, 3.7 and 3.8)
- vehicle monitors itself (developed for freight locomotives and waggons within TD 5.1 and for passenger trains within WA 3.3)
- vehicle monitors infrastructure (developed within TD 3.7 and this WA)



- infrastructure monitors vehicle (developed within TD 3.7 and this WA)

**Figure 118: Application fields of Smart Maintenance for railway undertakings and infrastructure managers**

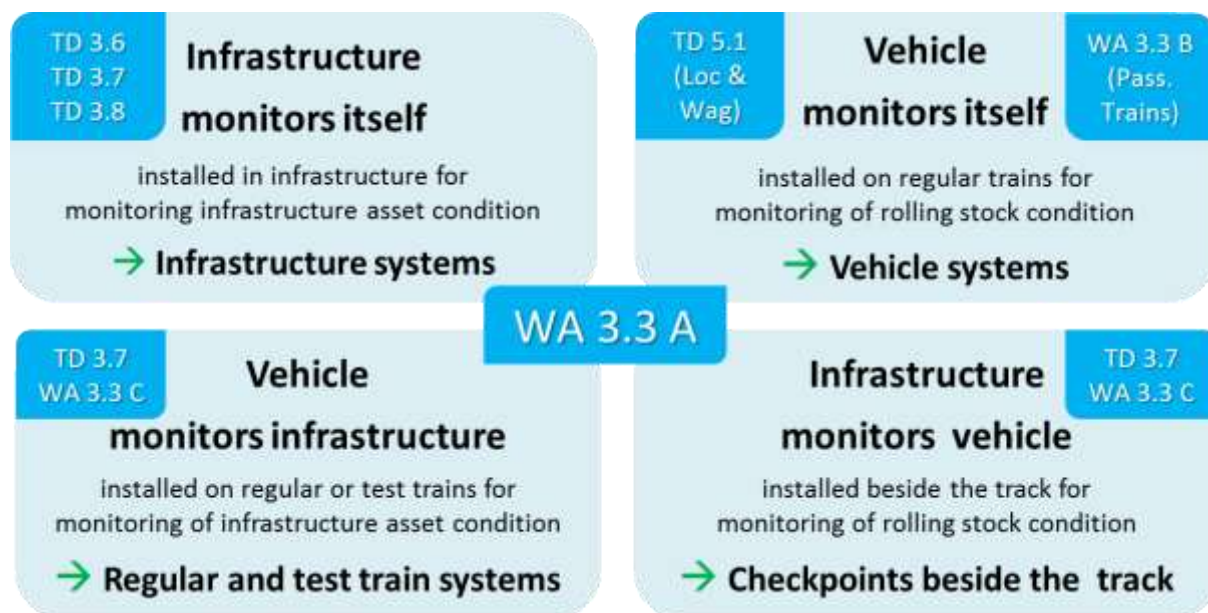

Analysis of data and recognition of hidden patterns in order to use them for the further development of maintenance guidelines will be performed as well as conversion of the findings into recommendations for maintenance.

Resolving basic questions regarding provision of data, methods of analysis and usage of results to optimise maintenance is a further goal.

Work will demand a strong collaboration between rail operators, infrastructure managers, assets and/or components manufacturers and engineering firms, and the piloting of data flows, results and application ranges in interaction of all involved parties will also be performed in the project.

During the project special attention will be given to the interplay of the defined functions of the entity in charge of maintenance (ECM) according Railway Safety Directive 2008/110/EC.

**Figure 119: Basic procedure to integrate automated condition monitoring data into the maintenance process**

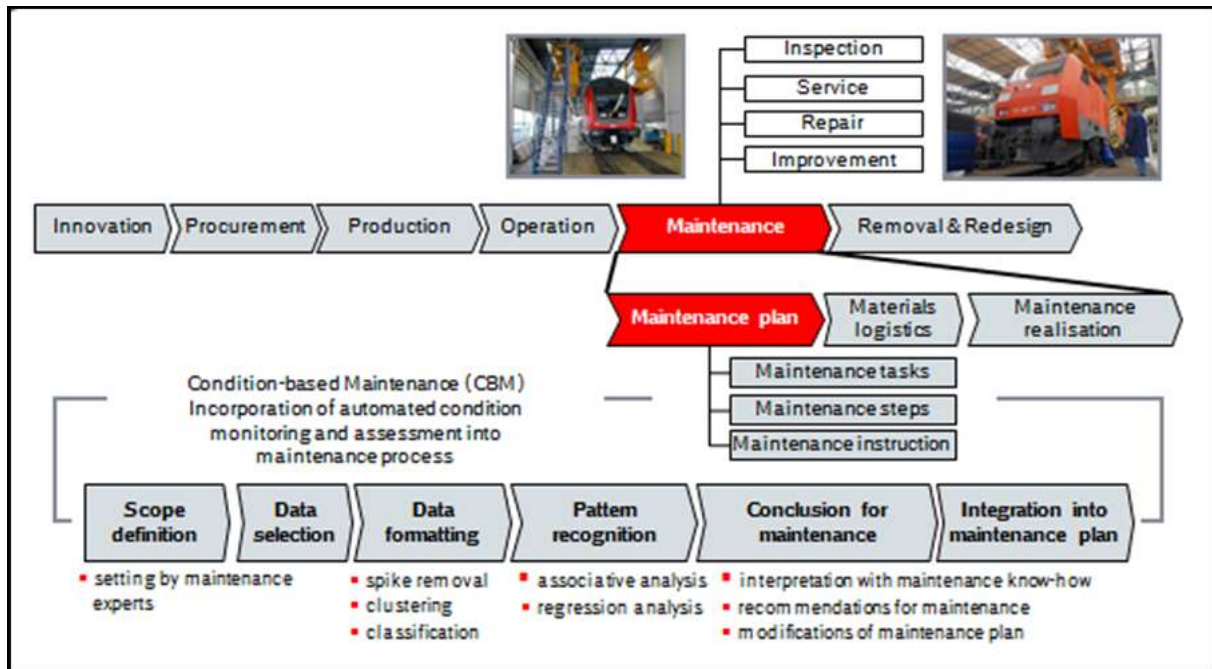

The work plan for WA3.3 is presented here after in Table 64 and the Gantt chart, in Figure 120.

**Table 64: WA3.3 task details**

Task	Task Name	Task Description
WA3.3.1	Scope definition	<p>The goal of this task is to define the scope of the WA in cooperation with other Smart Maintenance activities within S2R- Identification of activities within the TDs of S2R with respect to Smart Maintenance</p> <ul style="list-style-type: none"> <li>• vehicles to be considered (locos, EMUs, DMUs, wagons) in conjunction with IP 5</li> <li>• infrastructure components to be considered in conjunction with IP 3</li> <li>• maintenance task of priority</li> <li>• indicators and data sources</li> <li>• preparation and structuring of prediction-relevant data by fleet monitoring team</li> </ul>
WA3.3.2	CBM maintenance concepts	<p>The goal of this task is the development of an overall maintenance concept taking into account all CBM activities within S2R as well as the monitoring of infrastructure by vehicles and vice versa, e.g.</p> <ul style="list-style-type: none"> <li>• development of a new mutual approach (big data, cross data sources, use of connected objects), which will be studied in direct coordination with all tasks of WA 3.3</li> <li>• definition of the interfaces between rolling stock and maintenance.</li> <li>• definition of the interfaces between measurement benches fitted on the ground and maintenance.</li> <li>• standardisation of interfaces (plug &amp; play = Physical (congestion, voltage / current etc.) Application +) sensors for the needs of the infrastructure (hardware which monitors networks) and equipment</li> </ul>
WA3.3.3	Data selection	<p>The goal of this task is the analysing of existing data that can be used for CBM</p> <p>Setting by IT experts of railway undertakings, infrastructure manager and the component manufacturers</p> <ul style="list-style-type: none"> <li>• data format</li> <li>• frequency of data extraction</li> <li>• data transmission</li> <li>• data formatting like spike removal, clustering and classification (setting by IT experts)</li> </ul>

Task	Task Name	Task Description
WA3.3.4	Data analysis and pattern recognition	<p>The goal of this task is to analyse hidden patterns in huge sets of condition data</p> <p>Setting by data analysis team:</p> <ul style="list-style-type: none"> <li>• e.g. associative analysis, regression analysis etc.</li> <li>• e.g. supervised and un-supervised machine learning</li> <li>• case-by-case analysis of all fault predictions by vehicle engineering experts</li> <li>• detailed clarification of technical causes of the fault under operational conditions</li> </ul>
WA3.3.5	Conclusion for maintenance	<p>The goal of this task is to optimise maintenance procedures with respect to condition data</p> <p>Setting by vehicle engineering and maintenance experts of train operating companies and component manufacturers</p> <ul style="list-style-type: none"> <li>• interpretation with maintenance know-how of railway undertakings</li> <li>• recommendations for maintenance</li> </ul>
WA3.3.6	Integration into maintenance process	<p>To integrate CBM into the maintenance process under consideration of safety aspects</p> <ul style="list-style-type: none"> <li>• piloting modifications of maintenance plan of investigated vehicle</li> <li>• fixing the organisational structure (working and deciding teams)</li> <li>• setting up the safety plan</li> <li>• doing the investigations &amp; field data analysis</li> <li>• working out the modified maintenance plan</li> <li>• validation of the modified maintenance plan</li> <li>• supervising the introduced modified maintenance plan</li> <li>• verifying the modified maintenance plan</li> <li>• performing the safety confirmation</li> <li>• validation of the altered maintenance plan in operation and maintenance task planning</li> </ul>

Task	Task Name	Task Description
WA3.3.7	Information identification	<p>Identification of Information and Data directly and indirectly concerned by cross monitoring systems. This will include:</p> <ul style="list-style-type: none"> <li>• for Infrastructure: wayside monitoring systems <ul style="list-style-type: none"> <li>○ rolling stock components concerned: wheel sets, axles, bogies,...</li> </ul> </li> <li>• for rolling stock: CMS, driving control recorder,... Information related to driving behaviour (velocity, acceleration, braking, in-track signal transmission, ...)</li> <li>○ Infrastructure assets concerned: rail (especially in curves), signalling components (Speed control beacons – ERTMS, KVB,...), energy distribution,...</li> </ul>
WA3.3.8	Share monitoring data	<p>Active sharing of relevant monitoring data with IP1 and IP3:</p> <ul style="list-style-type: none"> <li>• development of an IT interface between IP1 and IP3 Data Warehouses</li> <li>• interfaces with IP1 and IP3 TDs, in order to give new opportunities for generating value based on data-centred approaches for design and maintenance</li> </ul>
WA3.3.9	Standardisation	<p>Define standards concerning in/outputs and related to:</p> <ul style="list-style-type: none"> <li>• physical interfaces (electric power, voltage, plug compatibility,...),</li> <li>• data flow and format,</li> <li>• physical data transmission infrastructure</li> <li>• on-board rolling stock software and databases</li> </ul>
WA3.3.10	Dissemination	Dissemination of innovative data analysis and modelling approaches, and collaboration with IP1 and IP3 data centric TDs





#### **6.5.3.4. Sub-work area 3.4 Smart Materials**

##### **Concept and objectives**

Smart materials are one of the most important researching directions in the development of high-tech new materials. Their properties can react to reversible changes in their environment by an external condition. Smart materials help in removing the boundaries between structural and functional materials, which may result in significant revolution in materials science development.

Modern mass transportation needs to be fast, efficient, comfortable and safe. Speed, energy efficiency and passenger comfort and safety have a lot to do with the design concept, smart components and the materials employed:

All these aspects can be optimised by using state-of-the-art composite materials and solutions resulting from a benchmark to be performed.

The largest effort in R&D in smart materials has been in the military aerospace sector, followed by the automotive and marine sectors. There appears to be very little application in the rail industry.

Comfort and safety have a lot to do with the design concept, smart components and the materials employed: the lighter train carriages are, the faster a train can accelerate, move and brake. A lighter train also uses less energy per passenger distance covered. Stronger, more durable and easy to clean materials translate into lower maintenance cost over the whole life span of a train.

Passenger comfort also requires lightweight, compact and durable materials, so designers can design train car interiors, or seat structures that offer passengers amongst other features the maximum individual space and leg room, a friendly and clean environment and excellent noise and pressure protection during high-speed motion. The key parameters of passenger safety are the fire, smoke and toxicity performance of the materials chosen. All these aspects can be optimised by using state-of-the-art composite materials and new emerging technologies as using a combination of functional, hybrid and multiple materials, sometimes coming from others transports (e.g. aerospace)

In railway industry, the use of smart materials has a threefold goal:

- Relief (energy savings, reduction in axle load, integration equipment and / or increased payload)
- Lower costs of acquisition, operation and recycling of rolling stock
- Acquisition of new skills

The main objective of this work is to explore the latest research in designing of smart materials and possibilities of applying various techniques and innovations in material science for railways. It will provide a report addressing the topics, issues, best practices and trends necessary to make the right decisions to guide rail business strategies, and future science and technology direction.

This benchmarking study will provide a way to compare smart materials in other transportation sectors and adapt the best processes and innovative materials to the rail sector.



### Linkage and alignments with Master Plan

Table 65 shows the links between WA3.4 and the objectives of the Shift2Rail Master Plan.

**Table 65: WA3.4 links to Master Plan objectives**

Master Plan objectives		Addressed by:
Improved services and customer quality	MP1 Improved reliability	<ul style="list-style-type: none"> <li>The aim is lowering maintenance costs by using the new opportunities of knowledge on vehicle's conditions by digitalisation. This will have strong impact on reliability, availability and LCC and thus on attractiveness and competitiveness of rail traffic.</li> <li>Advanced, quick, cost-effective and flexible design, manufacturing, construction.</li> <li>Increase the reliability and reduce the maintenance costs</li> <li>Improve capacity</li> <li>Improve passenger comfort</li> <li>Aim to help on developing interchangeable spare parts and future interoperability</li> </ul>
	MP2 Enhancing capacity	
	MP3 Customer experience	
Reduced system costs	MP4 Lower investments costs	
	MP5 Reduced operating costs	
	MP6 Externalities	
Enhanced interoperability	MP7 Respect and adaptation of TSIs	
	MP8 Removal of open-points	
Simplified business processes	MP9 Improved standardisation	
	MP10 Simplified authorisation	

### Relevant EU projects, national projects and past experience

Only few former EU projects have been carried out in this area and an example for application to noise and vibration control is InMAR (6<sup>th</sup> Framework Programme):

InMAR (Intelligent Materials for Active Noise Reduction)

The objective of the InMAR project was the research and realisation of intelligent, high-performance, adaptive material systems with integrated electronics for different individual applications. These are applicable for noise mitigation purposes – even in highly loaded structures as construction material – in the same manner that common passive or lightweight materials have been used up to now. Aside from the development of the materials or material systems themselves, this research also included their characterisation, simulation tools for the design process, handling and manufacturing techniques as well as the reliability of these material systems.





### **Implementation of the work programme**

WA3.4 is mainly dedicated to open calls.

The work plan for WA3.4 is presented here after in Table 66 and the Gantt chart, in Figure 121.



**Table 66: WA3.4 task details**

Task	Task Name	Task Description
WA3.3.1	Planning and research	<p>Put the resources together to implement the project e.g., develop surveys, seek cooperation from other companies, and find databases. already available.</p> <ul style="list-style-type: none"> <li>• Understand industry needs and business opportunities</li> <li>• benchmarks of smart materials and composite components used in other industries (aerospace...)</li> <li>• identification of smart materials and their dedicated applications in aerospace</li> <li>• identification of smart materials and their dedicated applications in automobile industry</li> </ul>
WA3.3.2	Analysis	<p>Comparison, selection to examine and create the findings adapted to rail.</p> <ul style="list-style-type: none"> <li>• identification of new materials and their possible application in rail industry</li> <li>• Exploring market opportunities alongside the innovated materials</li> </ul>
WA3.3.3	Recommendations	<p>After analysing the data and areas where Rail sector can improve, recommendations are developed.</p> <ul style="list-style-type: none"> <li>• Proposition of adapted use of new smart materials in the field of rolling stock conception and infrastructure design.</li> <li>• Some conclusions should be driven and summarised in a short report.</li> </ul>
WA3.3.4	Implementation	<p>After reviewing recommendations, rail sector can explore and implement those that are feasible.</p> <p>Rail industry are invited to guide their innovations thanks to the study conclusions and try to test and use some adapted new materials</p>



Figure 121: WA3.4 Gantt chart

WA3.4- Smart Materials		2016				2017				2018				2019				2020				2021 - 2024			
Task	Description	Q1	Q2	Q3	Q4	Q1	Q2	Q3	Q4	Q1	Q2	Q3	Q4	Q1	Q2	Q3	Q4	Q1	Q2	Q3	Q4	Q1	Q2	Q3	Q4
WA3.4.1	Planning and research					■	■																		
WA3.4.2	Analysis													■	■	■	■								
WA3.4.3	Recommendations													■	■	■	■								
WA3.4.4	Implementation																	■	■	■	■	■	■	■	■



### **6.5.3.5. Sub-work area 3.5 Virtual Certification**

#### **Concept and objectives**

Today, the authorisation process for putting into service new rolling stocks or sub-systems is largely based on full-scale field and line tests, which is not only expensive, but also time and capacity consuming. For example, the line assessment of the dynamic behaviour of a train can last several months and costs about a million euros. Furthermore, the whole process may be repeated for several countries and the same costs and test duration duplicated, which is hardly compatible with an opening up of the market to competition aiming at a more competitive offer in Europe. There is hence a clear need for a reduction of the duration and cost of the process for an appropriate authorisation to put into service.

Another issue is sometimes encountered when performing validation tests. As an example, the train dynamics line tests as defined in European standard EN14363 require some tests conditions that are difficult to meet (e.g. ranges or statistical distributions according to track curvatures, cant deficiencies, etc.). Those tests on specific dedicated routes impact the train path capacity, commercial traffic and lead to additional costs for the stakeholder. Additionally, even if all the mandatory conditions are fulfilled, line tests do not capture all the possible operating conditions. For all these reasons, there is a need to simplify the procedures and to improve the representativeness of the test conditions.

Technically, the way to make a breakthrough in performance is to introduce progressively numerical simulation in a mixed virtual/experimental authorisation, resulting in less field tests.

Some recent work, led within European projects, has helped to progress in this area but simulation is not yet used for validation because of the many remaining technical “open points”, but also of many non-technical reasons (organisations, cultural habits, availability of necessary data, multiplicity of stakeholders in the process and fragmentation of responsibilities, etc.). Nevertheless, the switch to virtual certification seems ineluctable and can be seen as a great opportunity for the sector. As a reminder, even in the nuclear and aeronautical fields, very sensitive to safety, simulation is widely used for design and validation to complement full-scale tests which, for obvious reasons, remain limited. In the automotive industry, through the intensive use of virtualisation, the design and validation cycles have been drastically accelerated during the past decades.

A European research programme reveals to be the most adequate framework to perform collaborative work, gathering complementary expertise from industrials, operators, infrastructure managers and academia. It will facilitate the convergence towards shared processes and maximise the chance of their translation into standards.

Virtual certification raises many technical issues, needing the contribution of engineers who are specialised in specific technical domains (for instance in the case of rolling stock: braking, traction, TCMS, running gears...). For that reason, the technical developments are carried out within the associated IPs and TDs. However, there is still a need of:

- Appropriate coordination among IPS and relevant TDs to share generic approaches and methods when possible



- Common interface with standardisation bodies (ERA, CEN, CENELEC...)

WA3.5 aims at creating a very lean structure to handle these two roles.

WA3.5 will be responsible for

- the organisation of meetings (at least one per year) gathering the leaders of the technical tasks related to virtual certification, task participants, IPs leaders and other railway experts
- an overview of the state-of-the-art, the gap analysis and the barriers identification for the virtual certification in the different domains (traction, TCMS, running gear, braking system)
- an overview of the generic methods that are developed, the procedures that are defined and the solutions found to overcome the barriers during the Shift2Rail initiative
- an overview of the TDs work progress
- defining a dissemination plan targeting the relevant standardisation bodies

The goal is to maximise the chance to reach applicable spare methods, but above all, comprehensive practical industrial processes for validation of rolling stock sub-systems and systems based on a mixed experimental/virtual approach, by finding synergies between TDs and coordinating the dissemination activities. The task will aim at steering the projects outcomes in the standards and guidelines.

In the TDs description of work, proofs of concept for mixed testing/virtual certification are planned. The role here is to check that the demonstrators will be effectively rolled out and to anticipate any risk of failure.

### **Impact**

The authorisation process for putting new rolling stock into service is largely based on full-scale field and line tests, which **is long, expensive and capacity consuming**.

Moreover, it can only be performed at the end of the design process, which does not help to reduce the **time-to-market**.

The mixed experimental/virtual certification process proposed by WA3.5 brings as a solution:

- A new methodology and tools to implement more virtual validation and assessment of the components, sub-systems and systems.
- Transfer of tests from on-track train testing to bench testing and simulations.

Concerning the complicated and non-harmonised (European level) assessment standards and the inconsistencies and/or interpretation divergences these might represent, WA3.5 brings the impact of clearly defining a new **overall industrial virtual certification process** and to unfold it on real cases, **demonstrators** of the approach (up to TRL7).



The most significant quantitative benefits to be obtained in relation to the objectives listed in the previous sections are:

- Life Cycle Costs – reduction in capital costs (rolling stock): reduction of the traction system, TCMS, train dynamics and braking system validation and authorisation costs by around 30% through simplification, harmonisation of rules and shifting from "on site" tests to simulation and/or bench tests
- Time-to-market: reduction in the duration of the authorisation process to put into service around 30% (even more for cross-acceptance) through simplification, harmonisation of rules and shifting from "on site" tests to simulation and/or bench tests
- European standards will be updated accordingly.

WA3.5 will support the competitiveness of the EU industry by:

- harmonising and simplify Traction/braking/TCMS/train dynamics assessment processes to decrease cost and duration via introduction of virtual tools
- bringing proof tangible benefits for the end user through LCC reduction

The degree of maturity of the envisaged solutions will depend on the domain, but the final results could reach TRL5 or 7. Also, following the results from WA3.5 recommendations for the revision of relevant standards could be provided.



### Linkage and alignments with Master Plan

Table 67 shows the links between WA3.5 and the objectives of the Shift2Rail Master Plan.

**Table 67: WA3.5 links to Master Plan objectives**

Master Plan objectives		Addressed by:
Reduced system costs	MP4 Lower investments costs	Reduction of Life-cycle-costs through reduction of authorisation costs <ul style="list-style-type: none"> <li>Proposal for mixed experimental/numerical processes, resulting in less on-site testing, more lab or vehicle testing and more simulations.</li> </ul>
	MP5 Reduced operating costs	
	MP6 Externalities	
Enhanced interoperability	MP7 Respect and adaptation of TSIs	Facilitating cross-acceptance procedure <ul style="list-style-type: none"> <li>Common assessment procedures including standardised lab tests, vehicle tests, on-track tests and simulations procedures.</li> <li>Easier cross-acceptance process, by introduction of virtual testing.</li> </ul>
	MP8 Removal of open-points	
Simplified business processes	MP9 Improved standardisation	Reduction of Time and Cost of (sub)-Systems authorisation Process. <ul style="list-style-type: none"> <li>Improved standardisation and authorisation</li> <li>Development of harmonised rules for assessment based on mixed experimental and numerical approaches</li> </ul>
	MP10 Simplified authorisation	

### Relevant EU projects, national projects and past experience

Several past EU R&D projects have helped pushing virtual tools and methods into the authorisation process. Industry, operators, infrastructure managers, suppliers, research laboratories, standardisation organisation and many others have been involved in past successful projects. The list of E.C. R&D projects related to virtual certification is as follows:

- PANTOTRAIN (2009-2012): Virtual certification methods of dynamic performance of pantograph/catenary system
- DYNOTRAIN (2009-2013): Virtual certification methods of dynamic performance of railway vehicles



- AEROTRAIN (2009-2012): Virtual certification methods of evaluation of the crosswind and aerodynamic effects of a train on the environment
- ACOUTRAIN (2011-2014): Virtual certification methods of acoustic performance of railway vehicles
- EUREMCO: Harmonisation and simplification of the authorisation process of rail vehicles against Electromagnetic Compatibility (EMC)

### **Implementation of the work programme**

Work on WA3.5 is organised around three phases/tasks

The involved partners will collaborate in two fields:

- Technical collaboration between the “virtual certification tasks” leaders of TD1.1, TD1.2, TD1.4, TD1.5, the participants to this task and advisory experts (to be identified)
- Dissemination with ERA, CEN, CENELEC, in connection with the sub work area 3.2 Standardisation.

WA3.5 aims at coordinating all the “virtual certification tasks” that are defined in IP1 TDs. The interactions with the associated TDs are therefore strong. The related TDs and tasks are:

- IP1 – TD1.1. “Traction”: Task 1.1.5 – Requirements, specifications & developments for virtual validation and authorisation (up to TRL 4/5)
- IP1 – TD1.2. “TCMS”: Task 1.2.4 – Virtual Placing on the Market
- IP1 – TD1.4. “Running Gear”: Task 1.4.7 – Virtual certification of train dynamics
- IP1 – TD1.5. “Braking system”: Task 1.5.6 – Authorisation process

The work plan for WA3.5 is presented here after in Table 68 and the Gantt chart, in Figure 122.



**Table 68: WA3.5 task details**

Task	Task Name	Task Description
WA3.5.1	State of the art, gap analysis and barriers identification	In the TDs, state of the art and gap analyses are planned in the activities. Some generic conclusions should be driven and summarised in a short report.
WA3.5.2	Overview of the generic methods and process	<p>Annual meetings will be organised in order to share:</p> <ul style="list-style-type: none"> <li>• benchmarks of methods and procedures used in other industries</li> <li>• methodologies for numerical models validations, statistical approaches for reliability assessments, mixed experimental/numerical approaches, Hardware-In-the-Loop (HIL) techniques, validation criteria, standardisation of software framework...</li> <li>• solutions found to overcome the non-technical barriers</li> <li>• procedures definition, consistent with a V-model used for the pre-design, design and validation of sub-systems and systems</li> <li>• TDs work progress</li> </ul> <p>The participants to the meeting should be: the “virtual certification” tasks leaders, the IP1 leader, the task participants, and some advisory experts to be defined (IP3 experts, RSSB, etc.)</p>
WA3.5.3	Dissemination – Liaison with the standardisation bodies	<p>The work will consist in identifying the relevant CEN/WGs and their conveners, determining when official communication should be organised by synchronisation between the projects timelines and the ERA, CEN and CENELEC timelines.</p> <p>The task technical leader will carry out the coordination of the ‘virtual certification’ tasks disseminated in TDs of IP1. With the contribution of the tasks leaders, it will prepare meetings, reports, annual plans and will attend IP1 Steering Committee meetings when requested to. Attendance to other Shift2Rail committees and dissemination events are expected too.</p> <p>Open Calls: No Open Calls are identified</p> <p>The participation of the European Railway Agency in this activity as advisory body is requested, in order to guarantee that the outcomes are applicable and could be regulated.</p> <p>Railway experts and IP3 experts could bring additional support.</p>

Figure 122: WA3.5 Gantt chart

WA3.5- Virtual Certification		2016				2017				2018				2019				2020				2021 - 2024			
Task	Description	Q1	Q2	Q3	Q4	Q1	Q2	Q3	Q4	Q1	Q2	Q3	Q4	Q1	Q2	Q3	Q4	Q1	Q2	Q3	Q4	Q1	Q2	Q3	Q4
WA3.5.1	State of the art, gap analysis and barriers identification																								
WA3.5.2	Overview of the generic methods and process																								
WA3.5.3	Dissemination – Liaison with the standard. bodies																								

The estimated total budget for WA 3 is around 3.5 M€.



#### 6.5.4. Work Area 4 –Smart Mobility

The overall objective of WA4 “Smart Mobility” is to improve railway planning and operation by means of precise railway simulation (WA4.1) and by specification and implementations of message exchange between Freight Operations and Traffic management systems (WA4.2).

The end results of WA4 “Smart Mobility” are leading to improved reliability and customer experience, which in turn will lead to reduce system costs and simplify business processes.

Various activities within Shift2Rail focus on linking data and improving operations. The objective of the cross-cutting activities is to maximise the global efficiency at the system level. These CCAs leverage selected components from all IPs. One smart way to improve the railway system is to establish and use common standards and architectures for data exploitation based on a real-time seamless access, enabling railway stakeholders to optimise their operations and planning.

The approach chosen in CCA Working Area 4 is twofold, represented in the two sub Working areas WA4.1 Smart Planning and WA4.2 Integrated Mobility Management (I2M).

Figure below illustrates the two tasks of WA4 along the process of railway planning and operations.

**Figure 123: Railway planning and operation phases and tasks within Working Area 4**

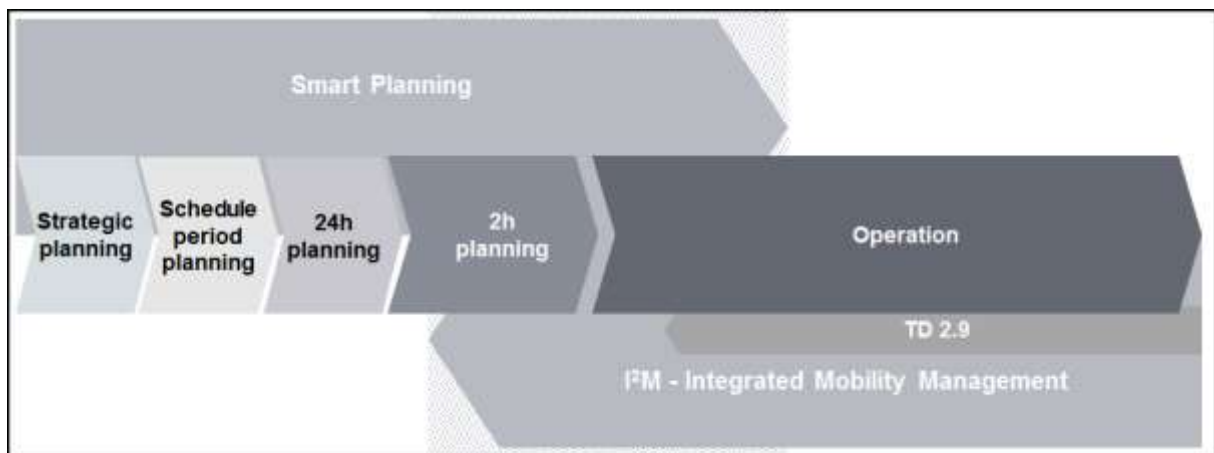

WA4.1 aims at improving planning activities of various stakeholders in the railway system by means of precise railway simulation. Its concept will cover the early phases of railway planning and optionally include an outlook on operation.

A group with a strong focus on railway operations supported by specialised IT knowledge will collaborate jointly on this task. The work in In2Rail, TD2.9 and I2M can be the general framework on which Smart Planning can be built on in a later stage.

WA4.2 is aiming at specification and implementation of sub-structures needed for automated message exchanges between freight operations and traffic management system via the integration layer. Tools will be specified and developed to extract data from a data silo, process them and forward them to the different business services. Specific business applications to support the increase of performance of freight operations will be specified and developed.



A group of manufacturers and IT service providers will collaborate jointly on this task and the results will be reflected against operational experience from an Infrastructure Manager.

Some partners will take part in both tasks and will support knowledge transfer between the tasks. Furthermore periodical meetings will take place to ensure the exchange of work progress, results, to deliver input and to benefit from each other.

A close link exists between WA4 and various other WAs and TDs within the Shift2Rail programme. Examples are:

- Data from train control and monitoring system (IP1, TD1.2)
- Data from freight access and operations (IP5, TD5.2)
- Architecture, integration layer and data management system from traffic management system (IP2, TD2.9)
- Data about system's conditions (nowcast, forecast) and maintenance activities (IP3, TD3.6)
- Technical framework developed for railway services (IP4, TD4.1)

A close collaboration between these activities and WA4 will be set up in order to exploit the technological progress in these projects, to deliver input for these projects and to benefit from their experience.

#### **6.5.4.1. Sub-work area 4.1 Smart Planning**

##### **Concept and objectives**

The task Smart Planning will provide the basis for an open micro-level simulation, integrating planning activities and status information from the various actors within the railway system, e.g. RU with their fleet and staff planning processes, IM whose assets are in a certain condition, schedule planning and external parameters.

Current and future IT capabilities and open data formats and interfaces will allow to extend the scope of micro-level simulation to encompass large networks, while also including more factors relating to the overall system, significantly increasing the level of detail. This will allow estimating the impact of local occurrences (e.g. local construction work, disruptions, etc.) on the entire network with more precision than present.

The aim of Smart Planning is to enable railway stakeholders to make the best decisions for the overall system, for example concerning schedules and the availability of rolling stock and staff, based on up-to-date operational data, taking into account all essential information in order to ensure quality promised is delivered to customers. The task also enables optimum allocation of funds by using knowledge of all relevant system parameters and their interaction to promote the best possible use of existing capacities. With limited resources this data will provide a basis for operating the railway system far more cost-efficient in the long term.



Combining IM and RU planning, the task integrates interaction of different sub-systems of the railway system. It complements the technical work in S2R by adding an integrated perspective on planning activities and is essential to establish smart business processes in the future. It will optimise operation and planning and ultimately services to the end users. A European approach is envisaged to develop WA4.1 to deal with complexity, mutual dependencies and the need for interoperability of the European railway system.

The potential for system improvement is immense. In a recent example case, a detailed operational analysis at a major railway junction in northern Germany focused on operational and planning improvements led to a reduction of approximately 20% in delays (e.g. local dispatching rules, rolling stock turnaround cycles, driving behaviour). In the long term Smart Planning will have significant impact on interoperability, reliability and develop towards a predictive planning system.

The task addresses railway operational planning, which is crucial for a cost-efficient, reliable and robust railway system all across Europe. The comprehensive approach includes all key aspects of the railway system identified in previous research and operational analysis and substantially enhances its value in both the long and short term.

The strategic focus of the task is on the following causes of delays: planning, operations and secondary sources. These issues are vital for increasing punctuality and developing a more robust railway system.

Precise railway network simulation will enable RU and IM to identify operational bottlenecks and harmonise long-, middle-, and short-term planning activities. It will support all actors to generate recommendations for decisions that enhance efficient and punctual operation. Furthermore, it can provide support for strategic investment decisions and serve as a tool to determine the effectiveness of measures, thus allowing for the optimum allocation of resources and enhancing the sustainability of the railway system.

The approach for this project will ensure scalability for the task, thereby adding value to the entire European Railway Community.

State-of-the-art analyses and operational forecasts are either based on macro-level models, which focus on capacity effects and display low precision with regard to the real system, or micro-level models, which describe the system precise (e.g. including local signal or switch positions), but which are currently limited to small scale applications and are predominately used for infrastructure planning and assessing timetable robustness.

**Figure 124: Punctuality is the result of the interaction of various parameters**

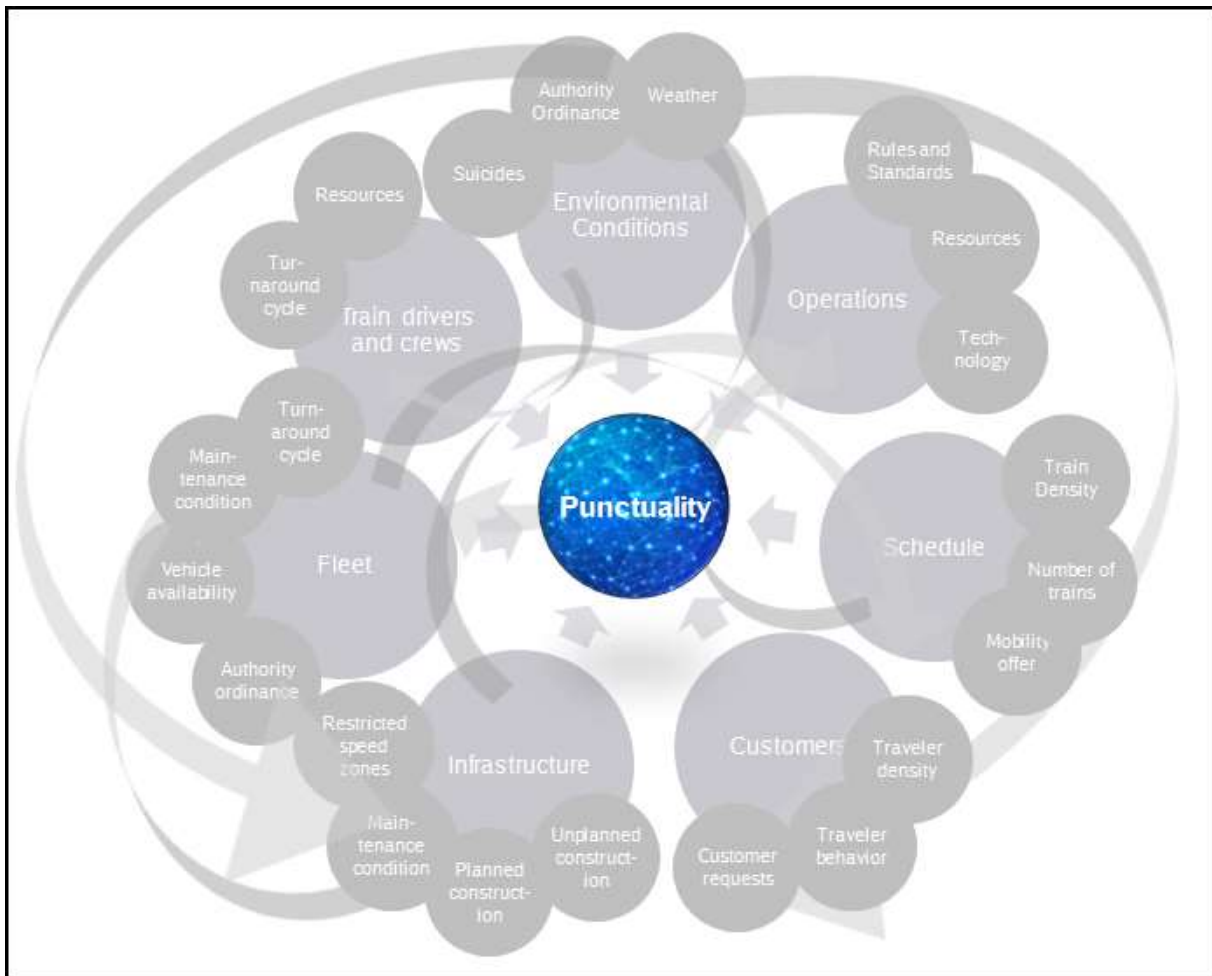

### **Impact**

The task will bring a significant technological advance in the field of precise railway network simulation and railway operational planning. The use of state-of-the-art IT and smart data analysis will allow to incorporate substantial detail to the simulation and to extend the scope from small areas to larger regions and later entire cross border networks without losing the precision in predictive capacity. Operational data and output of planning activities from all actors across the railway system can be included in this flexible and open analytical framework (Figure ?).

Smart Planning is a key instrument to resolve urgent operational issues in the network, but it will also help pave the way towards a more integrated approach to railway planning and operation that involves a magnitude of stakeholders in the system. The task addresses the challenge of service quality, the cost challenge and innovation all evoked in the Shift2Rail Master Plan.

A conservative estimate based on the current causes for delays in long-distance traffic shows that more than 40% of the overall delay time will be addressed (e.g. from planning, operations and secondary sources such as train connections). Moreover, current data shows that coordinated operational planning interlinking the different actors will increase the system's robustness in the event of disruptions and allow for quick revisions of operational planning, thereby enhancing

recovery times significantly. The task will assist railway operators in improving their decision-making and processes and so safeguard the railway system's sustainability and competitiveness. It promotes open data exchange and communication.

The integrated approach and the focus of the analysis for model validation will help establish a Single European Railway Area (SERA) and it can be augmented by means of a thorough operational analysis of parts of the TEN-T corridors and their cross-border connection points.

Establishing closer links between the different stakeholders in the railway system, data exchange and open data formats (e.g. XML) offer potential for further improvements to the system, smarter design of business processes and even new business opportunities (e.g. data exchange with service providers outside the system).

### **Linkage and alignments with Master Plan**

Table 69 shows the links between WA 4.1 and the objectives of the Shift2Rail Master Plan.

**Table 69: WA4.1 links to Master Plan objectives**

Master Plan objectives		Addressed by:
Improved services and customer quality	MP1 Improved reliability	<ul style="list-style-type: none"> <li>• Integrated approach to railway planning will increase punctuality</li> <li>• Stability of the system is increased and resource allocation is improved</li> <li>• Use of smart data and new IT capabilities to improve operational planning</li> </ul>
	MP2 Enhancing capacity	
	MP3 Customer experience	
Reduced system costs	MP4 Lower investments costs	
	MP5 Reduced operating costs	
Simplified business processes	MP9 Improved standardisation	
	MP10 Simplified authorisation	

### **Relevant EU projects, national projects and past experience**

The results from EU projects In2Rail and On-Time Project will be taken into account.

### **Implementation of the work programme**

Developing the project will start with a small-scale environment (e.g. major railway junction) and progress to larger parts of the network (corridor or region). With project progress, it will provide verification to be scaled up for larger networks and other operational environments. Development will start with long-term and strategic planning, constituting some fundamentals for later optional short-term planning and starting to ensure coherence between the different planning aspects. Continuous feasibility checks and proof of concepts are implicit. The basic model will be validated and compared against actual network operations based on data from IM and RU samples.

Optionally, a special focus of the analysis will be on an exemplary TEN-T network corridor (e.g. parts of the Rhine-Alps or Scandinavia-Mediterranean corridor). Dense traffic on these routes, mixed regional, long-distance and freight operations, plus the routes' significance for the European network



(with cross-border connections) make these corridors an ambitious choice for testing the concept and validating.

Open communication and data exchange also facilitated by the data silo provided by WA4.2 (I2M) is a prerequisite for integrated planning procedures. The task will serve as a proof of concept for these processes. In line with the current legal structure of the railway system with shared responsibility, a Member or any other third party can operate Smart Planning. Railway stakeholders willing to contribute with data will in reciprocity benefit from the results generated. The work done in In2Rail, TD2.9 and I2M can provide the general framework on which Smart Planning can be built on. TMS databases, integration layer and functions like the traffic optimiser and other decision support systems developed in TD2.9 will be taken into account or used for further improvement of the simulation.

WA4.1 is split in various project steps. Several partners with different competence profiles are needed to carry out the work.

Members are expected to contribute their broad experience in railway operation and integrated railway operation. This covers issues such as railway traffic planning, railway traffic simulation and operational data for model validation. Members will analyse the different factors influencing the planning and the operation of the railway system. Results of the project will be compared with existing experience of the Members. Furthermore, they will contribute to the analysis of disturbance and model validation and ensure knowledge transfer from TD2.9 and TD5.2 and from own company projects and EU projects (e.g. On-Time Project, In2Rail).

Members or Open Calls are expected to contribute to model development, model validation and simulation. They will ensure knowledge transfer from TD2.9 and various freight related research projects. They will provide a software tool which is in use in major European networks to facilitate an easy and budget efficient pilot development. IT experts will support both directly from 'inside' the In2Rail project and consultation from other experts. They will help to ensure a smooth handover of the In2Rail outputs for proper development and exploitation inside Shift2Rail.

Members or open calls are expected to start to develop dispatching rules for punctuality: Development of dispatching algorithms for simulation in order to improve overall punctuality in the system. This activity will be initiated, monitored and controlled by the technical coordination team in order to ensure on-time and form-fit delivery for successful integration into the activities. Furthermore, a comparison of simulation software tool for the simulation work in WA4.1 will be performed linked to the results of On-Time Project. Deterministic algorithms will be developed to describe the mutual influence of the parameters used in the simulation in order to develop rules to be implemented in the simulation.

Further potential open calls can cover optimisation of model results, the development of methodology and proof of concepts based on basic model with small environment (part 1), further optimisation of model results-based on strategic model from task WA4.1.3 (see below) and concept developed in part 1 (part 2)

The main part of the project is innovative. Basic research is covered mainly in open calls, e.g. the development of dispatching algorithms for micro-level railway simulation.





Areas for open calls are included in the task description. The required competencies include IT experts, micro-level railway simulation, the development of dispatching algorithms and potentially also the development of optimisation algorithms for large amounts of data resulting from the simulation.

The work plan for WA4.1 is presented here after in Table 70 and the Gantt chart, in Figure 125.

**Table 70: W4.1 task details**

Task	Task Name	Task Description
WA4.1.1	Project design and integration	Manage the overall project and to ensure technical coordination with various relevant activities in S2R and the stakeholders.
WA4.1.2	Railway planning activities and basic model development	<p>Lay the fundamentals for an enhanced integrated micro-level railway simulation system including first development steps concerning impact of disturbances on railway operation. Continuous model validation steps are implicit.</p> <p><u>WA4.1.2.1 Analyse planning activities of stakeholder.</u> To identify all relevant parameters that need to be taken into account in simulation and to collect information on existing analyses on interdependencies in the railway system. Furthermore, an analysis of the planning processes of the different railway stakeholders (RU, IM) is done in order to identify interfaces to the simulation model.</p> <p><u>WA4.1.2.2 Basic model development.</u> To build a simulation network under consideration of results of various existing simulations and their results, e.g. in major railway hubs.</p> <p><u>WA4.1.2.3 Establish technical condition.</u> To provide hardware and software for the entire project time.</p> <p><u>WA4.1.2.4 Impact of disturbances.</u> To identify and prioritise disturbances. The main disturbances are identified and considered in the model in a stochastic way based on past operational data.</p> <p><u>WA4.1.2.5 Prognosis test based on micro-level simulation.</u> To perform a punctuality prognosis based on the existing model parameters and to perform a comparison with the results from existing tools. This includes interpretation of the results and lessons learned for further project progress.</p> <p><u>WA4.1.2.6 Case study corridor.</u> To refine the model for a specific corridor and the validation of the results based on operational data.</p> <p><u>WA4.1.2.7 IT: Fundamentals, requirements, interfaces.</u> To define the fundamentals in terms of data formats, architecture, interfaces, requirements and software. This includes a comparison of potential software tools coming from open call.</p> <p><u>WA4.1.2.8 Simulation technology and automation.</u> Further development of the simulation technology in order to automatise the work flow for future simulations.</p>
WA4.1.3	Model refinement and strategic planning	<p>Qualify the simulation model for strategic planning purposes and to increase model precision.</p> <p><u>WA4.1.3.1 Further development of simulation tool.</u> To continue the work in 2.8 for a further development of the simulation technology in order to automatise the work flow for future simulations.</p> <p><u>WA4.1.3.2 Expand simulation to larger parts of the network.</u> To extend the regional scope of simulation from the corridor and hubs analysed in WA4.1.2.6 to a larger region including model validation.</p>





#### **6.5.4.2. Sub-work area 4.2 Integrated Mobility Management (I2M)**

##### **Concept and objectives**

Integrated mobility management must be smart and based on a real-time seamless access (without duplication) to heterogeneous railway data sources (signalling data, maintenance plans, environmental conditions, fleet status, passengers requests and needs; etc.) with a view to enabling all rail stakeholders to measure their performance and optimise their operations and planning, and ultimately the service they offer to the end users (meaning travellers and freight customers). It will also provide a seamless exchange of information between fixed and mobile services in different transport modes, and achieve a standardisation of Interfaces, processes and data structures on such a level to ensure compatibility independent from supplier's subsystems and modules.

I2M will provide this step change towards seamless fully-automated process integration of railway related services and other modes of transport. This Integrated Process will support intelligent, automated and flexible rail traffic operations, but also an integrated approach to the optimisation of railway architecture and operational systems at network, route and individual train level. These will reconcile business and operational requirements (namely customer service, capacity, speed, timekeeping, energy, asset management) with real-time field and asset condition monitoring and intelligent traffic planning.

For freight and passenger operations it is essential to receive high precision and real-time forecast of traffic status and demand to manage resources such as availability of platforms and terminals, locomotives or coaches, operators, drivers and forecast and others in an efficient way. Maintenance services depend strongly on the dynamic planning of free slots to execute the maintenance activities and updated now-casted and forecasted periods of availability of the assets for maintenance are key.

The overall objective of WA4.2 is to specify, develop and integrate all necessary elements into the traffic management system specified under IN2RAIL and TD2.9 to integrate actual and forecasted traffic asset and freight operations status information into a seamless operation process.

The works under WA4.2 brackets activities and developments of different work programmes of Horizon 2020 and Shift2Rail and are aiming to specify and develop the functionalities finally needed to deliver in a first step an integrated and automated real-time rail operations process applying now-and-for-casted data for traffic, asset and freight operations status.

Starting with Horizon 2020-In2Rail-Subproject I2M then followed from Shift2Rail TD2.9 Traffic Management System (TMS) and concluded from CCA WA4.2, the design of an advanced real time rail operation management system will demonstrate in a first release the integration of traffic control, asset status information and specific freight related data in the traffic management process.

IN2Rail will cover the generic requirements development (In2Rail WP8 Task1) and proof of concept (IN2Rail WP7 Task3) for a new standardised communication structure (integration layer) which links rail operations services such as TMS, asset management, energy management, freight operations, passenger information, fleet and crew management, external services and others.

The Lighthouse project contains further the generic specification work and proof of concept for a standardised framework for rail business services IN2RAIL Task 8.2) such as a TMS allowing a "plug



and play” installation of dynamic service applications and the specification of a standardised operators workstation (IN2Rail Task 7.2).

Within In2Rail WP9 the generic requirements for an “asset status now” and forecasting functionality is specified and will be demonstrated with a proof of concept. These activities will then be continued and finalised under Shift2Rail IP3 TD6.

Under Shift2Rail the final structures for TMS and asset status information to be exchanged via the integration layer will be developed and prototypes up to TRL4, and will demonstrate the results of automated data exchange. Business service application SW will be developed within TD2.9 for TMS applications, within TD3.6 for Asset Status Now- and Fore-Casting Algorithms and within TD5.2 for Freight Applications. The finalisation of the design of a WEB-IF will allow Passenger Information Systems and Services, which are external to Rail Operations (e. g. links to local public Transport systems), to benefit from the new integrated and automated operational approach.

Within the CCA-WA4.2 activities the specific data structures needed for the targeted high performance freight applications will be implemented into the integration layer and the proposed demonstrator will present the integrated automated and real time system processes supporting TMS, Freight and Asset Management Operations. To achieve this goal, CCA-WA4.2 also contains activities to develop specific modules able to extract data from a “Data Silo” or business server for specific data located these Data Storage Units are mandatory for the targeted integrated processes between TMS, Asset Management and Freight Operations.

As final outcome/added value the activities performed under CCA WA4.2 will lead to a framework for rail operations that integrates status information of interconnected services into their processes, allowing the exchange of information between internal and external clients via an integrated communication structure. New rules and business logic for freight supported from reliable dynamic traffic status information from the traffic management system will lift freight operations to a new level of effectiveness and performance.

Passengers and Infrastructure Managers will benefit from an improved availability and reliability of Rail Infrastructure and higher punctuality of the traffic based on integration of now-casted and forecasted asset status (IP3 TD3.6) into the traffic management process (IP2 TD2.9). This will also improve the offering of external services such as multimodal urban transportation systems required by passengers to complete their trip, or corridor management for cross-border freight operations.

The integration and exchange of information between traffic and asset management processes will significantly improve the quality and performance of all maintenance operations. This will lead to a much better planning of resources (staff, materials, equipment, and slots for maintenance activities) and will increase the reliability of assets resulting in higher capacity and a reduction of cost.

### **Innovation**

The main innovative achievement of the programme described will be that for the first time actual and forecasted status information of traffic, asset and freight operation will be seamless integrated into the operation process. Standardised, integrated and automated processes for data management and exchange will provide a significant improvement in efficiency and performance.



Specific focus within WA4.2 will be the basic research of adapted and advanced principles for freight traffic operations based on the benefits provided by the integration of systems/processes developed under IN2RAIL, Shift2Rail IP2, IP3, and IP5 within the specified works of WA4.2.

Future activities not addressed under this work programme will continue to integrate other services such as fleet and crew status and energy infrastructure. To achieve these goal similar related activities as scheduled under this programme can be envisaged.

### **Impact**

WA4.2 will deliver a capacity and reliability increase caused through the integration of high advanced now- and forecasted asset status information in the dispatching process. Based on this integration reduced delays of at least 10% can be expected.

Cost improvements can be expected from the integration of the different new functional applications and modes that will lead at least a 10% cumulated savings in:

- Operational cost of rail traffic, including energy, wear of vehicles, delays, increased productivity and others,
- Increased productivity through better locomotives utilisation, reduction of wait times at freight or station terminals,
- Operational cost of staff in control centres,
- Life-cycle cost reduction of Railway Infrastructure Assets.

Complemented by a cost reduction of at least 10% for investments in;

- Hardware on the level of an Control or Management Centre,
- Functional service application (SW),
- Adaptations of non-compatible subsystems from different suppliers.

### Linkage and alignments with Master Plan

Table 71 shows the links between WA 4.2 and the objectives of the Shift2Rail Master Plan.

**Table 71: WA4.2 links to Master Plan objectives**

Master Plan objectives		Addressed by:
Improved services and customer quality	MP1 Improved reliability	<ul style="list-style-type: none"> <li>Integration of different Business services related to Rail operations into one real time Management system</li> <li>Optimisation of available resources</li> <li>New functionalities addressing optimisation of freight operations</li> </ul>
	MP2 Enhancing capacity	
	MP3 Customer experience	
Reduced system costs	MP4 Lower investments costs	
	MP5 Reduced operating costs	
Simplified business processes	MP9 Improved standardisation	
	MP10 Simplified authorisation	

### Implementation of the work programme

WA4.2 has links with IN2RAIL, WP6, 7, 8 and 9, Shift2Rail IP2 TD7, 9 and 11, IP3 TD6 and IP5 TD2. The Partners involved in CCA WA4.2 will bring the know-how developed under IN2RAIL, the linked TDs under Shift2Rail and the necessary operational background from the field to secure the success of the proposed activities.

The works under WA4.2 will focus on:

- Upgrading the Data structure of integration layer to meet freight operation requirements.
- Specifying and developing Tools (Plug-Ins) to link in the first step TMS, Freight,- and Asset Management operations to enable the automated Data exchange and the seamless integration of those data in service applications. Asset Management (IP3 TD3.6 IP3 TD3.9) Freight Operations systems (IP5 TD5.1, TD5.2 and TD5.5) and the Traffic Management system (IP2 TD2.9).
- Specifying and developing advanced business application modules to enable the TMS to the increase of performance of Rail Freight Operations as Freight operations have very specific requirements for the traffic management system to allow efficient operations particularly approaching bottlenecks and inside specific business areas in terms of available track, lifters & cranes, platforms etc. and in parallel allowing a higher level of flexibility of train routes used or timetables applied as compared to passenger transportation.
- Support a better management of freight operations with improved estimated time of arrival (ETA) calculation, and slot planning/management (cross-border, cross-network), and real-time freight monitoring/ customer information via tracking & tracing.

The work plan for WA4.2 is presented here after in Table 72 and the Gantt chart, in Figure 126.

**Table 72: W4.2 task details**

Task	Task Name	Task Description
WA4.2.1	Technical assessment and integration	System engineering activities addressing system or subsystems standardisation and/or technical alignment and coordination for the work programme specified under CCA WA4.2.
WA4.2.2	Upgrade of integration layer	<p>To specify and implement the data structure and necessary subroutines into the specific sub-layer foreseen for the data exchange between TMS and Freight Management systems. The works will be carried out on the based on the specifications developed under IN2RAIL and Shift2Rail TD2.9</p> <p>This task will result in an upgrade of the specification and architecture of the integration layer (IP2 TD9, Horizon 2020) and a system prototype demonstrating the successful implementation.</p> <p>All specification work will be done collaboratively between the partners participating in this task.</p> <p>Complementing system/sub-system prototypes TRL3/4 including IF and the enhanced message structure allowing demonstrating a successful implementation will be developed</p> <p>As a second step a prototypes will be developed and tested.</p> <p>The detailed definition and structure of prototypes will be defined at a later stage</p>



Task	Task Name	Task Description
WA4.2.3	TMS application supporting high efficient Freight Operations	<p>Specification and development of set of complimentary business applications supporting the increase of performance of freight traffic being part of the TMS Process. Within the generic definition of the overall system architecture (IN2RAIL) a final definition whether this service will be implemented into the TMS and/or/partially as business application tool connected to a future data silo will be set.</p> <p>The application as such will focus on freight related functionalities /subroutines addressing including and enabling efficient cost models to be applied, resources management e.g. staff, locos, terminals to be aligned and integrated in the operational traffic management/dispatching process</p> <p>A set of functional complementary SW module prototypes TRL3/4 including interfaces will be developed and tested.</p> <ul style="list-style-type: none"> <li>• Freight functionalities and resource mapping for the management of dangerous goods,</li> <li>• Integrated automated dispatching functions for freight incl. industrial heavy haul operations into traffic management / traffic control process. Based on available budget this prototype may additionally include the integration of an existing legacy system with integrated traffic control and asset information management to proof the integration of legacy systems,</li> <li>• Conflict detection &amp; resolution for freight application, comprising: <ul style="list-style-type: none"> <li>○ Collection and integration of freight related information into forecast algorithm</li> <li>○ Integration of deadlock prevention due to limited crossing facilities in freight networks</li> <li>○ Development of single track optimisation pattern</li> </ul> </li> <li>• Prototype applying driver advisory principles showing how to optimise the operating envelope.</li> </ul> <p>This task will further include activities to designing concepts for annual and ad-hoc timetable planning with operations, best practice and state-of-art processes, to specify new applications including functionality.</p>
WA4.2.4	Advanced rules and business logic supporting high efficient freight operations	<p>Research, specification and development of advanced rules and business logic for freight supporting new traffic management principles.</p> <p>These business service application modules are foreseen be implemented as a business application tool connected to a future data silo. However the design of these modules has to be flexible to be also reused in a freight operations management system if required.</p> <p>All specification work will be done collaboratively between the partners participating in this task.</p> <p>A set of functional complementary SW module prototypes TRL3/4 including interfaces will be developed and tested.</p> <ul style="list-style-type: none"> <li>• Prototype demonstrating freight functionalities and resource mapping for the management of dangerous goods,</li> <li>• Prototype demonstrating real-time goods tracking service,</li> <li>• Prototype for optimal crew change strategies.</li> </ul> <p>This task will further include activities to develop concepts to handle annual and ad-hoc timetable planning with operations and to study implementation of these concepts into practice for selected strategies.</p>

Task	Task Name	Task Description
WA4.2.5	Plug-ins to enable integration of services	<p><u>WA4.2.4.1 Plug-ins needed to integrate TMS and freight operations.</u> Specification and development of a set of plug-in application to gain:</p> <ul style="list-style-type: none"> <li>• Data from Freight Operations Business Server (integrated in Data Silo or stand-alone) and to send the processed results via integration layer to the TMS to be integrated into the process.</li> <li>• Data from TMS business server (integrated in data silo or stand-alone) and to send the processed results via integration layer to the freight operation management system to be integrated into the process.</li> </ul> <p>Without the plug-ins the integration between TMS and freight operations cannot be achieved. All specification work will be done collaboratively between the partners participating in this task. A set of functional complementary prototypes TRL3/4 including interfaces will be developed and tested</p> <ul style="list-style-type: none"> <li>• Complementary prototypes demonstrating basic functionalities (Type 1 and Type 2),</li> <li>• Prototype presenting the function mapping part of such a plug-in to generate data from freight business server needed to manage dangerous good transportation on TMS level,</li> <li>• Prototype addressing driver advisory functionality for freight trains applying driver advisory principles.</li> </ul> <p>This task will further include activities to develop concepts to link freight operation status data with the management of annual and ad-hoc timetable planning. Focus herein will be on operations, best practices and state-of-art implementation of concepts into practice.</p> <p><u>WA4.2.4.2 Plug-ins needed to integrate TMS and Asset Management.</u> Specification and development of a plug-in application to gain:</p> <ul style="list-style-type: none"> <li>• Data from asset management server (integrated in data silo or stand-alone) and to send the processed results via integration layer to the TMS to be integrated into the process.</li> <li>• Data from TMS server (integrated in data silo or stand-alone) and to send the processed results via integration layer to the asset Management Centre to be integrated into the process.</li> </ul> <p>Without the plug-ins the integration between TMS and asset management cannot be achieved. All specification work will be done collaboratively between the partners participating in this task. A set of functional complementary prototypes TRL3/4 including interfaces will be developed and tested</p> <ul style="list-style-type: none"> <li>• Complementary prototypes (Type 3 and Type 4) demonstrating basic functionalities,</li> <li>• Specific prototype/functionality demonstrating ability to utilise risk-based infrastructure condition data,</li> <li>• Specific prototype (Type 4) demonstrating cooperative workflows with train operating company during resolution of larger disturbances.</li> </ul>

Task	Task Name	Task Description
WA4.2.6	Demonstrator	<p>Proof and validate the targeted achievements of the integrated (cross cutting) system to exchange status information with different services and integrate those data in the processes.</p> <p>The result will be a demonstrator platform integrating the developments under W4.2 into the generic framework specified and developed under TD2.9 and the related generic business service applications developed under TD2.9, TD3.6 and TD5.2.</p> <p>The integration work will be done collaboratively between the partners participating in this task</p> <p>This task will include an evaluation of the achieved results from an Infrastructure Manager perspective</p>

Figure 126: WA4.2 Gantt chart

WA4.2- Integrated Mobility Management (I2M)		2016				2017				2018				2019				2020				2021 - 2024			
Task	Description	Q1	Q2	Q3	Q4	Q1	Q2	Q3	Q4	Q1	Q2	Q3	Q4	Q1	Q2	Q3	Q4	Q1	Q2	Q3	Q4	Q1	Q2	Q3	Q4
WA4.2.1	Technical assessment and integration																								
WA4.2.2	Upgrade of integration layer																								
WA4.2.3	TMS application supporting high efficient freight op.																								
WA4.2.4	Advanced rules and business logic																								
WA4.2.5	Plug-ins to enable integration of services																								
WA4.2.6	Demonstrator																								

The estimated total budget for WA4 is around 14.7 M€.



## 6.5.5. Work Area 5 Energy and Sustainability

### 6.5.5.1. Sub work area 5.1 Energy

#### Concept and objectives

The overall objective of WA5.1 is to reduce the operational costs through a reduction of energy consumption.

The end result of WA5.1 has the added value of a standardised methodology for estimation of energy consumption by simulation and measurement enabling the standardised specification of energy efficient railway systems.

Energy is one of the key concerns in the ambitious goal to increase the competitiveness of railway transport, to boost the competitiveness in the European manufacturing rail sector and to limit environment impact.

Energy efficiency simultaneously enables improvement of railways excellent environmental balance by cutting down CO<sub>2</sub> emissions and to improve the economic business model of the Railway Transport sector by reducing the cost of energy, making train travel more affordable and thus promoting the modal shift to rail.

Shift2Rail has included energy as a major contributor to the COMPETITIVENESS (LCC) KPI (WA2).

This is in phase with the European Commission and ERRAC targets to promote energy savings as well as reduction of CO<sub>2</sub> emission in the whole railway systems including operations, infrastructure, rolling stock, sub-systems (like traction and running gear) and components.

The objective of the Energy and sustainability WA is:

- To achieve and assess the overall energy reduction on all Technical Demonstrators (TD) and System Platform Demonstrators (SPD)
- To demonstrate the cost effectiveness energy saving features
- To help and support all energy saving related work across the Innovation Programmes (IP) and TDs
- To stimulate the emergence of pre-normative texts when needed to pave the way toward a European shared understanding of energy figures in railways.
- To link energy and sustainability actions with existing initiatives outside Shift2Rail in order to align understanding and positions from railways and energy stakeholders

#### Impact

Apart from the direct impact on the Shift2Rail KPIs (WA2), the activities will directly bring significant environmental benefits.

The business benefit, markets and deployment are in the heart of energy expert day to day work during the whole duration of Shift2Rail as we will evaluate regularly all potential deployment of new solutions developed in TDs and IPs. The technical benefit as well as the economic potential will be evaluated.

Barriers and obstacles will also be evaluated and the way to solve the bottlenecks in such domains will be proposed.

Experts will also evaluate the framework conditions, existing regulations and standards in order to propose progress allowing new solutions to be deployed on the markets.

### **Linkage and alignments with Master Plan**

Table 73 shows the links between WA 5.1 and the objectives of the Shift2Rail Master Plan.

**Table 73: WA5.1 links to Master Plan objectives**

Master Plan objectives		Addressed by:
Reduced system costs	MP5 Reduced operating costs	Reduced energy consumption
	MP6 Externalities	
Simplified business processes	MP9 Improved standardisation	<ul style="list-style-type: none"> <li>Standardised methodology for estimation of energy consumption by simulation.</li> <li>Standardised methodology for measurement of energy consumption</li> </ul>

### **Relevant EU projects, national projects and past experience**

Former EU projects like RailEnergy (2006-2010 with a scope of main lines), Osiris (ongoing, on the scope of urban railway systems) and Merlin serve as a baseline with respect to methodology development and KPI definition, but their results will be significantly amplified and extended.

### **Implementation of the work programme**

High speed, regional, urban and freight trains missions, services and markets have some different characteristics and constraints that could lead to different technical solutions for energy savings.

Technology developments to be carried out cover many innovative solutions as propulsion components, lightweight car bodies and low resistance running gears. Smarter use of existing technologies is covered by improved signalling systems that reduce unintended stops on high-traffic lines and provide energy-efficient driver assistance. New infrastructure of energy distribution will also lead to benefits on energy consumption. All potential new solutions have to be evaluated.

A transversal experts group will be created (CCA energy group). These experts will provide their know-how in many TDs and IPs especially to translate local Energy Performance Indicators (PI) into the Shift2Rail macro indicator.

Figure below shows how WA5.1 will act via three tasks on the Shift2Rail initiative.

**Figure 127: WA5.1 tasks interaction within Shift2Rail.**

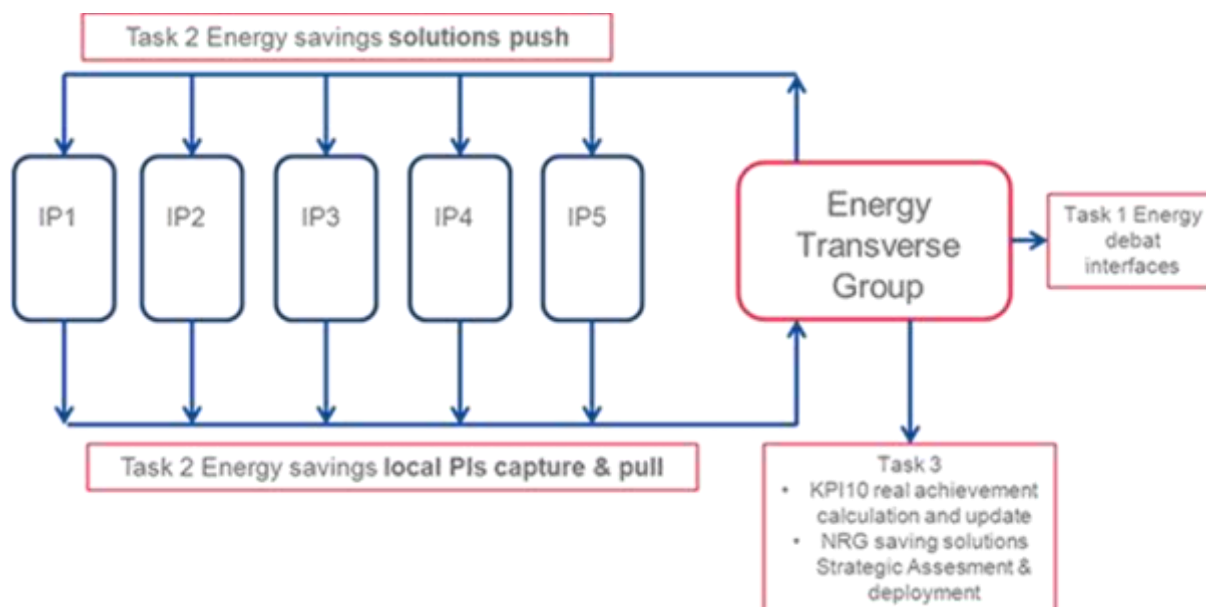

The three tasks defined within WA 5.1 will allow at the end of Shift2Rail to deliver quantified energy performances of addressed railway Integrated Technical Demonstrators (ITD) with the following key information for economic or political decision makers:

- Achievable energy savings technical solutions across the whole levels of SPDs
- Roadmaps on foreseen products (above TRL6-7 technology demonstrators) potential deployment
- Estimated development costs of the industrialised solutions
- Estimated investment costs for operators & infrastructure managers
- Technical risks in case of technology breakthrough that could hinder the solution
- Potential barriers to deployment linked to business rules of stakeholders and/or cultural and standard barriers.
- Establishing favourable norms & regulations environment for those products that are developed within Shift2Rail parallel to the product development.

Innovation and basic research will take place in the development of the holistic energy model where the local TDs achieved savings are converted into system savings, respecting the interactions between the until then isolated TDs.

The pure method development is foreseen to be finished after approximately 2 years, at which point in time the Interface with external groups (CENELEC and other) can be closed via transmitting our



results to them. However, the internal cross-interference matrix work has to continue inside task WA5.1.2 (see below).

The work plan for WA5.1 is presented here after in Table 74 and the Gantt chart, in Figure 128.

**Table 74: W5.1 task details**

Task	Task Name	Task Description
WA5.1.1	Interface with other Shift2Rail Groups and External Energy Groups	<p>Goals:</p> <ul style="list-style-type: none"> <li>• A strategic view integrating European transport and environment policies and recommendations</li> <li>• An interface on norms &amp; regulation inputs to "JTI regulation and standardisation council" for energy matters</li> <li>• A marketing understanding on energy related questions: existing and future "business rules" to allow emergence of new low consumption solutions between energy stakeholders (Industry, Operators, IM, Energy providers, etc.)</li> <li>• A common approach on eco-labelling, including inputs from European R&amp;D projects <ul style="list-style-type: none"> <li>○ Support modal shift by linking eco-labelling to multi-modal habit changes for global energy /CO<sub>2</sub> savings for Europe</li> </ul> </li> </ul> <p>WA5.1 will cooperate on energy norms, state of the art and future development, energy strategic views and needs.</p> <p>The energy requirements for high speed, regional and freight trains resulting from existing normative specifications, guidelines and other stakeholders are analysed. This includes the results of Roll2Rail and is done in order to derive a strategy and future rules for the specification of energy efficiency.</p> <p>Further recommendations on urban train norms and regulations are developed.</p> <p>Pre-normative work will provide energy related marketing studies and eco-labelling proposals.</p> <p>Energy efficient technologies and strategies from a whole life cycle approach will be analysed.</p> <p>Additional expertise is needed through <b>open calls</b> from Urban Operators, research laboratories, Infrastructure Managers and Standardisation Bodies concerning the following topic: Energy requirements for urban rail traffic</p>
WA5.1.2	Energy calculation methodology	<p>Technical support to TDs / Development of energy calculation methodology</p> <p>To bring technical support to TDs by the energy experts of the CCA Group, provide an energy calculation methodology with agreed boundary conditions and to consolidate and integrate the energy related results.</p> <p>The objectives are to review tasks carried out in the IPs to determine their relationship with energy efficiency. Once the energy related tasks have been identified for each IP, the energy CCA group will analyse them in order to provide its counselling and assessment expertise in the energy efficiency area. The output will not only be on supervision and control, but will also identify research areas worth studying. In this way, the cross-cutting activity will act as a link between different research activities on energy efficiency inside the Shift2Rail framework.</p> <p>These are the objectives:</p> <ul style="list-style-type: none"> <li>• Bring external needs and framework from task WA5.1.1 to help TD leaders to push suitable energy savings approaches on prototypes</li> </ul>



Task	Task Name	Task Description
		<p>developments for all IPs.</p> <ul style="list-style-type: none"> <li>• To support the TD leaders in the definition of local performance indicators (PI's) of their TDs with respect to energy savings</li> <li>• To supply the TD leaders with methodologies to assess the energy savings</li> <li>• Capture the progress done at local level (Tasks, TDs, IPs) on energy savings</li> </ul> <p>Energy savings reference framework &amp; state of the art are elaborated and energy savings solutions are pushed.</p> <p>The cross interference matrix is developed for identifying the energy saving potential technologies within Shift2Rail developments.</p> <p>WA5.1 will interact with TD leaders to apply the specifications and requirements from task WA5.1.1, push energy efficient solutions and follow up on the impact on energy consumption. WA5.1 will support the TD leaders in the definition of local performance indicators of their TDs with respect to energy savings and supply the TD leaders with methodologies to assess the energy savings for the traffic segments</p> <ul style="list-style-type: none"> <li>• high speed</li> <li>• regional</li> <li>• urban transport including light rail and metros</li> <li>• freight</li> </ul> <p>WA5.1 will support identification of the TDs impact on energy consumption by developing a technical questionnaire to assess energy saving potentials of the Shift2Rail developments. Scalability of the developments and portability to other TDs and SPDs will be the questionnaire's main focus to provide a substantial basis for building the cross interference matrix.</p> <p>WA5.1 will support a virtual customer acceptance procedure to validate progressively energy management and / or real subsystem in a secured controlled global railway environment to validate the real energetic benefits, maintenance aspects, cost-effectiveness, etc. of energetic systems with agreed boundary conditions and free from unnecessary assumptions.</p> <p>A generic systemic methodology would be applied to other IPs and would help TDs on their respective topics. IP1 and IP3 have already been targeted as relevant themes for methodology. However, this methodology is surely not closed to any other subject proposed by other Shift2Rail members.</p> <p>Operational scenarios for high speed, regional, urban and freight traffic will be defined. WA5.1 will share and analyse existing measured energy data for base lining purposes.</p> <p>Additional expertise is needed through <b>open calls</b> from Urban Operators, Railway Undertakings, Sub-suppliers, Research laboratories, Infrastructure Managers, Standardisation Bodies concerning the following topics:</p> <ul style="list-style-type: none"> <li>• Contribution to the development of an energy calculation methodology</li> <li>• Adoption of an existing energy simulation tool from a further European project to the requirements of Shift2Rail.</li> </ul>

Task	Task Name	Task Description
WA5.1.3	Assessment of energy improvement	<p>Integration of IPs and TDs local result for global energy KPI achievement of Shift2Rail</p> <p>The goals of this task are to:</p> <ul style="list-style-type: none"> <li>• Integrate results provided by the TDs via task WA5.1.2</li> <li>• Evaluate and update twice a year the Shift2Rail energy KPI. To do this, sum all energy savings progress with the suitable methodology.</li> <li>• Deliver final energy related results achieved by Shift2Rail for the four SPDs.</li> <li>• Provide the overall energy KPI monitoring in WA2.</li> </ul> <p>All partners will work together on customisation of KPI and modelling, build energy “state 0 baselines of all SPDs”, “state 1 energy quantification &amp; Shift2Rail energy conclusions”.</p> <p>WA5.1 will define the methodology to translate low level local energy performance indicators PIs progress into KPIs on SPD level. The -proprietary tools of the working area participants and those developed in collaboration via open calls will be used to quantify improvements.</p> <p>A state 0 will be created as a basis to quantify the progress towards KPI objective and finally, create the state that could be achieved, if solutions are implemented for</p> <ul style="list-style-type: none"> <li>• High speed</li> <li>• Regional</li> <li>• Urban transport including light rail and metros</li> <li>• Freight</li> </ul> <p>Methodology development will be performed if needed.</p> <p>WA5.1 will provide a simplified holistic energy model (“well-to-tank” or “well to catenary”) to allow consideration of power generation during translation from local to global KPI.</p> <p>Evaluation of total energy savings for high speed, regional, suburban and freight traffic is supported by WA5.1.</p> <p>Specific expertise is needed through <b>open calls</b> including: Urban Operators, Industrials, Suppliers, Research laboratories, Infrastructure Managers concerning the following topics:</p> <ul style="list-style-type: none"> <li>• Participation or validation the conclusions on Energy KPI for all SPDs</li> <li>• Estimation of the energy consumption twice a year</li> <li>• A study for analysing the losses within the traction chain for different traction systems</li> <li>• Application of innovative storage systems and innovative motor technologies for railways</li> <li>• Development of a global vision of energy in railways including smart management of railway networks</li> </ul>





### **6.5.5.2. Sub Work Area 5.2 Noise and Vibration**

#### **Concept and objectives**

Noise and vibration (N&V) represent one of the biggest environmental challenges for the railway. The end result of this work area is to reduce the annoyance and exposure to noise and vibration related to the railway sector in Europe.

To facilitate effective noise and vibration management, it is crucial to apply an overall system approach and enable efficient mitigation actions. To overcome this challenge it is essential to have commonly agreed and validated simulation tools to be able to e.g. correctly quantify and rank the N&V sources before deciding on costly measures for their mitigation. A proper ranking for relevant combinations of rolling stock, infrastructure and running conditions together with methods for calculating cost effectiveness of mitigation actions will considerably improve the current situation.

Moreover, the added value of WA5.2 is to provide the necessary system approach and leverage the results from all the IPs by applying effective noise control in the different technical demonstrators.

Population in the vicinity of railways no longer accepts the increasing N&V annoyance while on the other hand a shift to rail-traffic is important for environmental reasons.

Reduced speed limits or night-driving bans to mitigate N&V annoyance are now increasingly implemented. Such measures reduce the transport capacity on the main railways in a non-acceptable way. Reducing N&V annoyance is therefore essential and a key-factor for the success of European concepts and strategies to provide a sustainable and high-capacity transport system.

The ERRAC Noise and Vibrations Roadmap 2030 has defined the goals for future research:

- By 2030 noise mitigation measures will be integrated naturally in all relevant processes of the railway.
- The European railways will strive towards that noise and vibrations are no longer considered a problem for the railways and their neighbours, meaning that noise levels are socially and economically acceptable and allow for 24-hour passenger and goods operations by 2050.

The end results of this work area should also contribute to strengthen the railway sector by improving passenger comfort, facilitating efficient product development and promote technology transfer from other sectors. Railway vehicles are normally developed and produced in small series with extremely long life-cycles compared to other vehicle types, such as cars, trucks and buses. The small series together with interests to reduce development times, call for accurate and robust prediction tools to limit the need for prototypes and testing. Improved as well as novel approaches for virtual design and testing combined with introduction of new technologies for noise and vibration mitigation in a European context is necessary for the success of the future railway system.

The overall objective and methodology is twofold:

- Develop practically useful methods for predicting noise and vibration performance on system level including both rolling stock infrastructure and its environment. With an accurate ranking

and characterisation of each contributing source it will be possible to optimise cost benefit scenarios as well as taking exposure and comfort into account.

- Ensure that N&V needs are properly considered and integrated in all relevant Technology Demonstrators within the different Innovation Programmes of Shift2Rail

The work area will include exterior noise, interior noise and ground vibration. It will particularly focus on four areas: i) solutions and methods in the freight segment to reduce disturbance for residents; ii) urban area sound propagation and impact on residents to support future updates of TSI for noise; iii) interior N&V comfort and attractiveness for passengers and iv) auralisation and visualisation of N&V scenarios for future railway systems, including levels of exposure as well as annoyance and perception perspectives.

**Figure 129: work structure**

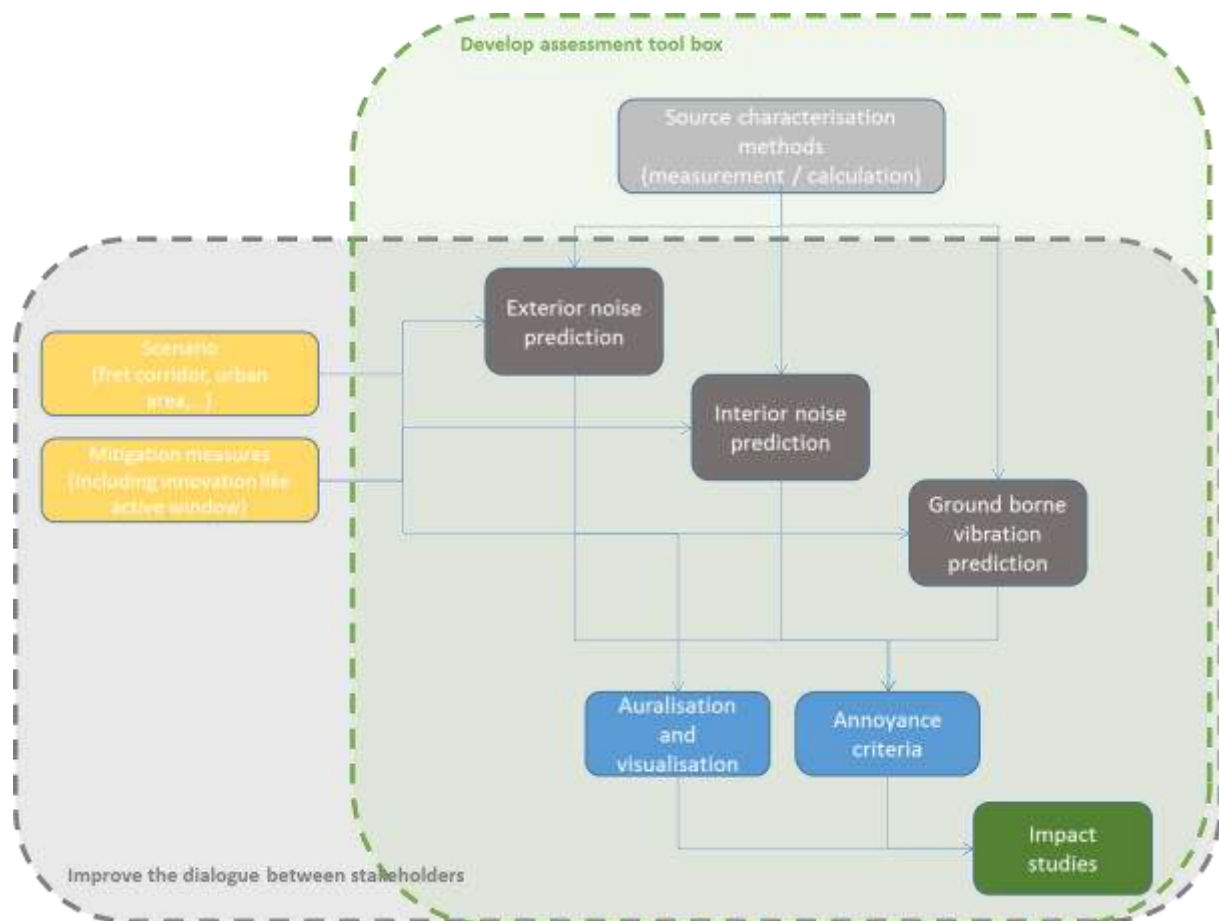

The framework structure of the WA5.2 is depicted above and further developed in the task list.

In the core of this framework are predictive schemes for interior and exterior noise as well as ground vibrations. Such schemes in combination with accurate and robust source assessment methodology are required to assess the effect of noise mitigation measures as well different scenarios for effective noise management on system level. This in turn is a requisite to arrive at cost effective noise control solutions on system level. Within the project also auralisation methodology and novel annoyance

criteria are developed for assessment of the expected impact of solutions developed on vehicle and system level as well as on European level.

### Linkage and alignments with Master Plan

Table 75 shows the links between WA 5.2 and the objectives of the Shift2Rail Master Plan.

**Table 75: WA5.2 links to Master Plan objectives**

Master Plan objectives		Addressed by:
Improved services and customer quality	MP2 Enhancing capacity	Avoid limiting capacity due to restrictions on noise
	MP3 Customer experience	Increased passenger comfort and attractiveness with improved interior noise and vibration
Reduced system costs	MP4 Lower investments costs	More cost efficient NoV mitigation methods, do proper ranking and system level analysis
	MP5 Reduced operating costs	
Simplified business processes	MP9 Improved standardisation	Improve TSI Noise approaches for reduced annoyance
	MP10 Simplified authorisation	Develop simulation methods for virtual design and testing

### Relevant EU projects, national projects and past experience

The following projects have been identified as relevant to the work to be carried out in WA5.2

- **Roll2Rail (WP7 Noise):** The Roll2Rail “lighthouse” H2020 project, is oriented to pre-start some of the work lines of Shift2Rail. WP 7 in R2R is treating noise including experimental methods to separate the vehicle and track contributions for the rolling noise part. Results of Roll2Rail will be incorporated to WA5.2 within the first 12-18 months after the start of Shift2Rail.
- **Acoutrain:** This project was dedicated to simplify and improve the acoustic authorisation of new rolling stock, in particular relating to the TSI (Technical Specifications for Interoperability) Noise. Acoutrain was a three-year project that began in October 2011 with a budget of around three million Euros. The work was mainly focused on developing methodologies and to define a possible virtual noise process for authorisation. Virtual certification procedures were developed and applied to e.g. the authorisation of a regional train. The virtual test results were benchmarked to experimental results. It is shown that detailed characterisation of installed sources is crucial to the success of virtual certification. This work will be continued in Task W5.2.3 on exterior noise with the target to advance the state of art.
- **RIVAS** (“Railway induced vibration abatement solutions” 2010-2013): RIVAS was a holistic approach to ground borne vibration due to railway traffic with the aim of reducing annoyance of track side residents. The work included basic research for improved understanding of excitation mechanisms as well as analysis various design parameters such as: vehicle level mitigation



measures, rolling stock maintenance, track design, track maintenance, subgrade engineering and the transmission path within the railway infrastructure. Numerical modelling, was used for elaborate parametric studies and also supported by field tests for verification and validation of predicted vibration reduction. Results from the project have clearly shown that the effectiveness of vibration mitigation measures are highly depending on the type of train and train speed, the type of track, the soil conditions and even the type of buildings next to the track.

- **SILENCE IP** – In this project a source ranking for urban vehicles was made. Only traction equipment for urban transit was studied. An analysis of the noise contributions was done for two cases: a traction motor of a tramway and a diesel cooling unit. For the case of the traction motor an experimental characterisation was done but no simulation methodologies for electromagnetic-forces and associated noise were developed. Neither were proposed solutions tested in a real prototype. In the case of the cooling unit an application with several prototypes was chosen but the design methodology applied did not include thermal and acoustic constraints.

This work area will extensively use the research results from the above projects as input and for the new development.

#### **Implementation of the work programme**

To reach the objectives described above a number of task and sub tasks are defined and detailed in the present section. They will assure that N&V aspects are properly considered and integrated in all relevant Technology Demonstrators within the five different Innovation Programmes and also that resources are used in a coordinated and efficient way to deliver the N&V targets

The main measure for success is that the acoustic design targets are reached as defined in each Technical Demonstrator for subsystems within both the infrastructure and vehicle parts. These targets will be defined at the early project stages to enable the desired overall noise reduction of 3 to 10 dBA to be achieved depending on the combination of infrastructure and rolling stock and on the particular running conditions. It should, in this context, be noted that reducing a number of sources to half, in number or source strength, will result in a 3 dBA decrease of overall noise level.

Moreover, methodologies for evaluation, simulation and impact analysis of the research work undertaken will be developed, aligned and co-ordinated. Efficient integration of the N&V activities is a crucial objective in view of the significance of system design interfaces for N&V transmission.

A specific objective is to monitor that all N&V sources and transmission paths, and their associated abatement needs in the different TDs of Shift2Rail, are properly addressed to achieve the acoustic system level design targets for both infrastructure and rolling stock.

The topics included in WA5.2 are covering basic research and dedicated innovative solutions as well as building on a solid basis of existing technologies and methods to be improved.

In particular it is of great importance to have resources to carry out a scientifically based systematic validation of methodologies and acknowledge and point out inherent uncertainties in the state of the art.



Innovative elements are included in a wide range of topics from novel capacities for auralisation and visualisation for the public of progress in the N&V areas, structure borne and aeroacoustic simulations with advanced numerical method for a virtual design as well as active technologies and new materials.

Open calls for approximately 30 % of the budget will be dedicated to open calls to develop, validate and implement new enhanced simulation models in all tasks except 1 in the list above.

The work plan for WA5.2 is presented here after in Table 76, and the Gantt chart, in Figure 130.



**Table 76: WA5.2 task details**

Task	Task Name	Task Description
WA5.2.1	Technical assessment and integration on system level of N&V tasks	<p>The purpose is to identify all N&amp;V relevant components in the demonstrators included in S2R TDs and further to set and follow up N&amp;V targets for each contributor to achieve an optimal result on overall system level.</p> <ul style="list-style-type: none"> <li>Identify all N&amp;V relevant systems included in Shift2Rail TDs and establish contact for continuous communication with TD and IP leaders</li> <li>Identify combination for N&amp;V scenarios to be considered: combination of infrastructure, running condition and rolling stock details for the 4 SPDs (high speed, long-distance passenger trains, regional and freight). These N&amp;V scenarios will link to the traffic scenarios to be defined in task WA5.2.2 below.</li> <li>Set first set of targets and baseline for N&amp;V in all TDs together with TD leaders based on selected scenarios from above. Use existing methods and estimates. This will build on the work performed in former EU projects as Acoutrain, RIVAS and Roll2Rail.</li> <li>Follow up and optimise N&amp;V targets for TD and system level throughout the Shift2Rail project. Refine N&amp;V targets by using the new models developed in tasks WA5.2.4, WA5.2.5 and WA5.2.6. Establish and follow up action plan if there are indications that TD targets are at risk.</li> <li>Coordinate resources and competences for N&amp;V work in TDs with TD leaders as required.</li> </ul>

Task	Task Name	Task Description
WA5.2.2	Evaluation and monitoring of impact on traffic noise scenarios of Shift2Rail innovations	<p>Actions applied for mitigation of noise and vibration in the railway system today are strongly sub optimised. This is partly due to a lack of a consistent system approach, including effective source ranking, but also to the lack of tools to relate the predicated reduction of noise levels to costs associated.</p> <p>As the base-line for noise impact assessment, operational reference scenarios for each marketing segment (high speed, long-distance passenger trains, regional and freight) are developed in task WA5.2.1. These scenarios are used as a base line to monitor and evaluate the effects of proposed mitigation plans including cost benefit ratios compared to state of the art for realistic conditions.</p> <p>With respect to noise monitoring, parts of the TEN (Trans-European Transport Network) rail freight corridor A “Rotterdam-Genoa” are suggested as reference track for evaluating the different noise mitigation effects of the different technologies and their combination for a freight case. Furthermore, a long term vision on the expected traffic increase and its impacts on different scenarios change will be given.</p> <p>Existing tools will initially be used to evaluate the effects of the technologies developed in Shift2Rail. Although the main noise annoyance, and associated opposition against railways is caused by freight traffic, all sorts of passenger traffic could be considered within the different scenarios defined.</p> <p>The current state of the art noise mitigation activities with their effects will be used to describe the reference state or base line. Afterwards, the Shift2Rail activities are evaluated with respect to their relevance to noise emissions. Where required, the needed parameters for the simulation are derived in close cooperation with the other Shift2Rail partners within the different IPs. On the basis of these parameters, scenarios are calculated and evaluated in terms of their impact on noise emissions as well as the costs of mitigation measures.</p> <p>The analysis will be completed by a specified cost benefit analysis, so that as a final result a unified assessment system for the evaluation of the most effective noise reduction technologies is available. This will serve railways as well as legislation authorities and not least the EC to find the most profitable and sustainable technologies and to define optimised noise mitigation strategies in the future.</p> <p>The proposed working process for this task starts with identifying traffic scenarios to be considered. This will include particular scenarios for e.g. freight lines, urban areas as well as parking modes. Thereafter, models for cost-efficiency calculations for e.g. freight corridors will be created and validated. An evaluation of the influence of Shift2Rail activities and TDs on the N&amp;V emissions, including their costs, will be carried out based on traffic scenarios, e.g. traffic loads on the Rotterdam-Genova freight corridor. Here, exterior noise prediction tool and cost benefit models will be applied. The goal is to find the most effective measures on rolling stock/infra-structure to reduce levels at façades of buildings connected with solutions within other IPs. Annoyance effects for the residents should be included. Finally, the impact of the activities, for a example a freight corridor for different traffic scenarios, is calculated and evaluated in terms of percentage of annoyed people. The evaluation is carried out for different potential legislation schemes, and their specific cost benefit ratio.</p>

Task	Task Name	Task Description
WA5.2.3	Exterior noise simulation model and separation techniques	<p>There are two goals:</p> <ul style="list-style-type: none"> <li>• to further develop and validate simulation tools for exterior noise modelling</li> <li>• to extend the research started in Roll2Rail related to separation techniques, separating rolling noise vs. vehicle noise, in order to optimise and standardise the techniques developed. Include separation from other sources other than rolling noise (e.g. drive systems) and consider different kind of vehicles (commuter trains, high speed, etc.).</li> </ul> <p>Exterior noise simulation models are applied today for different reasons by train manufacturers, operators and infrastructure owners. For manufacturers, the main purpose of the simulations is to check the compliance of noise emissions of a specific rolling stock in a standardised measurement condition while for operators and infrastructure owners the main interest is to assess the environmental noise impact of a specific rail network assuming certain traffic conditions. Several environmental models have been developed in the past, for example the CNOSSOS model, that allows to perform environmental noise assessments but there is a lack of models to determine specific noise contribution of a particular rolling stock in a detailed urban scenario or complex topography. For this reason it is needed to extend and/or to develop tools to cover those scenarios.</p> <p>On the other hand, several tools were considered during the Acoutrain project and even one developed to cover manufacturer's needs. Nevertheless, those tools were only covering limited TSI cases with respect to the speed and type of rolling stock. Therefore, it is needed to further extend and also verify those tools to represent relevant TSI cases and other scenarios as often expressed in contracts for new rolling stock. For this purpose, the integration of sources will have to be considered including the effect of, for example, skirts and fairings.</p> <p>Separation techniques to obtain the contribution of vehicle noise vs infrastructure in a TSI scenario are being benchmarked in the Roll2Rail project. The output of Roll2Rail will be a selection of the best strategies for the separation but only related to rolling noise. In Shift2Rail, the objective is to confirm and extend existing methods to assess the contribution of other sources than rolling, such as aeroacoustics and traction, and this way increase the range of utility of the methods. A wider range of railway vehicles, in relation to Roll2Rail will also be studied. Additionally, a possible future standardisation of the methods will be considered.</p>

Task	Task Name	Task Description
WA5.2.4	Interior noise simulation model	<p>The goal is to further develop and validate prediction methods for interior noise. Both transmission models and source representations are addressed.</p> <p>It is of great importance to improve the attractiveness and comfort for the end customers, namely the passengers, in the European railway system to stay competitive versus other modes of transportation. Important factors are the quality of the sound and vibration environment on-board rolling stock. On all customer specifications of new rolling stock the requirements of interior noise are extensive and demanding.</p> <p>To reach the N&amp;V design targets, validated models to simulate the interior noise with good accuracy are necessary. In the vehicle design process such models are used to: i) rank and quantify the relative importance of sources and transmission paths, ii) set requirements on car-body sub-systems and sources given the vehicle level noise requirements and finally iii) identify and quantify the effect of design measures to reach the acoustic requirements. The latter use gives input to decision making in the vehicle design process to arrive at cost effective design solutions. Typically, effective acoustical design solutions are in conflict with space and weight requirements. Therefore, the models developed should be able to perform parametric studies with respect to key design parameters, such as weight and space, such that they can be applied in structural optimisation schemes.</p> <p>Development of transmission models for applications as above based on existing numerical, analytical, statistical and experimental methods for air- and structure-borne noise is addressed. A first step is to broadly assess the potentials and limitations of existing methods. A second step is to advance the state of art regarding prediction of sound transmission to the interior in the full audio frequency range. Focus will be on methods that can model the space and frequency average of sound levels in relevant passenger positions and correctly assess associated source contributions.</p> <p>To meet acoustic, thermal and structural constraints of car-body elements at minimum space and weight, multi-disciplinary and multifunctional optimisation will be applied for relevant car-body elements, typically floor structures. Another novel scenario is to replace, or complement, today's energy based requirements on interior levels with more sound quality oriented indicators. This has the potential to at the same time improve comfort and attractiveness and reduce cost and weight.</p> <p>To integrate results from different predictive and experimental methods, a framework needs to be developed to handle relevant sources and the associated transmission path to receiver positions. In particular structural sources must be addressed (see task WA5.2.3). The methods chosen within the framework should be suitable for supporting the vehicle design process, as explained above and in particular assess the effect of noise control solutions developed within the TDs. Specification of input data requirements for sources and sub-assemblies addressed in the TDs should be carried out in task WA5.2.6.</p> <p>Careful step-wise validation of the simulation methods are planned, both for existing and novel methods. Experimental validation of models on relevant train structures is required whereas numerical benchmarking is promoted as intermediate steps. Validation schemes should be focused on the correct assessment of key design changes related to noise control. A final validation on a fully furnished car-body will be carried out with relevant excitation.</p>

Task	Task Name	Task Description
WA5.2.5	Ground Borne Vibration Prediction Methods	<p>The goal is to develop a prediction scheme and a model which allows performing ground-vibration predictions within a holistic model from source to receiver suitable for use in the vibration part of environmental prediction studies.</p> <p>Within the last decades not only noise, but also ground-borne noise and vibrations are more and more in focus not only by the people annoyed but also during the planning process and the legislation phase of new or upgrading projects of railway lines. Here prediction studies become an inevitable part of the environmental evaluation and legislation. In contrast to noise studies, no common used holistic prediction model for ground-borne vibration is available or yet accepted by environmental legislation authorities. Up to now, the prediction is carried out by means of complex numerical methods and expensive measurements. It depends strongly on other specific experience of the consultant teams and their background.</p> <p>To predict vibration levels before building new railway lines using simulation models rather than expensive measurements, the development of a new methodology with a unified European understanding is necessary. Such models can also be used to identify and quantify the effect of measures to reduce N&amp;V levels. State of the art prediction models are judged to be not mature enough for meeting these needs and accordingly not ready to be used by end-users.</p> <p>The work to be carried out includes i) survey present assessment procedures and standards in Europe for vibration impact studies (including structure-borne noise), ii) specify a new software frame (to cover scenarios as defined in WA5.2.2) for prediction of vibration and ground-borne noise (continuation from RIVAS), iii) develop a software tool with a validated calculation core and a user-friendly graphic interface (partly based on existing vibration simulation models), iv) practical software test for different applications and finally v) validation of the method by comparison to numerical results and measurements.</p>

Task	Task Name	Task Description
WA5.2.6	Sources and sub-assemblies characterisation methodologies	<p>The objective is to obtain accurate input data for the simulation models in WA5.2.3, WA5.2.4, WA5.2.5 and a systematic and physically correct procedure for specifying the acoustic characteristics of the sources.</p> <p>There are several noise sources in a train that generate different type of noise depending on the transmission path of the acoustical energy to the receiver. Those sources could be related to equipment that the manufacturer buy from external and/or internal suppliers. Also some parts of the train (windows, doors, gangways, floors) are normally delivered from external suppliers. To fulfil interior noise requirements and to improve the comfort of passengers, several vibroacoustics targets are set to the different equipment and parts. On the other hand the setting of vibroacoustic targets greatly depends on the methodology used for interior noise prediction and it is common to find difficulties to establish targets accepted by suppliers because the methods are neither fully validated nor standardised. This finally drives cost for purchased equipment and sub-systems due to the difficulty for suppliers to standardise their products which is translated in higher costs. (Specific tests for each manufacturer, non-compliance non detected etc.). To reduce all those inconveniences different methodologies for the specification of sources and parts will be proposed and studied. Sources and parts measured with those methodologies will be used as input for interior/exterior noise models used in task WA5.2.3 and 4 WA5.2.</p> <p>The definition of relevant input data for simulation models and an accurate procedure for specifying standardised characteristics of the N&amp;V sources is the main goal in this task. Methodologies for specification are required for different type of sources including their different transmission paths (air-borne and structure-borne) together with methods for the specification of train sub-assemblies will be taken into account (floors, gangways, doors, etc.). A first step will include a study of the state-of-the-art of current methodologies with a compilation of practical examples of current applied methodologies. From that initial study a SWOT analysis will be obtained to point out the necessary improvements in the methods. Using the initial analysis, a further development of current methodologies towards innovative approaches for determining structure-borne and air-borne noise characterisation of sources and train sub-assemblies will be done. Later a validation either numerically, analytically or experimentally of the methods in controlled environments and the application of the methods at component and train sub-assembly level will be carried out. In parallel to the previous activities a collection of information from sources and train sub-assemblies available in different TDs will be done. The proposed vibroacoustic methodologies for specifications will be implemented in the requirement setting for the different TDs.</p> <p>Vibroacoustic sources are divided in air- and structure-borne sources. Air-borne sources characterisation standard measurement methods will be further developed and adapted to give relevant information to prediction models of tasks WA5.2.3 and WA5.2.4, including their validation. For structure-borne sources the workflow will go from the current state of the art analysis and current practices to an evolution of the current methods in order to specific different kind of sources (bogie, motors, gearbox, equipment in cubicles,...) The new methodologies will be validated with tests in equipment in test bench and at train level. A best approach for the characterisation will be finally agreed. The modelling of sources will be refined and adapted based on detailed measurements of real sources</p> <p>For transmission loss of partitions, comparison between standardised measurements in lab and in situ measurements should be done in order to adapt the current testing methods.</p>

Task	Task Name	Task Description
WA5.2.7	New methodologies and technologies	<p>In order to achieve progress on N&amp;V in the European railway system a number of new technologies and methods should be introduced. This comprises novel technologies for auralisation and visualisation of noise scenarios and development of sound quality criteria as well as different type of new material and adaptive or active technologies and innovative methods.</p> <p>It is also foreseen to propose improvement of innovative mitigation measures that are not directly linked to railway system but could be very efficient for residents protection and for reducing weight and cost for noise control on rolling stock and infrastructure.</p> <ul style="list-style-type: none"> <li>• Auralisation <ul style="list-style-type: none"> <li>○ Use auralisation and visualisation studio for demonstrating different source control alternatives for a number of N&amp;V scenarios of the SPDs</li> </ul> </li> <li>• Sound quality and annoyance studies for the N&amp;V scenarios <ul style="list-style-type: none"> <li>○ Interior comfort: improve sound quality based on new acoustic indicators. This task will use the results of task WA5.2.4 which will produce a panel of representative acoustic interior ambiances.</li> <li>○ Annoyance – Define most effective indicators to represent railways neighbours’ annoyance. For this task, different track and traffic conditions should be taken into account based on the scenarios proposed in task WA5.2.2. Results for exterior noise simulation from task WA5.2.3 and auralisation technique from task WA5.2.7 will be used to investigate annoyance indicators based on listening tests.</li> </ul> </li> <li>• Improvement of a widespread mitigation measure: feasibility of active and other new noise control technology on noise proof windows <ul style="list-style-type: none"> <li>○ Noise proof windows are a widespread abatement measure used for protecting neighbourhood to railway noise. However, this solution is not well accepted by the people and caused more and more opposition as they require living and sleeping with open windows. The idea is to combine sound proof windows with active noise control technology to improve their acceptance by allowing noise and effective mitigation also by an opened window.</li> <li>○ Feasibility of new materials as micro-perforated panel to be implemented to reduce transmission for noise proof windows.</li> </ul> </li> <li>• Other new methods or technologies! <ul style="list-style-type: none"> <li>○ Application of novel materials for increased transmission loss of partitions</li> </ul> </li> </ul>

Figure 130: WA5.2 Gantt chart

WA5.2- Noise and Vibration		2016				2017				2018				2019				2020				2021 - 2024			
Task	Description	Q1	Q2	Q3	Q4	Q1	Q2	Q3	Q4	Q1	Q2	Q3	Q4	Q1	Q2	Q3	Q4	Q1	Q2	Q3	Q4	Q1	Q2	Q3	Q4
WA5.2.1	Technical assessment and integration on system level																								
WA5.2.2	Evaluation of impact on traffic noise scenarios																								
WA5.2.3	Exterior noise simulation model and separation																								
WA5.2.4	Interior noise simulation model																								
WA5.2.5	Ground Borne Vibration Prediction Methods																								
WA5.2.6	Sources and sub-assemblies characterisation methods																								
WA5.2.7	New methodologies and technologies																								

The estimated total budget for WA 5 is around 11.7 M€.





## 6.5.6. Work Area 6 – Human Capital

### Concept and objectives

The overall objective of this Work Area is to bridge the gap between the massive changes in the railway and other industrial sectors imposed by rapid technological advances and the substantial demographic change in the “Human Capital” expected in the near future. In particular, it will study the effects of digitisation and demographic change on the workforce.

The result of WA6 will be a concept on the management of these changes on the human capital side (e.g. change in job profiles, skills, and organisation) of the sociotechnical railway system, imposed by the massive introduction of technical innovations. Furthermore, WA6 will result in recommendations for system design that place the human rather than technology at the centre of the design process (“human-centred design”, “design thinking”). An optimal match between human needs and system design will culminate in safer, healthier and more attractive workplaces for the whole workforce (i.e. white and blue collar workers).

Digitisation and automation of work processes are advancing at high speeds, and will cause radical and disruptive changes in work processes and in their supporting organisations in the near future. At the same time, an aging workforce poses a great challenge to successful operations in most industries and countries. Over the last decade, Europe has experienced a one percent decline in population. Moreover, in the next 15 years, Germany, Italy, and Spain are expected to experience population declines ranging from 14 to 25 percent, according to the United Nations Population Division (Forbes, 2015). This will have a major impact on organisations. Workforce planning will be subject to close scrutiny with respect to increased diversity (e.g. age, gender, ethnicity), flexibility and the technology-driven need for the (life-long) development of new skills in the workforce.

There is a need to quickly find ways to address the challenges that arise from these massive changes in both, technology and human capital. Hence, several research topics in the area of human capital have been identified as of paramount interest for the success and pertinence of results of the Shift2Rail initiative.

### Impact

The work area “Human Capital” will achieve a number of benefits and overcome the challenges imposed by demographic change and comprehensive and radical technological innovations through:

- Increasing flexibility for both, employer and (blue collar) employees
- Making use of the benefits of digitisation and automation for job profiles and skills

This will be supported by new forms of collaboration as well as the design of change architectures for the introduction of comprehensive and radical technical innovations.



### Linkage and alignments with Master Plan

Table 77 shows the links between WA6 and the objectives of the Shift2Rail Master Plan

**Table 77: WA6 links to Master Plan objectives**

Master Plan objectives		Addressed by:
Improved services and customer quality	MP1 Improved reliability	All activities within the WA “Human Capital” support the goal toward “improved reliability” (MP1) even under uncertainty or extreme conditions. Enhanced performance of the operators will also lead towards the goal “Enhancing capacity” (MP2) and “Customer experience” (MP3).
	MP2 Enhancing capacity	
	MP3 Customer experience	
Reduced system costs	MP4 Lower investments costs	The performance of the rail system depends as much upon humans as machines. Operational behaviour depends on organised, reliable, well-trained and professional people who enable the efficient operation of the system. This also contributes to the goals of “reduced operating costs” (MP5) and “Externalities” (MP6)
	MP5 Reduced operating costs	
	MP6 Externalities	

### Relevant EU projects, national projects and past experience

The EU FP7 projects FUTURAIL and SKILLRAIL contributed to increase the knowledge on human capital in the railway sector. As far as possible, the results obtained and the derived conclusions, especially on the matching between the required skills and the existing training programmes, will be considered when establishing the state-of-the-art.

Other WA6 related EU-projects include:

- 2013: CER-ETF Project "Social Aspects and the Protection of Staff in Case of Change of Railway Operator: The Current Situation"
- 2013/2014: CER/ETF Project: Social Dialogue in the Railway Sector in Western Balkan Countries
- 2015: CER / ETF Project: "Promoting employment and quality of work in the European rail sector"
- 2015: CER / ETF Project: "Social conditions in urban public transport"

However, the latest technological developments were not considered in these projects to an adequate extent and will be the focus of the Shift2Rail research.

### Implementation of the work programme

The work area is split into four tasks / research topics.

These tasks respectively aim at assessing:

- The effects of digitisation and automation on the job profiles;



- The change of qualifications and skills due to new technologies and specific training programmes;
- The consequences on employees' flexibility and autonomy of the setting-up of more agile organisations;
- Customer-oriented design of mobility.

For all topics, knowledge transfer from other sectors and benchmarking with industries or sectors that are already highly automated are expected to ensure synergies with regard to skills that are not specific to the railways.

For all tasks, innovative and applicable concepts with a focus on the railway system are expected rather than basic research, focus on other industries or general literature studies <sup>[17]</sup>. However, benchmarking with other industries is expected.

The work plan for WA6 is presented here after in Table 78, and in the Gantt chart.

---

<sup>17</sup> BCG (2015). Man and Machine in Industry 4.0. Forbes (2015)  
<http://www.forbes.com/sites/sap/2015/05/04/the-serious-implications-of-an-aging-workforce/>

**Table 78: WA6 task details**

Task	Task Name	Task Description
WA6.0.1	Change of job profiles	<p>The goal of this task is to elaborate approaches in the realm of jobs, qualification and organisation. This includes methodological approaches, practical experiences, analysis of the “gaps” in qualification and skills, strategies to mitigate potential negative effects and to adopt new organisational design approaches with the goal to match changes in technology with changes in job profiles.</p> <p>Taking into account that digitisation and automation will have a strong effect on the railway sector with maybe higher potentials in this regard than in other (already highly automated) industries, we need to be very well prepared to foresee the disruptive impact on our workforce. How do digitisation and automation change occupational skills, tasks, jobs and profiles in the mobility and logistics sector? The effects should be analysed along the value chain of mobility and logistics since tasks that might be obsolete in the future require another (new) task at another point along the value chain. Hence the change of tasks lead to the incorporation of new elements in jobs and consequently new occupational profiles can derive.</p> <p>However, strong transformation of job requirements can be expected through various drivers (adopted from BCG 2015) such as</p> <ul style="list-style-type: none"> <li>• Big-Data</li> <li>• Optimisation and Simulation with intelligent IT-Systems</li> <li>• Robot-Assisted Production and Maintenance</li> <li>• Predictive Maintenance</li> <li>• Self-Driving Vehicles</li> <li>• Smart and integrated Transport and Supply Networks</li> <li>• Machines as Support</li> <li>• Self-Organising Machines</li> <li>• Additive Manufacturing of Complex Parts</li> <li>• Augmented Work, Maintenance and Service</li> </ul> <p>Due to these transformational effects answers to skills and tasks are necessary to retrain employees and to develop strategic approaches to recruiting and workforce planning as well as to promote job creations.</p> <p>Those answers depend on technical developments and business models. However, an early anticipation of future needs will lead to meaningful short- and medium-term actions e.g. in the purchasing of all kinds of mobile and immobile facilities, installations and IT as well as in the hiring and development process of employees that will result in strong long-term impact.</p> <p>Hence, a comprehensive and distinct methodological approach on how to assess skills and tasks of important jobs in the mobility and logistics sector with regard to relevance and quantity is of high interest as well as the identification of new skills and tasks. Furthermore, practical experiences should be gained in the impact of the above mentioned drivers in order to extrapolate these findings and to enrich a methodological approach with practical movements in the direction of digitisation and automation.</p> <p>Consequently, a better understanding of change and future helps companies to decrease uncertainty, disruption and to develop a transformation path with an emphasis on chances rather than risks which will give a clear perspective to the employees and employee representatives.</p> <p>This task will be an <b>open call</b>: In order to carry out these research topics with</p>

Task	Task Name	Task Description
		<p>different point of views, we will need to associate competences in organisational sciences, human resources and management sciences, safety sciences, demography, sociology, ergonomics, cognitive psychology and economy. Furthermore, in these fields, both qualitative and quantitative skills will be necessary. Indeed, multidisciplinary staffs will have to be constituted.</p> <p>Associated competences required:</p> <ul style="list-style-type: none"> <li>• Proven knowledge of the railway system</li> <li>• Proven knowledge of job profiles in the railway system</li> <li>• Good knowledge of technical developments in the area mentioned above (e.g. Big Data, Optimisation and Simulation with intelligent IT-Systems, robot-assisted production and maintenance etc.) and the effects of such developments on human operator performance and job profiles in general as well as in other highly-automated industries or sectors</li> <li>• Excellent command of the English language and capability to work with an international team</li> <li>• Excellent documentation skills</li> <li>• Excellent oral and written presentation skills</li> </ul>
WA6.0.2	Qualifications and skills	<p>The goal of this task is to take into account the effects of highly automated or robotic systems on operator skills through system design and training initiatives. The requirements for qualification and skills will change dramatically with the introduction of technical innovations. Yet, we do not understand what the effects of new technologies and automated or robotic systems on the performance and skills of the system operators will be and how the requirements for qualification in the mobility and logistics sector will change with respect to the change of operational profiles and tasks. To shed light on these issues, we propose the following:</p> <ul style="list-style-type: none"> <li>• Analysis of the “gaps” between the current and future skill and performance requirements and potential skill degradation</li> <li>• Development of strategies to mitigate potential negative effects on operator skills and to assure the appropriate skills for the job</li> <li>• Training (vocational &amp; recurrent)</li> <li>• Crew resource management: How will new technologies affect the interaction between operators (e.g. the interaction between train drivers and train controllers when the train driver uses a decision support tool that advises him/her of optimal speeds/breaking points, timetabling and maintenance schedule planning etc.)?</li> <li>• Personnel selection: How will the introduction of new technologies affect the selection of personnel?</li> <li>• System design: User-centred design, adaptive automation</li> </ul> <p>A dedicated work area will focus on consequences of specific training programmes which will change culture as well as qualification and skills. Railway companies in Europe have launched various initiatives to foster internal safety awareness and compliance. Two examples can particularly be singled out. One of them is a CRM programme (inspired from air safety Crew Resource Management systems) focused on interpersonal communication, decision making, and situational awareness amongst other dimensions. Another one is a training programme named PRISME, whereby all managers are trained to take into account organisational and human factors in their actions, especially so in transformation plans. In a transformation context with high economics stakes, the effects produced by these programmes, and other conducted</p>

Task	Task Name	Task Description
		<p>simultaneously, are under close scrutiny.</p> <p>In the next few years, the long-term consequences of this type of training programmes on effective safety practices will be studied. This will be a challenge, considering our particularly unstable organisational, market and regulatory context, and the diversity of the existing training initiatives.</p> <p>This task will be an <b>open call</b>: In order to carry out these research topics with different points of views, we will need to associate competences in organisational sciences, human resources and management sciences, safety sciences, demography, sociology, ergonomics, cognitive psychology and economy. Furthermore, in these fields, both qualitative and quantitative skills will be necessary. Indeed, multidisciplinary staffs will have to be constituted.</p> <p>Associated competences required:</p> <ul style="list-style-type: none"> <li>• Proven knowledge of the railway system</li> <li>• Excellent knowledge of Human Factors and experience with human-centred design</li> <li>• Good knowledge of technical developments and the effects of such developments on human operator performance in general, in the railways and in other highly-automated industries</li> <li>• Excellent command of the English language and capability to work with an international team</li> <li>• Excellent documentation skills</li> <li>• Excellent oral and written presentation skills</li> </ul>
WA6.0.3	Creating agile organisations for increased flexibility and autonomy for blue collar workers	<p>The goal of this task is to make use of new technology for increased flexibility, temporal and spatial, of employees and teams with a focus on blue collar workers.</p> <p>Our internal capacity to learn and grow from these training programmes will be all the more critical as the human factor paradoxically is less taken into account today in current transformational patterns in large organisations such as SNCF and DB.</p> <p>This is the foundation for the topic we will address: How to build agile and adaptable organisations that focus on teams rather than individuals? What should be their distinctive features? And how can obstacles to this evolution to be overcome?</p> <p>Other major evolution to take into account is the trend to an individualisation of work, whose consequences are far-reaching. On the one hand, new systems of management are based on an individual rather than a collective evaluation of performance. In some activities, they lead to competition between operators. On the other hand, in the context of organisational changes, the collective dimension of work is rarely taken into account. For corporate decision makers, work teams or collective work are scarcely considered, the first criteria to take into account when reshuffling work organisations. As a result, setting up collective regulations can become very difficult, and work collectives are stirred up, thus experiencing a decrease in performance and / or health deterioration.</p> <p>As previously mentioned, work collectives are an integral part of an organisation's resources to deal with the unexpected. Procedures and automatism cannot be the unique solution to deal with hazardous events. Firstly because anticipations and barriers will never be all-encompassing, and secondly because the accelerations of the sociotechnical environment intrinsically increases any procedure's obsolescence.</p> <p>Fortunately, new organisational design approaches are developing, which place</p>

Task	Task Name	Task Description
		<p>work collectives and collective work practices at their core. Supported by human-adapted IT solutions and nomad devices, they tend to improve organisational adaptation capacities. The « makers movement » (Lallement, 2015) and new collaborative spaces show us how innovative and powerful these organisations can be where they are supported by indigenous regulation.</p> <p>A dedicated work area will focus on flexibility, both in temporal (e.g. shift schedules) and spatial (e.g. remote operation of robotic systems) terms for blue collar workers. A creative approach is needed to use the advantages of technical innovations for employees working in operational and customer-oriented functions to full capacity.</p> <p>Technical innovations will allow for increasingly more work on short-term demand rather than work on long-term schedules. With intelligent predictive maintenance systems, for example, maintenance work, will increasingly shift from a schedule-based system to an on-demand or condition-based system. This will require a more flexible assignment of employees to tasks in the future, sometimes even on short notice. At the same time, there is the trend and preference in the workforce for more flexibility in working conditions. While a lot of research regarding increased flexibility in working conditions has been done for white-collar workers there is little experience with blue-collar workers, especially in the railway sector. Hence, it is an important research topic to study how we can increase job flexibility in the railway sector (e.g. consideration of employee preferences in shift allocation, part-time work, options for telecommuting etc.) for employees working in operational and customer-centred functions (blue-collar workers). We need to find ways in which the need for short-term work assignments can be harmonised with the employees' desire for more flexibility without neglecting the fact that the employees also need planning reliability with respect to their work assignments.</p> <p>This task will be an <b>open call</b>: In order to carry out these research topics with different points of views, we will need to associate competences in organisational sciences, human resources and management sciences, safety sciences, demography, sociology, ergonomics, cognitive psychology and economy. Furthermore, in these fields, both qualitative and quantitative skills will be necessary. Indeed, multidisciplinary staffs will have to be constituted.</p> <p>Associated competences required:</p> <ul style="list-style-type: none"> <li>• Proven knowledge of the railway system</li> <li>• Proven knowledge and application of the principles of high-reliability organisations</li> <li>• Proven knowledge of flexible work concepts for blue collar workers in the railways and other industries</li> <li>• Proven knowledge and application of the principles of autonomous team work</li> <li>• Proven knowledge of organisational development</li> <li>• Excellent command of the English language and capability to work with an international team</li> <li>• Excellent documentation skills</li> <li>• Excellent oral and written presentation skills</li> </ul>

Task	Task Name	Task Description
WA6.0.4	Customer-oriented design of mobility	<p><u>Challenge:</u> Due to its complexity the use of the railway system can pose a big challenge to many passengers. For over 20% of potential passengers, facing the complexity is the single most important reason not to choose the train when choosing the mode of transportation. Passengers need information e.g. about the next bus stop, alternatives in case of disruption, ticketing information, planning information, ticket-price-optimisation, railway station access, platform information, interchange information, preparation for different weather conditions, waiting and information possibilities during the journey, ..., and how they can manage mobility at the destination. In comparison with the use of an own car, this appears substantially more complex and complicated. From a customer's perspective, the travel chain is not designed with respect to usability. The challenge will be the simplification of specific aspects of the railway system and the whole journey from door to door.</p> <p><u>Scope:</u> Successful systems and services are mostly linked to simple solutions, which mean that you can use a device or service without reading an instruction manual (e.g. iphone). These systems and services are based on usability design, keeping things as simple as possible for the user.</p> <p>The task will be to analyse the complexity of each step of the passenger during a journey from door to door. For each critical/ complex activity it will be compared with other customer systems (automotive, flight, internet services, etc.), how it could be modified, deleted or combined with other activities. Hence, proposals should address the simplification of the journey.</p> <p><u>Expected impact</u> Increase the attractiveness of the railway system by a customer-oriented design. It will define specific possibilities to improve the usability and in general will provide an overview of the most critical factors not to use a train from a customer perspective. The perfect result would be achieved if digitisation, automation and technical evolution in combination with the customer focus decrease the number of necessary customer activities and increase the physical and psychological comfort.</p> <p>This task will be an open call.</p> <p>In order to realise these research topics with different points of views, we will need to associate competences in analytical sciences, human resources and usability design, sociology, ergonomics, cognitive psychology and economy. Furthermore, in these fields, both qualitative and quantitative skills will be necessary. Indeed, multidisciplinary teams will have to be constituted.</p> <p>Associated competences required:</p> <ul style="list-style-type: none"> <li>• Proven knowledge of the railway system, its current and future/potential customers and their requirements</li> <li>• Proven knowledge of technological developments in general and applicable to the railway system and its customers</li> <li>• Excellent command of the English language and capability to work with an international team</li> <li>• Excellent documentation skills</li> <li>• Excellent oral and written presentation skills</li> </ul>



**Figure 131: WA6 Gantt chart**

WA6- Human Capital		2016				2017				2018				2019				2020				2021 - 2024			
Task	Description	Q1	Q2	Q3	Q4	Q1	Q2	Q3	Q4	Q1	Q2	Q3	Q4	Q1	Q2	Q3	Q4	Q1	Q2	Q3	Q4	Q1	Q2	Q3	Q4
WA6.0.1	Job profiles																								
WA6.0.2	Qualification and skills																								
WA6.0.3	Flexibility & agile organisations																								
WA6.0.4	Customer-oriented design of mobility																								

The estimated total budget for WA6 is around 0,48 M€.