



**Annex V:
9th Call for Proposals (CFP09) -
List and Full Description of Topics**

Call Text

R1 [V3]

- 30 October 2018 -

Revision History Table		
Version n°	Issue Date	Reason for change
R1 (V1)	18/09/2018	Preliminary draft released for information via JU website and submitted for GB adoption
R1 (V2)	18/10/2018	Updated version released for GB adoption
R1 (V3)	30/10/2018	Final version approved by GB and released for the Participant Portal [Call Launch]



Important notice on Q&As

Question and Answers will open as from the Call Opening date i.e. on or soon after 31 October 2018 via the Participant Portal of the European Commission.

In case of questions on the Call (either administrative or technical), applicants are invited to contact the JU using the **dedicated Call functional mailbox**: Info-Call-CFP-2018-02@cleansky.eu.

Note that questions received **up until 05/12/2018, 17:00 (Brussels Time)** will be answered after analysis and published in Q&A when appropriate. In total, three publications of Q/As are foreseen: 06/11/2018, 22/11/2018 and 19/12/2018 (estimated dates).

The Q/As will be made available via the Participant Portal of the European Commission.

CfP09 Main Information Day

- Info Day Brussels, 8 November 2018

More Information available on the Call and events on the Clean Sky 2 website: www.cleansky.eu



INDEX

PART A: Call topics launched within the complementary framework of IADP/ITD/TA..... 9

1.	Overview of number of topics and total indicative funding value per SPD	9
2.	Call Rules	9
3.	Programme Scene setter/Objectives	10
4.	Clean Sky 2 – Large Passenger Aircraft IAPD.....	13
5.	Clean Sky 2 – Fast Rotorcraft IADP	161
6.	Clean Sky 2 – Airframe ITD	185
7.	Clean Sky 2 – Engines ITD	256
8.	Clean Sky 2 – Systems ITD	280
9.	Clean Sky 2 – Technology Evaluator	326

PART B: Thematic Topics338

1.	Overview of Thematic Topics	338
2.	Call Rules	338
3.	Programme Scene setter/Objectives	339
4.	Clean Sky 2 – Thematic Topics	341

List of Topics for Calls for Proposals (CFP09) – Part A

Identification Code	Title	Type of Action	Value (Funding Action in M€)	Topic Leader
JTI-CS2-2018-CfP09-LPA-01-58	BLI configurations of classical tube and wing aircraft architecture - Wind tunnel tests insight into propulsor inlet distortion and power saving	RIA	3.50	Safran Tech
JTI-CS2-2018-CfP09-LPA-01-59	Fan inlet advanced distortion simulator	IA	2.20	Safran
JTI-CS2-2018-CfP09-LPA-01-60	Innovative low noise fan stator technologies for 2030+ powerplants	RIA	2.50	Safran
JTI-CS2-2018-CfP09-LPA-01-61	Fatigue life prediction on Inco 718 part subject to service induced damages	IA	0.65	GKN Aerospace Sweden
JTI-CS2-2018-CfP09-LPA-01-62	Rear End Structural Test Program – Component & Subcomponent tests	IA	1.10	Airbus
JTI-CS2-2018-CfP09-LPA-01-63	Rear End Aerodynamic and Aeroelastic Studies	RIA	1.25	Airbus
JTI-CS2-2018-CfP09-LPA-01-64	Rear End Structural Test Program - Low level tests	IA	0.70	Airbus
JTI-CS2-2018-CfP09-LPA-01-65	Development of System pipework and Tooling for Sub-Assembly, Final-Assembly of the HLFC-wing Prototype	IA	0.70	Aernnova
JTI-CS2-2018-CfP09-LPA-01-66	Shielding/High-lift composite thermoplastic flap manufacturing, tool design and manufacturing & process definition	IA	0.90	SONACA
JTI-CS2-2018-CfP09-LPA-01-67	UHBR Installed Advanced Nacelle Optimisation and Evaluation Close Coupled to Wing	RIA	3.40	Rolls-Royce
JTI-CS2-2018-CfP09-LPA-01-68	Non-Intrusive Flow Field Measurement within a UHBR Intake	RIA	2.25	Rolls-Royce
JTI-CS2-2018-CfP09-LPA-01-69	Insulation Monitoring for IT Grounded (Isolation Terra) Aerospace Electrical Systems	IA	0.70	Rolls-Royce
JTI-CS2-2018-CfP09-LPA-01-70	Assessment of arc tracking hazards in high voltage aerospace systems	IA	0.75	Rolls-Royce
JTI-CS2-2018-CfP09-LPA-01-71	Innovative Nacelle cowl opening system	IA	0.70	Airbus
JTI-CS2-2018-CFP09-LPA-02-27	Innovative mould for thermoplastic skin of the lower fuselage demonstrator	IA	0.95	NLR
JTI-CS2-2018-CFP09-LPA-02-28	Innovative tooling, end-effector development and industrialisation for welding of thermoplastic components	IA	1.05	Fokker
JTI-CS2-2018-CFP09-LPA-02-29	High performance gas expansion system for halon-free cargo hold fire suppression system.	IA	0.70	Airbus
JTI-CS2-2018-CFP09-LPA-03-16	Automated data collection and semi-supervised processing framework for deep learning	IA	0.80	Honeywell

Identification Code	Title	Type of Action	Value (Funding in M€)	Topic Leader
JTI-CS2-2018-CFP09-LPA-03-17	Audio Communication Manager for Disruptive Cockpit demonstrator	IA	0.70	Airbus
JTI-CS2-2018-CFP09-LPA-03-18	Safe emergency trajectory generator	IA	1.00	Thales Avionics
JTI-CS2-2018-CFP09-LPA: 20 topics			26.50	
JTI-CS2-2018-CFP09-FRC-01-25	Smart Active Inceptors System definition for Tilt Rotor application	RIA	1.25	Leonardo Helicopters
JTI-CS2-2018-CFP09-FRC-01-26	Design, manufacture and deliver a high performance, low cost, low weight Nacelle Structure for Next Generation TiltRotor (NGCTR) - Technology Demonstrator (TD)	IA	5.20	Leonardo Helicopters
JTI-CS2-2018-CFP09-FRC-01-27	Tilt Rotor Whirl Flutter experimental investigation and assessment	RIA	5.00	Leonardo Helicopters
JTI-CS2-2018-CFP09-FRC: 3 topics			11.45	
JTI-CS2-2018-CFP09-AIR-01-40	Anticontamination Coatings and Cleaning Solutions for Laminar Wings	RIA	2.00	Airbus
JTI-CS2-2018-CFP09-AIR-02-68	Spring-in prediction capability for large integral wing structure [SAT]	IA	0.75	Israel Aircraft Industries
JTI-CS2-2018-CFP09-AIR-02-69	Biphasic Heat Transport Integration for Efficient Heat Exchange within Composite materials Nacelle	RIA	0.80	Airbus Defence & Space
JTI-CS2-2018-CFP09-AIR-02-70	Development and application of an innovative methodology devoted for high temperature characterization of high efficient composite structures	RIA	0.70	Airbus Defence & Space
JTI-CS2-2018-CFP09-AIR-02-71	Model Manufacturing and Wind Tunnel Testing of High Lift System for SAT Aircraft [SAT]	RIA	0.80	Piaggio Aero
JTI-CS2-2018-CFP09-AIR-02-72	MEMS sensors, wireless and innovative measurement systems for validation of HVDC system Structure integration and for new SHMS architectures	IA	0.60	Airbus Defence & Space
JTI-CS2-2018-CFP09-AIR-02-73	Material modelling platform for generation of thermoplastic material allowable	RIA	1.25	Airbus
JTI-CS2-2018-CFP09-AIR-02-74	Development of a multipurpose test rig and validation of an innovative rotorcraft vertical tail	IA	0.70	Fokker Aerostructure
JTI-CS2-2018-CFP09-AIR-02-75	Design Against Distortion: Part distortion prediction, design for minimized distortion, additive manufactured polymer aerospace parts	RIA	0.75	Airbus
JTI-CS2-2018-CFP09-AIR-02-76	Cost analysis software platform for evaluating innovative manufacturing technology for SMART fuselage	RIA	0.40	Imperial College London
JTI-CS2-2018-CFP09-AIR-03-06	Calibrating Ultrasonic Sensors for atmospheric corrosion.	RIA	1.50	Dassault Aviation

Identification Code	Title	Type of Action	Value (Funding in M€)	Topic Leader
JTI-CS2-2018-CFP09-AIR: 11 topics			10.25	
JTI-CS2-2018-CfP09-ENG-01-39	Measurement of rotor vibration using tip-timing for high speed booster and evaluation of associated uncertainties	RIA	0.50	Safran Aero Boosters
JTI-CS2-2018-CfP09-ENG-01-40	Turbulence modeling of heat exchangers and roughness impact	RIA	0.60	Safran Aero Boosters
JTI-CS2-2018-CfP09-ENG-01-41	Ground vortex characterization method applicable for engine testing	RIA	0.75	Safran Aircraft Engines
JTI-CS2-2018-CfP09-ENG-01-42	Additive manufacturing boundary limits assessment for Eco Design process optimization [ECO]	RIA	1.50	Safran
JTI-CS2-2018-CFP09-ENG: 4 topics			3.35	
JTI-CS2-2018-CfP09-SYS-01-11	Machine learning to detect Cyber intrusion and anomalies	IA	0.50	Thales
JTI-CS2-2018-CfP09-SYS-01-12	Software engine for multi-criteria decision support in civil aircraft flight management	IA	0.60	Thales
JTI-CS2-2018-CfP09-SYS-01-13	Camera-based smart sensing system for cabin readiness	IA	0.85	Zodiac Engineering
JTI-CS2-2018-CfP09-SYS-01-14	Multi-Material Thermoplastic high pressure Nitrogen Tanks for Aircrafts	IA	0.65	Diehl Aviation
JTI-CS2-2018-CfP09-SYS-02-56	Additive Manufacturing Magnetic Motor	IA	0.70	Safran
JTI-CS2-2018-CfP09-SYS-02-57	Complex cores for CFRP primary structural products manufactured with high pressure RTM	IA	0.50	Fokker
JTI-CS2-2018-CfP09-SYS-03-19	Flexible and Automated Manufacturing of wound components for high reliability	RIA	1.10	University of Nottingham
JTI-CS2-2018-CfP09-SYS-03-20	Demonstration and test of low-loss, high reliability, high speed, bearing-relief generators	RIA	0.80	University of Nottingham
JTI-CS2-2018-CfP09-SYS-03-21	Aircraft wing architecture optimal assembly	RIA	0.50	United Technologies Research Centre
JTI-CS2-2018-CfP09-SYS-03-22	Virtual Testing Based Certification	IA	0.50	dSPACE
JTI-CS2-2018-CFP09-SYS: 10 topics			6.70	
JTI-CS2-2018-CfP09-TE-01-07	Alternative energy sources and novel propulsion technologies	CSA	0.35	DLR
JTI-CS2-2018-CfP09-TE-01-08	Overall Air Transport System Vehicle Scenarios	CSA	0.30	DLR
JTI-CS2-2018-CfP09-TE-01-09	Environmental regulations and policies	CSA	0.20	DLR
JTI-CS2-2018-CfP09-TE: 3 topics			0.85	



List of Topics for Calls for Proposals (CFP09) – Part B

Identification Code	Title	Type of Action	Value (Funding in M€)
JTI-CS2-2018-CFP09-THT-03	Conceptual Design of a 19 passenger Commuter Aircraft with near zero emissions	RIA	0.75
JTI-CS2-2018-CFP09-THT-04	Aircraft Design Optimisation providing optimum performance towards limiting aviation's contribution towards Global Warming	RIA	0.75
JTI-CS2-2018-CFP09-THT-05	Advanced High Bypass Ratio Low-Speed Composite Fan Design and Validation	RIA	2.00
JTI-CS2-2018-CFP09-THT-06	Research for the development of Particulate Matter (PM) regulations and guidelines	RIA	1.00

PART A: Call topics launched within the complementary framework of IADP/ITD/TA

1. Overview of number of topics and total indicative funding value per SPD

SPD Area	No. of topics	Ind. topic Funding (M€)
IADP Large Passenger Aircraft	20	26.50
IADP Regional Aircraft	0	0
IADP Fast Rotorcraft	3	11.45
ITD Airframe	11	10.25
ITD Engines	4	3.35
ITD Systems	10	6.70
Small Air Transport (SAT) related topics*	[2]	[1.55]
ECO Design related topics	[1]	[1.50]
Technology Evaluator	3	0.85
TOTAL	51	59.10
*TA related topics are proposed and embedded in the following SPD and as follows: AIR ITD: 2 SAT topics, 1.55 M€; ENG ITD: 1 ECO topic, 1.50 M€		

2. Call Rules

Before submitting any proposals to the topics proposed in the Clean Sky 2 Call for Proposals, all applicants shall refer to the applicable rules as presented in the “*Second amended Work Plan 2018-2019*” and the “*Rules for submission, evaluation, selection, award and review procedures of Calls for Proposals*”¹.

The following additional conditions apply to the calls for proposals launched within the complementary framework of one IADP/ITD/TA:

1. In the light of the specific structure of the programme and the governance framework of the JU, the specific legal status and statutory entitlements of the “members” of the JU and in order to prevent any conflict of interest and to ensure a competitive, transparent and fair process, the following “additional conditions” in accordance with Article 9.5 of the H2020 Rules for Participation:

¹ These documents are accessible via the Participant Portal.

² See the definition under Article 2.1(2) of the H2020 Rules for Participation
CS-GB-Writ proc 2018-08 Annex V CFP09 Second Amended WP and Budget 2018-2019 – R1 [V3]



- **The 16 Leaders of JU listed in Annex II to Regulation n° (EU) No 558/2014 and their affiliates²** may apply to Calls for Proposals **only in another IADP/ITD** where they are not involved as Members.
 - **The Core partners and their affiliates** may apply to calls for proposals only in another IADP/ITD where they are not involved as member.
2. Applicants may apply to calls for proposals if they:
- officially state whether they are an affiliate³ to a member of the JU or not;
 - Issue a declaration of absence of conflicts of interest⁴.
- These elements shall determine the admissibility of the proposal.

The above criteria and the declarations will be checked by the JU which will determine the admissibility of the proposals. The CS2JU reserves its right to request any supporting document and additional information at any stage of the process.

Please note that proposals may include the commitment from the European Aviation Safety Agency (EASA) to assist or to participate in the action without EASA being eligible for funding.

Please note that the provisions under the chapters on “Special skills, Capabilities, Certification expected from the Applicant(s)” do not constitute additional conditions for participation according to Art. 9(5) H2020 Rules for Participation.

3. Programme Scene setter/Objectives

In accordance with Article 2 of the COUNCIL REGULATION (EU) No 558/2014 of 6 May 2014⁵ the **Clean Sky 2 high-level (environmental) objectives are:**

“(b) to contribute to improving the environmental impact of aeronautical technologies, including those relating to small aviation, as well as to developing a strong and globally competitive aeronautical industry and supply chain in Europe.

This can be realised through speeding up the development of cleaner air transport technologies for earliest possible deployment, and in particular the integration, demonstration and validation of technologies capable of:

- (i) increasing aircraft fuel efficiency, thus reducing CO₂ emissions by 20 to 30 % compared to ‘state-of-the-art’ aircraft entering into service as from 2014;*
- (ii) reducing aircraft NO_x and noise emissions by 20 to 30 % compared to ‘state-of-the-art’ aircraft entering into service as from 2014.”*

These Programme's high-level (environmental) objectives have been translated into **targeted vehicle performance levels**, see table below. Each conceptual aircraft summarises the key

² See the definition under Article 2.1(2) of the H2020 Rules for Participation

³ See the definition under Article 2.1(2) of the H2020 Rules for Participation

⁴ As part of the declaration, the legally authorized representative of the applicants entities will be requested to declare whether the representative(s) of the entity participate to the IADP/ITD steering committees and whether they representative(s) of the entity was involved in the preparation, definition and approval of the topics of the calls or had any privileged access information related to that.

⁵ JOL_2014_169_R_0006

enabling technologies, including engines, developed in Clean Sky 2.

Conceptual aircraft / air transport type	Reference a/c*	Window ¹	ΔCO_2	ΔNO_x	Δ Noise	Target ² TRL @ CS2 close
Advanced Long-range (LR)	LR 2014 ref	2030	20%	20%	20%	4
Ultra advanced LR	LR 2014 ref	2035+	30%	30%	30%	3
Advanced Short/Medium-range (SMR)	SMR 2014 ref	2030	20%	20%	20%	5
Ultra-advanced SMR	SMR 2014 ref	2035+	30%	30%	30%	4
Innovative Turboprop [TP], 130 pax	2014 130 pax ref	2035+	19 to 25%	19 to 25%	20 to 30%	4
Advanced TP, 90 pax	2014 TP ref ⁴	2025+	35 to 40%	> 50%	60 to 70%	5
Regional Multimission TP, 70 pax	2014 Multi-mission	2025+	20 to 30%	20 to 30%	20 to 30%	6
19-pax Commuter	2014 19 pax a/c	2025	20%	20%	20%	4-5
Low Sweep Business Jet	2014 SoA Business a/c	2035	> 30%	> 30%	> 30%	\geq 4
Compound helicopter ³	TEM 2020 ref (CS1)	2030	20%	20%	20%	6
Next-Generation Tiltrotor	AW139	2025	50%	14%	30%	5

*The reference aircraft will be further specified and confirmed through the Technology Evaluator assessment work.

1 All key enabling technologies at TRL 6 with a potential entry into service five years later.

2 Key enabling technologies at major system level. The target TRL indicates the level of maturity and the level of challenge in maturing towards potential uptake into marketable innovations.

3 Assessment v. comparable passenger journey, not a/c mission.

4 ATR 72 airplane, latest SOA Regional A/C in-service in 2014 (technological standard of years 2000), scaled to 90 Pax.

To integrate, demonstrate and validate the most promising technologies capable of contributing to the CS2 high-level and programme specific objectives, the CS2 technology and demonstration activity is structured in **key (technology) themes**, further subdivided in a number of **demonstration areas**, as depicted below. A demonstration area may contribute to one or more objectives and also may involve more than one ITD/IADP.

Ref-Code	Theme	Demonstration area
1A	Breakthroughs in Propulsion Efficiency (incl. Propulsion-Airframe Integration)	Advanced Engine/Airframe Architectures
1B		Ultra-high Bypass and High Propulsive Efficiency Geared Turbofans
1C		Hybrid Electric Propulsion
1D		Boundary Layer Ingestion
1E		Small Aircraft, Regional and Business Aviation Turboprop
2A	Advances in Wings, Aerodynamics and Flight Dynamics	Advanced Laminar Flow Technologies
2B		Regional Aircraft Wing Optimization
3A	Innovative Structural / Functional Design - and Production System	Advanced Manufacturing
3B		Cabin & Fuselage
3C		Innovative Solutions for Business Jets
4A	Next Generation Cockpit Systems and Aircraft Operations	Cockpit & Avionics
4B		Advanced MRO
5A	Novel Aircraft Configurations and Capabilities	Next-Generation Civil Tiltrotor
5B		RACER Compound Helicopter
6A	Aircraft Non-Propulsive Energy and Control Systems	Electrical Systems
6B		Landing Systems
6C		Non-Propulsive Energy Optimization for Large Aircraft
7A	Optimal Cabin and Passenger Environment	Environmental Control System
7B		Innovative Cabin Passenger/Payload Systems
8A	Eco-Design	
9A	Enabling Technologies	
	Technology Evaluator	



The individual topic descriptions provide more detailed information about the link/contribution to the high-level objectives.

4. Clean Sky 2 – Large Passenger Aircraft IAPD

I. JTI-CS2-2018-CfP09-LPA-01-58: BLI configurations of classical tube and wing aircraft architecture - Wind tunnel tests insight into propulsor inlet distortion and power saving

Type of action (RIA/IA/CSA):		RIA	
Programme Area:		LPA	
(CS2 JTP 2015) WP Ref.:		WP 1.1.3.6	
Indicative Funding Topic Value (in k€):		3500	
Topic Leader:	Safran Tech	Type of Agreement:	Implementation Agreement
Duration of the action (in Months):	36	Indicative Start Date (at the earliest)⁶:	Q3 2019

Topic Identification Code	Title
JTI-CS2-2018-CfP09-LPA-01-58	BLI configurations of classical tube and wing aircraft architecture - Wind tunnel tests insight into propulsor inlet distortion and power saving
Short description	
Boundary Layer Ingestion aircraft configurations aim to reduce the propulsive system power consumption, but face the challenge of the propulsive fan ingesting a distorted flow. This project will focus on the BLI configurations of tube and wing aircraft architectures. Through wind tunnel tests, it should allow a better understanding of the dependencies of the fan inlet distortion pattern and power saving, on the aircraft as well as the propulsor main geometric characteristics and operating points. The knowledges will serve for the “DX2 Boundary Layer Ingestion” demonstrator.	

Links to the Clean Sky 2 Programme High-level Objectives ⁷				
This topic is located in the demonstration area:		Boundary Layer Ingestion		
The outcome of the project will mainly contribute to the following conceptual aircraft/air transport type as presented in the scene setter:		Ultra-advanced Long-range Ultra-advanced Short/Medium-range		
With expected impacts related to the Programme high-level objectives:				
Reducing CO₂ emissions	Reducing NO_x emissions	Reducing Noise emissions	Improving EU Competitiveness	Improving Mobility
<input checked="" type="checkbox"/>	<input type="checkbox"/>	<input type="checkbox"/>	<input type="checkbox"/>	<input type="checkbox"/>

⁶ The start date corresponds to actual start date with all legal documents in place.

⁷ For further info see Chapter 1 “Introduction to the Programme Scene Setter / Objectives” with key technology themes / demonstration areas. Detailed information available in the CS2 Development Plan accessible via the Clean Sky JU Website and EC Participant Portal.

1. Background

One objective of future propulsion systems is to provide a fuel burn reduction. Boundary Layer Ingestion is expected to improve the aeropropulsive efficiency and could be an enabling technology to achieve this goal. The recent wind tunnel tests tend to confirm this tendency, and highlight that the fan ingesting the boundary layer works under a major distortion.

Several aircraft architectures have been identified with a propulsive system integration allowing BLI. For mid-term perspectives, the more realistic configurations are based on an adaptation of the conventional tube and wing aircraft architecture. The adaptations studied in the literature follow two main paths: the first one with buried engines ingesting a part of the fuselage boundary layer (BLI 180°, ex: Figure 3). The propulsor inlet distortion is not axisymmetric, with two quadrants under distortion and two under a lower distorted flow or without distortion.

the second one with the complete ingestion of the fuselage boundary layer (BLI 360°), such as a propulsive fuselage configuration (BLI 360°, ex: Figure 1 and Figure 2). The propulsor inlet distortion is mainly axisymmetric, all quadrants are under distortion. The axisymetry of this distortion could be modified depending on the aircraft architecture, and flight attitude.



Figure 1 - Propulsive Fuselage – NASA's STARC-ABL turboelectric Plane Concept (NASA, 2018)



Figure 2 - Aft tail configuration (FP 7 DISPURSAL, 2018)

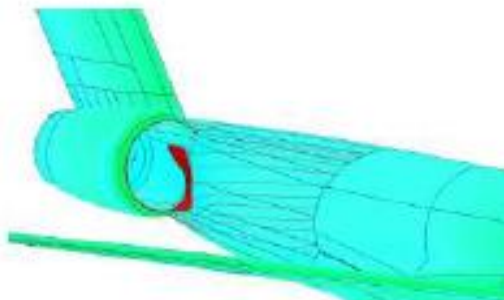

Figure 3 – rear fuselage part with a BLI180° propulsor architecture

State of the Art: In the literature, several wind tunnel tests can be found considering a body of revolution and a ducted fan or unducted propeller (Atinault, et al., 2014; Sabo & Drela, 2015; Lv, Poli, Perpignan, & Rao, 2016). All these test campaigns have been performed at low speed focusing on the measurement of the power consumption and the boundary layer ingested. High speed wind tunnel tests have been conducted on a boundary layer ingesting fan. In this wind tunnel test, the aircraft is not included, and only a BLI 180° distortion pattern is considered (Hirt, et al., 2018).

All the BLI wind tunnel tests past, running or planned, mainly focus on the power saving, the inlet distortion, and the fan behavior ingesting the boundary layer, for a specific aircraft architecture.

To define the best aircraft architecture to integrate the BLI technology, it is important to assess the dependencies of the propulsor inlet distortion and the power saving to this architecture. And yet no wind tunnel campaign has been dedicated to study widely this aspect. The work proposes in this topic will handle this subject and will contribute to the promotion of the BLI technology for a conventional aircraft tube and wing from a TRL1 to a TRL3.

2. Scope of work

The objective of this project is an insight into the distortion in front of the propulsor inlet, the power saving coefficient estimation and the impact on the aircraft aerodynamics, depending on the BLI configuration, the propulsor characteristics, the aircraft configuration and the flight conditions (free stream, and operating conditions).

Aircraft configurations

For the aircraft, a generic SMR A/C with a tube and wing configuration should be considered as a reference. Keeping the tube and wing configuration, variations of geometries is expected such as (but not limited to):

- The positioning of the wings (axial, height),
- The positioning of the tail (aft, merged, in front the nacelle)

The variabilities (components to consider, type and number of variations) actually tested will be defined by the project. They have to be selected to obtain the most versatile wind tunnel tests database.

Relevant reference configurations have to be included in the test program (such as reference configuration without propulsor, propulsor alone).

The specification of the different configurations will be detailed at the beginning of the project, based on a state of the art analysis (scientific bibliography), the background of the applicant, and CFD computations.

Moreover, a major task of the project is the design of the scale models, which have to be highly and quickly reconfigurable to cover all the requested geometric variations.



Propulsor

The applicant will propose the more relevant technology to model the propulsor. In fact, for the project objectives, it is only required to be able to vary the mass flow going through inlet, and the kinetic energy provided by the propulsor model to the flow (to assess the power saving).

For the nacelle geometry, a first guess of variation is the inlet diameter to vary the proportion of a boundary layer and free stream captured. The selection of the appropriate diameters and the others important geometric variations of the propulsor have to be defined during the first phase of the project.

Testing conditions

For the representativity of the final database, it seems more comfortable to ensure during the wind tunnel test a Reynolds number around 5 million with the fuselage length of the scale model as reference, and a fuselage length around 1.5 meters. Nevertheless, slightly smaller scale and Reynolds number could propose if the applicant is able to justify the representativity of the results obtained and its ability to perform accurate measurement of the inlet distortion and other aerodynamic quantities.

To have a representative database, the test conditions should cover the classical SMR A/C flight Mach number from a take-off condition (Mach number around 0.25 - Subsonic) to a cruise condition (Mach number around 0.8 – Transonic), classical attitudes for the angle of attack and angle of sweep, and also variations of the massflow of propulsor from partial massflow to full massflow.

Measurements

To fulfill the objectives, extensive measurements have to be performed. Below a list of the characteristics required to measure:

- Detailed flow characteristics at different stations along the fuselage and upstream of the propulsor, including one as close as possible to the propulsor inlet section.
- Boundary layer characteristics in the chordwise direction along the fuselage.
- Power saving coefficient.
- Depending on the architecture: aerodynamic flow characteristics at the propulsor outlet.
- Performance of the propulsor model (power provided to the flow/power consumed).
- Aircraft loads, aerodynamics.

The specification of the measurements (type, location, quantities) will be detailed at the beginning of the project, based on dedicated CFD computations.

Challenges and Innovations

- Definition of the more relevant aircraft configurations, conditions to be tested.
- Definition of the proper measurements.
- Design of a highly versatile scale models, test bench, and acquisition data systems.
- Post test activities to perform analysis and completion of the wind tunnels results, full scale transposition, and identification of the aircraft architecture key drivers to improve the inlet distortion and the power saving.

Tasks

Task 1 – Specification and Risk analysis

This task covers the definition of the specifications: aircraft configuration and propulsor variabilities, test conditions and measurements. The specifications should be defined based on a state of the art analysis (scientific bibliography), the background of the applicant, and CFD computations. CFD computations will

also be used in the second steps for the test program refinement.

Task 2 – Scale model

This task covers the scale models design and realisation.

Sub-tasks:

- Conceptual Scale Models Design
- Preliminary Scale Models Design
- Detailed Scale Models Design
- Scale Models Manufacturing, Assembly
- Scale Models acceptance and qualification testing

Task 3 – Test bench and Acquisition Data Systems

This task covers the test bench and ADS realisation

Sub-tasks:

- Preliminary Test Bench and ADS Design
- Detailed Test Bench and ADS Design
- Test Bench and ADS Manufacturing, Assembly
- Test Bench and ADS acceptance and qualification testing

Task 4 – Tests

This task covers the integrated test of the models, the wind tunnel test preparation and the wind tunnel test operation.

Sub-tasks:

- Test of the integrated Models and ADS
- Testing preparation
- Wind Tunnel tests

Task 5 – Analysis and ways forward

Sub-tasks:

- Wind tunnel results post-processing (post-processing of the raw results, enhanced and full scale extrapolation of the wind tunnel results using CFD)
- Synthesis and ways forward analysis

Tasks		
Ref. No.	Title - Description	Due Date in months relative to T0
Task_1	Specification and Risk analysis	T0+4
Task_2	Scale models	T0+24
Task_3	Test Bench and ADS	T0+24
Task_4	Wind Tunnel Tests	T0+30
Task_5	Analysis and ways forward	T0+36

3. Major Deliverables/ Milestones and schedule (estimate)

**Type: R=Report, D=Data, HW=Hardware*

The main deliverables of the project are the wind tunnel test data (measurements, free stream conditions, aircraft and propulsor configurations, attitude and operating conditions) and the CAD of the

scale models. The measurement results should be provided as raw data at the end of the tests, and post-processed data integrating wind tunnel corrections, analysis, etc.

Deliverables			
Ref. No.	Title - Description	Type*	Due Date
Del_01	Specification and Risk analysis Review Presentation Specification and Risk analysis Report and CFD results	R & D	T0+4
Del_02	Concept Design Review Presentation Concept Design Report	R	T0+5
Del_03	Preliminary Design Review Presentation Preliminary Design Report	R	T0+7
Del_04	Critical Design Review Presentation Critical Design Report	R	T0+12
Del_05	Manufacturing Review Presentation Manufacturing Report	R	T0+23
Del_06	Component Testing Review Presentation Component Testing Report CAD of the scales models and the test bench	R & D	T0+24
Del_07	Testing Preparation Review Presentation Testing Preparation Report and pre-tests CFD results	R & D	T0+27
Del_08	Wind Tunnel Test Review Presentation Wind Tunnel Test Report - Wind Tunnel Test Raw Data	R & D	T0+30
Del_09	Results Post-Processing Review Presentation Results Post-Processing Report - Final wind tunnel test data	R & D	T0+34
Del_10	Synthesis Review Presentation Synthesis Review Report	R	T0+36

Milestones (when appropriate)			
Ref. No.	Title - Description	Type*	Due Date
MS_1	Specification Review	R	T0+4
MS_2	Scale Models, Test Bench and ADS COR	R	T0+5
MS_3	Scale Models, Test Bench and ADS PDR	R	T0+7
MS_4	Scale Models, Test Bench and ADS CDR	R	T0+12
MS_5	Manufacturing Review	R	T0+23
MS_6	Component Testing Review	R	T0+24
MS_7	Testing Preparation Review	R	T0+27
MS_8	Wind Tunnel Test Review	R	T0+30
MS_9	Final wind tunnel test data delivery Review	R	T0+34
MS_10	Synthesis Review	R	T0+36

4. Special skills, Capabilities, Certification expected from the Applicant(s)

- Wind tunnels allowing low speed and high speed freestream conditions. It seems more comfortable to have facilities allowing a Reynolds number around 5 million with the fuselage length of the scale model as reference, and a fuselage length around 1.5 meters. Slightly smaller scale and Reynolds number could propose if the applicant is able to justify the representativity of the results obtained



and to justify its ability to perform accurate measurement of the inlet distortion and other aerodynamic quantities.

- Wind tunnel tests execution and postprocessing capabilities
- Advanced aerodynamics measurement capabilities and skills
- Advanced skills in Computational Fluid Dynamics
- CFD software with a relevant validation and scientific acknowledgement in the field of aircraft and turbomachinery aerodynamics
- Advanced skills in numerics
- Advanced skills in numerical results analysis
- High-performance computation resources access
- CFD capabilities
- Mechanical design
- Aerodynamic design
- Manufacturing and assembly: provisioning (raw material, components like sensors); machining; controlling of scale models, test bench and sub assembly.
- Testing and inspecting: subcomponent, sensors, ...

5. **Abbreviations**

BLI	Boundary Layer Ingestion
ADS	Acquisition Data Systems
COR	Concept Design Review
PDR	Preliminary Design Review
CDR	Critical Design Review
DR	Drawing Review
SMR A/C	Small Medium Range Aircraft (ie. Airbus A320)
FPR	Fan Pressure Ratio
PIV	Particule Image Velocity
Pt	Total pressure

II. JTI-CS2-2018-CfP09-LPA-01-59: Fan inlet advanced distortion simulator

Type of action (RIA/IA/CSA):		IA	
Programme Area:		LPA	
(CS2 JTP 2015) WP Ref.:		WP 1.1.3.6	
Indicative Funding Topic Value (in k€):		2200	
Topic Leader:	Safran	Type of Agreement:	Implementation Agreement
Duration of the action (in Months):	47	Indicative Start Date (at the earliest)⁸:	Q3 2019

Topic Identification Code	Title
JTI-CS2-2018-CfP09-LPA-01-59	Fan inlet advanced distortion simulator
Short description	
<p>Future aircraft architectures tend to higher level of distortion at the Fan inlet. The project intends first to develop a software aimed at finding out a design of a proper distortion device that would generate a pre-defined distortion map. Then, a second part will be devoted to the software validation, by performing wind tunnel tests (without any engines) onto various configurations to survey the real distortion charts obtained. This process will be first applied on steady distortion patterns and then on unsteady ones.</p>	

Links to the Clean Sky 2 Programme High-level Objectives ⁹				
This topic is located in the demonstration area:		Boundary Layer Ingestion		
The outcome of the project will mainly contribute to the following conceptual aircraft/air transport type as presented in the scene setter:		Advanced Long-range Ultra-advanced Long-range Advanced Short/Medium-range Ultra-advanced Short/Medium-range		
With expected impacts related to the Programme high-level objectives:				
Reducing CO₂ emissions	Reducing NO_x emissions	Reducing Noise emissions	Improving EU Competitiveness	Improving Mobility
<input checked="" type="checkbox"/>	<input type="checkbox"/>	<input type="checkbox"/>	<input type="checkbox"/>	<input type="checkbox"/>

⁸ The start date corresponds to actual start date with all legal documents in place.

⁹ For further info see Chapter 1 "Introduction to the Programme Scene Setter / Objectives" with key technology themes / demonstration areas. Detailed information available in the CS2 Development Plan accessible via the Clean Sky JU Website and EC Participant Portal.

1. Background

The next generation propulsion systems will be based upon Ultra High Bypass Ratio –UHBR- turbofan engines, which have less fuel burn potential but represent also less risks in terms of configuration compared to the Open Rotor propulsion system. The Topic Leader is currently preparing and contributing to this next generation of emerging alternative propulsion systems, targeting the next generation aircraft.

Due to new and severe integration constraints such as short inlets, reduced ground clearances or other airframe alternative installation effects (e.g. Boundary Layer Ingestion –BLI- architectures) future UHBR fans will experience high levels of inlet flow distortion.

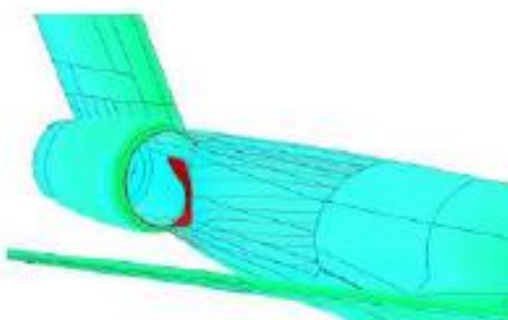

Figure 1 – schematic illustration of highly distorted flow conditions

Within the framework of Clean Sky 2, these architectures and the associated engine installation effects will be deeply explored across both LPA IADP and ENG ITD, leading to gradually increasing TRL rig tests and ground test demonstrators. In particular, the proposed work below can be directly applied to mature the BLI demonstrator named “DX2”, or for specific fan designs that will be rig tested on SA²FIR rig.

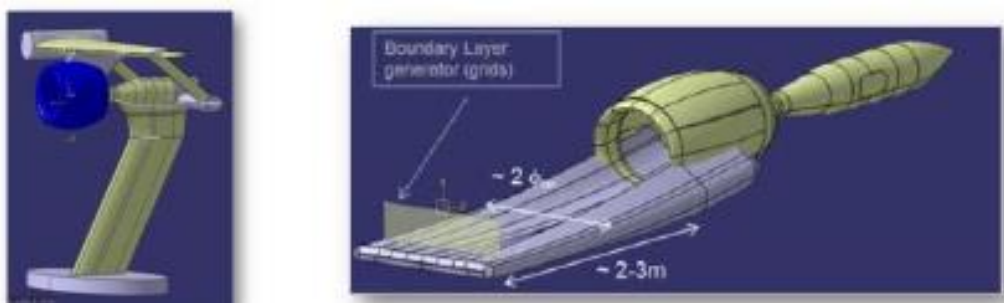

Figure 2 – sketch of SA²FIR rig (left) and application for BLI (right)

The purpose of these studies and related tests will aim to have a better knowledge of the future architectures integrated design concepts, including a better insight of how an optimized fan system can be integrated. For instance, dedicated rig tests will provide a fine mapping of the flow characteristics surrounding the engine inlet and therefore will provide a necessary data bank to mature and calibrate existing numerical methods that are used during the design phase to predict the flow characteristics in the fan inlet plane.

Indeed, from a fan design perspective, the overall UHBR or BLI distortion patterns will differ from conventional and already known patterns by the intensity and the complexity of the distorted flow that will be experienced in the fan inlet plane. We already foresee that these highly distorted inlet flows will increase the detrimental impacts already observed on conventional architectures that can operate with

moderate inlet distorted conditions.

The distortion patterns that will be generated by UHBR short inlets or BLI installations will directly affect the fan performance (flow capacity, adiabatic efficiency, and additional losses in the by-pass duct) and its operability (stall margin penalty, earlier flutter onset, blades increased vibratory stresses under forced response).

Existing process/ risks:

Up to now, the engine/airframe advanced installation effects in the fan design process need to be assessed through a very long process using numerical aerodynamic and mechanical computations, and validated through several growing complexity tests (isolated rig tests, installed rig tests, ground engine demonstrator, and flight demonstrator). The engine installed rig tests have for instance to include a fuselage part, a pylon, wing sections or any relevant part of the aircraft impacting the engine operation, so that the flow characteristics at engine inlet are as representative as they are expected to be on a full engine installation. Finally, the ground tests and flight tests demonstrators are used to validate the perfect appropriateness of the installed engine within the selected aircraft architecture.

The complexity of this process is a drastically limiting factor when it comes to explore different concepts or to perform deep parametric and sensitivity studies for UHBR (especially for fan module). The main risk, if the design space exploration is limited, would be to miss a real global optimum or to orientate our design efforts in a zone where the fan operability or performance may reveal to be poor or inappropriate.

Indeed, in case these distortion effects are not correctly understood, quantified and anticipated during the overall fan and inlet design process, the resulting fan module may not be robust enough to ensure the targeted performance and operability specifications, and therefore will need long and additional rework phases before meeting an acceptable compromise. Moreover, this fan-inlet lack of compatibility may be discovered too late in the development plan (e.g. after having carried out rig tests in an installed configuration, or during installed ground engine tests), which could thus jeopardize the entire engine/airframe certification plan.

Therefore, an alternative and more flexible way to explore rapidly the fan design limits in a given distorted environment has to be imagined. The goal is to get a faster feed-back on the fan performances and operability impacts when operating in an inlet distorted flow, and to iterate more rapidly either on the fan blade design itself or on the inlet design, or to some extent on the nacelle /airframe installation (to mitigate the distortion strength).

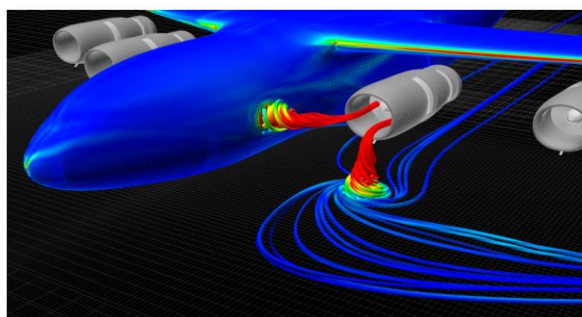

Figure 3 - Ground and fuselage vortices impinging on a turbofan inlet (courtesy “ensight”)

During design analysis based on computations, these crosswind distortions are often assessed as steady. However, test measurements show that flow quantities at fan inlet could fluctuate around an average distortion pattern. This point is in particular illustrated in the figure below where pressure

measurements display steady disturbances according to the engine rotating speed (average pressure) and unsteady behavior (pressure fluctuations). Depending of the configuration, the distortion pattern should thus be considered steady or unsteady.

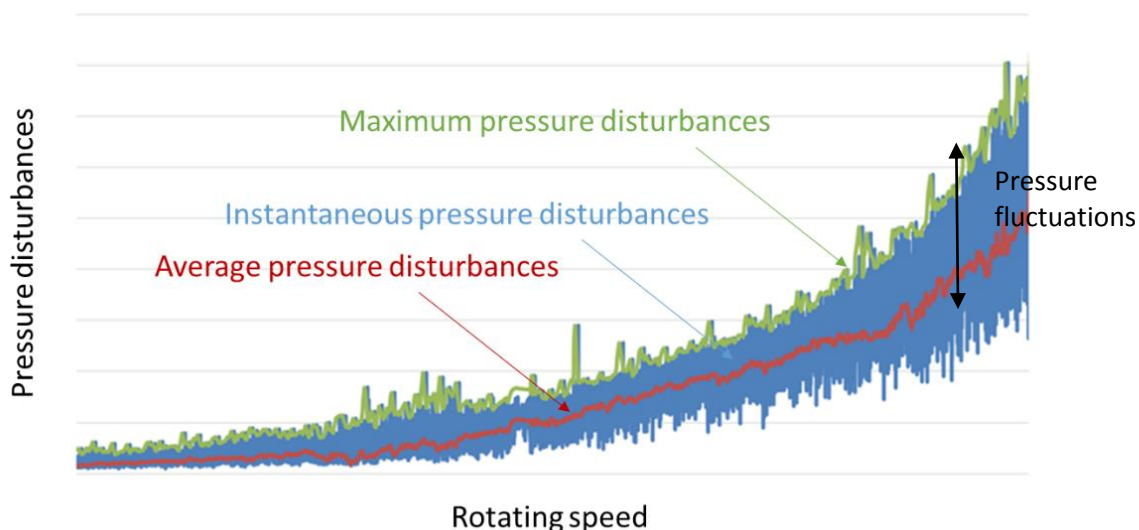

Figure 4 - Pressure disturbance measurement for separated inlet

Fan blade aerodynamic and aeromechanical behaviors in a highly distorted environment are up to now assessed using numerical methodologies that are neither fully calibrated, nor validated for the distortion topologies that will be met in advanced architectures. The first step in the calibration of these methodologies is to assess them by dedicated experiments simulating UHBR or BLI-like distortions. In the existing distortion screens state of the art (SoA), only limited patterns can be generated and in particular, there is neither simple nor accessible device in Europe enabling to generate simultaneously a total pressure deficit, flow swirl and a fluctuating vortex, which is a typical example of topology most likely to be met on BLI architectures.

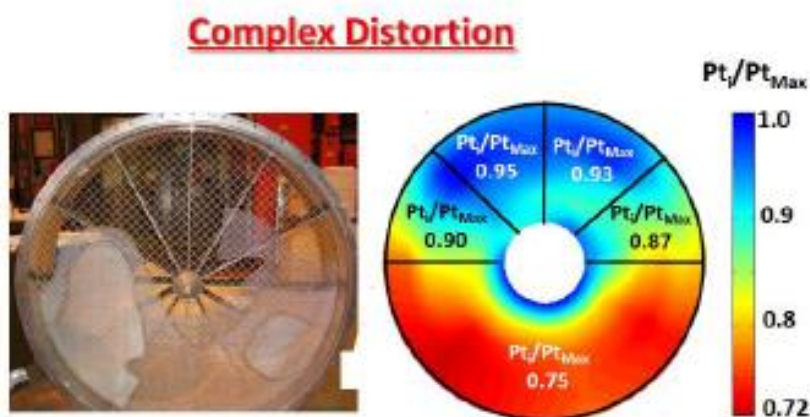

Figure 5 – example of distortion screen (total pressure map)
[GT2011-45068, ASME TurboExpo2011]

2. Scope of work

This study has been split into two distinct work packages (WP) that will be described below:

- Task 1: dealing with steady distortion patterns
- Task 2: focusing on unsteady distortion patterns

Tasks		
Ref. No.	Title - Description	Due Date
T1.1	<u>Tool development – Methodological work</u> Based on a preliminary literature survey, several existing numerical methods enabling to create distortion devices will be identified and analysed. For instance, promising methodologies based on inverse design methods can be benchmarked, then a down selection will be made according to their ability to provide the targeted steady distortion patterns . A preliminary software based on the down selected methodology will then be encoded and tested on 1 or 2 basic distortion patterns (software functional validation)	T0+8
T1.2	<u>Tool development- Preliminary tests & calibration</u> Based on several academic distortion patterns close to BLI-like in terms of intensity and azimuthal/radial range , the numerical tool will be used to generate the corresponding distortion devices. Then, for each case, a direct CFD verification will be performed to check the relevancy of the resulting distorted flow . In case of discrepancies identified between targeted and resulting distortion patterns, the software will be modified or calibrated until the targeted distortion pattern(s) are actually met with a reasonable accuracy	T0+14
T1.3	<u>Tool development- Application work</u> The numerical tool developed in T1.2 will then be used to generate 4 3D-geometries that will generate 4 real distortion patterns including pure or combined steady phenomena, and directly related to CS2 “DX2 BLI demonstrator” or SA ² FIR BLI configuration test campaigns. Again, the resulting distortion patterns will be obtained by CFD (direct method on the distortion simulators 3D-geometries) to check their relevancy vs. expected distortion indices and distorted flow topology. This work will be performed at WT sub-scale	T0+20
T1.4	<u>Tool experimental validation- Manufacturing & tests</u> Based on the 4 distortion simulators CAD definition, define the detailed designs and relevant fabrication tolerances. Perform integration studies to ensure that the distortion device will be correctly integrated in the WT test section environment (static and dynamic structural analysis). Then manufacture these 4 devices for wind tunnel evaluation. Conduct sub-scale testing of the 4 devices and obtain full azimuth pressure and three-component velocity measurements	T0+30
T1.5	<u>Tool experimental validation- Assessment and method update</u> The test results issued by T1.4 will be post-processed and compared to the desired input and CFD predictions. Finally, the test results will be used to update the distortion simulator software.	T0+34

Tasks		
Ref. No.	Title - Description	Due Date
T2.1	<p><u>Methodological work</u></p> <p>Based on a preliminary literature survey, several existing devices enabling to create unsteady distortion patterns with variable location and/or variable intensity fluctuations (amplitude-frequency) will be identified and analysed. Then a down selection will be made according to their ability to provide the targeted unsteady fluctuations. A preliminary device will be defined and numerically-tested on simple unsteady patterns fluctuations to check the relevancy of the obtained fluctuations characteristics.</p> <p>NB: This task can be linked to tasks performed in WP1 (literature survey, combination of WP1 device generating a steady distortion map and fluctuating device to generate required fluctuations)</p>	T0+18
T2.2	<p><u>Application work</u></p> <p>The preliminary PoC developed in T2.1 will then be adjusted to generate 2 real unsteady distortion patterns: (1) fluctuations spatial range (2) fluctuations intensity & frequency, directly related to fluctuations characteristics foreseen on CS2 “DX2 BLI demonstrator” or SA²FIR BLI configuration test campaigns. This work will be performed at WT sub-scale</p>	T0+24
T2.3	<p><u>Experimental validation- Manufacturing & tests</u></p> <p>As far as possible, the WT test rig already used in T1.4 will be used in T2.3. Based on the 2 unsteady distortion simulators identified in T2.2, define the detailed designs and relevant fabrication tolerances. Perform integration studies to ensure that the distortion devices will be correctly integrated in the WT test section environment (static and dynamic structural analysis). Then manufacture these 2 devices for wind tunnel evaluation. Conduct sub-scale testing of the 2 devices and obtain full azimuth pressure and three-component velocity measurements as function of time, with an appropriate sampling rate.</p>	T0+34
T2.4	<p><u>Experimental validation- Assessment and method update</u></p> <p>The test results issued by T2.3 will be post-processed and compared to the desired input and CFD unsteady predictions. Finally, the test results will be used to update the PoC design rules.</p>	T0+41

Task 1

As specified here above, all this study relies on steady distortion patterns.

Tool development

The first objective of this project is to develop and validate a tool (software and associated methodology) enabling to define a distortion device that will generate a pre-defined steady distortion map with high-fidelity.

Typically, this distortion map is the one experienced inside a turbofan air-inlet, upstream the fan blades, and under particular flight conditions. The distorted flow can be characterized by classical indexes (IDC, IDR, K^2 , SI) that enable to have a first quantitative approach of the intensity, the radial and azimuthal range, as well as the nature of the impacted physical quantity (total pressure, static pressure, velocity angles). Some examples of distortion patterns are illustrated in the figures below:

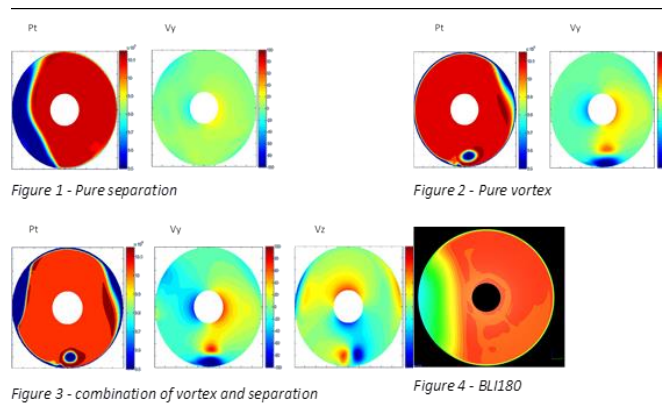

The distortion device should therefore be able to generate - under steady consideration - either patterns related to one peculiar phenomenon (local flow separation, one or more vortices, flow swirl) or the combination of several phenomena. In particular, the methodology and the related software developed will be able to carry out parametric studies aiming at simulating different patterns:

- BLI like with various installations (more or less buried)
- Vortex with variable location and/or swirl intensity
- combination of a vortex and a typical flow pattern met during X-wind operation (mainly total pressure).

For instance, in the frame work of DX2 BLI demonstrator, SAFRAN AIRCRAFT ENGINES is interested in studying different BLI topologies, without excluding inlet separation phenomena or/and vortex effects, making location vary from tip to hub or having its intensity more or less amplified as shown in the figures below:

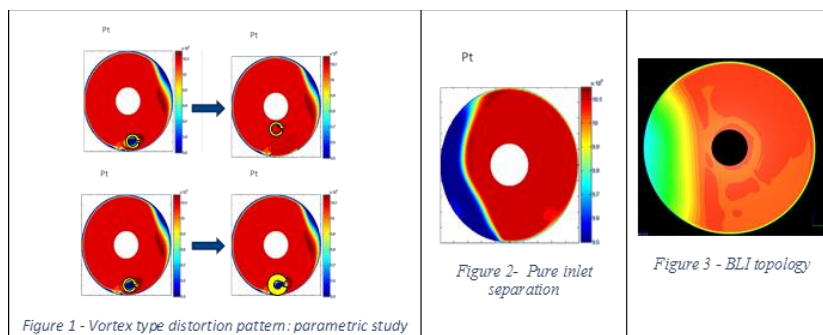

Based on a preliminary literature survey, several existing numerical methods enabling to create distortion devices will be identified and analysed. For instance, promising methodologies based on inverse design methods can be benchmarked, then a down selection will be made according to their ability to provide the targeted steady distortion patterns. A preliminary software based on the down selected methodology will then be encoded and tested on several academic distortion patterns.

The demonstration will consist in creating one or several distortion devices (mixing either screens or vanes or vortex generators...) and to check by a direct CFD analysis that the targeted distortion pattern(s) are actually met with a reasonable accuracy.

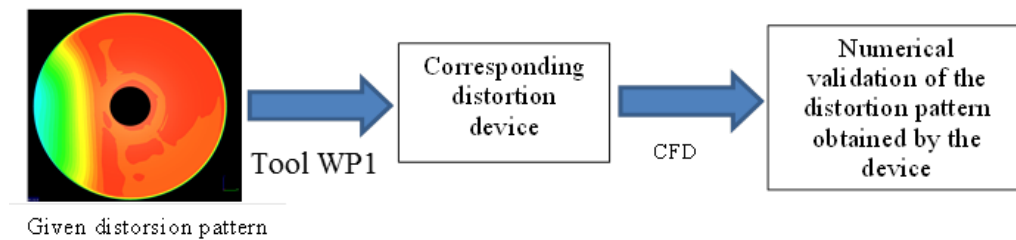

Tool experimental validation:

A second part will be devoted to the software validation, by performing wind tunnel (WT) tests (without any engine or fan module parts) onto 4 configurations to characterize the real distortion maps obtained. Again, this process will be applied on steady distortion patterns.

The 4 distortion grids designed thanks to the tool developed in the first part will be manufactured (reduced scale) using a simple process, e.g. additive manufacturing (3D printing) in order to evaluate the obtained distortion profile in an appropriate wind tunnel. A rather plain material (plastic or thermoplastic) will be used during this manufacturing step.

The selected wind tunnel facility will be able to test 5 to 10'' diameter distortion devices in a range of Mach number representative of fan inlet absolute Mach number (0.0-0.7), in accordance with the flight case on which the distortion is modeled.

The swirl/distortion profile evaluation in wind tunnel will give access to following values: Radial and Tangential Flow Angles, Total and Static Pressures, 3D Velocity Components (u,v,w), 2D Swirl Profile (In-Plane Velocity Magnitude). The use of an automated probe traverse (radial movement) that can give as well access to full azimuth pressure and three-component velocity measurements is recommended.

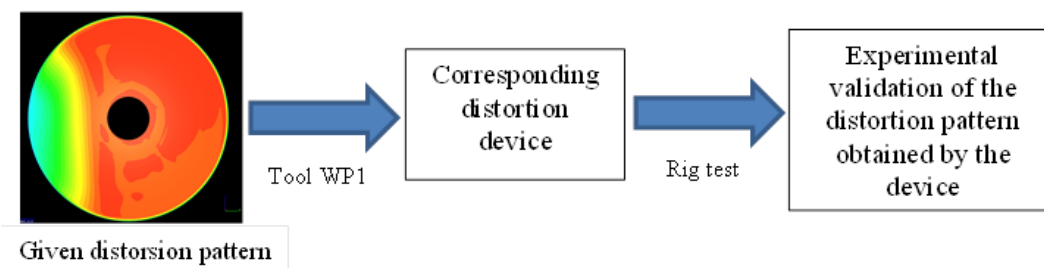

Task 2

In addition of WP1 studies based on steady distortion patterns, this second part will only focus on a POC (proof of concept) as regards unsteady distortion patterns.

PoC development

This part aims at developing a technology and a design tool (software and associated methodology) that will permit to define an unsteady distortion device from a pre-defined steady distortion map from WP1. The distortion device should be able to generate intensity and location variations of the pre-defined steady distortion map from WP1 at various frequency. This device should allow to perform parametric studies in order to characterize and evaluate the impact of unsteadiness of a given distortion pattern on the fan behavior. For instance, in the frame work of DX2 BLI demonstrator, SAFRAN AIRCRAFT ENGINES is interested in studying the impact of distortion unsteadiness on fan operability and aeromechanical response.

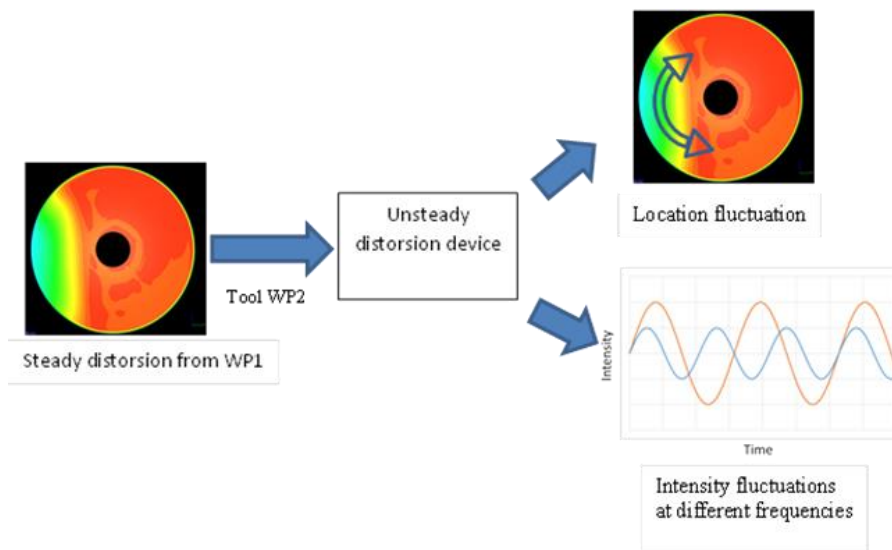

Based on a preliminary literature survey, unsteady distortion devices will be identified and analysed. A preliminary PoC will be proposed and designed. The demonstration will consist in creating location and intensity distortion fluctuations and to check by a direct CFD analysis of the PoC design that the targeted disturbances are actually met with a reasonable accuracy.

PoC experimental validation:

A second part will be devoted to validate the unsteady distortion device in a rig test. The PoC will be manufactured (reduced scale) using a simple process, e.g. additive manufacturing (3D printing) in order to evaluate the obtained distortion fluctuation profile in an appropriate wind tunnel. A rather plain material (plastic or thermoplastic) will be used during this manufacturing step. The test facility will be the same than the wind tunnel (WT) used in the WP 1. The selected wind tunnel facility will be able to test 5 to 10" diameter distortion devices in a range of Mach number representative of fan inlet absolute Mach number (0.0-0.7), in accordance with the flight case on which the distortion is modeled.

Steady and unsteady measurements will give access to following values: Total and Static Pressures, 3D Velocity Components (u,v,w), 2D Swirl Profile (In-Plane Velocity Magnitude). The use of an automated probe traverse (radial movement) that can give as well access to full azimuth pressure and three-component velocity measurements is recommended.

3. Major Deliverables/ Milestones and schedule (estimate)

*Type: R=Report, D=Data, SW=Software

The main deliverables of the project are the 3D geometry of the PoC design and the associated wind tunnel tests data (unsteady measurements). The measurements data should be provided as raw at the end of the tests, and post-processed integrating wind tunnel corrections.

Deliverables			
Ref. No.	Title - Description	Type*	Due Date
D1.1	Preliminary software demonstrator - A preliminary software version will be issued, including a documentation (user & developer)	SW +R	T0+8

Deliverables			
Ref. No.	Title - Description	Type*	Due Date
D1.2	Updated software demonstrator - Distortion simulator calibrated on academic cases: a new software version will be released, including a documentation (user & developer)	SW +R	T0+14
D1.3	3D geometries – (CAD files) corresponding to the 4 real distortion patterns will be released, including the final CFD check report	D+ R	T0+20
D1.4	Wind Tunnel Tests report – Will compile all experimental data acquired during the WT tests, and environment information useful to perform a rig-scale assessment (T1.5)	D +R	T0+31
D1.5	Final software- this final version will integrate all lessons learned and design rules issued from T1.5, including an updated documentation (user & developer)	SW +R	T0+34
D2.1	3D geometries – (CAD files) corresponding to the 2 real unsteady distortion patterns will be released, including the final CFD check report	D+R	T0+24
D2.2	Wind Tunnel Tests report – Will compile all experimental data acquired during the WT tests, and environment information useful to perform a rig-scale assessment (T2.4)	D+R	T0+35
D2.3	Final report- this report will summarize the work performed in T2.1 to T2.3, and will integrate all lessons learned during design and testing phases. Design rules issued from T2.4, including an updated documentation (user & developer) will be included in this report.	R	T0+41

Milestones (when appropriate)			
Ref. No.	Title - Description	Type*	Due Date
M1.1	Methodology Review- Validation of methodology down selection based on existing know-how and bibliography survey	R	T0+5
M1.2	Update software review	SW +R	T0+14
M1.3	Test Distortion devices Critical Design Review (CDR)	D + R	T0+20
M1.4	WT Tests Readiness Review (TRR)	R	T0+26
M1.5	WT Post Tests Review and final software validation	R +D+ SW	T0+34
M2.1	Methodology Review- Validation of methodology down selection based on existing know-how and bibliography survey	R	T0+12
M2.2	Test Distortion devices Critical Design Review (CDR)	D + R	T0+24
M2.3	WT Tests Readiness Review (TRR)	R	T0+35
M2.4	WT Post Tests Review and final conclusions	R +D+ SW	T0+41



4. Special skills, Capabilities, Certification expected from the Applicant(s)

- Software development,
- Advanced aerodynamics skills,
- Mechanical design: static; dynamic,
- Turbomachinery,
- Advanced aerodynamics measurement capabilities and skills,
- Wind tunnel tests facilities representative in Mach and Reynolds numbers requirement,
- Wind tunnel tests execution and postprocessing capabilities,
- Manufacturing and assembly: provisioning (raw material, components like sensors); machining; controlling of scale models, test bench and sub assembly,
- Testing and inspecting: subcomponent, sensors

5. Abbreviations

BLI	Boundary Layer Ingestion
ADS	Acquisition Data Systems
COR	Concept Design Review
PDR	Preliminary Design Review
CDR	Critical Design Review
UHBR	Ultra High Bypass Ratio
CFD	Computational Fluid Dynamic
POC	Proof Of Concept
WT	Wind Tunnel

III. JTI-CS2-2018-CfP09-LPA-01-60: Innovative low noise fan stator technologies for 2030+ powerplants

Type of action (RIA/IA/CSA):		RIA	
Programme Area:		LPA	
(CS2 JTP 2015) WP Ref.:		WP 1.1.3.6	
Indicative Funding Topic Value (in k€):		2500	
Topic Leader:	Safran	Type of Agreement:	Implementation Agreement
Duration of the action (in Months):	48	Indicative Start Date (at the earliest)¹⁰:	Q3 2019

Topic Identification Code	Title
JTI-CS2-2018-CfP09-LPA-01-60	Innovative low noise fan stator technologies for 2030+ powerplants
Short description	
<p>Low noise fan stator solutions are key technological components for Future Generation UHBR to ensure continuous aircraft noise reduction while addressing low Fuel Burn and associated CO2 targets. The objective is to mature innovative approaches such as passive flow control OGV design as well as soft (treated) stator options to overcome challenging UHBR fan module specificities (reduced rotor – stator spacing, reduced OGV count). Efficient stator concepts are to be designed. Experimental validation of most promising solutions will be performed on a large scale aero and acoustic fan rig while exploring in parallel new manufacturing processes to address engine integration constraints. The maturation of the solutions will be focussed on UHBR application, but results could have benefits on BLI or Open Rotor powerplant systems.</p>	

Links to the Clean Sky 2 Programme High-level Objectives ¹¹				
This topic is located in the demonstration area:		Ultra-high Bypass and High Propulsive Efficiency Geared Turbofans		
The outcome of the project will mainly contribute to the following conceptual aircraft/air transport type as presented in the scene setter:		Ultra-advanced Long-range Ultra-advanced Short/Medium-range		
With expected impacts related to the Programme high-level objectives:				
Reducing CO ₂ emissions	Reducing NO _x emissions	Reducing Noise emissions	Improving EU Competitiveness	Improving Mobility
<input type="checkbox"/>	<input type="checkbox"/>	<input checked="" type="checkbox"/>	<input type="checkbox"/>	<input type="checkbox"/>

¹⁰ The start date corresponds to actual start date with all legal documents in place.

¹¹ For further info see Chapter 1 “Introduction to the Programme Scene Setter / Objectives” with key technology themes / demonstration areas. Detailed information available in the CS2 Development Plan accessible via the Clean Sky JU Website and EC Participant Portal.

1. Background

The desire for more ecologic and more economic turbofan engines in civil aviation leads to an increase in the “ByPass Ratios” (BPR) and lower “Fan Pressure Ratios” (FPR). The next generation of engines with significantly higher Bypass Ratios (UHBR) are being developed to further reduce the fuel consumption. These engines have a larger fan diameter, a lower rotation speed and a reduced number of blades. Drag and weight penalties induced by the increased engine diameter are typically being offset by means of shorter and thinner nacelles and extensive use of composite materials. These architecture evolutions are having several consequences on the engine noise signatures. Fan noise becomes even more the predominant acoustic source of the engine and its signature tends to shift towards low frequencies.

Advanced UHBR engines architecture should furthermore includes fan module specificities like reduced rotor – stator spacing and reduced OGV count. Such fan module architecture evolutions are pivotal to rich higher UHBR engine performance efficiency but in other hand imply noise drawbacks on fan/OGV interaction tone and broadband noise.

Innovative approach to design low noise OGV are in consequence foreseen to overcome challenging UHBR fan module specificities and achieve both performance and noise objectives.

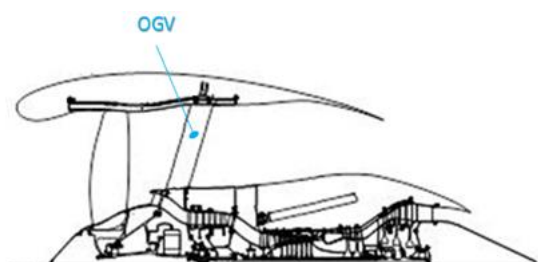

Figure 1 : Typical outlet guide vanes in UHBR engine environment



Figure 2 : Outlet guide vanes stator stage (~40 OGVs) in actual engine environment

Even improved considerations regarding aeroacoustic OGV blade design guidelines (like lean and swept) are expected to be no more enough efficient to offset sufficiently fan/OGV interaction noise increase associated to such more aggressive UHBR fan module evolutions.

Consequently, advanced low noise OGV concepts are now required to further reduce fan/OGV interaction noise sources. Innovative approaches such as passive flow control OGV design as well as soft (treated) stator options, have recently been studied in the frame of EU programmes. These programmes have shown promising results and perspectives to reduce the rotor-stator noise interaction by controlling the OGV acoustic response.

Further maturation studies are required to reach good prospects for their application in future UHBR engines.

Room exists to further develop and propose advanced passive flow control and soft stator low noise OGVs concepts. More efficient wavy leading edge OGVs can be developed using advanced aeroacoustics design tools and new findings in the field from previous research programmes. Innovative soft stator solutions (including improved acoustic material and/or dissipative technology components) can be optimised to maximise the acoustic dumping and to reduce the OGV acoustic response. Such wavy and treated OGV have to be produced with dedicated manufacturing process. Additive manufacturing technics could be for example suggested to produce advantageously the innovative OGVs concepts.

Furthermore, a combination of the solutions will bring the opportunity to reduce more effectively

interaction noise sources and to go beyond the current state-of-the-art.



Figure 3 : Serrated OGV 3D prototypes



Figure 4 : Soft vane prototype



Figure 5 : Soft solutions extension along the OGV side

Such efficient low noise OGVs could become a key technology to investigate more aggressive fan stage design space with reduced fan/OGV spacing (previously limited by noise constraints), which will further improve the overall propulsive efficiency of futur UHBR turbofan engines. This could also become a highly valuable technology to further improve the noise margin and/or fuel efficiency for 2030+ advance architectures, like unducted Open Rotor with Stator or BLI. Therefore, low noise OGV solutions have to be considered as part of the UHBR technologies that will help fulfill CS2 environmental and performance objectives. Indeed a noise reduction up to 2 EPNdB cumulative at aircraft level is expected relative to UHBR 2030+ Next engine generation without low noise OGV solutions.

The subject of this topic concerns the development of low noise OGV able to withstand UHBR engine integration and specifications. The activities include acoustic (and also aerodynamic) TRL4 demonstration on a UHBR large scale fan rig test to assess the potential of innovative low noise OGV concepts under representative working conditions.

This activity is part of the “Ultra-high Bypass and High Propulsive Efficiency Geared Turbofans” demonstration area and the UHBR Integration roadmap. Results will feed into the UHBR engine model for use in the Technology Evaluator to assess the noise benefit. Two different full scale demonstrator OGVs will be produced to showcase the advancedments in manufacturing capabilities.

2. Scope of work

The main concern is to develop innovative low noise OGVs. Advanced OGV solutions allowing to reach targeted noise performance while satisfying high aerodynamic efficiency and good mechanical properties prospects have to be designed for UHBR engine application.

To reduce rotor-stator interaction noise sources, there is a need to change the fan wake strength and/or the stator acoustic response. Unless otherwise stated, it is assumed that here that the innovative low noise OGVs will become or be derivate from at least one of the following concepts:

- (1) Aeroacoustics vane design with specific leading edge concepts, such as serrations, undulations or separation
- (2) Passive soft leading edge including dedicated material like porous or micro channel eventually connected to appropriate cavity chambers or resonators
- (3) Active soft leading edge including dedicated components allowing it to optimize and control aeroacoustics damping properties

To achieve more efficient low noise OGV solution, a combination of several noise reduction concepts (even if these have not been identified above, like FP7 OPENAIR treated OGV) may be beneficial as far as

promising integration perspective (in particular aerodynamic and mechanic) can be reasonably achieve. A gradual stage maturation approach will be pursued to mature the new low noise OGV technology with improve acoustic performance. Firstly, at least five different vane prototypes will need to be designed, manufactured and tested to demonstrate acoustic performance on appropriate TRL2/3 experimental set-up able to mimic broadband and tones interaction noise mechanisms. Following these outcomes, three new low noise full 3D stator stage will be produced and tested on a TRL4 UHBR large scale fan rig demonstrator. Acoustic and aerodynamic pperformance will be furthermore assessed thanks to a back to back test matrix including comparison with two other available state of the art stator stage.

In parallel, high fidelity modelisation will be investigated to better predict aeroacoustics performance and allow design optimization. Broadband and tones Interaction noise in presence of each low noise source reduction concepts have to be at first simulated based on dedicated reduce models. Then a whole simulations of the tested UHBR large scale configurations including low noise stator stage will be pursued.

All along the project, the applicant will have to study full scale integration aspects in order to further increase the technology readiness level and prospects for future aircraft engine application. Full scale low noise OGV demonstrators will be developed and manufactured for at least two different family concept. Compliance with specification will have to be validated through partial mechanical test.

Advanced Low noise OGV maturation work plan is typically spread 4 years in order to achieve TRL4 demonstration. The main tasks are developed below:

Tasks		
Ref. No.	Title – Description	Due Date
Task 1	Innovative low noise stator - Risk reduction plan (M1.1, D1.1)	T0+39 m
Task 2	Innovative low noise stator – Requirements (D2.1, D2.2)	T0+15 m
Task 3	Innovative low noise stator - Concepts review & screening (M3.1, M3.2, ,D3.1)	T0+39 m
Task 4	Innovative low noise stator - OGV prototypes detailed design for concept selection of test bench demo (M4.1, D4.1)	T0 +15 m
Task 5	Innovative low noise stator - OGV prototypes manufacturing for concept selection of test bench demo (D5.1)	T0 +18 m
Task 6	Innovative low noise stator - OGV prototypes of test bench demonstration and performance analysis (M6.1,M6.2, D6.1)	T0 +24 m
Task 7	Innovative low noise stator - Advance modelling and simulations (M7.1, D7.1)	T0 +48 m
Task 8	Innovative low noise stator - Stator prototypes detailed design for large scale demo (M8.1, D8.1)	T0+36 m
Task 9	Innovative low noise stator - Stator prototypes manufacturing for large scale demo (D9.1)	T0+42 m
Task 10	Innovative low noise stator – Stator performance evaluation and analysis on large scale demo (M10.1, D10.1)	T0+45 m
Task 11	Innovative low noise stator - Smart components and technologies integration demonstrator (M11.1, M11.2, M11.3, M11.4, D11.1, D11.2)	T0+48 m

Preliminary high level (targeted) requirements for tests bench demonstrations:

- TRL2/3 test bench aeroacoustic demonstration (Task 6)
 - OGV dimension (scale): ~ up to 250 mm (~1/3).

- Grid-turbulence from open-jet wind tunnel test section ~ 0.75 m dia. ; And/Or
- Representative fan module rig ; And/Or equivalent wake generator dispositive; Mach number : ≥ 0.3 (targeted 0.6); Anechoic environment
- Acoustic characterisation (wall sensors, near and far field instrumentations, ...)
- Aerodynamic characterisation (hot wire/5 holes probes, balance...)
- TRL4 large scale fan aeroacoustic demonstration (Task 10)
 - Module fan dimension (scale): ~ 700mm dia.(~1/3).
 - Scaled Rotor speed : ~ up to 10 000 Rpm
 - Static test rig ; Anechoic environment
 - Acoustic characterisation (wall sensors, in duct modal detection, near and far field instrumentations, ...)
 - Aerodynamic characterisation and fan module performance
- TRL3 integration demonstrator (Task 11)
 - OGV dimension (scale) : ~ up to 0.7 m (1/1)
 - Partial test rig for mechanical assessments (static, dynamic, impacts,...)

The following table indicates the OGVs parts that will have to be develop and manufacture for the corresponding tests bench demonstrations:

Test bench demonstrations type	OGVs quantities to develop and manufacture	Number of configuration to test
TRL2/3 test bench aeroacoustic demonstration	1 prototype per configuration (5)	7 OGVs configurations = 5 low noise concepts + 2 references (*) (task 6)
TRL4 large scale fan aeroacoustic demonstration	1 low noise full stator stage of ~ 40 OGVs per configuration (3)	5 stator stage module configurations = 3 low noise concepts + 2 references (*) (task 10)
TRL3 integration demonstrator	1 prototype per configuration (2)	3 OGVs configurations = 2 low noise concepts + 1 reference (*) (task 11)

(*) Reference parts will be provided by topic manager

The applicant has to ensure management and reporting activities throughout the project. A management plan has to be delivered and partner's progresses regularly reported. The applicant has also to support all project monitoring and coordination tasks.

- Progress Reporting & Reviews:
 - Regular progress reports in writing shall be provided by the partner
 - Regular coordination meetings shall be conducted via telecom.
- General Requirements: The partner shall work to a certified standard process.

Task 1: Innovative low noise stator - Risk reduction plan

To provide and achieve a plan including test and capability demonstration for each technical task and element. The applicant has to establish and deliver the related risk reduction plan. Mitigation actions and status shall be adequately monitored.

Task 2: Innovative low noise stator – Requirements

To contribute to the UHBR low noise OGVs specifications written under Safran Aircraft Engines leadership. The applicant has to support in particular the requirements break down into detailed technical elements to ensure full compliance assessment capacity.

Task 3: Innovative low noise stator - Innovative concepts review & screening

The applicant has to perform a screening of the best Low noise OGV concepts that will include at least the already three known concept family ((1) Aeroacoustic vane design with specific serration or separation leading edge profiles (see fig. 3) ; (2) passive soft leading edge including dedicated material like porous or micro channel eventually connected to appropriate cavity chambers (see fig .4) ; (3) Active soft leading edge including dedicated components to control aeroacoustics damping properties) and associated components allowing them to develop prototypes and to provide a first background analysis / scorecard.

The applicant has to identify technological solutions allowing for further improvement of acoustic properties (improving acoustic response damping and attenuation performance) while satisfying integration requirements (in particular aerodynamic and mechanic). In this perspective, there is a need to explore advanced solutions and technology transfer opportunities, such as generating more efficient geometries with additive manufacturing or increasing damping response proprieties (thanks to an extra control technology device (passive/active system). In this perspective, soft solutions extension along the OGV side (4) (see fig.4 & fig.5) have also to be considered to increase acoustic efficiency.

The screening works shall allow the applicant to select promising OGV prototypes concept and large scale stator prototypes (to be designed respectively in task 4 and task 8). Selections shall be performed considering also compliance with engine integration requirements (aerodynamic efficiency, lightweight, adverse environmental functioning conditions, structural integration prospects...), including for the 3D full scale vane demonstrator to be develop in task 11.

Task 4: Innovative low noise stator - OGV prototypes detailed design for concept selection test bench demo

Considering advanced solutions identified in task 3, the applicant has to design innovative OGV concept prototypes that will be tested in task 6. They have to be compatible with the experimental set-up and facility that will be used to generate broadband and tonal interaction noise on OGV leading edge. The OGV prototypes to be tested in task6 should have as far as possible the same dimensions and scale than the ones targeted for large scale tests in order to reduce uncertainties.

Design objectives and constraints will have to be clearly identified, justified and explained. Models of each low noise OGV concept have to be developed and used to allow to allow for OGV optimization at an early design stage.

The applicant has to considerate at least 5 potential solutions identify in task 3 to develop efficient OGV prototypes. Low noise OGV concepts and associated technologies will be detailed during formal design reviews (Concept selection, CoR, PDR and CDR for OGV prototypes) considering criteria, such as aero-acoustic benefits (tones and broadband noise reduction, wide band frequency performance, aerodynamic efficiency ...) and a good integration for future UHBR turbofan engines. At CDR, applicant has to present detailed design definitions for at least five innovative OGV prototypes (which include improved/derivate/modified solutions from concepts (1), (2), (3) and (4)) in order to manufacture (task 5) for acoustic and aerodynamic test bench demonstration (task 6).

Task 5: Innovative low noise stator - OGV prototypes manufacturing for concept selection test bench demo

To manufacture the 5 innovative OGV concept prototypes complying with the task4 detailed definitions. Applicant has to manufacture at least five OGV concept prototypes that fulfil the specifications from final CDR definition in task4. Furthermore, the selected OGV concept prototypes have to be compatible with the experimental set-up in task6. To this end, applicant has to ensure OGV prototypes maturation (MRL) and make certain the manufacturing skills/process to comply with technical specifications



(innovative shape, specific damping material ...). Additionally, the applicant will be in charge of providing (acquire, built or transform, ...) all components, materials and supplies that are required for the OGV prototype manufacturing. This also implies that the applicant should ensure provide working tests and validation equipment.

Task 6: Innovative low noise stator – OGV prototypes tests bench demonstration and performance analysis

To characterise innovative low noise OGV prototypes acoustic performance in test bench. The acoustics tests will include a comparison with 2 reference OGV. The aerodynamic performance of the different OGV prototypes has to be sufficiently characterised along with the acoustic measurements in order to highlight the interest of the different OGV designs from an aerodynamic perspective

A presentation of the main test results & analysis is expected by the partner. The applicant has to test the five innovative Low noise OGV prototypes delivered by task 5 and compared them with state-of-the-art OGVs.

Appropriate and sufficiently representative experimental tests have to be performed achieve an acoustic TRL2/3 for the tested OGV concepts. The experimental test set-up will offer the opportunity to characterize broadband and tonal noise of OGV concepts with a similar scale to the ones that will be used in the fan rig tests (task10). To this end, an appropriate experimental set-up has to be considerate for broadband interaction noise. This experimental facility could consist of a wind tunnel tests bench with a wake generator (well defined and strong viscous wake targeted) upstream of the OGV prototype in an anechoic chamber. It should be noted that grid-turbulence from an open-jet wind tunnel would be sufficient to assess the broadband interaction noise from different OGV concepts. However, a wake generator is necessary to predict tonal interaction noise. Other relevant test benches or facilities can also be proposed by the applicant to characterize broadband and tonal noise sources from the OGVs.

Each OGV prototype (7 in total) will be characterized at 5 different flow conditions sufficiently representative of the mean flow Mach number perceived by the OGVs along the fan working line.

The test campaign will focus on the acoustic measurements using near-field and/or far-field microphones and advanced source localization method. Additionally, aerodynamic measurements will be performed to well establish aeroacoustics flow conditions (and damping phenomena) and to measure potential side effects on aerodynamic efficiency.(acquiring, the drag and lift forces measured via a torque and axial force balance and steady and/or unsteady wall pressure distributions on the OGV).

Task 7: Innovative low noise stator - Advance modelling and simulations

The aim is to perform high-fidelity numerical simulations of low noise OGV concepts that are able to account for both broadband and tonal noise. Numerical simulations will be performed for at least 3 low noise OGV concepts under representative working conditions.

Firstly, the applicant has to develop or propose a relevant wake-interaction noise simulation/model that is able to account for aerodynamic, acoustic and damping material effects. This advanced modelling will be useful to optimize the aero-acoustic performance of the low noise OGV concepts for the large scale OGV application.

Full 3D numerical models of the low noise stator grid inside large scale module fan environment have to be then established to better understand way to optimise further the low noise stator concepts in 3D. Using this numerical model, applicant will have to compare the acoustic (and aerodynamic) performance of the low noise OGV vs reference (state of the art OGV stator).

Task 8: Innovative low noise stator – Full stator stages detailed design for large scale demo

To perform a detailed design of the 3D large scale low noise complete stator stage complying with the specifications provided by Task 2.



Based on previous task feedback and lessons learned, three 3D full stator stage will be specifically designed for interaction noise reduction purpose. Dedicated aerodynamic shape, absorbing components and structures will be designed to ensure acoustic demonstration on 3D large scale rig tests. As for task4, a gradual design and validation approach will be followed in task8 to ensure a logical progress towards innovative designs adapted for turbomachinery applications. Thus, models of the low noise OGV have to be further developed and validated to allow for a 3D optimization of full OGV designs. Experimental results from preliminary tests in task6 have to be analysed to reinforce 3D modelling accuracy.

The applicant has to considerate three potential solutions identify in task 3 that will be defined during design reviews (component selection, CoR, PDR and CDR for 3D large scale full stator stages). At CDR, applicant has to present detailed design definitions for the three stator stages (of around 700mm diameters each) that will be manufactured (task 9) for large scale demo tests (task 10).

Task 9: Innovative low noise stator – Full stator stages manufacturing for large scale demo

Applicant has to manufacture three low noise stator stages (of around 700 mm diameter each) according to final CDR definitions. Prior to this, the applicant will have to investigate, support, and further develop 3D manufacturing processes for the OGV prototypes as defined in task8. This implies detailed component bricks assessments (specific manufacturing process for aerodynamic shape, surface roughness and/or absorbing materials), preliminary 3D prototypes to prove the concept, and finally the manufacturing of the full OGV stages. The applicant will also be in charge of providing (acquire, built or transform,...) all components and materials required to manufacture the OGVs, as well as related test functioning and validation equipment.

Task 10: Innovative low noise stator – Full stator stages performance evaluation and analysis on large scale demo

To characterise acoustic performance of full low noise stator stages on UHBR large scale fan rig demonstrator. Aerodynamic performance will also have to be characterised to check potential efficiency degradation. The acoustics tests campaigns will also include back-to-back comparisons with other 2 available state-of-the-art reference stator stages (conventional and low count).

The applicant will propose standard and advanced acoustics measurements using near-field/far-field microphones, in-duct modal detection and advanced source localization methods (for instance, beamforming methods ...). Additionally, aerodynamics measurements (pressure/temperature rakes, hot wire measurements ...) are required to fully characterize and understand the stator performance.

Each operating line will be described by around 15 operating points surrounding approach and take off conditions. Applicant has to perform acoustic and aerodynamic data acquisitions on each configurations. Applicant will be also in charge to perform presentation of the test results and analysis.

Task 11: Innovative low noise stator vane - Full scale low noise OGVs demonstrator and integration study

To conduct full scale engine integration activities with advanced technological & mechanical components integration inside engine environment (Inc. dedicated integration inside composite structure) in order to provide final background analysis / score card.

The applicant will have to study these integration aspects in order to further increase the technology readiness level and reinforce prospects for future aircraft engine application. Two sets of full scale low noise OGV demonstrators compatible with fan frame composite structure integration and requirements (defined in task2), will be developed and manufactured. Mechanical models of OGV will be performed and compare with one reference OGV in order to ensure compliances with environment (T°C) and mechanical requirements (static loads, dynamic, HCF-LCF, ...). Other aspects like weight, profile shape

accuracy, adverse environment compatibility, costs, maintainability and industrial feasibility, among others, will be considered by the applicant.

The full scale low noise OGV concept and associated technologies will be defined during design reviews (CoR, PDR and CDR). Compliance with specification provided by task 2 & WP2.1 will have to be validated through partial test targeting at least TRL3. To conclude a TRL review will be passed by the applicant.

3. Major Deliverables/ Milestones and schedule (estimate)

*Type: R=Report, D=Data, HW=Hardware, RM = Review meeting

Deliverables			
Ref. No.	Title – Description	Type*	Due Date
D1.1	Management plan & Risk reduction plan intermediate status	RM & R	T0 + 3 m
D2.1	Innovative Low noise OGV specification - OGVs demonstrators	RM & R	T0 + 6 m
D2.2	Innovative Low noise OGV specification completion – Full scale Engine integration	RM & R	T0 + 15 m
D3.1	Advance concepts screening & score cards of technologies report - Concepts selection for large scale stator	RM & R	T0 + 27 m
D4.1	OGV prototypes detailed definition – CDR	RM & R	T0 + 14 m
D5.1	OGV prototypes Hardware delivery & compliance status - TRR	HW, R & RM	T0 + 20 m
D6.1	OGV prototypes tests results & analysis	R & D	T0 + 24 m
D7.1	Advance modelisation final report – Low fan / stator stage full integrated simulations	R & D	T0 + 42 m
D8.1	Large scale stators CDR detailed definition – CDR review	RM & R	T0 + 32 m
D9.1	Large scale stators Hardware delivery & compliance status - TRR	HW, R & RM	T0 + 36 m
D10.1	Large scale tests results & performance analysis	R, D & RM	T0 + 42 m
D11.1	Full scale OGV detailed definition and studies – CDR	R & RM	T0 + 38 m
D11.2	Innovative Low noise stator integration inside engine environment studies, test results & hardware deliveries	R, D & HW	T0 + 48 m

Milestones (when appropriate)			
Ref. No.	Title – Description	Type*	Due Date
M1.1	Risk reduction plan Completion review	RM & R	T0+26 m
M3.1	Preliminary score cards of technologies report - Concepts selection for OGV prototypes	RM & R	T0+9 m
M3.2	Concepts selection for large scale stator	RM & R	T0+26 m
M4.1	OGV prototypes definition - PDR review	RM & R	T0 + 9 m
M6.1	Acoustic test matrix and aeroacoustics instrumentation for demonstrations	RM & R	T0 + 20 m
M6.2	OGV prototypes tests results review	RM & R	T0 + 22 m
M7.1	Advance modelisation intermediate report – aeroacoustics noise model for innovative technologies simulations effects	RM & D	T0 + 20 m
M8.1	Large scale stators definition – PDR	RM & R	T0 + 24 m

Milestones (when appropriate)			
Ref. No.	Title – Description	Type*	Due Date
M10.1	Test matrix, instrumentation review & UHBR large scale fan rig ready for large scale stators demonstrations	RM & R	T0 + 38 m
M11.1	Integrated design and components definition – CoR	RM & R	T0 + 20 m
M11.2	Full scale innovative OGV design and integration studies – PDR	RM & R	T0 + 30 m
M11.3	Full scale innovative OGV Hardware manufactured & compliance status - TRR	R, D & HW	T0 + 42 m
M11.4	Full scale innovative OGV integration inside engine environment demonstrator – TRL Review	RM & R	T0 + 48 m

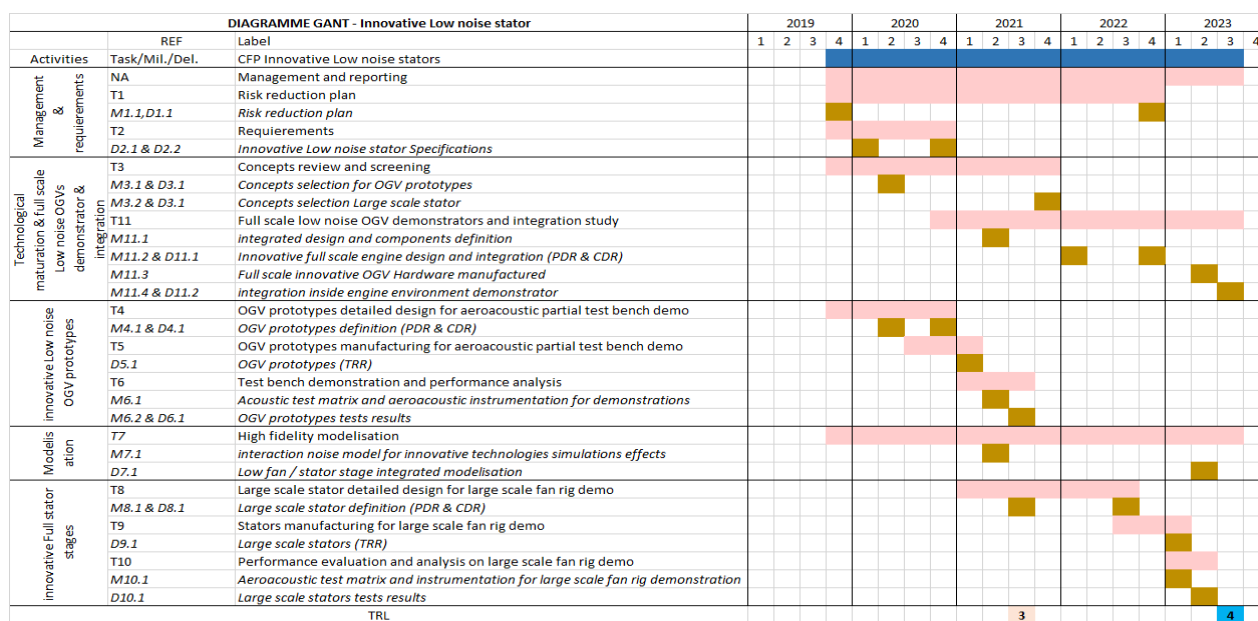

4. Special skills, Capabilities, Certification expected from the Applicant(s)

- Experience in design, manufacturing, testing of low noise OGV concepts including aeroacoustics aspects and absorbing material aspects (essential)
- Capacities to specify / identify / develop advance low noise OGV solutions for aeroacoustics (1) blade leading edge concept (aeroacoustics modelisation) (essential)
- Capacities to specify / identify / develop advance low noise OGV solutions for soft passive leading edge (2) and active leading edge (3) concepts (damping material, components) (essential)
- Experience in mechanics, composite, hybrid design, system and structure integration for Aircraft components
- Expertise in advance composite, specific material/shape and blade manufacturing
- Testing and inspecting: provisioning and testing individual components (such as motion sensor); testing PCM system (mechanical testing; hydraulic testing);
- Experience in noise interaction specific tests for OGV prototypes aeroacoustics characterization (essential). Availability of associated test benches
- Experience in large scale fan rig tests and acoustic / aerodynamic characterization (essential). Availability of associated test benches
- Expertise in High fidelity simulations to modelise aeroacoustics interaction noise, damping structure



and complete Fan module aeroacoustics

- The applicant shall provide adequate information necessary for an effective and efficient project management during the course of the project

5. **Abbreviations**

UHBR	Ultra High Bypass Ratio
CoR	Concept Review
PDR	Preliminary Design Review
PCM	Pulse Code Modulation
CDR	Critical Design Review
TRR	Technology Readiness Review
GEN	Generation
OGV	Outlet Guide Vane

IV. JTI-CS2-2018-CfP09-LPA-01-61: Fatigue life prediction on Inco 718 part subject to service induced damages

Type of action (RIA/IA/CSA):		IA	
Programme Area:		LPA	
(CS2 JTP 2015) WP Ref.:		WP 1.1.3	
Indicative Funding Topic Value (in k€):		650	
Topic Leader:	GKN Aerospace Sweden	Type of Agreement:	Implementation Agreement
Duration of the action (in Months):	36	Indicative Start Date (at the earliest)¹²:	Q3 2019

Topic Identification Code	Title
JTI-CS2-2018-CfP09-LPA-01-61	Fatigue life prediction on Inco 718 part subject to service induced damages
Short description	
<p>Models for calculating fatigue life of surface damaged safety critical rotating parts subjected to primary engine flows and service induced damages are to be developed. The surface damage may be classified as “nicks, dents and scratches” originating either from the manufacturing and assembly process or service induced, the damage is random in nature and variations in shape and residual stress state is therefore to be expected. The project aims to investigate the impact on fatigue on alloy 718 from a variety of damages. The goal of the project is to develop a methodology for life analysis from surface damages. The main variables affecting the life predictions need to be identified and included in the life model. Finally procedure to predict safe life (failure rate less than 0.1%) is to be developed.</p>	

Links to the Clean Sky 2 Programme High-level Objectives¹³				
This topic is located in the demonstration area:		Advanced Engine/Airframe Architectures		
The outcome of the project will mainly contribute to the following conceptual aircraft/air transport type as presented in the scene setter:		Advanced Long-range Ultra-advanced Long-range Advanced Short/Medium-range Ultra-advanced Short/Medium-range		
With expected impacts related to the Programme high-level objectives:				
Reducing CO₂ emissions	Reducing NO_x emissions	Reducing Noise emissions	Improving EU Competitiveness	Improving Mobility
<input checked="" type="checkbox"/>	<input type="checkbox"/>	<input type="checkbox"/>	<input type="checkbox"/>	<input type="checkbox"/>

¹² The start date corresponds to actual start date with all legal documents in place.

¹³ For further info see Chapter 1 “Introduction to the Programme Scene Setter / Objectives” with key technology themes / demonstration areas. Detailed information available in the CS2 Development Plan accessible via the Clean Sky JU Website and EC Participant Portal.

1. Background

Engine relevance: The drive for environmental improvements in air transport has led EU and the European aerospace industry to explore and develop Open Rotor engine architectures for reduced fuel consumption and reduced CO₂ emissions. The illustration to the right shows the SAFRAN CROR engine at the test stand in Istres, France in September 2017.

The Open Rotor engine is characterized by large counter rotating high speed propellers. These propellers are mounted to rotating frames that transmits torque and thrust at the same time as they act as a primary flow path for the engine core flow. Rotating frames are considered as an engine safety critical component and the structural durability requirements are very stringent since a failure in operation would endanger the aircraft.

The Open Rotor engine architecture - and specifically the rotating frames - are subjected to low cycle fatigue loads superimposed with higher frequency vibration loads. The implication is that the damages will develop into crack-like flaws and grow and therefore must be kept to limits with regard to initial flaw size, load cycle and stress state to ensure that the structure will be safe during its entire life.

Typically, durability of engine components is ensured by strict control of material quality and processing in combination with predictions of component life using experimentally verified models for predicting engine loads and detailed models for how the material behaves. In addition, probabilistic models taking into account variability of loads, material properties and model accuracy are emerging to quantify the probability of failure.

An improvement area with regard to the current life ageing approach has been identified and it addresses damages in the surface that may occur in the final stages of assembly, by foreign objects in the primary flow path hitting the component or surface damage induced during maintenance and inspection of the engine. These damages can be described as nicks, dents or scratches (NDS) that are visible or barely visible to the human eye. They are typically small and may be hard to characterize in shape and effect on local residual stresses around the surface damage. The Topic Manager intends to establish a physic based and experimentally grounded methodology to assess the impact on component life of these surface damages. The methodology will be used in the design phase but it can also be used in assessing findings during in-service inspection. The nature of the damages is such that a very large variety of shapes is possible. For any analysis to be possible a clear understanding on the main parameters that characterise the damage need to be understood. Thus a variety of geometrical features

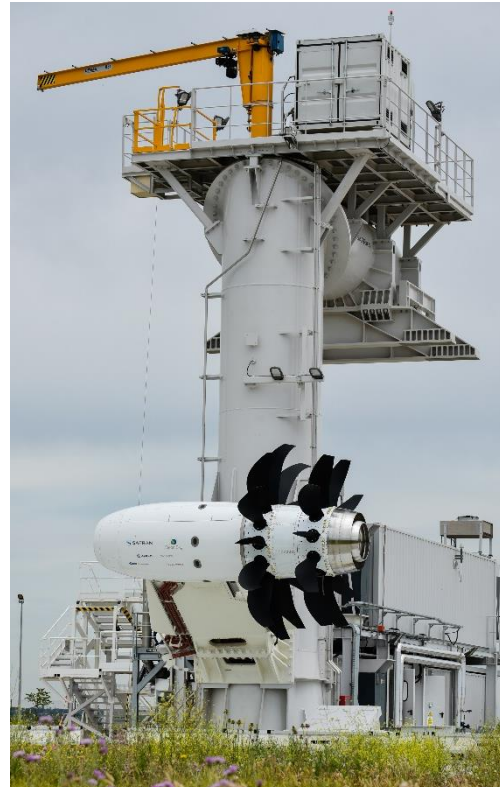

Open Rotor engine test in Cleansky 1



A rotating frame

need to be tested and characterised as for instance length, depth, root radius and width. Residual stress will be measured in the near vicinity of the damage using methods offering adequate resolution to resolve the stress field near the damage.

The final model will need the following inputs from the project:

- Geometry description of damage
- Residual stress field
- Propagation of one or several physically small cracks from the damage

Proposed workflow: The starting point for the model should be standard damage tolerance methods as included in the software in which fatigue life should be predicted using input from testing, with specimens with artificially induced damages representing nicks, dents and scratches in shapes and forms that are found in engines (to be defined with input from the Topic Manager). Experiments will be launched in two strands. The first strand intends to characterize the damage in detail with regard to geometry, residual stress and relation to - or effect on - the local microstructure. The second strand will determine the effect of the NDS defects by fatigue testing. The tests are to be conducted on standard specimens in forged Alloy 718 at minimum two temperature and two strain ranges for a population of defects that can generate data with statistical confidence.

Research aspects: The research aspects of the proposed topic are threefold and they are all related to aspects where the validity of continuum mechanics assumptions are questionable:

- 1) The geometrical scale of the defect is in the same size as the grain size
- 2) The residual stress field from the damage event may interact with crack propagation rate.
- 3) The defect event may change the local microstructure which may cause changes to local mechanical properties.

To further emphasise the need for advanced research it is proposed to include modelling of the physics involved to strengthen the understanding of the phenomena and to validate these models by for instance measurements that resolve residual stress fields around the small defects.

The final result of the project will be a deeper generalized understanding of NDS and their effect on fatigue life on critical engine components. Recommendations on how safe life - with a failure rate of less than 0.1% - can be predicted and recommendations for test procedures for quantitatively assessing additional alloys and materials forms should be included in the final report

Typically, these recommendations should define how to characterize these defects in a robust way in maintenance so that these measures directly can be used with the life assessment methodology. The impact of this research will be safer engine products and reduced cost for introducing new alloys and material forms in engine designs due to the generalized methodology that will be developed in this project.

2. Scope of work

Tasks		
Ref. No.	Title - Description	Due Date
1	<p>Literature review and definition of test case</p> <p>Literature review of available methods for</p> <ol style="list-style-type: none"> 1) Residual stress measurements techniques with spatial resolution better than 0.1 mm (to resolve stresses in the near vicinity of the damage) 2) Modelling of residual stress fields of the created surface damages. 3) Lifting methods of specimens or components having representative nicks, 	M6

Tasks		
Ref. No.	Title - Description	Due Date
	<p>dents and scratches.</p> <p>The literature review will be based on input from Topic manager regarding type and size of damages on engine parts.</p> <p>A review with Topic Manager will be held covering the results from the literature review (M6)</p>	
2	<p>Experimental set-up</p> <ul style="list-style-type: none"> • Develop methodology for creating damages • Develop methods to create surface damages <p>Define test specimen geometries</p> <p>The test variables are:</p> <ul style="list-style-type: none"> – Temperatures: Room temperature and 550oC are foreseen – Two impact energies to generate surface damage – Damages: Two types to be included in the project. The damages are here termed “sharp” or “blunt”. – Two sizes for each damage type – Number of test specimens; for each set of test parameters approximately 10 specimens are foreseen. <p>Test plans for both surface damaged specimens and material characterization (tensile test, crack propagation test, threshold tests) will be developd in this WP.</p> <p>Pre- test review of experimental techniques and test matrices (M9)</p>	M12
3	<p>Hardware for testing</p> <p>This WP will manufacture and deliver all test specimens for the project. It is expected that characterization of damages, residual stress measurements and mechanical testing will be run in parallell. Therefore more blanks will be prepared than what is needed for the fatigue testing.</p> <p>Examples of size and geometry of damages to be manufactured will be an outcome of WP2.</p> <p>Approximately 300 specimens will be produced from rod material, covering:</p> <ul style="list-style-type: none"> – Fatigue testing of surface damaged specimens – Specimens for characterisation (geometry) – Specimens for residual stress measurements – Spare specimens – Specimens for generating crack growth curve – Specimens to generate input data for FE-simulations <p>The main deliverables from this WP is:</p> <ul style="list-style-type: none"> • Procurement of test material (approx 40 meters, 24 mm diameter Inconel 718 bar material (AMS 5663)). Cost for material shall be covered by the project. • Manufacturing of test specimens for material characterization. • Manufacturing of test specimens with surface damages. <p>The test specimens shall be manufactured according to the requirements in NADCAP checklist AC7101/7. The code Z apply for the tensile test specimens and the code Z2 apply for the crack propagation test specimens as well as the specimens with surface damages.</p>	M15

Tasks		
Ref. No.	Title - Description	Due Date
	A review of test specimens will be held with the Topic manager before delivery of all test specimens is completed (M15).	
4	<p>Characterization of damages</p> <p>This WP will deal with the characterizatoin of the damages. The characterisation of damages will be done using three methods.</p> <ul style="list-style-type: none"> • Characterize the geometry of damages (~80 samples) • Characterization of residual stress fields (~20 samples) • Perform NDT/NDA of damages with standard FPI and visual inspection used in the aerospace industry. <p>This WP will run in parallell with the methods development and mechanical testing.</p> <p>A review of the results with the topic manager will be held before final report on the WP is delivered (M20).</p>	M21
5	<p>Mechanical testing</p> <p>Tensile and fatigue test results are the main deliverable of this WP.</p> <ul style="list-style-type: none"> • Fatigue testing of specimens with surface damages • Deliver results from conventional testing for characterizing base material • Load levels: One LCF load and one HCF load and possibly a simplified spectrum load. <p>Fatigue testing of specimens with surface damages shall be performed at a laboratory complying to the general requirements in ISO 17025. The conventional testing (tensile, crack propagation and crack propagation threshold) shall be performed at a laboratory holding NADCAP or ISO 17025 accreditation for these test methods.</p> <p>The magnitude of this WP is in total circa 200 test results</p> <ul style="list-style-type: none"> • A review of test results and progress will be done continuously invloving Topic manager. A final review of test results will be held after conventional testing is completed (M12) and of fatigue testing of the surface damaged specimens (M21) 	M24
6	<p>Numerical analysis</p> <p>The main deliverable of this WP is modelling of surface damages and fatigue life predictions of surface damaged specimens. It is currently believed that residual stress fields need to be both modeled and included in the fatigue life model. The WP is divided into:</p> <ul style="list-style-type: none"> • Material model calibrations • Model development for residual stress calculation • Model development for life calculations • Analysis of test results • A review of the model and lifing predictions will be held towards the end of the WP (M27). • Modelling of prediction uncertainties 	M33

3. Major Deliverables/ Milestones and schedule (estimate)

*Type: R=Report, D=Data, HW=Hardware, M = Minutes from the Meeting

A project outline is shown below:

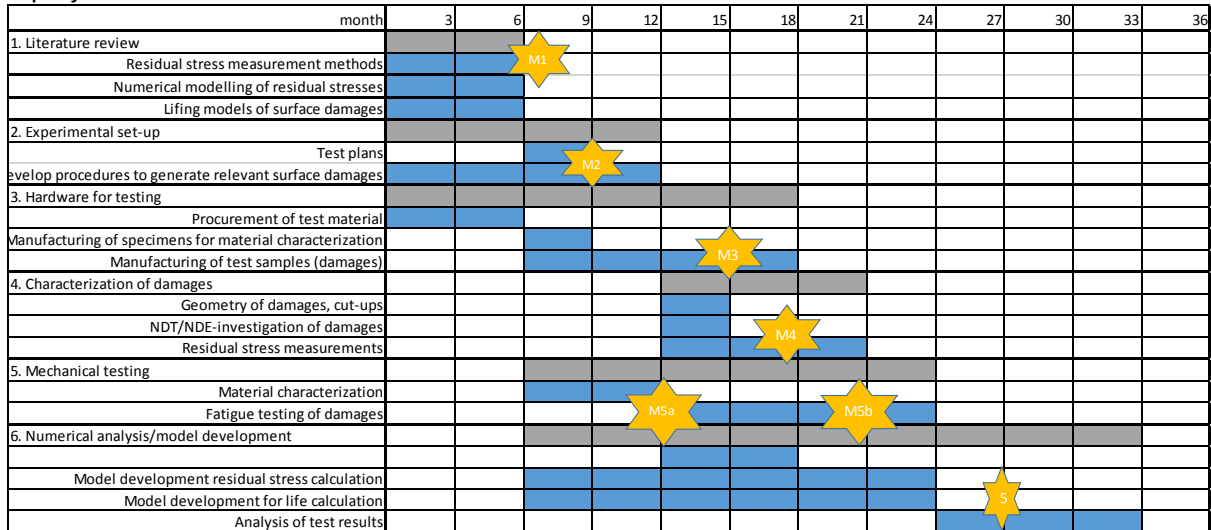

Deliverables			
Ref. No.	Title - Description	Type*	Due Date
D1	Detailed project plan	R	M1
D2	Literature survey as defined in Task 1.	R	M6
D3	Test plans delivered	R	M9
D4	Test specimens delivered	HW	M18
D5	Defects characterized (geometry, residual stress)	R	M21
D6	Total model for life prediction (test results and model)	R, D	M33
D7	Final report of results	R	M36

Milestones			
Ref. No.	Title - Description	Type*	Due Date
M1	Litterature review	M	M6
M2	Review of experimental set-up	M	M9
M3	Review of test specimen outcome	HW + M	M15
M4	Review of characterization of damages	M+D	M18
M5A	Review of material characterization	M	M12
M5B	Review of fatigue results, surface damages	M	M21
M6	Review of model for surface damage	M	M27

4. Special skills, Capabilities, Certification expected from the Applicant(s)

- The CfP partner/consortium should have equipment to perform fatigue testing in-house. The CfP partner/consortium should have experience in and ability to generate surface damages consistent with NDS.
- The CfP partner/consortium should have ability and experience in numerical simulations, especially



long experience in fracture mechanics. Especially experience in short crack-growth

- The CfP partner/consortium should be able to perform micro residual stress measurements
- The CfP partner/consortium responsible for crack growth modelling need access to NASGRO® or similar SW

5. Abbreviations

FPI	Fluorescent Penetrant Inspection
NASGRO(R)	Commercial Software issued by SwRI for Fracture Mechanics & Fatigue Crack Growth
NDS	Nicks, Dents, Scratches
NDT/NDA	Non-Destructive Technology/Non-Destructive Analysis

V. JTI-CS2-2018-CfP09-LPA-01-62: Rear End Structural Test Program – Component & Subcomponent tests

Type of action (RIA/IA/CSA):		IA	
Programme Area:		LPA	
(CS2 JTP 2015) WP Ref.:		WP 1.2	
Indicative Funding Topic Value (in k€):		1100	
Topic Leader:	Airbus	Type of Agreement:	Implementation Agreement
Duration of the action (in Months):	34	Indicative Start Date (at the earliest)¹⁴:	Q3 2019

Topic Identification Code	Title
JTI-CS2-2018-CfP09-LPA-01-62	Rear End Structural Test Program – Component & Subcomponent tests
Short description	
In the frame of the Advanced Rear End, this topic deals with the Component & Subcomponent tests of the test pyramid (from level 2 to 3) to demonstrate the feasibility of novel design concepts, materials & processes.	

Links to the Clean Sky 2 Programme High-level Objectives¹⁵				
This topic is located in the demonstration area:		Advanced Engine/Airframe Architectures		
The outcome of the project will mainly contribute to the following conceptual aircraft/air transport type as presented in the scene setter:		Advanced Short/Medium-range		
With expected impacts related to the Programme high-level objectives:				
Reducing CO₂ emissions	Reducing NO_x emissions	Reducing Noise emissions	Improving EU Competitiveness	Improving Mobility
<input checked="" type="checkbox"/>	<input type="checkbox"/>	<input type="checkbox"/>	<input type="checkbox"/>	<input type="checkbox"/>

¹⁴ The start date corresponds to actual start date with all legal documents in place.

¹⁵ For further info see Chapter 1 “Introduction to the Programme Scene Setter / Objectives” with key technology themes / demonstration areas. Detailed information available in the CS2 Development Plan accessible via the Clean Sky JU Website and EC Participant Portal.

1. Background

The Work Package 1.2 in LPA aims at the development of concepts, enabling technologies and capabilities for the design and manufacture of the optimum rear fuselage and empennage for the next generation of commercial aircraft.

Within WP1.2, the Advanced Rear End (ARE) demonstrator will be developed and tested to demonstrate the integration of novel conceptual design, structural and systems architectures, materials technologies and industrial processes. The ARE will involve large aircraft parts incorporating novel materials and structural concepts, and made entirely from CFRP using automated processes.

In this regard, representative Structural testing at coupons, details, sub-components and component tests level is needed to validate the industrial/design concept feasibility of the Rear Fuselage and Empennage, up to TRL5.

The objective of this topic is to design and manufacture the test benches and to complete the test program for the Component & Subcomponent tests (from level 2 to 3) of the test pyramid.

This topic is complementary to the topic “Rear End Structural Test Program - Low level tests”, being also part of the same call for proposal.

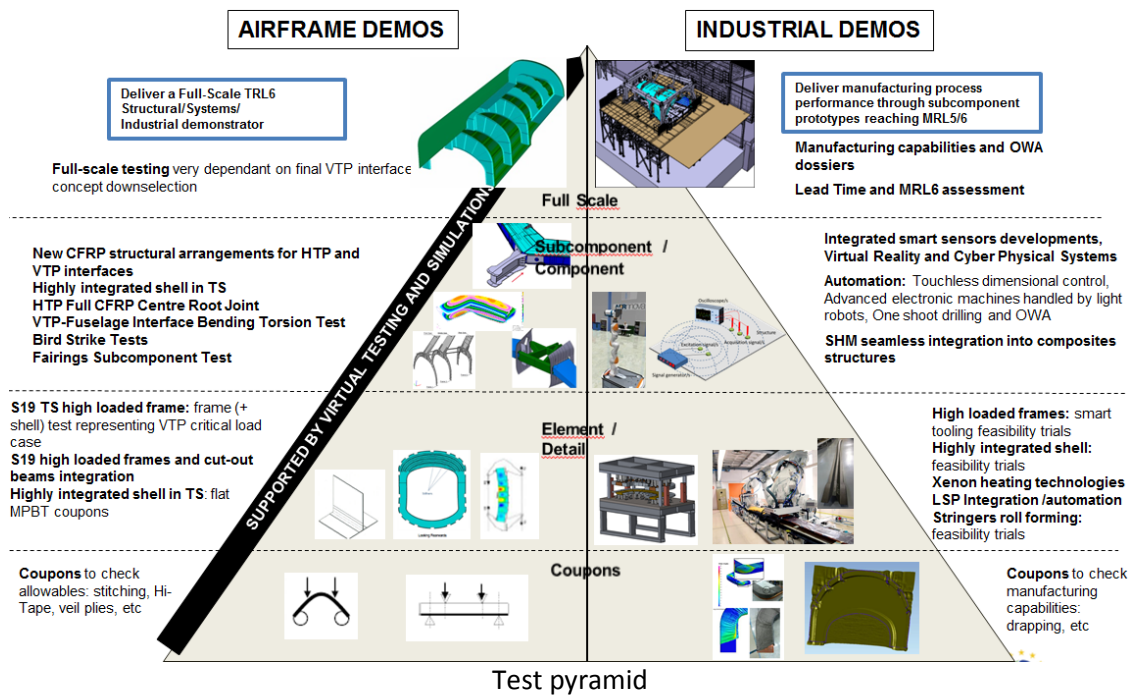

The Applicant(s) will be responsible to design the setup and processes to be developed to complete test performance phase. The proposed approach will have to rely on innovative solutions/ methodologies/ approaches that will be implemented on a series of tests defined in this topic.

This topic calls for innovative solutions and approaches to be implemented on the requested tests. The implementation of new approaches is required in order to demonstrate Innovation in Structures, Test Performance such as Virtual Testing, High Speed Measurement Data, Big Data Analysis Results, Wireless strain gauge to radio telemetry converter, Measure in real time of the interlaminar fracture toughness for CFRP parts, Optical Measurement and others technologies that the applicant may consider as appropriate.



Additionally, due to the novelty of the materials and structural concepts proposed (never tested before), the set-up design will play an important role in this final physical demonstration.

New testing techniques will be investigated and proposed in the implementation of the testing methodology and data acquisitions, such as data in real time from non-contact metrology, remote test monitoring system, automatic testing systems as well as test methods specially developed for each type of loading are used to characterize the mechanical properties of fiber-reinforced composites thermo plastic minimizing uncertainty of measurement.

Virtual testing is a current trend in the industry which aims to speed up and reduce the size of the certification campaigns performed to achieve the certification of an aircraft. Virtual testing will require an additional effort during the conception of the tests as the link between analysis and test should be much more intimate; in the near future the analysis will not be performed just to understand how the test behave because the test itself would be conceived thinking in the information needed by the virtual testing tool and not only trying to reproduce the working conditions of the structure. Virtual testing implementation involves several challenges not completely solved related to the validation and the limit of validity of the virtual model. Virtual tests require to use well calibrated and accepted material cards and validated models well correlated with experimental tests.

The work requested for the applicant will be the experimental verification by means of Structural Test of the components and subcomponents (see Section 2) developed by means of thechnobricks in the WP12 Advanced Rear End from TRL3 at completion (TRL4/6).

2. Scope of work

The applicant is expected to test the representative Structural Parts of the Advanced Rear End with the clear objective to validate by test the Structural Concepts, technologies, materials and manufacturing processes developed in the WP12.

The applicant is responsible to perform the Test Setup design and manufacturing of all test rigs, test actuators and all required hardware and software for the test. The applicant will perform all these tests and compile the test results.

The manufacturing and delivery of the Specimens are under the Topic Manager responsibility for all the tests.

The following table shows a summary of the tests required in this proposal and all the associated relevant data.

Test	Type of Test	No. Spec			Test Definition	Duration	Load/No.Jacks	No . Channels
T10	Static & Fatigue	1	At least 10 per specimen	Visual + NDT	Highly Integrated shell	12 months	max 5MN /10	500
T11	Static & Fatigue	1			New CFRP structural Arrangements for HTP and VTP interfaes	24months	max 5MN /10	500
T12	Static & Fatigue	2			HTP Full CFRP centre Root joint	24months	max 5MN /10	500
T13	Static & Fatigue	1			VTP Fuselage interface Bending	24months	max 5MN /10	500
T14	Impact Test	4			Torsion Test	12months	max 5MN /10	100
T15	Static	1			Bird Strike Test	12months	max 5MN /10	500
					Fairing Subcomponent Test			

TEST 10: Highly integrated shell in TS

- Requirements: Static and fatigue test.
Test Specimen is shown below as reference, final definition will be confirmed at the project start.
- Context: The skins of the Rear Fuselage of the latest Airbus Models are made of composites but the highest level of integration in thermoset materials considers nowadays only the cocuring of stringers into the skin. The next step in terms of integration is to manufacture a highly integrated panel including not only the skin and stringers but cocuring as well the contour frames. Therefore a Static & Fatigue test is required of the Specimen (see sketch) including a highly integrated panel (frames+stringers+skin) to validate/check potential impact on postbuckling policy.
- Expected Outputs: the Test Campaign will establish the contribution for the design of the Highly Integrated shell in order to validate the efficiency of this configuration. Innovative remote monitoring system is expected to reduce testing cost and maximize the involvement of experts in the test evaluation. It is also expected to implement full-field strain measurement solution and develop test methodologies to improve the identification of error sources in the test setup to minimize the test uncertainty, reduce testing times and non-quality costs. Better test accuracy will also allow better correlation with virtual models.
- Expected Innovation: The applicant will perform the test with innovative methods to improve crack/debonding onset and propagation detection. Moreover, other innovations that can be proposed are non-contact metrology to provide measurement data in real time along the test execution, methodologies to identify real boundary conditions to update virtual testing bench, wireless strain gauge to radio telemetry converter and remote test monitoring service to follow-up the test in real time. In this way more continuous information in the whole specimen will be obtained and the time required for sensors installation and cost associated to test control will be reduced. Additionally, due to the novelty of the materials and structural concept proposed (never tested before), the set-up design will play an important role in this final physical demonstration so previous identification of real boundary conditions to update virtual testing bench must be proved.

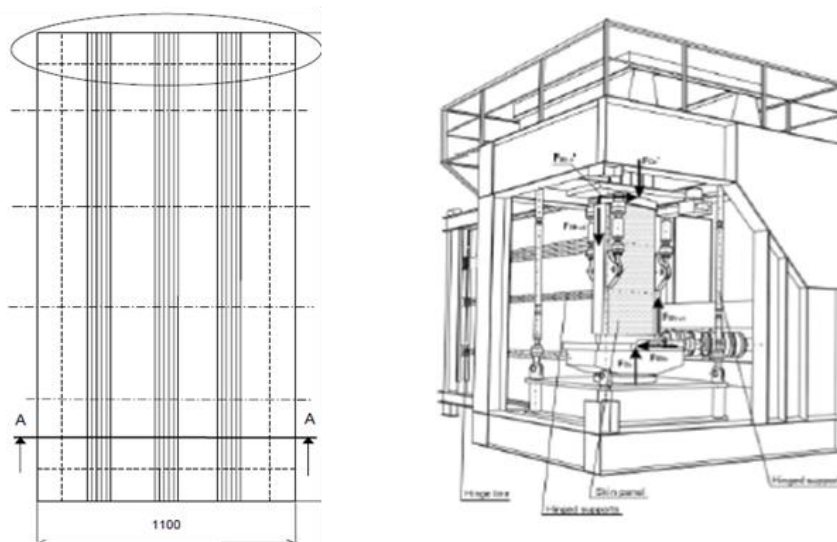

S19 Highly integrated shell (only as reference)

TEST 11: New CFRP structural arrangements for HTP and VTP interfaces

- Requirements: Static and fatigue tests to be performed.
Specimens will consist of new structural arrangement for S19 to VTP interface and new structural

arrangement for S19 upper shell linked to a HTP configuration with two lateral boxes. Both concepts will be confirmed at the project start.

- Context: in current commercial airplanes the high load introduction to the rear fuselage by the VTP consists typically of a multi lug joint made of machined aluminium alloy. The connection between Rear Fuse and HTP consists typically on three points interface. The complexity of the structural arrangement linked to these interfaces represents an important contribution for the total weight and recurring costs of the component, being the main challenge the application of composites in highly loaded frames, fittings, beams and in general safety-critical parts.

This hybrid configuration (composite skins and metallic frames and reinforcements) produces significant drawbacks and challenges in terms of weight penalty and manufacturing cost

The new Designs proposed in the WP12 are based on new development of the S19-HTP-VTP connections with the objective of reducing the cost and lead time associated to these interfaces, together with a full composite structure implementation.

A Static & Fatigue test is required of the Specimen (see sketch) to validate/check:

- New load paths to transfer VTP and HTP loads to S19
- Unfolding clips removal due to improved load transfer

Static and fatigue tests to be performed.

- Expected Outputs: the Test Results will establish the contribution for the design validation of the new CFRP structural arrangement associated to the new interfaces proposals.
- Expected Innovation: The applicant will perform the test with innovative methods to improve crack/debonding onset and propagation detection. Moreover, other innovations that can be proposed are non-contact metrology to provide measurement data, identification of real boundary conditions to update virtual testing bench, wireless strain gauge to radio telemetry converter and remote test monitoring service by internet. In this way more continuous information in the whole specimen will be obtained and the time required for sensors installation and cost associated to test control will be reduced. These solutions will require an innovative tool design to maximize the sensed area. Additionally, due to the novelty of the materials and structural concept proposed (never tested before), the set-up design will play an important role in this final physical demonstration so previous identification of real boundary conditions to update virtual testing bench must be proved.

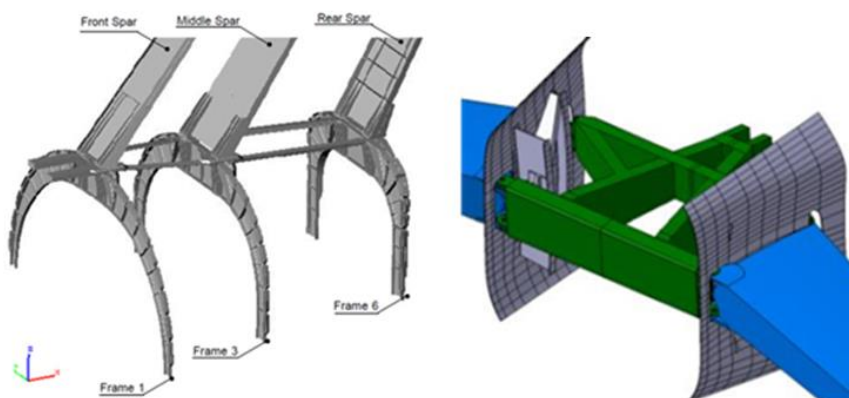

S19 – HTP and S19-VTP Interfaces (only as reference)

TEST 12: HTP Full CFRP Centre Root Joint

- Requirements: Static + Fatigue, mainly bending & torsion. Technical validation of new HTP interface structural solution for MultiSpar Horizontal Stabilizers Centre Joint by means of Static and fatigue testing

Specimens: two torsion boxes (@3m) joint together (See sketch)

- Context:
For the HTP the main structure consists of two composite torsion boxes that are joined together by means of a single shear junction (central Root joint), which is currently a hybrid metallic/composite solution. The proposed development is to reach a full composite structure removing all high-loaded metallic reinforcements and reducing the amount of mechanical joints, in order to achieve weight and cost savings. The main goal is to perform the structural validation from R&T perspective of the new HTP interface structural solution, and related manufacturing and assembly process, by means of a subcomponent test supporting static and fatigue loads.
- Expected Outputs: the Test Results will analyze in order to validate from structural perspective the proper behaviour of the new structural solution for the HTP Center Joint, including the tear-down of the specimen to identify/confirm the failure root cause.
- Expected Innovation: Classical test based on Inertia + Pressure Loads for New subcomponent test set-up (typically, this validation is done at Full-Scale level) but innovative methods of test must be taken into account as Correlation of real measurements with Acoustic + Video + Loads “Live” Correlation vs DFEM predictions, 1st Failure Quick Location, together with Live Crack Growth monitoring. Use of Structural Health Monitoring, including physical and/or wireless connections.

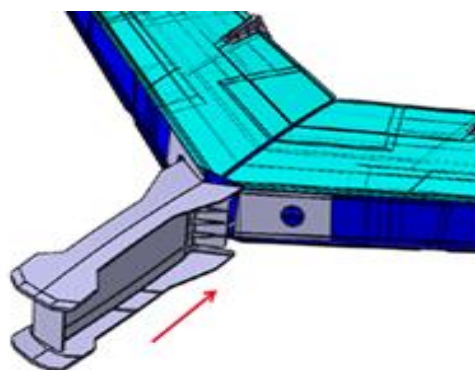

HTP Full CFRP Center Root Joint (only as Ref.)

TEST 13: VTP-Fuselage Interface Bending Torsion Test

- Requirements: Static + Fatigue, mainly bending & torsion. Technical validation of new structural solution for the interface between a VTP multispar box and fuselage interface.
Specimen: Torsion box (@4m) joint by lugs to a dummy S19 Upper Shell
- Context: VTP/S19 structural arrangement is classically performed by means of lugs to attach the multi-rib torsion box to the upper shell of the fuselage built by means of high-loaded metallic frames and composite covers, involving a significant percentage of the overall aircraft weight and cost. The main goal is to validate from structural perspective two technical aspects:
 - A VTP MultiSpar Box (few longitudinal spars instead of several transversal ribs) attachment to the Rear Fuselage, analyzing not only the loads transfers even the local VTP behaviour
 - New structural solutions for the joint of the VTP to S19, minimizing both weight and cost thanks to optimum integration and extensive use of new composite technos.
- Expected Outputs: the Test Results will analyze in order to validate from structural perspective the proper behaviour of the new structural solution which will be developed to improve the S19/VTP in terms of cost and weight, together with the overall structural behaviour of a one-shot VTP Multispar integrating the interface lugs
- Expected Innovation: Classical test based on Inertia + Pressure Loads for new subcomponent test

set-up (typically , this validation is done at Full-Scale level) but innovative methods of test must be taken into account as Correlation of real measurements with predictions from Virtual Testing, Acoustic + Video + Loads “Live” Correlation vs DFEM predictions, 1st Failure Quick Location, together with Live Crack Growth monitoring, Use of Structural Health Monitoring , including physical and/or wireless connections.

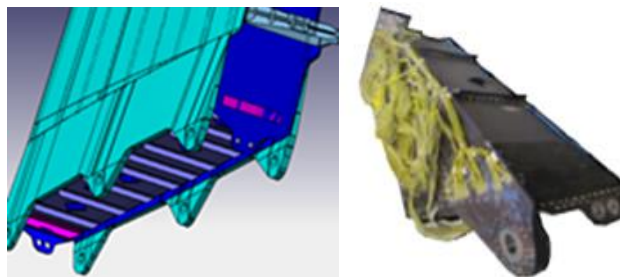

VTP Lugs used for S19 Attachment (only as reference)

TEST 14 Bird Strike Tests

- Requirements: 4 Bird Strike tests (real bird of 8lb with a speed of 185m/s following certification requirements) on Leading Edges critical areas, followed by correlation with Virtual Simulations, impacting on Leading Edges critical areas to validate from structural perspective the new integrated solution for the leadign edges of both Horizontal and Vertical Stabilizers
Technical validation of new HTP and VTP LE and S19 Structure Joint
Specimen: 4 multispar boxes with integrated LEs (2 from HTPs & 2 from VTP)
- Context:
Clasically, empennage leading edge are separate parts joint to the main torsion box by means of screws in order to enabler their assembly and disassembly
The new structural solution is integrating them together with a one-shot multispar box to achieve weigth, cost and drag reduction.
 - The main goal is to validate the impact resistance of this new new HTP and VTP Leading Edges and S19 Structure Jointntegrated solution from R&T perspective by means of the execution of several high energy impacts (real bird of 8lb with a speed of 185m/s following certification requirements) and their analysis and correlation with virtual simulations afterwards.
- Expected Outputs: the Test Results and their analysis will be used to validate from R&T perspective the new LE/Box integrated solution in front of high energy impacts.
- Expected Innovation: Classical test based on Inertia + Pressure Loads, but innovative methods of test must be taken into account as new impact test set-up, residual energy measure “in live”, implementation of new test technologies to minimize the number of “pre-tests” required prior to the final tests and/or wireless connections.



Leading Edge Bird Strike Impact test Simulations and Test Set-Up examples (only as reference)

TEST 15 Fairings Subcomponent Test

- Requirements: Static; mainly bending to check/correlate the overall displacements of a new empennage fairing solution (e.g. LEX, TIP, Dorsal Fin) of made of Short Composite Fiber Thermoplastic Injection Moulding
Specimens: One empennage fairing (e.g. LEX, TIP, Dorsal Fin)
- Context:
Empennage Fairings are currently made by means of metallic (forming + welding) and composite technologies (e.g. RTM), being very optimized in weight but not in cost.
New structural solutions are under investigation to replace existing production technologies by news ones which could be able to reduce the costs, the most promising one being the Short Carbon Fibre Thermoplastic Injection Moulding. Although this technology exists in automotive industry, its application to the aeronautics is not straightforward due to the different sizes and requirements needed by the aircrafts
The main goal of this structural test is to perform a preliminary validation of the design of an empennage fairing (e.g. Tip) using as specimen the outcome of some manufacturing trials, in order to confirm the robustness of the stress analysis and related DFEM by means of the correlation of the overall displacements obtained in the bending test.
- Expected Outputs: the Test Results will be used to validate the sizing of these new empennage fairings concepts manufactured by means of the Short Composite Fiber Thermoplastic Injection Moulding technology.
- Expected Innovation: Classical test based on Inertia + Pressure Loads, but innovative methods of test must be taken into account as new bending test set-up (classically, this validation is performed at full-scale size), Video vs DFEM “Live” displacements correlation by means of augmented reality, 1st Failure Quick Location, together with Live Crack Growth monitoring.



Empennage Fairings Location and DFEM Analysis examples (only as reference)

3. Major Deliverables/ Milestones and schedule (estimate)

Below you can find the Test schedule for all the tests (T10 to T15) explained in section 2, quoting the important deliverables CDR, TRR and Test Results and the time when it is expected. The target is to achieve Test Results before end 2022. These activities will be carried out in strong cooperation with the Topic Manager and the WP1.2 consortium.

Quality gates (KOM, PDR, Test CDR, TTR) are to be planned along the project in order to evaluate the go/no go activities of the project.

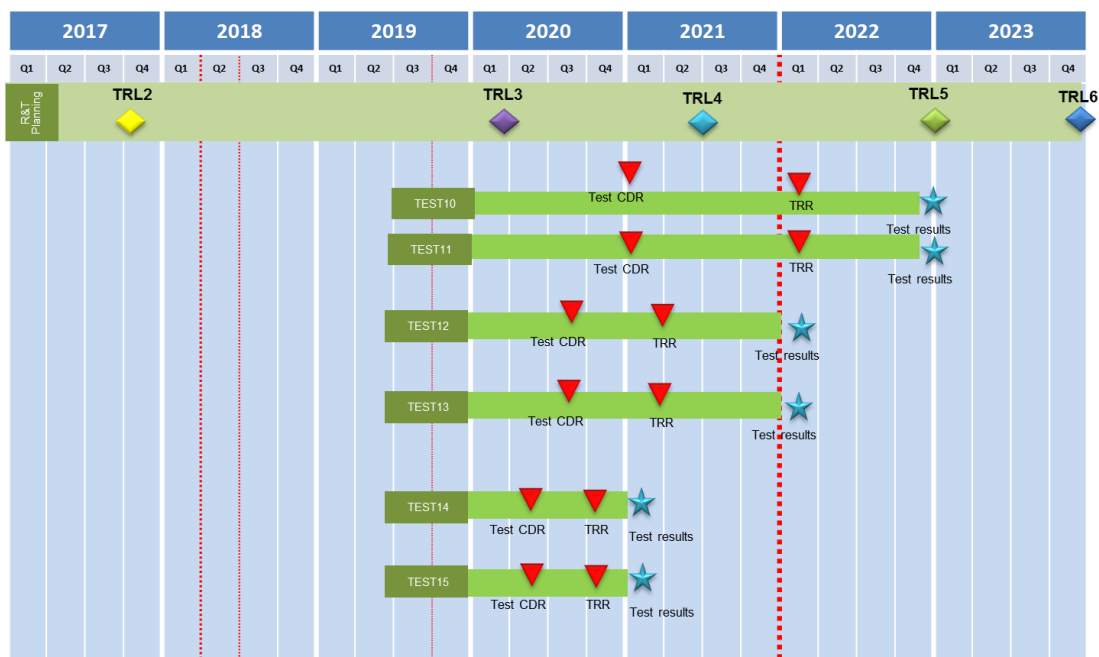

Test Schedule

Deliverables			
Ref. No.	Title - Description	Type	Due Date
D1.2.3-1	Test Plan (content, deliverables , planning)	Report	T0 + 6
D1.2.3-2	KOM Test Plan & Test Schedule (T10 & T15)	Data, Report	T0 + 6
D1.2.3-3	Review of Test Plan in preparation to the PDR for all the tests	Data, Report	T0 + 12
D1.2.3-4	Review of Test Plan in preparation to the CDR for all the tests	Data, Report, Drawing and Models	T0 + 24
D1.2.3-5	Review of Test Plan in preparation to the TTR for all the tests	Data, Report, Component	T0 + 24
D1.2.3-6	Release of Static Test data	Data, Report	T0 + 24
D1.2.3-7	Release of Fatigue Loading 1DSG phase data (TEST10, TEST11)	Data, Report	T0 + 24
D1.2.3-8	Release of Static Ultimate Load campaign data	Data, Report	T0 + 34
D1.2.3-9	Release of Fatigue 2DSG data	Data, Report	T0 + 34
D1.2.3-10	Test Report for all the TEST and release of associated data	Data, Report	T0 + 34



4. Special skills, Capabilities, Certification expected from the Applicant(s)

The applicant shall be able to demonstrate sound and widely recognized technical knowledge in the field of Structural Test:

- Extensive experience in the development of structural test benches and the completion of tests for Aeronautical Structures: Static, Fatigue and Damage Tolerance capabilities.
- It shall provide evidence of a sound technical knowledge, Project Management in “time, cost, quality and performance” together with evidence of substantial contribution in projects of the associated area.
- Experience in Structural Test Processes, managing and leading Major Structure. Quality and Accreditations as ISO9001 and 9100, NADCAP for Composite Test, NADCAP Non Destructive Testing and DOA with Aircraft Manufacturing Companies.
- Experience performing multi-axis tests (>15 jacks), experimental techniques availability: stereo-correlation, high speed video cameras, photoelastic coatings.
- Sound Project Management in “time, cost, quality and performance” together with an established track record in the associated area.

It would be highly desirable to broadcast test results over a secure network protocol to all the partners involved during the tests to facilitate the follow-up of the full test campaign.

In addition, the applicant should have the following facilities:

- Acquisition System with at least 1500 channels & Hydraulic & Control Sys to manage at least 20 Jacks
- Control and Data acquisition systems fully compliant with Aerostructures Tests specifications (synchronization, tolerance bands, hard and soft shutdown, etc.).
- Photoelasticity, Digital Image Correlation measurement system to displacement control in real time full field strain tracking and Remote Test Control Monitoring system to follow up tests in real time.
- Expertise and tools to correlate results from virtual and experimental tests.
- Hot/wet chambers for Structures Test
- In house, NDT Inspection technics for CFRP and Metal parts (with the appropriate qualification NDT Level2 or similar).

The applicant will provide Expected Innovation in Structural Test Procedures:

- The applicant selected for this proposal, will be the result of the combination between the skills/facilities required above and the Innovation in testing Methods and Setup Design presented in its proposal. All these technologies are additional to the ones tackled directly by Airbus (based on New Materials and New Manufacturing Processes for this WP12 Advanced Rear End) as resulting of the synergies will be established along the technology development project.
- Key of this proposal is to find an applicant combining the skills /certification required as it is explained above with an Innovation mindset/capabilities in testing methods and Setup Design i.e. virtual testing, remote test monitoring system, automatec testing systems as well as test methods to be specially developed for each type of loading.

5. Abbreviations

ARE	Advanced Rear End
CFRP	Carbon Fiber Reinforced Plastic
CDR	Critical Design Review



LE(X)	Leading Edge (Extension)
NDT	Non-Destructive Testing
PDR	Preliminary Design Review
SCFTP	Short Carbon Fiver Thermoplastic
TRR	Test Readiness Review
TP	Thermo Plastic
TS	Thermo Set
VTP	Vertical Tail Plane

VI. JTI-CS2-2018-CfP09-LPA-01-63: Rear End Aerodynamic and Aeroelastic Studies

Type of action (RIA/IA/CSA):		RIA	
Programme Area:		LPA	
(CS2 JTP 2015) WP Ref.:		WP 1.2	
Indicative Funding Topic Value (in k€):		1250	
Topic Leader:	Airbus	Type of Agreement:	Implementation Agreement
Duration of the action (in Months):	36	Indicative Start Date (at the earliest)¹⁶:	Q3 2019

Topic Identification Code	Title
JTI-CS2-2018-CfP09-LPA-01-63	Rear End Aerodynamic and Aeroelastic Studies
Short description	
Exploration of innovative aerodynamic and aeroelastic devices, technologies and concepts of tail surfaces by means of CFD and validation by Wind Tunnel Testing aimed at improving the stability and control function of the empennage and thus reducing the size of the tails. Development, analysis, design and testing of specific aerodynamic devices and concepts to address identified physical phenomena in order to enable a significant increase in the aerodynamic and aeroelastic performance of tail surfaces.	

Links to the Clean Sky 2 Programme High-level Objectives¹⁷				
This topic is located in the demonstration area:		Enabling Technologies		
The outcome of the project will mainly contribute to the following conceptual aircraft/air transport type as presented in the scene setter:		Advanced Long-range Ultra-advanced Long-range Advanced Short/Medium-range Ultra-advanced Short/Medium-range		
With expected impacts related to the Programme high-level objectives:				
Reducing CO₂ emissions	Reducing NO_x emissions	Reducing Noise emissions	Improving EU Competitiveness	Improving Mobility
<input checked="" type="checkbox"/>	<input type="checkbox"/>	<input type="checkbox"/>	<input type="checkbox"/>	<input type="checkbox"/>

¹⁶ The start date corresponds to actual start date with all legal documents in place.

¹⁷ For further info see Chapter 1 "Introduction to the Programme Scene Setter / Objectives" with key technology themes / demonstration areas. Detailed information available in the CS2 Development Plan accessible via the Clean Sky JU Website and EC Participant Portal.

1. Background

Work Package 1.2 is devoted to the development of concepts, enabling technologies and capabilities for the design and manufacture of the optimum rear fuselage and empennage for the next generation of commercial aircraft.

The Advanced Rear End (ARE) concept, developed in the WP1.2, aims at the integration of conceptual and aerodynamic design, structural and systems architectures, materials technologies and industrial processes to help achieve new standards in economic, environmental and manufacturing efficiency and flexibility. A demonstrator of an Advanced Rear End will be developed and tested. This research topic will contribute to defining the optimal configurations that will allow to:

- Deliver the following performance improvements at component level with respect to the 2014 short range reference aircraft: 20% Weight reduction, 20% recurring costs reduction, 50% Lead time reduction;
- Reduce the fuel burn at aircraft level by 1.5% stemming from the previous goals;
- Deliver Digital Mock-Ups and Technical Definition Dossiers of an integrated Advanced Rear End.

The purpose of this research proposal is to identify, investigate and quantify aerodynamic and aeroelastic enablers to allow the size reduction of the empennage of a classical configuration and/or facilitate the consideration of alternative configurations driven by non-aerodynamic considerations (e.g. V-Tail and the family of Cross-tails). Several elementary technology bricks are proposed for study, including experimental testing, each with particular focus on the key aerodynamic design drivers of an empennage, stemming from its required functions.

2. Scope of the work

The applicants are expected to design in detail from first principles (using physics-based methods) specific shapes to obtain a desired aerodynamic or aeroelastic effect, as described in the body of the document. Various physical principles involve modulation of the boundary layer to delay flow separation or to use coherent flow structures in the separated regime to maintain the lift in the post-stall phase. With these principles in sight, there is plenty of freedom to exploit the various phenomena in order to maximise the efficiency of the tail and control surfaces.

Drivers		Enabling Technologies (test)
Stability	Increase Lift slope	- Optimized planform for each member of a family (Modularity) (1G)
	Increase flexible aero coefficients	- Aeroelastic tailoring of tails (2A) - Forward swept planforms (2A) - Planform coupling (2B)
Control	Delay stall	- VGs (1C) - LE Tubercles and shapes (1A) - Anti(de)ice: Graphene (1F) - Anti(de)ice: Plasma (4) - Tip devices (1B)

Drivers	Enabling Technologies (test)
Increase control power	<ul style="list-style-type: none"> - Non-constant HL position (1D) - Double hinge controls (1D1) - Plasma actuation (1E) - APEX/LEX (1D2) - Shark shapes on controls (1D) - Split controls (3A) - Tip devices (1B) - Passive blown controls (1H)

Physical drivers and tasks proposed to investigate them in order to obtain an improvement in the behaviour of tail surfaces (code in brackets corresponds to tests and associated numerical predictions to be carried out as described in this document)

In several cases this will require ability to perform CFD analysis around and after the onset of flow separation. Given the unsteady and non-linear nature of the flow near the maximum lift regime, state of the art CFD tools (RANS LES/DES and/or Lattice Boltzmann Methods –LBM) shall be used, based on the demonstrable experience and computational power of the applicant.

Four different Modular Wind Tunnel Models (MWTM) are proposed as described hereafter as a means to implement physically and validate experimentally the innovative shapes and devices, developed in most cases with the aid of modern Computational Fluid Dynamics (CFD) methods. This project explores three main innovation axes:

- Use of Computational Fluid Dynamics to generate aerodynamic shapes to modulate separated flows. This application has been out of the reach of designers until very recently and this project offers the opportunity to develop a “Digital Test Twin” model, whereby the results of CFD analysis can be tested in a rapidly prototyped Wind Tunnel Model and the results fed-back to update the design. The effective design of the expected shapes and concepts will require exercising significant creativity based on sound technical knowledge; there being ample scope for innovation and development of innovative analysis and design methods. Several of the concepts and shapes proposed are the subject of intense research worldwide (e.g., undulated leading edge shapes) and will enable the generation of knowledge and its effective dissemination.
- Aeroelastic tailoring and testing. High fidelity Fluid-Structure Interaction analysis will be used in order to obtain a full 3D shape of the deflected structure under aerodynamic load. This novel capability is essential to assess the transonic behaviour of the lifting surfaces under load. The numerically predicted shape will be compared with the experimental results which, in turn, will require the use of innovative measurement methods in order to determine the deformed 3D shape (these can range from laser scanners to stereo-photogrammetry and others). The combination of numerical prediction for variable sweep models with and without tailoring and the experimental validation will greatly enhance the state of the art in aeroelastic design and testing applied to tail surfaces.
- A very important topic of this project is the study of plasma actuation, both for the delay of flow separation and for the prevention of ice accretion. While the physics are relatively well known, an important focus of this project is on the integration of plasma actuators on realistic geometries and kinematics of tail surfaces. No application of plasma actuation is known in movable surfaces (as proposed here) and it is expected that a large body of knowledge will be developed around materials compatibility, effect of plasma on moving surfaces and wind tunnel testing of large components.

There will be a total of 4 modular and reconfigurable wind tunnel models allowing the study of several combinations of leading and trailing edge devices and technologies. An additional, innovation axis will be the digital manufacturing of the modular components, which, in the cases where plasma actuation is studied, will call for advanced metallic 3D printing technologies. The following sections describe the wind tunnel models and their research objectives.

Model 1 Technical Description and objectives

- Rigid model of a VTP-like surface (1.6m span (height)) with a stiff common backbone.
- Interchangeable leading and trailing edges and tip to study each concept described below.
- Using 3D printing and rapid prototyping techniques as far as possible.
- Model design and construction under applicant responsibility based on a basic geometry and specifications.

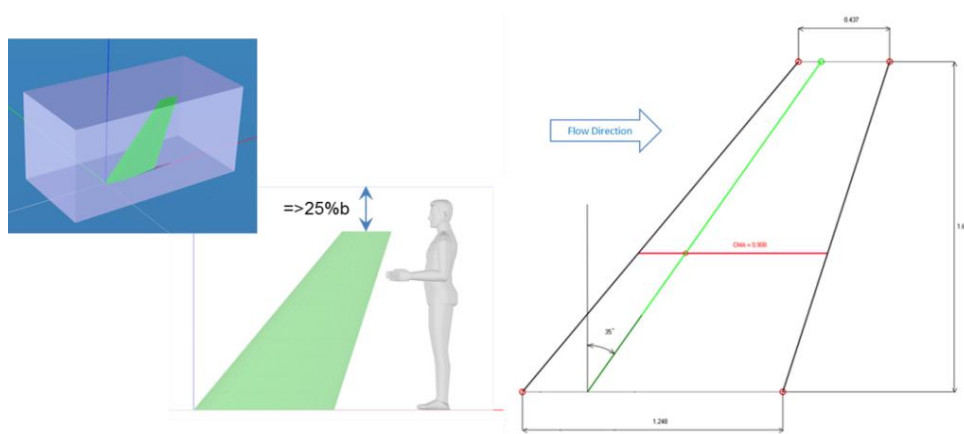

The general objective of the work on “Model 1” is to define and test technologies and shapes to delay the flow separation, leading to stall of the tail surface and saturation of the control surfaces. Additionally, power characterisation of graphene heaters as anti-ice devices will also be studied.

Use of non-linear aerodynamic effects (e.g., vortex generation with low drag devices, boundary layer modulation...), innovative technologies (e.g., plasma actuation) and novel concepts (e.g., passively blown controls) are in the scope of this activity. The Wind Tunnel Model will be fully modular in order to replace leading and trailing edge devices and shapes at low cost.

The applicant(s) will design and prototype models implementing a modular approach to easily adapt the configurations under test to assess the influence of the different elements.

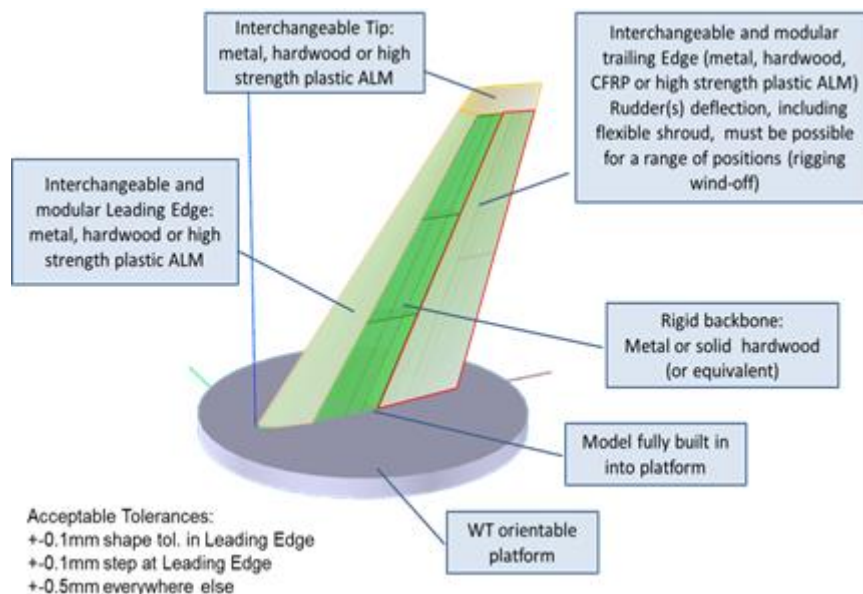

The devices which will be developed and studied are various as described below:

A: Study of curved Leading Edge shapes (dry) (1 Undulations, 2 Serrated sharp leading edges)

Objectives: The smooth leading edge undulations will interfere with the cross-flow, promoting a delayed flow separation while producing low drag in cruise. The final LE shapes will be designed by the applicant based on CFD in order to delay as much as possible the flow separation.

B: Tips, fences and end plates to increase CL slope and CLmax

Objectives: Fences and end-plate effects will delay tip stall and increase lift slope. The shapes will be designed by the applicant using CFD to increase CLmax and lift slope.

C: Low-drag vortex generators

Objectives: Leading edge shapes designed by the applicant based on CFD work in order to generate a stable vortex at high angle of attack but low drag in cruise. There is extensive academic literature on this topic and the goal is to produce a practical and optimized implementation of the concept.

D: Study of the effect of non-constant hinge line of a tail control surface (1 Partial span double hinge on a “shark” control surface. Secondary control can be locked for comparison purposes, 2 LEX effect on shark control)

Objectives: Maximum control power is limited by the stall of the lifting surface with controls deflected; an inboard-loaded double hinge control will delay flow separation by relieving load from the outer sections. A leading edge root extension should increase further the max Cl and control power due to the stable vortex. The tests will establish the additive contribution of each technology item. It is expected that innovative metal 3D printing techniques will be used for the manufacturing of the wind tunnel models.

E: Study of plasma flow control on tails and control surfaces (1 Dielectric Barrier Discharge actuators – DBD- for delaying flow separation of the rudder, 2 DBD on leading edge -round and sharp- to delay stall, 3 DBD on trailing edge, including Gurney flap concept)

Objectives: Maximum control power is often limited by the flow separation at the control surface hinge line. Re-energizing the flow with plasma actuation at the onset of separation will maintain it attached, delaying separation, therefore increasing aerodynamic force. The mechanisms, DBD actuators, signal shapes, amplification and associated equipment and the WT model will be designed and provided by the applicant. There is extensive academic literature on this topic and the goal is to produce a practical and

optimized implementation of the concept on geometries and with materials typical of commercial aircraft.

F: Study of graphene heating effect on leading edge surfaces

Objectives: Graphene heaters will be tested to characterise energy consumption and thermal profiles for different flow velocities. Graphene sheets will be provided by Airbus, the WT model will be designed and provided by the applicant, who will apply innovative IR thermography or equivalent means to characterise the behaviour.

G: Modular planforms

Objectives: Innovative flow visualization methods shall be used to characterise the stall mechanism and validate CFD methods and predictions of modular planforms.

H: Passive Blown controls

Objectives: Adding energy to the surface flow at the hinge line of the control is known to delay the flow separation and hence increase maximum control power. This test will validate 2 passive blowing concepts (one proposed by Airbus and one by the applicant) for which 2 modular rudder models embodying the concepts will be manufactured, installed and tested. The respective aerodynamic shapes and WT models will be designed by the applicant.

Model 2 Technical Description and objectives

The overall objective of this model and associated work is to study means and concepts to increase aeroelastic efficiency of tail surfaces using computational and experimental means.

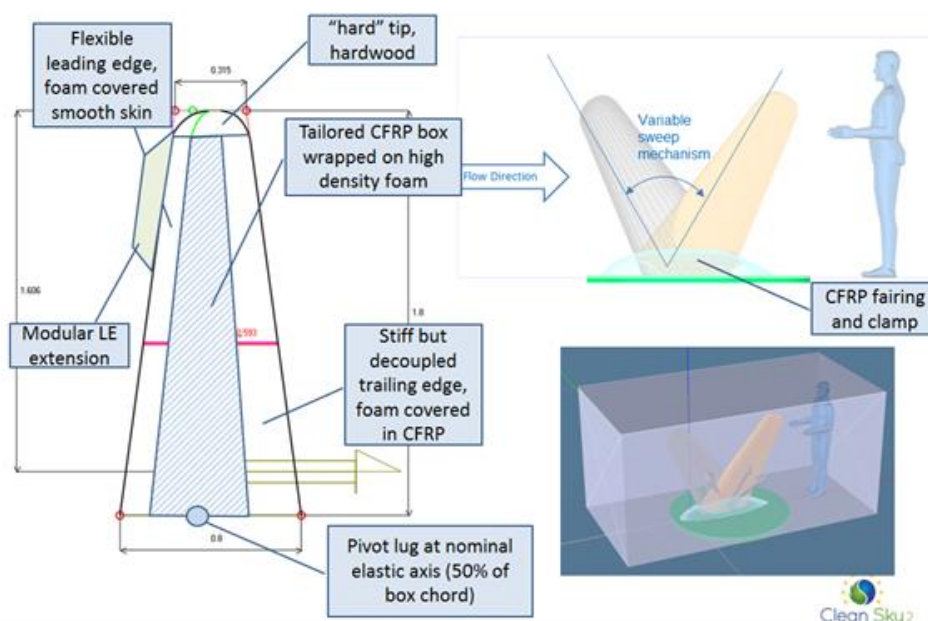

Two modular aeroelastic (flexible) models of the tail surface connected to a common support which allows a change in sweep angle will be studied:

- One model will not have bending-torsional coupling (as in current design practice)
- A second model will be aeroelastically tailored (the orientation of the CFRP cover properties will seek favourable bending-torsional coupling)

The model will be a VTP-like surface (the model will be as large as possible –minimum span of 1.6m–depending on WT offered by applicant). The provided model will have variable sweep (+-35deg),

adjustable at the wind tunnel, wind-off. An aerodynamic fairing will cover the pivoting and clamping mechanism.

The WT model will be designed and manufactured by the Topic Leader and provided to the applicant, who will characterise it mechanically as follows:

- Determination of elastic axis and global stiffness (including couplings) of the models by testing;
- Determination of full 3D deformation under aerodynamic load using optical measurements or equivalent for comparison with high fidelity CFD/FEM analysis carried out by the applicant.

The devices and concepts which will be developed and studied are various, as described below:

A: Aeroelastic tailoring of tail surfaces to promote favourable bending-torsional coupling to increase flexible CL-alpha slope

Objectives: In the forward-swept configuration, favourable aeroelastic behaviour (increased lift slope) is sought in order to make the tail surface more efficient in stability. For any sweep angle, the aeroelastic tailoring should also increase the flexible lift-slope. The purpose of the test is validation of first principles and calibration of design methodology, including high-fidelity FSI carried out by the applicant, as well as development of innovative 3D shape measurement methodology.

B: Platform-induced favourable bending-torsional coupling to increase flexible CL-alpha slope

Objectives: The aeroelastic effect induced by the modified planform will increase the slope of the elastic lift-angle of attack curve. The purpose of the test is the same as in the previous case. A modular Leading Edge extension for the WT model will be designed by the applicant and provided by the Topic Leader. The applicant will characterise the model behaviour numerically using high fidelity FSI and experimentally in the wind tunnel.

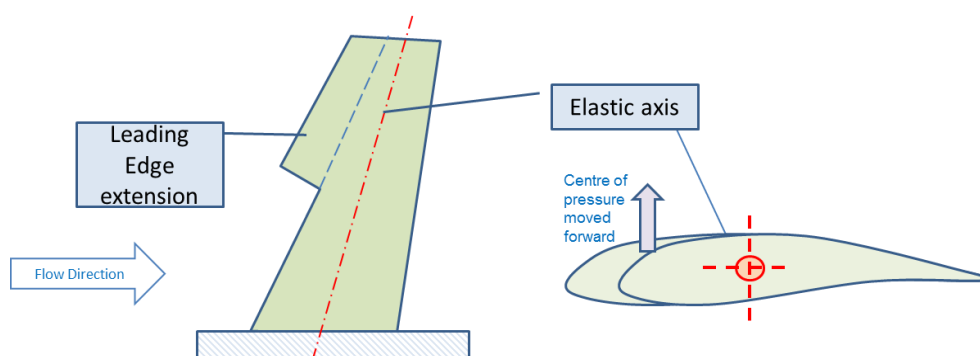

Model 3 Technical Description and objectives

The overall objective of this model and associated work is the integration study of all technologies on an advanced rear-end configuration and numerical prediction and post-test calibration. The aerodynamic design and analysis, selection of enabling technologies and geometric details will be carried out by the applicant. Exploration of plasma DBDs for rear-fuselage drag reduction (proof of concept) is sought.

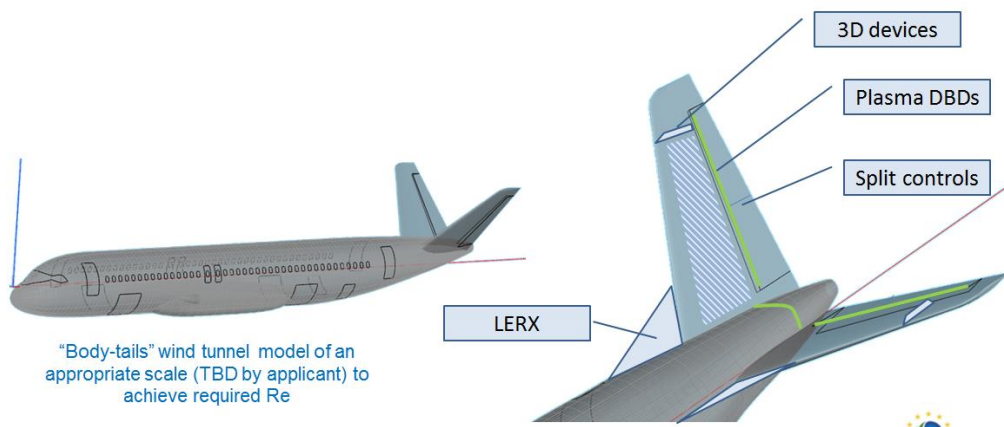

The wind tunnel model will consist of a body-tails model (with a shortened fuselage) with modular tails to represent a Reference and a V-tail configuration (selected as it presents many aerodynamic challenges for its feasibility). Several of the technologies and concepts to be developed in this project will improve the performance of this configuration which, in turn, will bring performance and industrial benefits at aircraft level.

Model definition and manufacturing will be under applicant responsibility based on general specifications (geometry, materials, tolerances) by the Topic Leader. Reynolds number at MAC of tails must be in the order of 1 Million in the wind tunnel.

Model 4 Technical Description and objectives

The overall objective of this model and associated work is the investigation of the applicability of plasma actuators (DBDs) for the combined effect of anti/d-ice devices and, as a secondary goal, for delaying stall.

Study of DBDs for anti-icing/de-icing (round and sharp LE)

Objectives: There is experimental evidence presented in the literature that plasma actuators can prevent ice accretion and even break the ice shapes. Application of DBDs on the LE of a tail surface will aim at both delaying stall and preventing ice formation. The goal of this task is to characterise the behaviour of plasma DBDs on a typical leading edge shape of a commercial aircraft tail, including materials, in order to assess the effectiveness as anti-ice system and explore the materials compatibility issues.

The aerodynamic shapes will be provided by the Topic Leader; DBD actuators and associated equipment and the WT models will be designed and provided by the applicant to be tested in an icing wind tunnel.

3. Major deliverables/ Milestones and schedule (estimate)

The main deliverables of this project are:

- Theoretical (CFD) studies leading to the design of specific aerodynamic devices to increase tails performance
- Wind tunnel data (raw and calibrated) corresponding to the tests performed on each of the devices and concepts
- Wind tunnel models manufactured with rapid prototyping methods
- Analysis of experimental data and correlation with numerical predictions

- Overall conclusions and recommendations

Deliverables			
Ref. No.	Title - Description	Type	Due Date
ARE_WTT_01	Partner contribution detailed description (content, deliverables, planning)	Report	T0 + 6
ARE_WTT_02	Model 4 Technical Description and test plan	Data, Report, Drawings and Models	T0 + 6
ARE_WTT_03	Model 2 Aeroelastic analysis of reference models and test plan	Data and Report	T0 + 12
ARE_WTT_04	Model 1 Technical Description and test plan	Data, Report and Drawings	T0 + 12
ARE_WTT_05	Model 4 Test results and analysis	Report	T0 + 15
ARE_WTT_06	Model 2 Test results and analysis	Data and Report	T0 + 18
ARE_WTT_07	Model 1 Final Technical Definition and WT models	Data, Report and Drawings	T0 + 24
ARE_WTT_08	Model 3 Technical Description and test plan	Data and Report	T0 + 24
ARE_WTT_09	Model 1 Test results and analysis	Data and Report	T0 + 34
ARE_WTT_10	Model 3 Test results and analysis	Data and Report	T0 + 34
ARE_WTT_11	Final report, conclusions and recommendations	Data and Report	T0 + 36

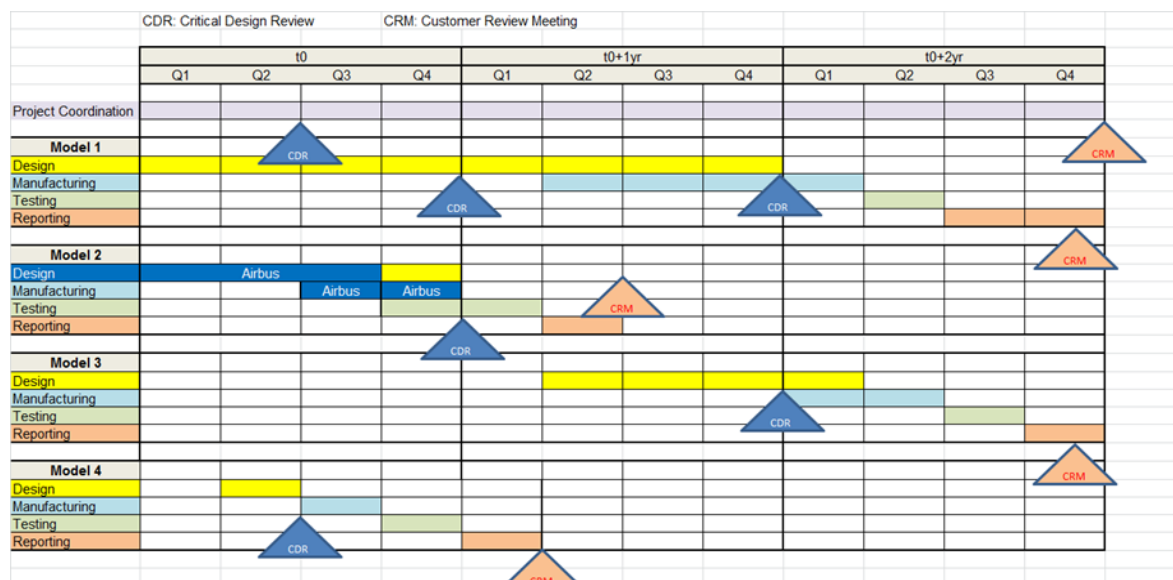

4. Special skills, Capabilities, Certification expected from the Applicant(s)

The applicant(s) shall be able to demonstrate sound and widely recognized technical knowledge in the following areas:

- Wind Tunnel Testing: low speed and aeroelastic applications
- Wind Tunnel Model design and build. In-house model manufacturing capability including installation of plasma DBDs and high quality 3D printing including metal and ceramic components
- Demonstrated experience with DBD plasma actuation including knowledge of safety procedures and

systems design aspects

- Excellent mechanical design capability applied to aeronautical projects. Knowledge of design standards, materials and tolerancing. CNC coding.
- Aerodynamic design experience and capability, including the modelling of massively separated flows and vortex flows (RANS LES/DES and or LBM)
- Demonstrated mechanical design capability to design WT models and mechanisms
- Demonstrated knowledge in innovative aircraft design, evaluation and research experience
- Demonstrated knowledge in aeroelastic analysis, design and testing

The applicant shall, as minimum requirements, use the following equipment for aerodynamic and aeroelastic design and testing:

- High Performance Computing (HPC) and state of the art CFD solvers.
- Low speed wind tunnel with the following characteristics:
 - minimum test section height of 2m,
 - minimum test speed 50 m/s,
 - Reynolds number at MAC (0.9m) must be greater than 2.5Million
 - Wind Tunnel model used by applicant shall have a turbulence level <0.5% and uniformity > 99%
 - Gap between model tip and wind tunnel top wall must be equal or greater than 25% of model height
 - force balance for lift, drag, pitching and yawing moment (at least)
 - surface flow visualisation
 - infra-red thermographic cameras
- Aeroelastic wind tunnel with the following characteristics:
 - minimum test section height of 2m,
 - nominal test dynamic pressure > 1500Pa
 - force balance for lateral force and drag
 - stereoscopic camera or equivalent (to determine deformed shape)
 - mechanical testing capabilities to characterise model stiffness including couplings
- Icing wind tunnel for a model with plasma DBD of a minimum chord of 300mm

5. Abbreviations

VG	Vortex Generator
CDR	Critical Design Review
HPC	High Performance Computing
LE, TE	Leading Edge, Trailing Edge
VTP	Vertical Tail Plane
DBD	Dielectric Barrier Discharge
WTT	Wind Tunnel Testing
MWTM	Modular Wind Tunnel Model
CFD	Computational Fluid Dynamics
LBM	Lattice Boltzmann Method
LEX	Leading Edge Extension
CFRP	Carbon Fibre Reinforced Plastic
MAC	Mean Aerodynamic Chord
Re	Reynolds number
FSI	Fluid-Structure Interaction



IR InfraRed
CL Lift Coefficient
CNC Computer Numerically Controlled

VII. JTI-CS2-2018-CfP09-LPA-01-64: Rear End Structural Test Program - Low level tests

Type of action (RIA/IA/CSA):		IA	
Programme Area:		LPA	
(CS2 JTP 2015) WP Ref.:		WP 1.2	
Indicative Funding Topic Value (in k€):		700	
Topic Leader:	Airbus	Type of Agreement:	Implementation Agreement
Duration of the action (in Months):	34	Indicative Start Date (at the earliest)¹⁸:	Q3 2019

Topic Identification Code	Title
JTI-CS2-2018-CfP09-LPA-01-64	Rear End Structural Test Program - Low level tests
Short description	
In the frame of the Advanced Rear End, this topic deals with the low level tests of the test pyramid (from level 4 to 6) to demonstrate the feasibility of novel design concepts, materials & processes.	

Links to the Clean Sky 2 Programme High-level Objectives ¹⁹				
This topic is located in the demonstration area:		Advanced Engine/Airframe Architectures		
The outcome of the project will mainly contribute to the following conceptual aircraft/air transport type as presented in the scene setter:		Advanced Short/Medium-range Ultra-advanced Short/Medium-range		
With expected impacts related to the Programme high-level objectives:				
Reducing CO ₂ emissions	Reducing NO _x emissions	Reducing Noise emissions	Improving EU Competitiveness	Improving Mobility
<input checked="" type="checkbox"/>	<input type="checkbox"/>	<input type="checkbox"/>	<input type="checkbox"/>	<input type="checkbox"/>

¹⁸ The start date corresponds to actual start date with all legal documents in place.

¹⁹ For further info see Chapter 1 "Introduction to the Programme Scene Setter / Objectives" with key technology themes / demonstration areas. Detailed information available in the CS2 Development Plan accessible via the Clean Sky JU Website and EC Participant Portal.

1. Background

The Work Package 1.2 in LPA aims at the development of concepts, enabling technologies and capabilities for the design and manufacture of the optimum rear fuselage and empennage for the next generation of commercial aircraft.

Within WP1.2, the Advanced Rear End (ARE) demonstrator will be developed and tested to demonstrate the integration of novel conceptual design, structural and systems architectures, materials technologies and industrial processes. The ARE will involve large aircraft parts incorporating novel materials and structural concepts, and made entirely from CFRP using automated processes.

In this regard, representative Structural testing at coupons, details, sub-components and component tests level is needed to validate the industrial/design concept feasibility of the Rear Fuselage and Empennage, up to TRL5.

The objective of this topic is to design and manufacture the test benches and to complete the test program for the Coupons test (Level 4-6) of the test pyramid.

This topic is complementary to the topic “Rear End Structural Test Program – Component & Subcomponent tests”, being also part of the same call for proposal.

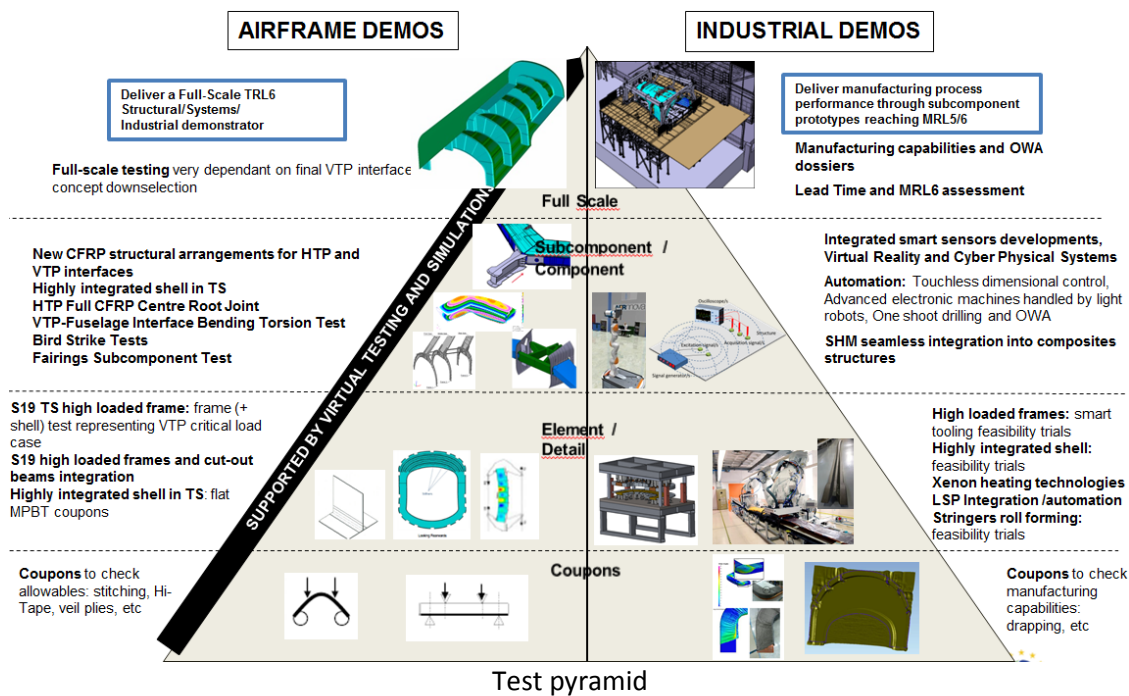

The Applicant(s) will be responsible to design the setup and processes to be developed to complete test performance phase. The proposed approach will have to rely on innovative solutions/ methodologies/ approaches that will be implemented on a series of tests defined in this topic.

This topic calls for innovative solutions and approaches to be implemented on the requested tests. The implementation of new approaches is required in order to demonstrate Innovation in Structures, Test Performance such as Virtual Testing, High Speed Measurement Data, Big Data Analysis Results, Wireless strain gauge to radio telemetry converter, Measure in real time of the interlaminar fracture toughness for CFRP parts, Optical Measurement and others technologies that the applicant may consider as appropriate.

Additionally, due to the novelty of the materials and structural concepts proposed (never tested before),

the set-up design will play an important role in this final physical demonstration.

New testing techniques will be investigated and proposed in the implementation of the testing methodology and data acquisitions, such as data in real time from non-contact metrology, remote test monitoring system, automatic testing systems as well as test methods specially developed for each type of loading are used to characterize the mechanical properties of fiber-reinforced composites thermo plastic minimizing uncertainty of measurement.

Virtual testing is a current trend in the industry which aims to speed up and reduce the size of the certification campaigns performed to achieve the certification of an aircraft. Virtual testing will require an additional effort during the conception of the tests as the link between analysis and test should be much more intimate; in the near future the analysis will not be performed just to understand how the test behave because the test itself would be conceived thinking in the information needed by the virtual testing tool and not only trying to reproduce the working conditions of the structure. Virtual testing implementation involves several challenges not completely solved related to the validation and the limit of validity of the virtual model. Virtual tests require to use will calibrated and accepted material cards and validated models well correlated with experimental tests.

The work requested for the applicant will be the experimental verification by means of Structural Test of the components and subcomponents (see Section 2) developed by means of thechnobricks in the WP12 Advanced Rear End from TRL3 at completion (TRL4/6).

2. Scope of work

The applicant is expected to test the representative Structural Parts of the Advanced Rear End with the clear objective to validate by test the Structural Concepts, technologies, materials and manufacturing processes developed in the WP12.

The applicant is responsible to perform the Test Setup design and manufacturing of all test rigs, test actuators and all required hardware and software for the test. The applicant will perform all these tests and compile the test results.

The manufacturing and delivery of the Specimens are under the Topic Manager responsibility for all the tests, except for T01 where the manufacturing and delivery of the specimens is under the Applicant(s) Responsibility, with the support of the Topic manager materials and processes and manufacturing departments.

The following table shows a summary of the tests required in this proposal and all the associated relevant data.

Test	Test Type	No. Spec	Insp No.	Level	Test Definition	Duration	Load/No.Jacks	No. Chansels
T01	CAIE, pull through unfolding and 4PBT	6spec /test/material	At least one per coupon	Visual and NDT	New TS prepreg characterization	6months	2 / max 1MN	50
T02	T-Joint Static and Fatigue	3spec /technology			Complex geometries integrated TP	6months	2/ max 1MN	50
T03	Static and Fatigue	2			TS high loaded frame	12months	6 / max 5MN	500
T04	Static Test	3			Highly integrated sheell in TS	3months	6 / max 5MN	100
T05	Static+ Fatigue and Static Test	2			TP countour frame	12months	6 / max 5MN	500
T06	Tensile and CAI plain Coupons	35°C frame spec and			CAI, TAI & Joggle tests	12months	6 / max 5MN	200
T07	4PBT Static	6			Net Shape Test	3months	6 / max 5MN	100
T08	Mechanical properties	6 spec/ test			Hybrid Material Characterization	6months	2/ max 1MN	50

TEST 01 - New TS prepregs characterization

- Requirements: Typical tests to be performed for stress related properties are (CAIE, pull-through,

unfolding and 4PBT).

- Context: The goal of these coupons tests is to characterize material properties for low cost prepregs and Hi-Tape material, including:
 - Physic-chemical properties of the raw materials as well as of the cured laminate
 - Mechanical properties (Dry and after aging)
 - Resistance to aggressive media
 - Paintability & Electrical Properties
 - Stress related properties & FST properties.
 At least 3 different materials will be tested.
- Expected Outputs: the Test Campaign will contribute to the design of the ARE in order to select the most efficient material reducing the number of test (and hence cost) and time, improving at the same time, the quality of the experimental data obtained in the test.
- Expected Innovation: The applicant will perform the test according to standard test procedure, but innovative methods to perform the test must be added i.e. Virtual Testing to reduce the number of specimens to be tested (including model validation to ensure quality of results) and quick detection of break layers interlaminar. These metrology innovations could require innovative tooling solution to allow cost reduction, a higher measurement quality and maximize the sensed area of the coupon.

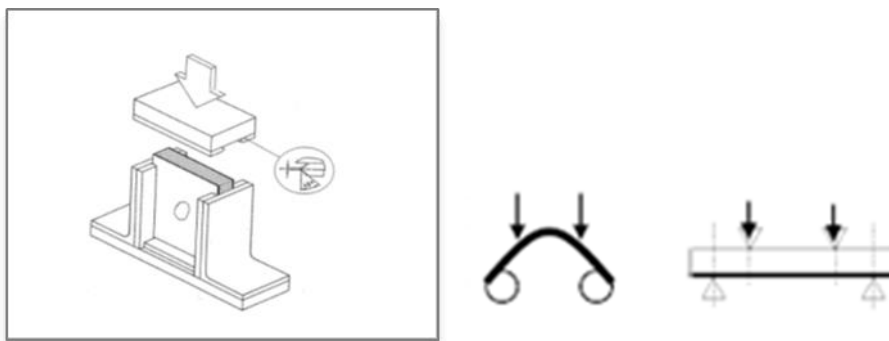

Example of CAI/TAI (left) and 4PBT test (right) (only as reference)

TEST 02 - Complex geometries integrated in TP

- Requirements: Test to compare T-joint vs L-joint structural detail. Static and fatigue tests are needed.
- Context: The goal of these coupons tests is to demonstrate the integration feasibility in TP for local load introduction areas, representing critical attachment details of the S19 high loaded frames and beams.
Different consolidation processes/proposals will be compared: autoclave, press, oven, etc.
- Expected Outputs: the Test Results will contribute to the design of the ARE in order to select the most efficient configuration in terms of integration, providing the results needed to compare different TP options vs TS one, to validate the interface behavior vs the load to be withstood.
- Expected Innovation: The applicant will perform the test according to standard test procedure, but innovative methods to perform the test must be added to improve crack/debonding onset and propagation detection and maximize the sensed area of the coupon. These metrology innovations could require in parallel, innovative tooling solutions to allow cost reduction, i.e. ALM rig manufacturing.

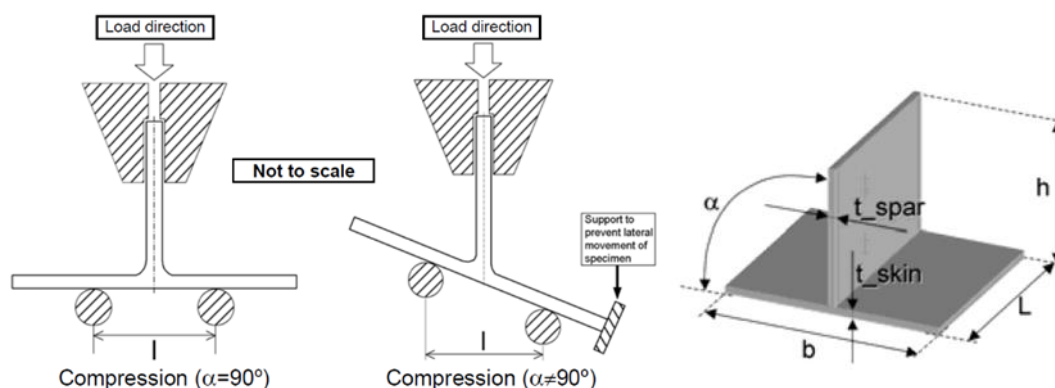

Typical Test Arrangement (only as reference)

TEST 03 - S19 TS high loaded frame

- Requirements: TS High Loaded CFRP Frame test (including a representative portion of the skin panel which this frame is attached to). Static and fatigue loads at room temperature and with no specific environmental conditioning
- Context: The objective of the test is to validate and correlate the analysis performed within WP12 for the definition of such a concept and quantify strength margins with regards to aircraft critical loading (VTP critical load case). The test specimen includes a representative S19 high loaded frame with a stiffened skin.
Additionally, due to the novelty of the materials and structural concept proposed (never tested before), the set-up design will play an important role in this final physical demonstration.
- Expected Outputs: the Test Results will contribute to the design of the ARE in order to validate this novel CFRP design for such a complex and loaded part. This test is one of the main pillars for WP12 since this new CFRP concept is an enabler for a full CFRP rear fuselage section, avoiding hybrid configurations. It is also expected to implement full field strain metrology solution and develop test methodologies to improve the identification of error sources in the test setup to minimize the test uncertainty, reduce testing times and non-quality costs. Better test accuracy will also allow better correlation with virtual models.
- Expected Innovation: The applicant will perform the test with innovative methods to have full-field metrology data, for example non-contact metrology to provide measurement data, identification of real boundary conditions to update virtual testing bench, wireless strain gauge to radio telemetry converter and remote test monitoring service by internet. In this way more continuous information in the whole specimen with higher measurement quality data, maximize the sensed area of the coupon will be obtained and the time required for sensors installation and cost associated to test control will be reduced. Additionally, due to the novelty of the materials and structural concept proposed (never tested before), the set-up design will play an important role in this final physical demonstration so previous identification of real boundary conditions to update virtual testing bench must be proved. Quality of the test results will be intimately linked to a good identification of the uncertainty sources.

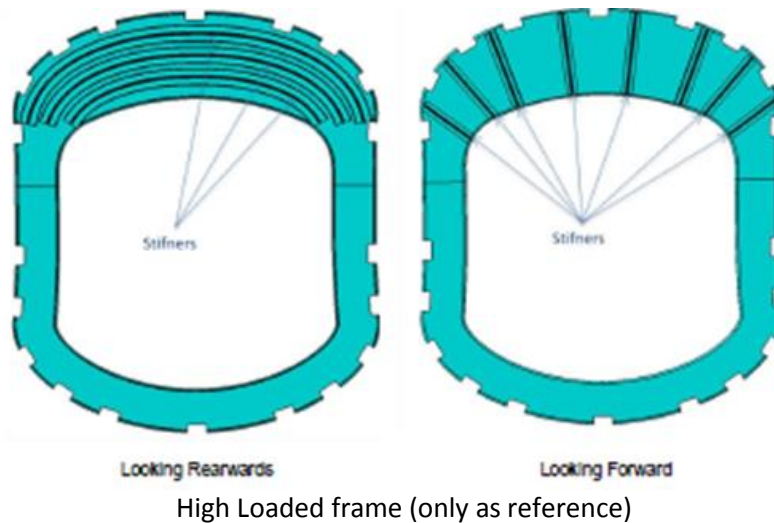

TEST 04 - Highly integrated shell in TS

- Requirements: Flat MPBT (Multipoint Bending Test) coupons/specimen to check frame radii behaviour (unfolding, debonding, etc.) under critical deformation or postbuckling scenarios.
- Context: The objective of the test is to validate qualitatively the structural behaviour of critical details of a highly integrated shell, where not only the stringers but the frames are integrated as well.
- Expected Outputs: the Test Results will contribute to the design of the ARE in order to select the most efficient configuration in terms of integration, getting a better knowledge on the behavior/performance of this novel and highly integrated concept. Cost and time could also be reduced by Virtual Testing solutions.
- Expected Innovation: The applicant will perform the test with innovative methods i.e. non-contact metrology to provide measurement data in real time in the whole specimen. Due to the novelty of the materials and structural concept proposed (never tested before), the set-up design will play an important role in this final physical demonstration so previous identification of real boundary conditions to update virtual testing bench must be proved. These solutions will require an innovative tool design to maximize the sensed area.

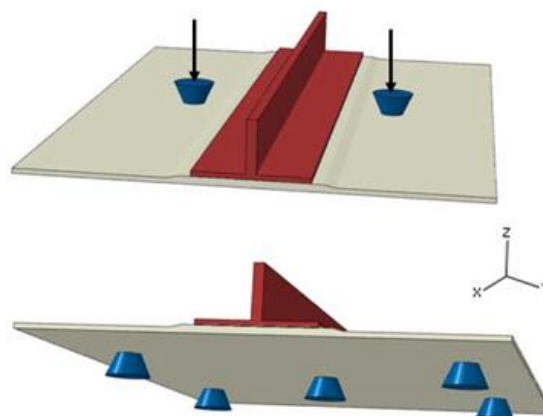

Example of MPBT for stringers is shown (only as reference)

TEST 05 - TP contour frame

- Requirements: The objective of the test is to confirm the performance of a contour frame with a new material (TP) and manufacturing process (stamping). Static and Fatigue Test at RT (Room Temperature) and with no specific environmental conditioning.
- Context: The test specimen includes a representative S19 contour frame with a stiffened skin and the objective is to validate these new material and process and quantify strength margin with regards to aircraft critical loading.
Loads and Spectra required for fatigue will be delivered by the Core Partner.
- Expected Outputs: the Test Results will contribute to the design of the ARE in order to select the most efficient configuration in terms of technology to be used for contour frames, confirming the behavior of the new material and process proposed. Innovative remote monitoring system is expected to reduce testing cost and maximize the involvement of experts in the test evaluation. In is also expected to implement full-field strain metrology solution and develop test methodologies to improve the identification of error sources in the test setup to minimize the test uncertainty, reduce testing times and non-quality costs. Better test accuracy will also allow better correlation with virtual models.
- Expected Innovation: The applicant will perform the test with innovative methods i.e. non-contact metrology to provide measurement data in real time along the test execution, methodologies to identify real boundary conditions to update virtual testing bench, wireless strain gauge to radio telemetry converter and remote test monitoring service follow-up the test in real time by internet. In this way more continuous information in the whole specimen will be obtained and the time required for sensors installation and cost associated to test control will be reduced. These solutions will require an innovative tool design to maximize the sensed area.

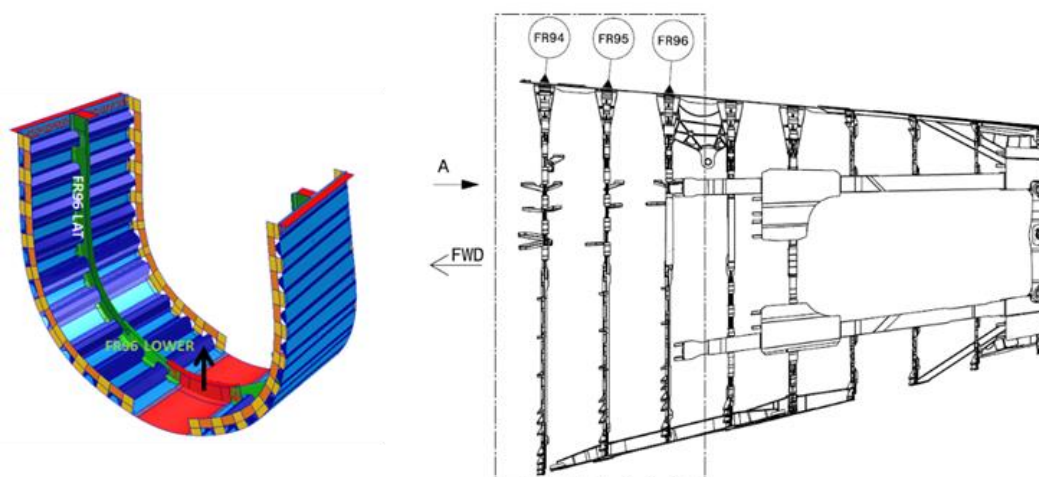

Example of Typical Frame Tests (only as reference)

TEST 06 - CAI, TAI & Joggle tests

- Requirements: A total of 35 “C” frame specimens and 46 plain coupons will be tested statically at RT/AR up to failure.
Coupons tests are tensile and CAI plain coupons.
C frame tests are requested for CAI-4PBT and TAI-tension. An example of CAI and TAI tests for different details to be tested, are shown in figures below.
- Context: The objective of the test is to check the potential impact on allowable due to new laminate configurations proposed as enablers for CFRP frames recurrent cost reduction.

- Expected Outputs: the Test Results will contribute to the design of the ARE in order to select the most efficient configuration in terms of frames laminate lay-up, with the aim of reducing the cost of the manufacturing process.
- Expected Innovation: The applicant will perform the test according to standard test procedure, but innovative methods to perform the test must be added i.e. Virtual Testing to reduce the number of specimens to be tested and model validation to ensure the quality of results. These solutions will require an innovative tool design to maximize the sensed area.

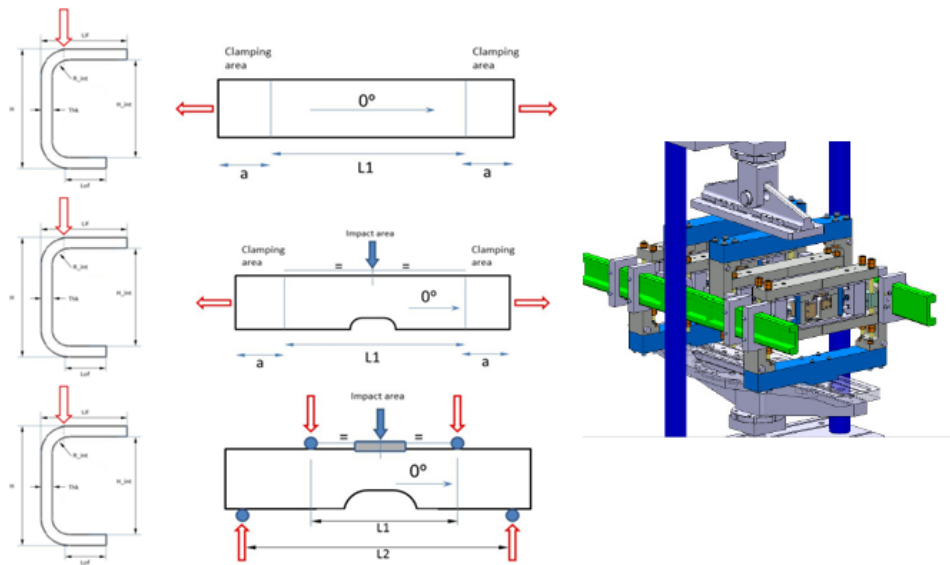

CAI / TAI examples (only as ref.)

4PBT rig (only as ref.)

TEST 07 - Net shape tests

- Requirements: 4PBT (4 point Bending Test) specimens will be tested statically up to failure.
- Context: The aim of these tests is to determinate net shape manufacturing influence on frame CAI allowable, to check if there is some impact on performance due to this manufacturing process modification (aiming RC reductions).
Each 4PBT specimen will be impacted, inspected (US inspections) and tested in static up to failure.
- Expected Outputs: the Test Results will contribute to the design of the ARE in order to validate if net shape manufacturing concept can be used in order to save recurring costs.
- Expected Innovation: The applicant will perform the test according to standard test procedure, but innovative methods to perform the test must be added i.e. Virtual Testing including model validation to ensure quality of the results, to reduce the number of specimens to be tested.

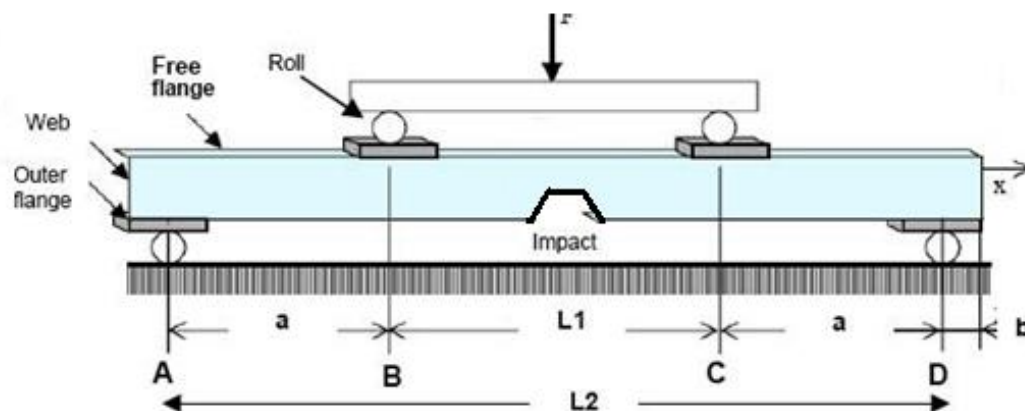

Typical 4PBT (only as reference)

TEST 08 - Hybrid material characterization

- Requirements: Characterization of hybrid material coupons including continuous reinforced plastics, produced by means of Additive Manufacturing.
- Context: The objective of the test is to perform all the necessary tests for characterization of hybrid material coupons by means of Additive Manufacturing technics, including:
 - Physic-chemical properties of the raw materials as well as of the cured laminate
 - Mechanical properties (Dry and after aging) including stress properties related to the interface between the materials (ILSS, F33 etc.)
- Expected Outputs: the Test Results will contribute to the design of the ARE in order to select the most efficient configuration in terms of panel stiffening means, getting a better knowledge on performance and allowable of hybrid CFRP materials configurations, as an enabler to reduce cost of the component skin panel.
- Expected Innovation: The applicant will perform the test according to standard test procedure, but innovative methods to perform the test must be added i.e. Virtual Testing to reduce the number of specimens to be tested, Non-contact metrology to provide Measurement Data in real-time along the test execution and new methodologies to reduce obtain more material parameters with less coupon.

3. Major Deliverables/ Milestones and schedule (estimate)

Below you can find the Test schedule for all the tests (T01 to T08) explained in section 2, quoting the important deliverables CDR, TRR and Test Results and the time when it is expected. The target is to achieve Test Results before end 2022. These activities will be carried out in strong cooperation with the Topic Manager and the WP1.2 consortium. Quality gates (KOM, PDR, Test CDR, TTR) are to be planned along the project in order to evaluate the go/no go activities of the project.

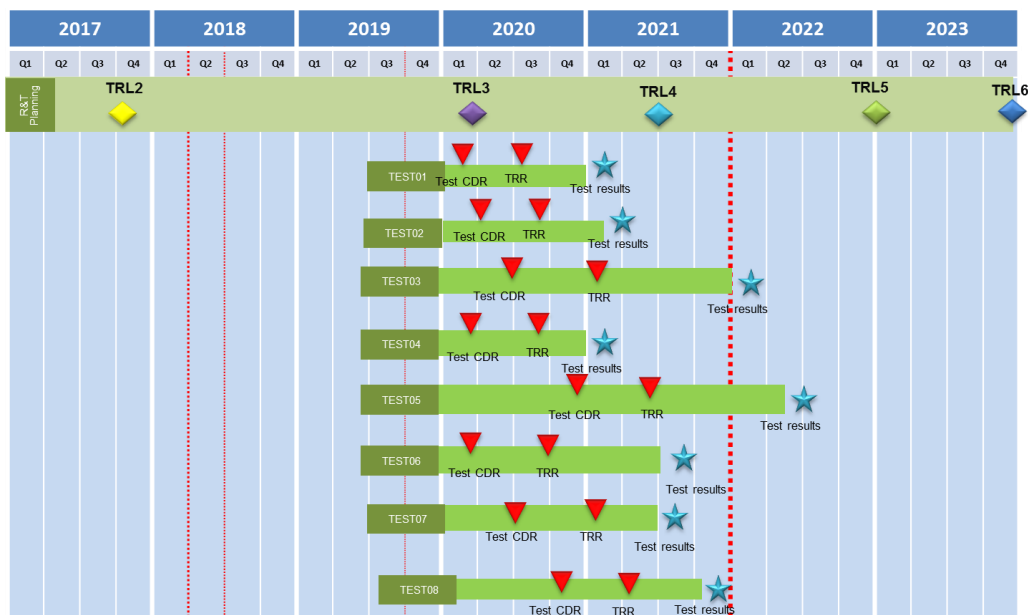

Test Schedule

Deliverables			
Ref. No.	Title - Description	Type	Due Date
D1.2.3-1	Test Plan (content, deliverables , planning)	Report	T0 + 6
D1.2.3-2	KOM Test Plan & Test Schedule (all tests)	Data, Report	T0 + 6
D1.2.3-3	Review of Test Plan in preparation to the PDR for all the tests	Data, Report	T0 + 12
D1.2.3-4	Review of Test Plan in preparation to the CDR for all the tests	Data, Report, Drawing and Models	T0 + 24
D1.2.3-5	Review of Test Plan in preparation to the TRR for all the tests	Data, Report, Component	T0 + 24
D1.2.3-6	Release of Static Test data	Data, Report	T0 + 24
D1.2.3-7	Release of Fatigue Loading 1DSG phase data (TEST02, TEST03 and TEST 05)	Data, Report	T0 + 24
D1.2.3-8	Release of Static Ultimate Load campaign data	Data, Report	T0 + 34
D1.2.3-9	Release of Fatigue 2DSG data	Data, Report	T0 + 34
D1.2.3-10	Test Report for all the TEST and release of associated data	Data, Report	T0 + 34

4. Special skills, Capabilities, Certification expected from the Applicant(s)

The applicant shall be able to demonstrate sound and widely recognized technical knowledge in the field of Structural Test:

- Extensive experience in the development of structural test benches and the completion of tests for Aeronautical Structures: Static, Fatigue and Damage Tolerance capabilities.
- It shall provide evidence of a sound technical knowledge, Project Management in “time, cost, quality and performance” together with evidence of substantial contribution in projects of the associated



area.

- Experience in Structural Test Processes, managing and leading Major Structure. Quality and Accreditations as ISO9001 and 9100, NADCAP for Composite Test, NADCAP Non Destructive Testing and DOA with Aircraft Manufacturing Companies.
- Experience performing multi-axis tests, Experimental techniques availability: stereo-correlation, high speed video cameras, photoelastic coatings.
- Sound Project Management in “time, cost, quality and performance” together with an established track record in the associated area.

It would be highly desirable to broadcast test results over a secure network protocol to all the partners involved during the tests to facilitate the follow-up of the full test campaign.

In addition, the applicant should have the following facilities:

- Acquisition System with at least 100 channels & Hydraulic & Control Sys to manage at least 10 Jacks
- Control and Data acquisition systems fully compliant with Aerostructures Tests specifications (synchronization, tolerance bands, hard and soft shutdown, etc).
- Photoelasticity, Digital Image Correlation measurement system to displacement control in real time full field strain tracking and Remote Test Control Monitoring system to follow up tests in real time.
- Expertise and tools to correlate results from virtual and experimental tests.
- Shakers and Hot/wet chambers for Structures Test
- In house, NDT Inspection technics for CFRP and Metal parts (with the appropriate qualification NDT Level2 or similar)

The applicant will provide Expected Innovation in Structural Test Procedures:

- The applicant selected for this proposal, will be the result of the combination between the skills/facilities required above and the Innovation in testing Methods and Setup Design presented in its proposal. All these technologies are additional to the ones tackled directly by Airbus (based on New Materials and New Manufacturing Processes for this WP12 Advanced Rear End) as resulting of the synergies will be established along the technology development project.
- Key of this proposal is to find an applicant combining the skills /certification required as it is explained above with an Innovation mindset/capabilities in testing methods and Setup Design i.e. virtual testing, remote test monitoring system, automatec testing systems as well as test methods to be specially developed for each type of loading.

5. **Abbreviations**

4PBT	Four Point Bending Test
ALM	Additive Layer Manufacturing
CAIE	Compression After Impact Edge
CFRP	Carbon Fiber Reinforced Plastic
CDR	Critical Design Review
MPBTB	Multipoint Bending Test
NDT	Non-Destructive Testing
PDR	Preliminary Design Review
TRR	Test Readiness Review
TP	Thermo Plastic
TS	Thermo Set
VTP	Vertical Tail Plane

VIII. JTI-CS2-2018-CfP09-LPA-01-65: Development of System pipework and Tooling for Sub-Assembly, Final-Assembly of the HLFC-wing Prototype

Type of action (RIA/IA/CSA):		IA	
Programme Area:		LPA	
(CS2 JTP 2015) WP Ref.:		WP 1.4	
Indicative Funding Topic Value (in k€):		700	
Topic Leader:	Aernnova	Type of Agreement:	Implementation Agreement
Duration of the action (in Months):	30	Indicative Start Date (at the earliest)²⁰:	Q3 2019

Topic Identification Code	Title
JTI-CS2-2018-CfP09-LPA-01-65	Development of System pipework and Tooling for Sub-Assembly, Final-Assembly of the HLFC-wing Prototype
Short description	
Development of innovative Tooling set for the HLFC-wing Prototype Specimen (calibrated with Functional Checks, Drilling templates, Handling, Sub-Assemblies, Final Assembly and Transportation), with integrated System pipework (HLFC Suction System & sub-systems, valves, standards, secondary structures, integrated design & hardware, manufacturing/procurement/installation & pre-test).	

Links to the Clean Sky 2 Programme High-level Objectives²¹				
This topic is located in the demonstration area:		Advanced Laminar Flow Technologies		
The outcome of the project will mainly contribute to the following conceptual aircraft/air transport type as presented in the scene setter:		Advanced Long-range		
With expected impacts related to the Programme high-level objectives:				
Reducing CO₂ emissions	Reducing NO_x emissions	Reducing Noise emissions	Improving EU Competitiveness	Improving Mobility
<input checked="" type="checkbox"/>	<input type="checkbox"/>	<input type="checkbox"/>	<input type="checkbox"/>	<input type="checkbox"/>

²⁰ The start date corresponds to actual start date with all legal documents in place.

²¹ For further info see Chapter 1 "Introduction to the Programme Scene Setter / Objectives" with key technology themes / demonstration areas. Detailed information available in the CS2 Development Plan accessible via the Clean Sky JU Website and EC Participant Portal.

1. Background

The enormous drag-reduction potential of HLFC (Hybrid laminar Flow Control) technology is key for the aeronautical industry and calls for the development of an innovative suction concept.

The design of an integrated and efficient suction system for HLFC is indeed a challenge to minimize the required suction power, along with the reduction of the associated weight.

This development must meet the airline requirement for installation-removal of an HLFC Leading Edge, and fully recover the laminar capabilities of the wing in a very reduced time-slot. At the same time, the integration of the suction system should be independent from the Leading Edge panel installation while having easy connection to it.

Therefore, this topic calls for applicant(s) who will prototype and demonstrate an integrative piping solution in the wing, and develop a tool for the wing integration.

The suction system can be active (driven by a pump), and/or passive, where a passive flap need to be integrated in the outer skin of the wing respecting its restrictive aero-tolerances.

Investigation has to be made to find the right combination and position in the wing, by either fully active, fully passive or a combination of both. The applicant(s) should be capable of developing both.

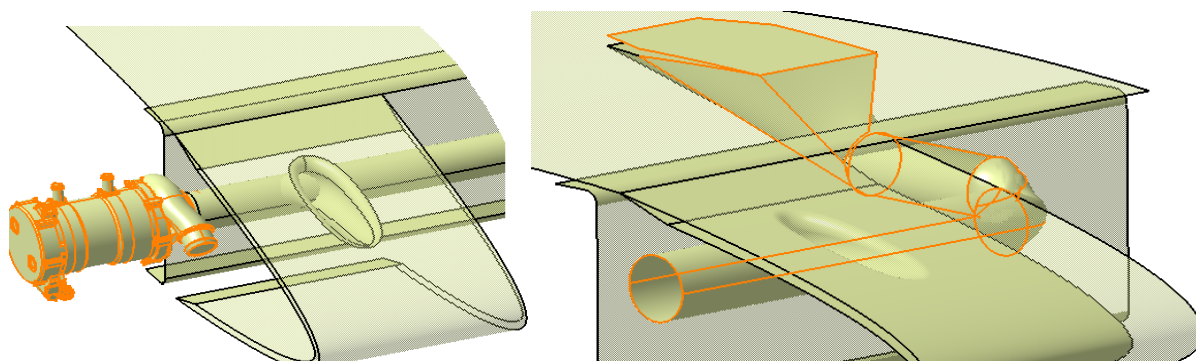

Figure 1: Schematic views of: Active System (left), and passive system piping integrated in some part of the wing (right)

With a natural laminar aerosurfaces of the aircraft, in our case applied to a wing, the boundary layer is very sensitive to wing surface quality imperfections and contamination. Therefore, the main challenge is to optimize the integrative pipework for the passive design and the assembly sequence to cope with the highest quality surface requirements with enough flexibility to give real-time manufacturing feedback of the measured data and having on-the-fly adjustments. That is in the end a Leading Edge easy replaceable and maintainable by the aircraft operator.

2. Scope of work

The applicant(s) has to join and participate in the concurrent engineering phase, to be aligned with the design assembly philosophy, challenges and support the first article; and is responsible for the detailed definition of an innovative Multifunctional Tool including the following aspects:

- Innovative Suction system for the active (with high speed compressor included) and passive (with actuation mechanism connected with strict aerotolerances in the outer skin) HLFC-Wing system solutions
- Sub-assembly operations
- Final assembly, Handling and transportation jigs and fixtures

The multifunctional tool will be developed through methods and tools for virtual pre-validation and physical testing, calibrated and with functional checks, for the Prototype – Wing Specimen (GBD). The tool must allow functional checks and installation-removal tests of the integrated systems in a tight confined space, fully compatible with the interfaces in the leading edge, root and wing tip.

The piping system will be in compliance with cascaded HLFC-Wing Top-Level-Requirements in terms of tolerances, weight, flow performance, Integration Tolerances piping-external surfaces, Noise and vibrations, minimizing PowerOutTake, Reliability, Replaceability, Aircraft Operational Requirements, etc.

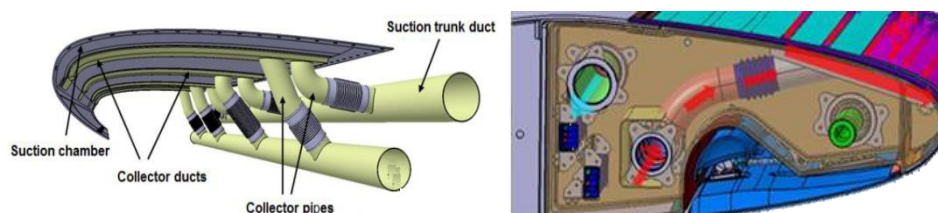

Figure 2: Schematic views of Suction Systems (non contractual geometry)

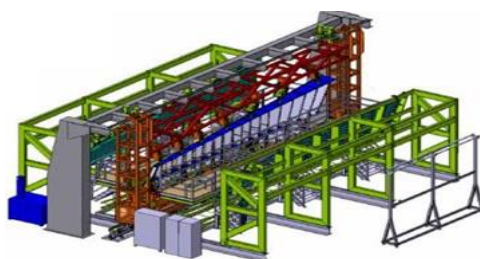

Figure 3: Schematic view of the required Tools (non contractual geometry)

The overall dimensions of the Prototype called “Wing specimen”, to be assembled with the tool and Suction system here developed, will be approximately 5 meters and will be delivered by the Topic Manager.

All detailed requirement for the piping system and the tool will be provided by the Topic manager (geometry, integration constraints, tolerances to be achieved, processes, quality level, etc).

The Applicant(s) will be responsible for the design and manufacturing of the final system pipework/toolings and different intermediate required tools/checks, and will deliver it in accordance with the required quality standard (along with technical justification, control report, etc).

The Applicant(s) should also be involved into the assembly process definition, in order to design the assembly tools in line with the sequence philosophy. The toolings has to be able to reproduce all the key parameters involved in the system pipework and product definition.

An innovative solution related with the sensorization of the assembly tooling (ie. Build-up stress and deformations measurements, automatic best-fit positioning, sensors recording key parameters to feedback engineering assumptions and calculations, Industry4.0, etc) and new manufacturing technologies for drilling templates, should be implemented; Also, it will help to the Quality control inspection of the final product and guarantee the Certificate of Conformity of the whole item.

The build up stresses is a key challenge and has to be properly monitored.

This Topic is divided in 6 main tasks summarized in the following table and described below; The Tasks and deliverables are fully aligned with the WP1.4.4.3 time-schedule, in order to build the Ground Based Demonstrator, in time, with all the inputs coming from the previous activities in this WP and in the rest of the HLFC-Wing workpackages:

Tasks		
Ref. No.	Title - Description	Due Date
T1	Plateau phase-Concurrent engineering	T0 + 6M
T2	Active suction system design (preliminary tool integrative aspects definition)	T0 + 12M
T3	Passive suction flap and sub-systems and internal tooling design	T0 + 16M
T4	Main Tool Design and validation process (CDR) with aeronautical standards	T0 + 18M
T5	Manufacture, Delivery, installation of the complete tooling set	T0 + 24M
T6	Assistance during assembly and functional test (GBD)	T0 + 30M

During all the tasks listed here above, both Topic Leader and Applicant(s) will be in close interaction in order to progress efficiently and to reorient tasks if any change or issues are encountered or foreseen.

Task 1 – Plateau phase-Concurrent Engineering

Concurrent engineering with the Topic Manager to reach the integration challenge and the detail design level, after: down-selection of piping integration, tool options and best assembly sequence/philosophy. Within this task, the Applicant(s) will receive all the information regarding geometry, constraints, preliminar assembly philosophy, piping requirements and related key characteristics and other requirements such as, but not limited to, ergonomic, safety, etc; and be in charge of the design and justification of the relevant integration aspects, as well as tools for the handling, assemblies and verification for the primary parts, the built assembly and adjoining elements integration.

The deliverable of this task will be a report of the baseline tooling compilation requirements, after assessment on costs, risks, features, Life-Cycle-Analysis, REACH, etc.

The manufacturing plan will be defined with timing and frozen inputs from product design (data-drops). During these tasks, innovative solutions for tooling related with the sensorization of the assembly tooling and piping positioning will be technologically screened.

Task 2 – Active suction system design (preliminary tool integrative aspects definition)

Concurrent engineering with the Topic Manager to reach the detail design level

Within this task, the Applicant(s) will receive the inputs, and be in charge of the design, the justification, the manufacturing and the quality control of the system piping and its key integration aspects within the adjoining elements. For that, the Topic Leader will provide the Applicant(s) with all necessary information such as geometry, integrative constraints, general tolerances and process specifications to achieve the task.

The deliverables of this task will include all 3D models and 2D drawings. Different reviews will be organized in order to keep the project on track and to validate each step before starting the next one.

Task 3 – Passive suction flap and sub-systems, and internal tooling design

Within this task, the Applicant(s) will receive the inputs, and be in charge of the design, justification, manufacturing and the quality control of the system piping and integration of the adjoining elements. For that, the Topic Leader will provide the Applicant(s) with all necessary information such as geometry, integrative constraints, general tolerances and process specifications to achieve the task.



The deliverables of this task will include all 3D models and 2D drawings. Different reviews will be organized in order to keep the project on track and to validate each step before starting the next one.

Task 4 – Tool Design and validation process (CDR) with aeronautical standards

Within this task, the applicant(s) will receive the inputs, and be in charge of the design, justification manufacturing and the quality control of the tool. For that, the Topic Leader will provide the Applicant(s) with all necessary information such as geometry, integrative constraints, general tolerances and process specifications to achieve the task.

FMEA/AMFE will be carried out to foresee and prevent any risk for the project, giving appropriate mitigation plan

FEM analysis including the assembly loads and thermal conditions of the assembly site, ie Build-up stress and deformations measurements and new manufacturing technologies for drilling templates, should be implemented during this task, and validated in a CDR maturity gate

The deliverables of this task will include a matured 3D models and 2D drawings with accessibility (maintenance and operational) assessment (AR/VR integration will be appreciated).

Different reviews will be organized in order to keep the project on track and to validate each step before starting the next one

The applicant(s) will work in close collaboration with the topic manager to validate the outcomes of the different activities in this task.

Task 5 – Manufacture, Delivery and installation of the complete tooling set

Within this task, the Applicant(s) and the Topic Leader will be in charge of the Review of the design, the justification plan, ready for manufacturing and assembly, including the verification and pre-test plan of the different elements and installation. For that, the Topic Leader will provide the Applicant(s) with all necessary information such as global aircraft Technology Readiness Level –TRL4/5- requirements.

This concerns also the specific sub-systems (connectors, harness, control and monitoring sensors ...) and their possible adaptations for the appropriate GBD FLE integration.

Different reviews will be organized in order to keep the project on track and to validate each step before starting the next one.

Along with the delivery, CoCs must be provided before starting assembly activities.

Task 6 – Assistance during assembly and functional test (GBD)

The Applicant(s) will provide the necessary on-site assistance, as requested, during the components manufacturing, assembly/verification and functional test. In addition to that, the Applicant(s) will be also in charge of the pre-testing of the different elements before delivery.

3. Major Deliverables/ Milestones and schedule (estimate)

*Type: R=Report, RM=Review Meeting, D=Data, HW=Hardware

Deliverables:			
Ref. No.	Title - Description	Type*	Due Date
D1	Assembly tools and suction system, preliminary definition	R	T0+6M
D2	Tradeoffs report (Materials, Standards, Integration...)	R	T0+9M
D3	Assembly tools and suction system definition dossiers and justification reports	R,D	T0+12M
D4	Advanced product structure and Data-drops defined	R	T0+16M

Deliverables:			
Ref. No.	Title - Description	Type*	Due Date
D5	Manufacturing and validation documents of Suction systems and Tool (LLI)	R	T0+18
D6	Tool Manufacturing, delivery and validation documents	R, D,HW	T0+24M
D7	Piping product delivery and CoC	HW,D	T0+28M
D8	Final report: Conclusions and lesson learned	R	T0+30M

Milestones (when appropriate)			
Ref. No.	Title - Description	Type*	Due Date
M1	Technology screening, materials and tradeoffs	R	T0+9M
M2	Assembly tools and suction system definition dossiers	R	T0+12M
M3	Manufacturing processes / Product Structure defined	R	T0+16M
M4	CDR	R	T0+18M
M5	Manufacturing and validation documents	R	T0+24M
M6	Assembly tool delivery	HW	T0+24M
M7	Piping product delivery and installation	HW	T0+28M
M8	Final reports, Lessons learnt and project closure	R	T0+30M

4. Special skills, Capabilities, Certification expected from the Applicant(s)

(E) – Essential; (A) – Appreciated

The CfP partner/consortium should have proven experience in air systems piping; Experience in aeronautic tools design, manufacturing and quality.

- Experience in former HLFC European or collaborative programs (A).
- Internal management of the project (with single focal-point) (E).
- CAD-CAM software license compatible with project DMU: CatiaV5R21 (E).
- An international standard quality management system (i.e. EN 9100:2009/ ISO 9001:2008/ ISO 14001:2004). (E)
- ALM technology knowledge. (A).
- Capacity to repair or modify “in-shop” the prototype manufacturing tooling for components due to manufacturing deviations. (A).
- Qualification as strategic supplier of manufacturing tooling on aeronautical elements. (A).
- Into the eco design field, the Partner shall have the capability to monitor and decrease the use of hazardous substances regarding REACH regulation (E).

The above mentioned requirements will be fixed in more details during the partner agreement phase-Negotiation Phase. This will also include the IP-process.

5. Abbreviations

ALM	Additive Layer Manufacturing
AR	Augmented Reality
CAD/CAM	Computer Aided Design / Computer Aided Manufacturing
CATIA	Computer-aided three dimensional interactive application
CDR	Critical Design Review



CoC	Certificate of Conformity
DMU	Digital Mock-up
FEM	Finite Element Model
FLE	Fixed Leading Edge
FMEA/AMFE	Failure Mode and Effect Analysis (Análisis Modal de Fallos y Efectos)
GBD	Ground Based Demonstrator
HLFC	Hybrid Laminar Flow Control
IP	Intellectual Property
ISO	International Organization for Standardization
LE	Leading Edge
LLI	Long Lead-time Items
NL	Natural Laminar
PDR	Preliminary Design Review
REACH	Registration, Evaluation, Authorization and restriction of Chemicals' regulation
TLR	Top Level Requirements
TRL	Technology Readiness Level
VR	Virtual Reality
WIPS	Wind Ice Protection System

IX. JTI-CS2-2018-CfP09-LPA-01-66: Shielding/High-lift composite thermoplastic flap manufacturing, tool design and manufacturing & process definition

Type of action (RIA/IA/CSA):		IA	
Programme Area:		LPA	
(CS2 JTP 2015) WP Ref.:		WP 1.4.4	
Indicative Funding Topic Value (in k€):		900	
Topic Leader:	SONACA	Type of Agreement:	Implementation Agreement
Duration of the action (in Months):	39	Indicative Start Date (at the earliest)²²:	Q3 2019

Topic Identification Code	Title
JTI-CS2-2018- CfP09-LPA-01-66	Shielding/High-lift composite thermoplastic flap manufacturing, tool design and manufacturing & process definition
Short description	
Development of composite thermoplastic shielding/High-lift flap out-of-autoclave manufacturing process for long range aircraft. The topic will also include the design and the manufacturing of the required tool allowing the production of the panels.	

Links to the Clean Sky 2 Programme High-level Objectives²³				
This topic is located in the demonstration area:		Advanced Laminar Flow Technologies		
The outcome of the project will mainly contribute to the following conceptual aircraft/air transport type as presented in the scene setter:		Advanced Long-range		
With expected impacts related to the Programme high-level objectives:				
Reducing CO₂ emissions	Reducing NO_x emissions	Reducing Noise emissions	Improving EU Competitiveness	Improving Mobility
<input checked="" type="checkbox"/>	<input type="checkbox"/>	<input type="checkbox"/>	<input type="checkbox"/>	<input type="checkbox"/>

²² The start date corresponds to actual start date with all legal documents in place.

²³ For further info see Chapter 1 “Introduction to the Programme Scene Setter / Objectives” with key technology themes / demonstration areas. Detailed information available in the CS2 Development Plan accessible via the Clean Sky JU Website and EC Participant Portal.

1. Background

Having laminar wing on future aircraft is an important challenge for the aeronautical industry. Those new laminar wings will reduce directly the fuel consumption of the aircraft during its mission and is therefore very interesting. In addition to the laminarity, a system is developed to control the boundary layer (HLFC – Hybrid laminar Flow Control) which is very sensitive to wing surface quality. Indeed, any defaults will go to a loss of laminarity in the area, such as steps, gaps, profile deviation but also insect impacts. By consequence a shielding device has to be designed and manufactured to protect the wings during take-off and landing phases. This shielding device also has a high-lift function.

2. Scope of work

The scope of this topic is to develop and manufacture a carbon fiber based composite thermoplastic shielding/high-lift panel(s) for a HLFC wing leading edge of a long range aircraft and to design and manufacture the different associated tools. The picture below gives an overview of what could be a shielding/High-lift panel.

The state-of-the-art for composite thermoplastic shows some major benefits to develop in-situ (out-of-autoclave) consolidation for manufacturing of such kind of parts, mainly based on manufacturing cost reduction resulting from the absence of autoclave, energy consumption reduction and improved cycle time. Associated to an in-line welding, the concept will become more innovative, allowing a greatly integrated part while increasing the delivery rate at the same time. All alternative processes showing innovation potential coupled with cost reduction and high production rate (around 15 long-range aircraft/month) should be proposed based on technico-economical evidence.

The aim of this topic is to demonstrate the feasibility of the technology for Krueger flaps structure manufacturing and to develop the process which allows building such part. An assesment of the Manufacturing Readiness Level (MRL) will be performed in parallel of the Technical Readiness Level (TRL) of the concept.

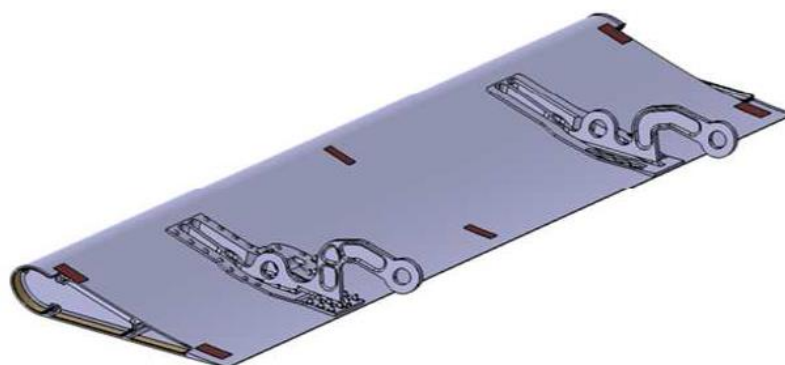

Figure 1: Schematic view of a Shielding/High-lift flap (non contractual geometry)

The work within this topic will cover:

- The process definition in a relation to a conceptual design and the support to the Topic Leader for panels design
- The design and the manufacturing of the different tools:
 - Composite thermoplastic parts manufacturing tools
 - Assembly tools for panel(s) and kinematics
 - Control tools



- Lifting tools

- The production of the thermoplastic composite parts and shielding flap
- The collaboration between the Applicant(s) and the Topic Leader during the different design, manufacturing and assembly phases.

The dimensions of the final shielding/High-lift panel(s) (quantity 3) will be around 2.5m for a chord length of about 0.4m.

The vocation of the panel(s) is for ground testing (outside of wind tunnel, even if the possibility to put the panel(s) into a wind tunnel exists).

A technico-economical analysis is to be prepared by the Applicant(s) in order to define the best process(es) to be used to build those composite thermoplastic Krueger flaps. This analysis has to take into consideration several parameters and especially the technical and economical aspects, the innovation linked to the technology and a risks analysis associated to the processes.

The analysis shall be based on in-situ consolidation with in-line welding process concept, and shall be compared to alternative concepts such as standard autoclave post-consolidation, induction welding, compression molding, overmolding possibility or any other suitable concepts.

The study shall highlight the balance between innovation, risks and cost efficiency (with a focus on the best cost regarding the global process, reducing the global lead time thanks to automation). Also, the development cost could be reduced by integration of process simulation. In the same way, a proposal to reduce quality controls is also expected via, for example, an “in-line” control of the process parameters. During the project, a final assessment and choice will be performed in collaboration with the Topic Leader and based on the Krueger flap concepts.

On the tooling side, different ways are to be studied and evaluated in order to maximise the benefits of the process such as the possibility to manufacture different panels (slight geometrical deviations from one panel to the other), to use the tool as assembly jig without huge modifications, to have an easy way to remove the mandrels,... The Applicant(s) can of course propose or integrate other innovative concept(s) to the previous list.

The toolings and the manufacturing process shall be done in a way such that the technical and economical analysis concludes that they are suitable for the present application but also for the future development of such shielding/High-lift devices and serial production. The Applicant(s) could also propose a way to recycle the materials or to have a “greener” process.

The first inputs will be provided by the Topic Leader such as the first geometrical information, tolerances, expected quality level or other requirements. The panels will have to be bird impact resistant, low weight and low cost (the prioritisation of those criterias will be defined at the beginning of the project by the Topic Leader). The Applicant(s) is encouraged to propose concepts in line with the proposed processes to the Topic Leader. The Topic Leader will select the best concept to develop in order to meet the project requirements.

The Applicant(s) will be responsible for the process development in close collaboration with the Topic Leader in order, for the Topic Leader, to design the shielding panels in accordance with the developed process requirements. During this development phase, the Applicant(s) will have to demonstrate that the properties (material integrity, healthness and mechanical performances) are met.

The Applicant(s) will also be responsible for the tools specification, definition, design and their manufacturing, and will deliver them in accordance with the planning and the tooling quality standard (technical justification, control report). The objectives for the toolings will be low cost, low weight durability (or reparability/replaceability) and will be defined at the beginning of the project by the



Topic Leader. During the assembly phase, the Applicant(s) will be in charge of any assistance required by the Topic Leader.

The scope of this topic will be divided in 6 main tasks summarized in the following table and described below. A proposed planning is given right after.

Tasks		
Ref. No.	Title - Description	Due Date
T1	Support during components design and manufacturing	T0 + 32M
T2	Technico-economic analysis	T0 + 6M
T3	Manufacturing process development and validation, material property and healthness assessment	T0 + 26M
T4	Shielding/High-lift tools specification, design and manufacturing for parts production, assembly, lifting, controls	T0 + 32M
T5	Composite thermoplastic parts and shielding flap production	T0 + 38M
T6	Support during assembly phase	T0 + 39M

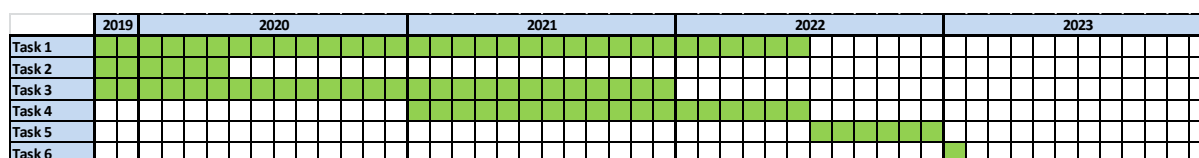

Figure 4: Proposed planning

During all the tasks listed here above, both Topic Leader and Applicant(s) will be in close interaction in order to progress efficiently and to reorganize the work if any change or issue is encountered. For this, a risk register and mitigations plans are to be used and kept up-to-date.

Task 1 – Support during components design and manufacturing

The Applicant(s) and the Topic Leader will be in close collaboration for the design of the shielding/high-lift flap and the process development in order to have parts designed in line with the process requirements. The detail design of the different components remains under the responsibility of the Topic Leader during the whole project.

Task 2 – Technico-economic analysis

Within this task, the Applicant(s) will be in charge, in collaboration with the Topic Leader, to perform a technico-economic analysis (trade-off) of the different manufacturing solutions and concepts. The assessment will take into considerations the different technical and economical aspects of each technology, list and evaluate all the risks, advantages and disadvantages linked to them with a balance regarding the innovative level.

The deliverables of the task will be a report presenting the different aspects and a matrix of assesment.

Task 3 – Manufacturing process development and validation, material property and healthness assessment

Within this task, the Applicant(s) will be in charge, in collaboration with the Topic Leader (within Task 1), to develop the manufacturing process in order to built the panel(s) within Task 5. The Applicant(s) will also have to assess material integrity, healthness and performances. Both, out-of-autoclave lay-up and welding process shall be validated. Those validations will be performed via micrography, physico-chemical analysis and some mechanical tests. This task aims to reach a certain MRL and TRL and to propose the route to improve those maturity levels (up to aircraft certification).



The deliverables of this task shall include development plan, process instructions, test specifications and test result reports.

Different reviews will be organized in order to keep the project on track and to validate each step before starting the next one.

Task 4 – Shielding/High-lift tools specification, design and manufacturing for parts production, assembly, lifting, controls

Within this task, the Applicant(s) will be in charge of the specification, the definition, the design, the justification, the manufacturing and the quality control of the shielding/High-lift panel tools including:

- Tools for thermoplastic composite parts manufacturing
- Assembly tools
- Auxiliary tools such as lifting, handling tools, controls (ie verification of produced parts)

For that, the Topic Leader will provide the Applicant with all necessary information such as shielding flap geometry, panel tolerances. The process requirements will come from the Task 3 and will be discussed between the Topic Leader and the Applicant(s). The tools will be designed in order to ease the manufacturing, the handling but also in a low cost perspective.

The deliverables of this task shall include all 3D models and 2D drawings of the tools, the manufactured tools with their justification and control reports, and delivery QA acceptance folder.

Different reviews will be organized in order to keep the project on track and to validate each step before starting the next one.

Task 5 – Composite thermoplastic parts and shielding flap production

Within this task, the Applicant(s) will be responsible for the manufacturing of the different composite thermoplastic parts entering into the flap definition and based on task 3 process definition. The produced parts shall be in accordance with the design definition provided by the Topic Leader (and defined in collaboration with the Applicant(s) within Task 4). The parts will have to be fully inspected after manufacturing (NDT, dimensional). A minimum of 3 flaps will have to be produced (2 for the GBD and 1 as demonstrator/FPQ). The fittings and other metallic components will be provided by the Topic Leader.

The deliverables for this task shall include the different produced flaps with their manufacturing reports and quality checks reports.

Different reviews will be organized in order to keep the project on track and to validate each step before starting the next one.

Task 6 – Support during assembly phase

The Applicant(s) will provide all required support such as local adaptations of the tools or the composite thermoplastic parts or repairs to the Topic Leader during the final assembly phases of the Krueger flaps during the use of the assembly tools provided by the Applicant(s). This support will be done on request by the Applicant(s).

3. Major Deliverables/ Milestones and schedule (estimate)

*Type: R=Report, RM=Review Meeting, D=Data, HW=Hardware

Deliverables			
Ref. No.	Title - Description	Type*	Due Date
D2.1	Techno-economic analysis, material and process trade-off and selection	R	T0 + 6M
D3.1	Process flow chart and its relation with conceptual part/assembly design	R	T0 + 18M

Deliverables			
Ref. No.	Title - Description	Type*	Due Date
D3.2	Material and process development plans for MRL and TRL maturity and improvement	R	T0 + 26M
D3.3	Risks analysis and mitigations plan	R	T0 + 26M
D3.4	Process instructions	R	T0 + 26M
D3.5	Manufacturing plan including tooling plan	R	T0 + 26M
D3.6	Tests specifications	R	T0 + 26M
D3.7	Tests results reports	R/D	T0 + 26M
D4.1	Shielding/High-lift panel(s) tools specification and definition	R/D	T0 + 20M
D4.2	Shielding/High-lift panel(s) tools definition dossiers and justification reports	R/D	T0 + 32M
D4.3	Shielding/High-lift panel(s) tools and their manufacturing and quality reports	R/HW	T0 + 32M
D4.4	Assembly tools definition dossiers and justification reports	R/D	T0 + 32M
D4.5	Assembly tools and their manufacturing and quality reports	R/HW	T0 + 32M
D4.6	Lifting and auxiliary tools definition dossiers and justification reports	R/D	T0 + 32M
D4.7	Lifting and auxiliary tools and their manufacturing and quality reports	R/HW	T0 + 32M
D5.1	Final composite thermoplastic parts (2 parts for GBD, 1 part as demonstrator/FPQ)	HW	T0 + 38M
D5.2	Manufacturing and quality check reports	R	T0 + 38M

Milestones (when appropriate)			
Ref. No.	Title - Description	Type*	Due Date
M1	Kick-off meeting	RM	T0
M2	Process validation report and final choice	R/RM	T0 + 6M
M3	Composite thermoplastic flap concept selection	RM	T0 + 10M
M4	Shielding/High-lift panel(s) tools PDR	RM	T0 + 17M
M5	Assembly tools PDR	RM	T0 + 17M
M6	Lifting and auxiliary tools PDR	RM	T0 + 17M
M7	Composite thermoplastic flap PDR	RM	T0 + 18M
M8	Long Lead Item procurement gate	RM	T0 + 18M
M9	Shielding/High-lift panel(s) tools CDR	RM	T0 + 24M
M10	Assembly tools CDR	RM	T0 + 24M
M11	Lifting and auxiliary tools CDR	RM	T0 + 24M
M12	Composite thermoplastic flap CDR	RM	T0 + 26M
M13	Manufacturing Readiness Review	RM	T0 + 30M
M14	Shielding/High-lift panel(s) tools Delivery	RM	T0 + 32M
M15	Assembly tools Delivery	RM	T0 + 32M
M16	Lifting and auxiliary tools Delivery	RM	T0 + 32M
M17	Final composite thermoplastic flap delivery	RM	T0 + 39M



4. Special skills, Capabilities, Certification expected from the Applicant(s)

- The Applicant(s) must have proven experience in composite thermoplastic processes and parts development and specifically in in-situ consolidation process but also in welding.
- The Applicant(s) must have proven experience in tools design and manufacturing for composite thermoplastic process and for assembly process.
- The Applicant(s) must have experience in inspections and testing.
- Experience in aeronautic tools design, manufacturing and quality would be appreciated.
- Experience in former HLFC European or collaborative programs would be highly appreciated.
- An international standard quality management system would be appreciated.

5. Abbreviations

CDR	Critical Design Review
FPQ	First Part Qualification
GBD	Ground Based Demonstrator
HLFC	Hybrid Laminar Flow Control
MRL	Manufacturing Readiness Level
NDT	Non Destructural Test
PAEK	PolyArylEtherKetone
PDR	Preliminary Design Review
PEEK	PolyEtherEtherKetone
PEKK	PolyEtherKetoneKetone
QA	Quality Assurance
TRL	Technical Readiness Level

X. JTI-CS2-2018-CfP09-LPA-01-67: UHBR Installed Advanced Nacelle Optimisation and Evaluation Close Coupled to Wing

Type of action (RIA/IA/CSA):		RIA	
Programme Area:		LPA	
(CS2 JTP 2015) WP Ref.:		WP 1.5.2	
Indicative Funding Topic Value (in k€):		3400	
Topic Leader:	Rolls-Royce	Type of Agreement:	Implementation Agreement
Duration of the action (in Months):	36	Indicative Start Date (at the earliest)²⁴:	Q3 2019

Topic Identification Code	Title
JTI-CS2-2018-CfP09-LPA-01-67	UHBR Installed Advanced Nacelle Optimisation and Evaluation Close Coupled to Wing
Short description	
UHBR engines require novel advanced nacelles, close coupled to the wing, for an optimum installed low drag powerplant, outside the current design experience. The Project objective is to apply multi-objective optimisation techniques to advanced 3-D nacelle systems in combination with the installed flow field. This requires utilising of the latest CFD techniques to predict installed nacelle thrust & drag enhancements, to define novel nacelle candidate designs for test. Wind Tunnel Testing of installed UHBR cycle powered nacelles featuring a low pressure ratio fan and novel power systems to accurately simulate representative exhaust jets is required; - validating the predicted benefit(s), using novel measurement techniques.	

Links to the Clean Sky 2 Programme High-level Objectives²⁵				
This topic is located in the demonstration area:		Advanced Engine/Airframe Architectures		
The outcome of the project will mainly contribute to the following conceptual aircraft/air transport type as presented in the scene setter:		Advanced Long-range Advanced Short/Medium-range		
With expected impacts related to the Programme high-level objectives:				
Reducing CO₂ emissions	Reducing NO_x emissions	Reducing Noise emissions	Improving EU Competitiveness	Improving Mobility
<input checked="" type="checkbox"/>	<input type="checkbox"/>	<input type="checkbox"/>	<input type="checkbox"/>	<input type="checkbox"/>

²⁴ The start date corresponds to actual start date with all legal documents in place.

²⁵ For further info see Chapter 1 "Introduction to the Programme Scene Setter / Objectives" with key technology themes / demonstration areas. Detailed information available in the CS2 Development Plan accessible via the Clean Sky JU Website and EC Participant Portal.



1. Background

Reducing fuel burn and CO₂ emissions to meet the future EU ACARE and Flightpath 2050 goals is a major factor in the design of the UltraFan® next generation engines. Adoption of an UltraFan® low specific thrust engine cycle to maximise propulsive efficiency leads to an increase in engine fan diameter and a consequential increase in nacelle size & weight with current design rules.

To fully enable the potential benefits of compact UltraFan® advanced nacelles it will be necessary to enhance the ability to efficiently install the nacelle closer coupled with the wing, for structural efficiency and weight saving opportunities. To maximise the benefits for larger UHBR UltraFan® engines from a ground clearance and structural perspective will require novel installation positions. These configurations are outside current industry experience. The close coupled installations will result in a significant three dimensional pressure field over the aft nacelle, which is not accounted for in current nacelle design rules. This provides a novel design opportunity to 3-D optimise the aft nacelle design for these new close coupled installed positions to further enhance the fuel burn gains that can be realised from the more efficient engine cycle. Current standard aft nacelle design rules do not cover this novel design region for UHBR UltraFan® engine concepts. Adoption of a novel design philosophy for the aft nacelle for optimum installed cruise mission performance for the new novel UHBR configurations will provide additional opportunities to enhance installed UltraFan® engine performance.

Latest advances in automated multipoint, multi-objective numerical design optimisation, combined with latest CFD installed drag and thrust prediction techniques, and advanced parametric geometry methods will need to be brought together to enable these novel designs for installed 3-D aft cowls, including pylons. The outcome will be to develop new design rules for mission optimised aft nacelles for the latest UHBR UltraFan® engines. Optimisation for a full cruise mission, over a range of power settings, will enable optimum nacelle pressure distributions and exhaust shock topographies to be identified both to minimise drag and maximise installed performance, as well as the overall combined effect, for a range of installed nacelle locations. Identifying novel optimum design concepts which are able to deliver performance benefits over the full range of cruise mission operating conditions are required. Understanding of how the novel nacelle configurations and installed pressure field influence engine cycle matching and back pressure on engine nacelle ventilation systems in the cruise phase will be important for powerplant system level understanding. Detailed parametric design studies of the novel installed design space will enable enhanced understanding of the drag and thrust behaviour of nacelles in a flight regime where complex shock behaviour occurs. To calibrate the CFD methods for these novel nacelle designs, and to verify the performance benefits, a wind tunnel test will be required featuring novel powered nacelles which accurately model the engine exhaust flow field. The enhanced understanding of advanced UHBR UltraFan® aft nacelles and development of new verified design rules for 3D non-symmetric nacelles will enhance the potential performance gains for UHBR UltraFan® engines.

This programme of work shall include an installed configuration representative of the Ultrafan® FTD to predict the influence of the wing pressure field on the aft nacelle, and how this can be modified by different installation positions. The timing of this proposed programme is aligned with the UltraFan® FTD programme and will aid understanding and interpretation of test results. The flight test campaign of the UltraFan® demonstrator will provide a TRL6 opportunity to investigate the influence of the asymmetric pressure field from the installation on the aft nacelle and exhaust; targeted by this proposed design approach.

In addition to the cruise design point it will be important to conduct CFD studies, which consider the nacelle performance under Take off configurations to confirm the new designs can achieve acceptable

aerodynamic performance under all operating conditions. Again the UltraFan® flight demonstrator will provide an opportunity to verify these findings.

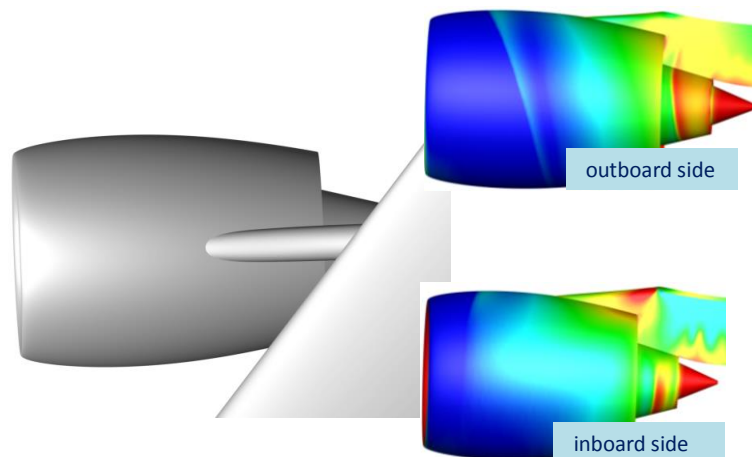

Influence of 3-D Flow Field on Installed Aft Nacelle

2. Scope of work

The aim of this programme is thus to apply the latest multipoint, multi-objective design optimisation techniques to enable new design opportunities for novel advanced aft nacelles close coupled to wing for optimum installed powerplant performance, outside current design experience for UltraFan® applications. 3-D optimised aft nacelle concepts should be developed for long range applications for Mach 0.85, and Mach 0.80 for medium range applications. The optimum designs from the multi-objective design space exploration will be down selected for verification wind tunnel testing. The wind tunnel test will require novel powered nacelle simulators which accurately represent the optimised aft nacelle geometry and jet characteristics, and novel flow measurement techniques. This programme of work requests significant innovation in three key areas, multi-objective design applied to 3-D installed aft nacelles, and novel measurement techniques. CFD and methods chosen for design and analysis shall be mutually agreed with topic manager; either commercially available codes, or agreed alternative.

Testing of three to five nacelle geometries, each one investigated over a matrix of installed locations, (up to 10), is anticipated utilising proven installed testing techniques on a powered half aircraft model. Powered nacelles will require pre-calibration in a Mach Simulation Facility. To ensure the installed performance opportunities are fully understood and to maximise the potential for CFD validation, innovative high fidelity measurement of the nacelle and exhaust surface pressure field & shock topography is required. Appropriate static pressure instrumentation shall be included on the nacelles, wing and pylon to complement, calibrate and verify the novel measurement techniques.

Wind tunnel test verification will require testing at transonic speeds, on a half aircraft model (of approximately 1/20 scale) long range twin engined configuration with a drag rise M_n in excess of $M=0.82$, featuring powered UHBR nacelles, over a range of cruise flight speeds from $M=0.3$ to 0.90. An aircraft model based on the NASA 'open source' Common Research Model (CRM) is required; unless a suitable alternative can be proposed. The tunnel shall be equipped with a thrust balance to measure drag to accepted 'industry standards'. Provision of Kulites on the aircraft fuselage and tunnel wall to monitor acoustic characteristics would be a significant additional advantage to enable installed acoustic trends to also be monitored, and proposals are requested.

To accurately reproduce the exhaust geometry and jet characteristics of a UHBR engine a novel hydraulic or electric powered engine simulator, with a low speed fan greater than 150 mm is required (to achieve cruise fan nozzle pressure ratios representative of a UHBR cycle).

To provide a high fidelity database for method validation development and application of novel innovative measurement techniques need to be applied. It is envisaged these would include Dynamic PSP {pressure sensitive paint} for surface pressures, and Schlieren techniques for shock field evaluation. A novel innovative challenge will be enabling optical visualisation and recording techniques. This is required to enable all views of the nacelle and exhaust surfaces to be measured. Other suitable innovative techniques which can be developed to sufficient maturity ahead of the main test phase can be proposed.

A programme to enable novel mission-optimised installed non-symmetric nacelles will provide:

- Validated aerodynamic design rules for close coupled 3-D optimised advanced nacelles.
- Demonstrate the benefits of a 3-D non-symmetric nacelle design approach, using novel multipoint multi-objective optimisation techniques, for novel UltraFan® installation locations
- Evaluation of the advanced aft nacelle performance enhancement, and influences of installed pressure field on engine matching.
- Transonic wind tunnel test, featuring novel UHBR simulators, to validate novel nacelle design solutions and installation effects, for a range of nacelle configurations and locations.
- Adoption of novel measurement techniques for nacelle pressure and shock field, to enhance understanding of flow physics for CFD validation.
- CFD Evaluation of changes in nacelle and exhaust behaviour at take off conditions.

Design and Verification of novel advanced nacelles close coupled to wing for optimum installed performance for UltraFan® engine(s):

Tasks		
Ref. No.	Title - Description	Due Date
1	Agree nacelle design envelope, and installation positions	T0 + 6 months
2	Definition and agreement of thrust and drag accounting procedures for CFD and model test	T0 + 12 months
3	Down selection of novel powered nacelle simulator	T0 + 12 months
4	Down select of novel pressure and shock field measuring techniques and development plan	T0 + 12 months
5	Multipoint design and Optimisation of installed aft nacelles	T0 + 15 months
6	Design and manufacture wind tunnel models, incorporating advanced instrumentation. Complete de-risk phase of simulator and innovative instrumentation concepts	T0 + 22 months
7	Conduct Transonic wind tunnel test to provide validation database for novel installed nacelle configurations.	T0 + 28 months
8	Complete wind tunnel data post processing	T0 + 32 months
9	Installed Validation of CFD for nacelle methods.	T0 + 36 months

Task 1

- Review of design trends for novel installed nacelles to downselect and propose innovative design space matrix and define range of options for future study (Task 5).
- Agree innovative nacelle design proposals, nacelle investigation matrix with topic manager.

Task 2

- Review industry standard thrust and drag book-keeping approaches and propose methodology for both CFD and wind tunnel test verification.

Task 3

- Study to determine optimum UltraFan® powered simulator featuring a low pressure ratio fan and exhaust flow field configuration.
- Define development and de-risking plan for verification and calibration of simulator ahead of main wind tunnel test phase.

Task 4

- Study to down select enhanced and novel measurement techniques for transonic nacelle and exhaust aerodynamic flow measurement to enhance understanding for CFD method verification.
- Definition of development and verification requirements to productionise techniques ahead of main wind tunnel test phase.

Task 5

- Application of latest multipoint optimisation techniques, (CFD, geometry tools), and robust thrust-drag book-keeping approaches to identify optimum installed nacelle configurations for novel UltraFan® installed nacelle design.
- Construct cycle model for UHBR engine concept to provide CFD boundary conditions and model enable cycle re-matching to account for installed effects.
- Determine optimum nacelle configurations for UltraFan® installations for Mn 0.85 and Mn 0.80 cruise. Down select optimum configurations for test.

Task 6

- Design and manufacture wind tunnel models, incorporating advanced instrumentation to verify novel UltraFan® Installed nacelle designs.
- Complete test verification de-risk phase for UltraFan® powered simulator.
- Complete innovative instrumentation de-risk phase.
- Define data processing routines and data display requirements, analysis verification test cases.

Task 7

- Conduct transonic wind tunnel test to provide validation database of novel UltraFan® Installed nacelle designs.

Task 8

- Post process wind tunnel test results.
- Report wind tunnel test results

Task 9

- CFD study to confirm acceptability of novel UltraFan® Installed nacelle designs under take off conditions.
- Validation of CFD novel nacelle installation prediction and design optimisation process against wind tunnel data
- Produce design guidelines for novel UltraFan® Installed nacelle designs.
- Final report of programme findings

3. Major Deliverables/ Milestones and schedule (estimate)

*Types: P=Plan, R=Report, D=Data, HW=Hardware, Rw=Review

Deliverables			
Ref. No.	Title - Description	Type*	Due Date
D1	Work Plan for all tasks	P	T0 +2 months
D2	Nacelle installed design envelope matrix definition	R	T0 + 6 months
D3	Thrust and Drag 'Book-keeping' methodology defined for CFD and test	R	T0 + 12 months
D4	Wind tunnel powered nacelle and novel measurement technique evaluation summary and development plan	R	T0 + 12 months
D5	Nacelle geometry definition for wind tunnel test.	CADD model + R	T0 + 18 months
D6	Status summary on engine simulator and novel instrumentation development	R + D	T0 + 22 months
D6	Wind tunnel model manufacture and measurement system verification.	HW	T0 + 24 months
D7	Novel UltraFan® Installed nacelle designs CFD summary	D	T0 + 24 months
D8	Wind tunnel test and pre-test CFD prediction	R + D	T0 + 30 months
D9	Post processing of wind tunnel results	R	T0 + 32 months
D10	Novel UltraFan® Installed nacelle design rules	R	T0 + 36 months

Milestones (when appropriate)			
Ref. No.	Title - Description	Type*	Due Date
M1	Work Plan agreed	R	T0 + 2 months
M2	Novel nacelle study matrix agreed	Rw	T0 + 6 months
M3	Novel nacelle installation geometry down select	Rw	T0 + 18 months
M4	Model and instrumentation definition for manufacture. Simulator and instrumentation de-risk testing complete.	Rw	T0 + 20 months
M5	Wind tunnel test model manufacture complete	HW	T0 + 24 months
M6	Wind tunnel test complete	D	T0 + 30 months
M7	Post test CFD validation complete	R	T0 + 36 months

4. Special skills, Capabilities, Certification expected from the Applicant(s)

Generic requirements include:

- Have substantial technical knowledge in the domain of the proposed tasks
- Demonstrated expertise in project participation, international cooperation, project and quality management
- Proven achievement record showing knowledge is recognised in the scientific community

This specific package of work will require expertise in:

- Established track-record in the analysis and testing of installed aerodynamic performance of large civil aero-engines with separate-jet exhausts
- Proven track record, and demonstrated expertise, in the application of multipoint multi-objective design optimisation, and design space exploration to underwing high bypass ratio turbofan nacelles (intakes, nacelles, exhaust and pylons), for large civil jet engines.

- Understanding of current UHBR nacelle design objectives and novel design opportunities.
- Proven ability to rapidly generate aerodynamic quality parametric 3-D nacelles, including an exhaust geometry; and CADD surfaces suitable for manufacture.
- Proven demonstrated ability to conduct installed nacelle CFD analysis using methods that are already validated against industry standard test cases. Established track-record in the analysis of installed aerodynamic performance of large civil aero-engines with separate-jet exhausts.
- Demonstrated capability to apply robust thrust-drag book-keeping approaches to evaluate the aerodynamic behaviour of nacelle, intake, and exhaust components for close-coupled engine-airframe architectures.
- Capability to design and analyse non-axisymmetric nacelle configurations for large turbofans for close-coupled underwing civil aero-engine installations
- Proven ability to design separate-jet exhaust systems for Ultra-High-Bypass Ratio UltraFan® civil aero-engine configurations.
- Proven ability to conduct Engine Cycle modelling to define a UHBR engine cycle and model re-matching effects due to installation effects.
- Proven ability to conduct industry standard transonic wind tunnel testing (>2.0 m working sectionwidth), wing and half aircraft model with a semi span greater than 1.4 m with hydraulic or electric powered nacelle simulators, with a fan diameter greater than 150 mm diameter (featuring a low speed fan design) (tunnels with working sections between 1.2m and 2.0m may be considered, with corresponding model scale adjustment, if appropriate/relevant experience can be demonstrated in obtaining high quality data).
- Experience to develop and apply novel wind tunnel measurement techniques to enhance the understanding of installed nacelle drag behaviour.
- A proven established capability of conducting powered installed nacelle drag testing, and powered nacelle thrust calibration using a ‘Mach simulation’ facility is required.
- Ability to deliver a novel UHBR hydraulic or electrical powered simulator with a representative fan, greater than 150 mm (alternative propulsion configurations may be considered, provided the aft nacelle and exhaust jet can be appropriately simulated).
- Expertise to develop and apply novel wind tunnel measurement techniques to enhance the understanding of installed nacelle drag and thrust behaviour, with focus on surface pressure distributions and shock topography. Demonstrated experience in applying Dynamic PSP {pressure sensitive paint} for surface pressures, and Schlieren techniques for shock field evaluation is required. Capability to develop novel optical recording techniques to enable all views of the nacelle and exhaust surfaces to be measured are desirable.
- Experience of conducting acoustic measurements with the transonic tunnel would be desired.

5. Abbreviations

CFD	Computational Fluid Dynamics
Mn	Mach Number
CADD	Computer Aided Design
PSP	Pressure Sensitive Paint
CRM	NASA ‘open source’ Common Research Model.
UHBR	Ultra High Bypass Ratio (Engine)
TRL6	Technical Rediness Level 6 – full system level demonstartion in representative environment

XI. JTI-CS2-2018-CfP09-LPA-01-68: Non-Intrusive Flow Field Measurement within a UHBR Intake

Type of action (RIA/IA/CSA):		RIA	
Programme Area:		LPA	
(CS2 JTP 2015) WP Ref.:		WP 1.5.2	
Indicative Funding Topic Value (in k€):		2250	
Topic Leader:	Rolls-Royce	Type of Agreement:	Implementation Agreement
Duration of the action (in Months):	36	Indicative Start Date (at the earliest)²⁶:	Q3 2019

Topic Identification Code	Title
JTI-CS2-2018-CfP09-LPA-01-68	Non-Intrusive Flow Field Measurement within a UHBR Intake
Short description	
Development and experimental verification of non-intrusive measuring techniques suitable for measuring complex flow field(s), both temporally and spatially within a model scale turbofan intake system, for use in large low speed wind tunnels. This capability is required to enable detail understanding of intake fan aerodynamic, aero mechanical and acoustic physics within a future UHBR engine with a short intake. The Project objective is to demonstrate the capability of such a measurement system to map the intake flow field just upstream of the fan; and to post process the data, to rapidly derive intake compatibility metrics.	

Links to the Clean Sky 2 Programme High-level Objectives²⁷				
This topic is located in the demonstration area:		Advanced Engine/Airframe Architectures		
The outcome of the project will mainly contribute to the following conceptual aircraft/air transport type as presented in the scene setter:		Advanced Long-range Ultra-advanced Long-range Advanced Short/Medium-range Ultra-advanced Short/Medium-range		
With expected impacts related to the Programme high-level objectives:				
Reducing CO₂ emissions	Reducing NO_x emissions	Reducing Noise emissions	Improving EU Competitiveness	Improving Mobility
<input checked="" type="checkbox"/>	<input type="checkbox"/>	<input type="checkbox"/>	<input type="checkbox"/>	<input type="checkbox"/>

²⁶ The start date corresponds to actual start date with all legal documents in place.

²⁷ For further info see Chapter 1 “Introduction to the Programme Scene Setter / Objectives” with key technology themes / demonstration areas. Detailed information available in the CS2 Development Plan accessible via the Clean Sky JU Website and EC Participant Portal.



1. Background

Reducing fuel burn, CO₂ emissions, and noise to meet the future EU ACARE and Flightpath 2050 goals is a major factor in the design of the UltraFan® next generation engines. Adoption of an UltraFan® low specific thrust engine cycle to maximise propulsive efficiency leads to an increase in engine fan diameter and a consequential increase in nacelle size & weight with current design rules.

To minimise nacelle size and drag, novel short intake concepts are under consideration, a potential downside of which is additional complexity of the flow field entering the fan system, under ground crosswind and high angle of attack conditions in flight, and key noise operating points during take-off. It is essential that this complex flow field is understood, for a coupled intake and fan system, to enable optimum design solutions to be developed. This will require wind tunnel test of scale models of UltraFan® intakes with a rotating fan assembly for validation. The current industry approach for intake compatibility testing using an array of pressure rakes at the fan-plane, provides only limited spatial resolution and is very intrusive, which risks significantly modifying the flow field and fan response; and is unsuitable for acoustic testing.

To understand the complex flow physics within such a coupled intake-fan system, innovative novel non-intrusive measurement techniques are required.

The ability to obtain high fidelity measurements on a coupled intake rig will enable key physics of intake flow separation mechanisms to be measured and understood for the Ultrafan® full scale engine demonstration test phase. This will aid methods calibration for test prediction for the full scale testing and enable direct comparisons with measurements from Ultrafan® demonstrator ground and flight tests.

The primary aim of the programme should be to develop a novel innovative measurement technique, whereby its capabilities reflect the future need to be suitable for deployment efficiently in large commercial high productivity wind tunnels with working sections up to 8 m. This requirement should be accounted when defining instrumentation equipment positions. The ability to be compatible with acoustic test configurations would be an advantage.

The proposed measurement approach will need to be combined with aligned novel innovative data post processing and analysis techniques appropriate to characterise the resulting complex flow fields into intake fan compatibility engineering parameters to provide detail understanding of the flow field behaviour. This will require the application of innovative pressure field reconstruction techniques and high order analysis methods. A parallel CFD programme to develop a detail understanding of the flow field instrumentation requirements, and provide data to develop innovative 'high order' data analysis and pressure field reconstruction post processing will also be required.

The aim of this programme is to thus develop, and de-risk a novel non-intrusive measurement technique to provide high resolution flow field data in a coupled UltraFan® intake and fan model scale rig, mounted in a large commercial wind tunnel. The optimum techniques will be down selected and require validation by representative testing in a suitable facility.

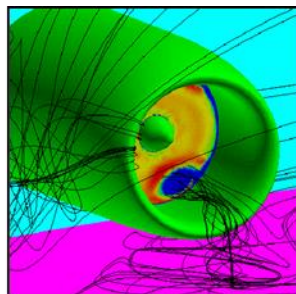

Typical intake measurement rake system

- Intrusive
- Low spatial fidelity

Requirement to map highly complex flow behaviour

- High resolution
- Non - intrusive

Project objective – enable non intrusive high fidelity intake flow field measurement ahead of fan rotor

2. Scope of work

To understand the complex flow physics within such a coupled intake-fan system, innovative novel measurement approaches are required. The first requirement is that any technique must be non-intrusive, in terms of impact on the aerodynamics of the intake or the fan. The technique deployed must be suitable for use with conventional intakes as well as short high bypass ratio UltraFan® intake systems, including the fan centre body spinner.

The technique must be able to map the full annulus flow field close to the fan face, at specified planes ahead of the fan, perpendicular to the primary flow direction, with the fan spinner present. The ability to also map flow in axial planes along the intake may also be advantageous, if compatible with the chosen technique.

Since the flow field is expected to be unsteady in some operating conditions, the technique must provide synchronous measurements of the full flow field at a single point in time, and ideally will do so at a frequency high enough to adequately resolve that unsteadiness for the purposes of understanding fan response. This will need to be combined with novel data post processing and analysis techniques appropriate to characterise the resulting complex flow fields.

It is envisaged that an optical approach such as PIV will be the most suited to the requirement described above, but other novel techniques can be included in the down selection if considered appropriately mature.

The techniques proposed must be able to map the full fan face flow field under intake off design conditions such as:-

- Ground crosswind in freestream velocities from 0 to 25 m/s with a static ground plane modelled at representative height
- High Incidence operation, at fixed intervals, between 10 & 40 degrees at $Mn = 0.15$ to 0.30

The main flow conditions of interest at the fan plane will be mid to high power conditions with average



Mn in the 0.3 to 0.55 range. However the chosen techniques must be suitable for measuring the coupled intake fan flow field at off design conditions where significant intake separation is present, and low Mn or even reversed flow is present.

The primary aim of the programme should be to develop a measurement technique, whereby its capabilities have been proven for suitable for future deployment efficiently in large commercial high productivity wind tunnels with working sections up to 8 m. The ability to be compatible with acoustic test configurations would be an advantage. The choice of measuring equipment and location must consider the need to be suitable for future deployment in large, up to 8m, test facilities.

The programme of activity should down select suitable measurement equipment and mounting configurations to enable future utilisation in wind tunnels of up to 8 m working section. It will be necessary to ensure that the chosen equipment locations and mountings are non-intrusive with respect to the intake system flow field

To provide accurate mapping of the intake circumferential flow field a spatial resolution within 4 by 4 mm is required. It is envisaged the production technique will be utilised on an intake system with a fan face diameter in the 325 to 400 mm range. Synchronous data measurements over the full annulus are a primary requirement. Proposals which meet this primary objective are invited. An acquisition frequency for the instantaneous vector field in the range between 4 and 15 Hz is a primary requirement. To enhance spatial resolution, options to use multiple cameras, high resolution cameras, or traversing options would be invited.

To investigate time variant flow field phenomena a temporal resolution in the order of up to 200Hz would be desired. Proposals which meet the defined spatial resolution, and can achieve enhanced measurement frequency requirement over the full flow annulus and/or specific regions of interest are invited. Proposals which can enable higher frequency flow field mapping of either the full annulus or local areas would be considered.

If optical techniques are selected, part of the development of the measurement technique will be the selection of suitable equipment to measure data at the required temporal and spatial resolution, and suitable flow seeding, to operate under both X-wind and high incidence conditions within large wind tunnels (up to 8 m working section). The design of the optical arrangement should reflect the future use requirements, and an optical check out test conducted to confirm this. It may also be necessary for the model intake to feature optical access; e.g. for the laser light sheet in a PIV setup. In this case the scope of work should also include the development of such an intake, whilst maintaining the necessary aerodynamic and mechanical capabilities, and provision for conventional surface-mounted pressure instrumentation as will be described below. The potential issues associated with surface contamination of the intake and fan system with 'seeding fluid' shall be explored. Optical distortion corrections will also need to be accounted, and correction algorithms developed and validated.

To develop the measurement technique to an appropriate level of maturity a phased development approach is considered necessary, requiring conducting proof of concept testing in a suitable environment with a powered flowing intake and external freestream flow field. It would be considered acceptable to develop the measurement technique on a smaller model in the 250 to 350 mm fan face diameter range, with a flowing intake system, in a wind tunnel of approx. 2.4 to 3 m working section, or larger. Inclusion of a rotating fan assembly would be considered an advantage for de-risking and demonstrating the coupled measurement capability.



The verification facility shall be capable of simulating representative crosswind with a ground plane up to 25 m/s, and high angle of attack conditions with the flight speeds in the $M=0.12$ to 0.30 range. The mounting arrangement for the measuring equipment for use in large commercial wind tunnel of up to 8 m working section should also be defined as part of the programme deliverables.

To ensure that the flow field measurements can be converted into total and static pressure, and swirl and angularity intake compatibility parameters it is envisaged that an array of pressure instrumentation will be required in addition to the optical technique. An array of approximately 200 static tapings would be considered appropriate. The exact requirements shall be determined during the development of the proposed novel technique. This may also include provision surface static dynamic measurement capability up to 10 KHz, (approx. 20 off.) The exact number and positioning of the pressure instrumentation will be linked to the ‘pressure reconstruction’ techniques proposed for post processing.

To ensure that flow field data collected can be efficiently post processed, into intake fan compatibility engineering parameters for total, static pressure and swirl distortion metrics, post processing algorithms will be required, appropriate to the measurement technique chosen. This will require application of ‘pressure field reconstruction techniques’ from the measured velocity field and appropriate ‘high order’ data analysis methods, proven applicable for rapidly post processing complex jet engine intake flow fields. Use of high order numerical analysis methods, such as POD and extreme value theory, are considered acceptable.

It is considered that this programme should include a parallel activity of CFD simulation of the expected flow field within the proof of concept demonstrator to assist with the definition of the array of pressure instrumentation, and provide flow field information to be used to validate the proposed post processing data algorithms ahead of the test phase. The CFD topic should utilise either a mutually agreed commercially available code or agreed alternative.

A programme to enable novel non-intrusive full annulus flow field within a short UltraFan® intake ahead of the rotor will require:

- Down select of potential measurement techniques and instrumentation requirements, to provide required flow field measurement.
- Define and conduct a series of validation tests in a representative test environment (wind tunnel approx. >2.4 to 3m, or larger) to achieve required technical maturity for deployment.
- Development of post processing algorithms to provide rapid interpretation of complex flow field and convert data into intake compatibility metrics of interest.
- CFD simulation of coupled intake system to assist in defining suitable instrumentation arrangements and provide data for post processing algorithms ahead of test phase.
- Final demonstration using the validation rig within large wind tunnel with working section of >4 m would be desired.

Tasks for down-select and verification of novel advanced non-intrusive measurement techniques for full annulus flow field mapping within an Ultrafan®:

Tasks		
Ref. No.	Title - Description	Due Date
1	Down select of proposed measurement techniques	T0 + 6 months

Tasks		
Ref. No.	Title - Description	Due Date
2	Acquisition of appropriate instrumentation for chosen measurement techniques	T0 + 12 months
3	CFD results to develop ‘high order data analysis and pressure field reconstruction techniques’.	T0 + 14 months
4	Manufacture of coupled rig test validation hardware	T0 + 14 months
5	Conduct optical proof of concept test to demonstrate measuring equipment is suitable for future requirements	T0 + 20 months
6	Conduct wind tunnel test validation test phase in wind tunnel of approx. 2.4 to 3 m.	T0 + 24 months
7	Post processing algorithms validated using test data and CFD results.	T0 + 26 months
8	Final verification test in wind tunnel 2.4 to 3 m, or greater.	T0 + 28 months
9	Comparison of CFD predictions test data.	T0 +30 months.

Task 1

- Study to down select novel non-intrusive measurement techniques capable of achieving project objective and optimum solutions to achieve project objectives.
- Deliver report outlining opportunities and risks, and development requirements for each task, including suitability for high productivity wind tunnel testing.
- Agree choice of techniques with topic manager

Task 2

- Acquisition of appropriate measurement equipment required to achieve project objective of non-intrusive full annulus flow field mapping on coupled short intake test to required spatial and temporal resolution.
- Acquisition of instrumentation and hardware required for test intake for pressure field reconstruction technique

Task 3

- CFD prediction of appropriate High Bypass Ratio style intake and fan system, to develop instrumentation requirements and post processing algorithms.
- Validation of CFD against mutually agreed test case.

Task 4

- Manufacture of ‘proof of concept’ rig test hardware for validation wind tunnel test.
- Inspection of rig test hardware to confirm geometry conforms to design intent.

Task 5

- Conduct optical proof of concept test to show instrumentation concept is suitable for future requirements.

Task 6

- Conduct validation test with powered intake, in representative external flow field, (in a wind tunnel of approx. 2.4 to 3m, or greater), for both crosswind with ground plane and high incidence.
- Deliver dataset for post processing algorithms trial.

Task 7

- Develop post processing algorithms to rapidly interpret flow field data from the measurements.
- Use CFD results to provide initial test case ahead of test phase.
- Develop and validate algorithms to convert measured flow field data into intake compatibility

metrics.

- Confirm suitability of measured data for post processing algorithms and specify measurement enhancements, if required.

Task 8

- Final verification test of proposed measurement technique, ideally with rotating fan assembly, in a wind tunnel of 2.4 to 3 m or greater (6 to . 8 m working section would be desired).
- Conduct X-wind testing with a ground plane, and high incidence testing under specified operating range.
- Define instrumentation mounting arrangements for large approx. 8 m wind tunnel.
- Confirm measurement techniques meet primary Programme objectives, and identify method improvements.
- Deliver database for final verification of post processing algorithms.

Task 9

- Comparison of CFD complex flow predictions with post processed test data ‘data analysis and ‘pressure field reconstruction’
- Identify method enhancements for future test application.

3. Major Deliverables/ Milestones and schedule (estimate)

*Types: P=Plan, R=Report, D=Data, HW=Hardware, Rw=Review

Deliverables			
Ref. No.	Title - Description	Type*	Due Date
D1	Work Plan for all tasks	P	T0 + 2 months
D2	Proposal for measurement experimental method and equipment	R	T0 + 6 months
D3	Acquisition of instrumentation equipment for concept test.	HW	T0 + 12 months
D4	CFD results for instrumentation selection and post processing algorithm development	D + R	T0 + 14 months
D5	Wind tunnel model manufacture and measurement system assembly.	HW	T0 + 14 months
D6	Optical proof of concept ,check out summary for proposed future test requirement	R	T0 + 22 months
D7	Wind tunnel validation test for novel measurements complete.	D	T0 + 24 months
D8	Post processing algorithms fully defined	R	T0 + 24 months
D9	Measurement system validation report	R + D	T0 + 30 months
D10	Data processing algorithms validation report	R	T0 + 30 months

Milestones (when appropriate)			
Ref. No.	Title - Description	Type*	Due Date
M1	Work Plan agreed	R	T0 + 2 months
M2	Novel measurement, analysis and wind tunnel verification agreed.	Rw	T0 + 12 months
M3	Wind tunnel test model manufacture complete	HW	T0 + 14 months
M4	CFD results summary report	R	T0 + 18 months

Milestones (when appropriate)			
Ref. No.	Title - Description	Type*	Due Date
M5	Optical future test check out summary report	R	T0 + 22 months
M5	Validation Test results and data summary report	D + R	T0 + 24 months
M6	Measurement and analysis final verification	R	T0 + 30 months

4. Special skills, Capabilities, Certification expected from the Applicant(s)

Generic requirements include:

- Have substantial technical knowledge in the domain of the proposed tasks.
- Demonstrated expertise in project participation, international cooperation, project and quality management.
- Proven achievement record showing knowledge is recognised in the scientific community.

This specific package of work will require expertise in:

- Established track-record in the development of novel measurement techniques to deploy as ‘production methods’ in high productivity commercial large wind tunnels.
- Capability to plan, design and manufacture wind tunnel models to conduct specified measurement validation activity.
- Demonstrated ability to develop and deploy novel non-intrusive measurement systems in large wind tunnels with working sections greater than 2.4m to 3m
- Wind tunnel final verification testing will require testing in a representative environment, with a working section of 2.4m to 3m or greater, with a flowing intake system of approximately 250 to 350 mm fan face diameter. The verification facility shall be capable of simulating representative crosswind with ground plane up to 25 m/s, and high angle of attack conditions with the flight speeds in the M=0.12 to 0.30 range.
- Proven track record in development of non-intrusive measurement techniques, including PIV, within flowing jet engine intake ducts.
- Established track recording deploying optical techniques to measure complex jet engine intake flow fields within a wind tunnel environment.
- Proven ability to rapidly post process complex jet engine intake flow fields using high order numerical analysis methods, such as POD and extreme value theory, on dynamic non-intrusively recorded measurements.
- Proven ability to undertake pressure field reconstruction from velocity flow field data and derive intake compatibility metrics.
- Proven ability to plan and undertake phased development testing to mature novel non-intrusive measurement techniques within intake
- Proven ability to derive swirl distortion metrics from CFD and non-intrusive intake measurements
- Demonstrated capability to undertake validated CFD analysis of complex intake flow fields to utilise in conjunction with flow field measurements to derive intake compatibility pressure metrics.

5. Abbreviations

CFD	Computational Fluid Dynamics
Mn	Mach Number
TRL	Technology Readiness Level



POD Proper Orthogonal Decomposition.
PIV Particle Image Velocimetry
UHBR Ultra High Bypass Ratio (engine)

XII. JTI-CS2-2018-CfP09-LPA-01-69: Insulation Monitoring for IT Grounded (Isolation Terra) Aerospace Electrical Systems

Type of action (RIA/IA/CSA):		IA	
Programme Area:		LPA	
(CS2 JTP 2015) WP Ref.:		WP 1.6.1	
Indicative Funding Topic Value (in k€):		700	
Topic Leader:	Rolls-Royce	Type of Agreement:	Implementation Agreement
Duration of the action (in Months):	24	Indicative Start Date (at the earliest)²⁸:	Q3 2019

Topic Identification Code	Title
JTI-CS2-2018-CfP09-LPA-01-69	Insulation Monitoring for IT Grounded (Isolation Terra) Aerospace Electrical Systems
Short description	
<p>With an increase in the predicted demand for high voltage electrical power in large passenger aircraft, new electrical distribution systems will be required to enable safe, light, highly efficient electrical propulsion systems. Insulation monitoring technology is a crucial safety system on high integrity power distribution in land and marine systems, however they have not been optimised and made commercially available for aerospace. A functionally representative insulation monitoring system for aerospace is required, incorporating all the lessons and experience of established markets, but tailored to the specialised aerospace environment and its safety processes.</p>	

Links to the Clean Sky 2 Programme High-level Objectives²⁹				
This topic is located in the demonstration area:		Electrical Systems		
The outcome of the project will mainly contribute to the following conceptual aircraft/air transport type as presented in the scene setter:		Ultra-advanced Long-range Ultra-advanced Short/Medium-range		
With expected impacts related to the Programme high-level objectives:				
Reducing CO₂ emissions	Reducing NO_x emissions	Reducing Noise emissions	Improving EU Competitiveness	Improving Mobility
<input checked="" type="checkbox"/>	<input type="checkbox"/>	<input type="checkbox"/>	<input type="checkbox"/>	<input type="checkbox"/>

²⁸ The start date corresponds to actual start date with all legal documents in place.

²⁹ For further info see Chapter 1 “Introduction to the Programme Scene Setter / Objectives” with key technology themes / demonstration areas. Detailed information available in the CS2 Development Plan accessible via the Clean Sky JU Website and EC Participant Portal.

1. Background

Current Large Passenger Aircraft (LPA) use low voltage (below 1kVac rms or 1.5kVdc) distribution systems to transmit a relatively modest amount of power (below 1MW) for use in aircraft subsystems such as cabin conditioning and actuation. The existing power distribution systems often use the metallic airframe as the earthing system.

Electric propulsion systems have the potential to make a significant impact on LPA emissions, facilitating CO₂, NO_x and noise reductions. However to make electric or hybrid propulsion systems feasible, greater electrical power transmission at high voltage will be required. High power electrical systems in high reliability applications often utilise IT earthing (Isolation Terra). IT earthing brings known advantages of fault current management and continued operation post fault. It also brings the challenge of correctly determining when an insulation fault has occurred, allowing the system to safely reconfigure or shutdown.

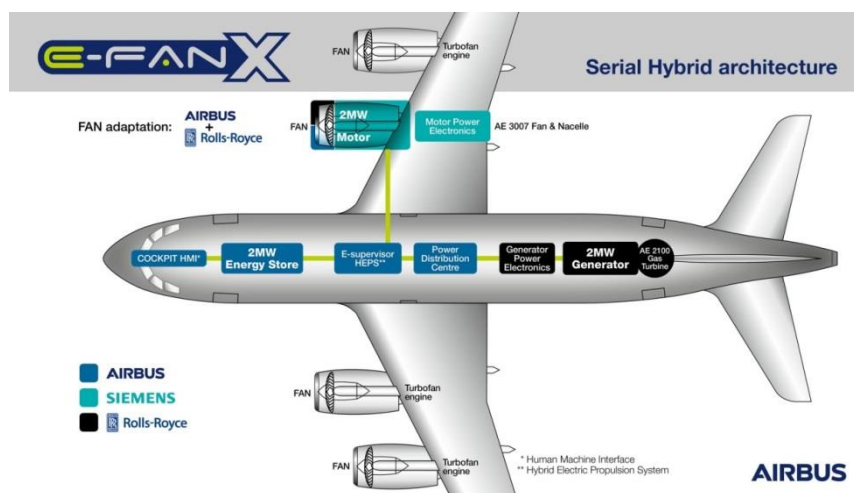

There are currently no large electric or hybrid aerospace power systems in operation, therefore no proven insulation monitoring systems are available at TRL6 or above. Demonstrators, such as E-Fan X (see above Figure), are planned by numerous European aerospace companies and while all are likely to require insulation monitoring as a system enabler, few companies have significant experience with creating insulation monitoring systems.

The lessons and experience of established markets, such as maritime vessels, solar power and traction systems can be brought to bear to speed development, while tailoring the packaging and functionality to the specialised aerospace environment and its safety processes.

Aerospace offers a hostile environment for electrical equipment with frequent extreme temperature and pressure cycling from approximately 55°C at 1atm to -55°C at 0.2atm for every flight; along with difficulties common to other applications such as high vibration, contamination, humidity and condensation. Electrically the installation is functionally similar to those seen on industrial and transport applications, but with stringent safety and reliability challenges, especially when used for electric propulsion. Safety critical architectures may push reliability requirements to a rate of 1e-9.



The simple objective of the Work Package is to make available a functionally representative insulation monitoring system for aerospace applications, incorporating all the lessons and experience of established markets, but tailored to the specialised aerospace environment and its safety processes. Testing in a representative environment at altitude and temperature is expected in line with aerospace environment requirements.

This strategic theme falls under the umbrella of Clean Sky 2 Platform 1 work package (WP) 1.6.1 – Alternative Energy Propulsion Architecture & Components within the Clean Sky 2 Large Passenger Aircraft (LPA).

The Work Breakdown Structure (WBS) will include three Work Packages (WP's) as below:

- WP1: Analysis of applicable systems to obtain requirements and targets for development.
- WP2: Modelling and development of aerospace applicable technologies.
- WP3: Hardware build, testing and validation.

2. Scope of work

Requirements:

An insulation monitoring system shall be developed up to TRL6.

The system shall be suitable for use on high voltage distribution systems, over 1000Vac rms and 1500Vdc.

The system shall be suitable for use on systems with a power of 4MW.

The system should be suitable for use on systems with representative capacitance to earth, to be discussed with the Topic Manager.

The system should be tested and able to operate in representative environmental conditions to be discussed with the Topic Manager, the installation location is likely to require operation in a low pressure (0.7 atm) environment. It is acknowledged that a supplier may need to use external facilities to prove this validation.

Tasks		
Ref. No.	Title – Description	Due Date
1.1	Aerospace environment and system – The environment and system characteristics pertinent to insulation monitoring need to be understood and documented to ensure the system can be easily integrated.	T0 + 1
1.2	Performance and operational requirements – Capture the requirements from the Topic Manager, making sure the systems performance will be adequate.	T0 + 3
1.3	Gap analysis – A comparison between current available insulation monitoring systems and aerospace requirements to direct development work.	T0 + 5
2.1	System model – Modelling of typical system including monitoring device to benchmark the development of new technology both simulated hardware and software.	T0 + 9
2.2	Technology development – Develop insulation monitoring technology and enabling systems to bridge gaps defined earlier in project.	T0 + 17
3.1	Prototype – Prototype unit production or prototype components/software as required for demonstration of capability.	T0 + 19

Tasks		
Ref. No.	Title – Description	Due Date
3.2	Testing and validation – Against the requirements from the Topic Manager and the environment and system assessments. Environmental conditions, such as altitude and temperature are to be discussed with the Topic Manager as they will depend on installation location. It is acknowledged that a supplier may have to hire external facilities to prove this validation.	T0 + 22
3.3	Customer verification – Reviewing and trialling monitoring systems with the Topic Manager.	T0 + 23

3. Major Deliverables/ Milestones and schedule (estimate)

*Type: R=Report, D=Data, HW=Hardware

Deliverables			
Ref. No.	Title – Description	Type*	Due Date
D1.3	Summary of research requirements and gap analysis.	R	T0 + 5
D2.1	Summary of technology developments and future roadmap.	R	T0 + 17
D3.1	Verification of proposed prototype with the Topic Manager.	R	T0 + 23

Milestones (when appropriate)			
Ref. No.	Title – Description	Type*	Due Date
M1.3	Research requirements and gap analysis completed.	D	T0 + 5
M2.1	Summary of technology developments and future roadmap.	R	T0 + 17
M3.3	Verification of proposed prototype with the Topic Manager.	R	T0 + 23

4. Special skills, Capabilities, Certification expected from the Applicant(s)

- Understanding of state of the art in insulation monitoring systems – there is no desire for the aerospace supply chain to reinvent insulation monitoring. There are highly effective systems that can provide solid grounding for aerospace specific systems.
- Ability to produce production insulation monitoring hardware – this project aims to get working hardware available at TRL6, to do this production arrangements are necessary.
- Aerospace supplier potential – investment and capability growth may be required to provide aerospace standard product, the applicant will need to be committed to this.

5. Abbreviations

IT	Isolation Terra
TRL	Technology Readiness Level
LPA	Large Passenger Aircraft
rms	Root Mean Square

XIII. JTI-CS2-2018-CfP09-LPA-01-70: Assessment of arc tracking hazards in high voltage aerospace systems

Type of action (RIA/IA/CSA):		IA	
Programme Area:		LPA	
(CS2 JTP 2015) WP Ref.:		WP 1.6.1	
Indicative Funding Topic Value (in k€):		750	
Topic Leader:	Rolls-Royce	Type of Agreement:	Implementation Agreement
Duration of the action (in Months):	30	Indicative Start Date (at the earliest)³⁰:	Q3 2019

Topic Identification Code	Title
JTI-CS2-2018-CfP09-LPA-01-70	Assessment of arc tracking hazards in high voltage aerospace systems
Short description	
Arc tracking is already a significant issue in existing aerospace electrical systems operating at 115VAC and 230VAC and can cause significant damage to wiring. Moreover the impact of arc tracking on future systems operating at higher voltages, such as series hybrid electric systems, has not been assessed. This project should quantify the risk of arc tracking in megawatt scale aircraft electrical systems operating at high voltages (>1.5kV DC). The project should develop the fundamental understanding and consider what measures should be taken to safeguard the aircraft electrical system from resultant damage. The project should consider the configurations of cable likely to be used in higher voltage applications and the different voltage types (DC, AC, converter fed).	

Links to the Clean Sky 2 Programme High-level Objectives³¹				
This topic is located in the demonstration area:		Electrical Systems		
The outcome of the project will mainly contribute to the following conceptual aircraft/air transport type as presented in the scene setter:		Ultra-advanced Long-range Ultra-advanced Short/Medium-range		
With expected impacts related to the Programme high-level objectives:				
Reducing CO₂ emissions	Reducing NO_x emissions	Reducing Noise emissions	Improving EU Competitiveness	Improving Mobility
<input checked="" type="checkbox"/>	<input type="checkbox"/>	<input type="checkbox"/>	<input checked="" type="checkbox"/>	<input type="checkbox"/>

³⁰ The start date corresponds to actual start date with all legal documents in place.

³¹ For further info see Chapter 1 "Introduction to the Programme Scene Setter / Objectives" with key technology themes / demonstration areas. Detailed information available in the CS2 Development Plan accessible via the Clean Sky JU Website and EC Participant Portal.

1. Background

With regard to meeting the Flightpath 2050 targets, the optimisation of gas turbine engines and airframe in isolation may not yield the required levels of improvement and more integrated aircraft designs will subsequently be required. The most optimum solutions are likely to benefit from distributed propulsion concepts that will not only increase propulsive efficiencies, but will also improve an aircraft's aerodynamic characteristics by providing propulsive force when and where required. The key enabler for distributed propulsion is the hybrid electrical power transmission, which will efficiently distribute the power throughout the propulsion system.

In order to open up this new design space, a number of challenges have to be first understood and then overcome. One of the major challenges being faced is the need to increase the system voltage substantially above that previously utilised for aircraft applications in order to reduce the weight of the whole electrical system, from genset to propulsor, to acceptable levels mainly through cable weight reduction. For example, the current E-Fan X demonstrator project (see Figure below) is utilising a DC bus voltage of 3kV. This is well above the 540V DC used for the Boeing 787 more electric aircraft, which in itself is double the standard system voltage of 270V DC in common use for many aircraft. For the purposes of this project, systems with bus voltages in the range 1.5kV to 4.5kV DC should be considered along with the other voltages that will be seen on the cabling system that are near sinusoidal AC and/or converter fed waveforms.

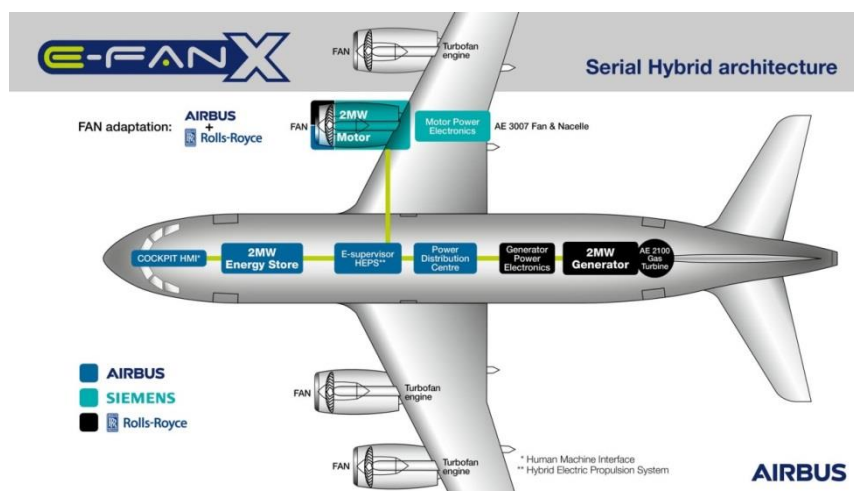

Arc tracking, a progressive failure mechanism forming a carbonised path across an electrical insulation system, is already a significant issue in existing aerospace electrical systems and can cause significant damage to wiring. Moreover the impacts of arc tracking on future systems operating at higher voltages (such as series hybrid electric systems) and the impacts of likely changes in cable design / protection system configuration have not been assessed.

This project should quantify the risk of arc tracking in >1MW aircraft electrical systems operating at high voltages (>1.5kV DC and corresponding levels of AC / converter voltages) through experimental techniques, using an environmental chamber or similar to simulate representative temperatures, pressures and humidity. This should also include an investigation into safe separation (spacing requirements to ensure that there is no risk to other systems during an arc fault). Modelling of the arc tracking process should be conducted to estimate the magnitude of the current that will flow during a

fault. It is likely that such a model will need to represent the physics of the arc itself as well as taking a system level view of the impedance of the system and the nature of the protection. The project should develop the fundamental understanding (to TRL3) and consider what measures should be taken to safeguard the aircraft electrical system from resultant damage.

The Work Breakdown Structure (WBS) will include three Work Packages (WP's) as below:

- WP1: Build an understanding of arc tracking hazards and develop a means of modelling the arc tracking process (including the arc itself, the response of materials, the power system topology and the impact of the power system protection at a system level)
- WP2: Using experimental techniques, investigate the arc tracking process on systems operating at higher voltages in representative environmental conditions including safe separation and validating the modelling in WP1
- WP3: Define a range of measures to mitigate arc tracking risks for high voltage aircraft electrical systems by linking the work in WP1 and WP2

This strategic theme covers work package WP1.6.1 – Alternative Energy Propulsion Architecture & Components within the Clean Sky 2 Large Passenger Aircraft (LPA) – Platform 1. This topic is complementary to JTI-CS2-2018-CFP08-LPA-01-55 “Development of AC cabling technologies for >1kV aerospace applications.” The current call goes beyond the scope of the previous call to specifically examine failure modes and improve understanding in this novel area.

2. Scope of work

Requirements: > 1 MW, high voltages (>1.5kV DC), development up to TRL 3

Tasks		
Ref. No.	Title - Description	Due Date
Task 1.1	Review existing knowledge of arc tracking hazards in aerospace applications and relevant knowledge from ground based power systems	T0 + 3
Task 1.2	Develop a means of modelling the arc tracking process and corresponding effects on the aircraft electrical system	T0 + 6
Task 2.1	Devise experimental techniques and test procedures for investigating the arc tracking process on higher voltage systems (as specified for E-Fan X) including safe separation	T0 + 9
Task 2.2	Conduct experimental testing to investigate the arc tracking process, its impact and mitigation methods - this should be undertaken in representative environmental conditions	T0 + 17
Task 2.3	Use the test results from Task 2.2 to validate the modelling undertaken in Task 1.2	T0 + 19
Task 2.4	Prepare a full report on test results and conclusions	T0 + 21
Task 3.1	Based on the report generated in Task 2.4, define a range of measures to mitigate arc tracking risks for high voltage aircraft electrical systems	T0 + 23
Task 3.2	Produce a design guidance document for high voltage aircraft electrical systems to provide advice on how to mitigate against and reduce the impact of arc tracking	T0 + 24

3. Major Deliverables/ Milestones and schedule (estimate)

*Type: R=Report, D=Data, HW=Hardware

Deliverables			
Ref. No.	Title - Description	Type*	Due Date
D1.1	Literature Survey report on arc tracking hazards	R	T0 + 3
D1.2	Documented model of arc tracking across an insulator with user guide for model	R, D	T0 + 6
D2.1	Report on arc tracking test results and conclusions	R	T0 + 21
D3.1	Design guidance document for high voltage aircraft electrical systems	R	T0 + 24

Milestones (when appropriate)			
Ref. No.	Title - Description	Type*	Due Date
M1.1	Modelling of the arc tracking process complete	D	T0 + 6
M2.1	Procedures defined for arc tracking tests	R	T0 + 9
M2.2	Experimental testing complete	HW	T0 + 17
M2.3	Validation of models complete	D	T0 + 19
M3.1	Measures to mitigate arc tracking risks captured	R	T0 + 23

4. Special skills, Capabilities, Certification expected from the Applicant(s)

- Understanding of the theory behind arc tracking and the ability to perform modelling of the wider system at a level appropriate to the phenonema
- Capability to provide test samples representative of those in existing aircraft and future High Voltage systems
- Skilled in understanding environmental conditions and certification requirements for aerospace applications including cabling systems and those of future high voltage systems
- Experimental facilities relevant for arc tracking testing

5. Abbreviations

AC	Alternating Current
DC	Direct Current
LPA	Large Passenger Aircraft
TRL	Technology Readiness Level
WBS	Work Breakdown Structure
WP	Work Package

XIV. JTI-CS2-2018-CfP09-LPA-01-71: Innovative Nacelle cowl opening system

Type of action (RIA/IA/CSA):		IA	
Programme Area:		LPA	
(CS2 JTP 2015) WP Ref.:		WP 1.5.2	
Indicative Funding Topic Value (in k€):		700	
Topic Leader:	Airbus	Type of Agreement:	Implementation Agreement
Duration of the action (in Months):	36	Indicative Start Date (at the earliest)³²:	Q3 2019

Topic Identification Code	Title
JTI-CS2-2018-CfP09-LPA-01-71	Innovative Nacelle cowl opening system
Short description	
Future Ultra High by-pass Ratio engines are bringing new challenges in integration onto the airframe. These challenges are met by introducing short nacelles with slim aero lines. New solutions for the nacelle cowling system need to be developed, i.e. new compact actuation systems to open the cowls for maintenance are necessary. The proposed activity will consist in defining and testing a new cowl opening actuation system compliant with these new requirements, with a target for a TRL6 level, for potential exploitation on a future Long Range aircraft.	

Links to the Clean Sky 2 Programme High-level Objectives³³				
This topic is located in the demonstration area:	Ultra-high Bypass and High Propulsive Efficiency Geared Turbofans			
The outcome of the project will mainly contribute to the following conceptual aircraft/air transport type as presented in the scene setter:	Advanced Long-range			
With expected impacts related to the Programme high-level objectives:				
Reducing CO₂ emissions	Reducing NO_x emissions	Reducing Noise emissions	Improving EU Competitiveness	Improving Mobility
<input checked="" type="checkbox"/>	<input type="checkbox"/>	<input type="checkbox"/>	<input type="checkbox"/>	<input type="checkbox"/>

³² The start date corresponds to actual start date with all legal documents in place.

³³ For further info see Chapter 1 "Introduction to the Programme Scene Setter / Objectives" with key technology themes / demonstration areas. Detailed information available in the CS2 Development Plan accessible via the Clean Sky JU Website and EC Participant Portal.

1. Background

The next generation propulsion systems will offer significant propulsive efficiency improvements through Ultra High Bypass Ratio (UHBR), low Fan Pressure Ratio fans, however at the expense of a strong increase in engine diameter.

Engine cores work at higher temperatures & become smaller compared to the fan.

UHBR propulsion systems will only deliver attractive fuel burn benefits at aircraft level if the integration of the propulsion system and its installation onto the aircraft offset the burden of much larger and heavier engines

The integration of the propulsion system & its installation onto the aircraft are thus key enablers to maximize the fuel and CO₂ savings.

Among the various challenges directly linked to the large fan diameter and extremely wing/engine close coupling, the current maintainability approach and accessibility to Engine and Nacelle components have to be rethought in a more compact and efficient way.

In this frame, and compared to the traditional architecture (see illustration below called D-Duct nacelle cowl opening system), it is necessary to develop innovative nacelle cowl opening systems to open either fan cowls or Thrust Reverser type cowls



Current State of the art for nacelle cowls opening is linear electromechanical ball screw or hydraulic.

New high by-pass ratio (UHBR) engine integration leads to contemplate new design of cowls rather than the regular "D-Duct" in order to ensure best close coupling to the wing, without compromising maintainability access to engine compartments.

Such new cowls concept leads to split the thrust reverser cowling system in two parts: external and internal cowls.

The internal cowl, which forms the aerodynamic fairing around the engine core, brings new challenges to the cowl opening system, due to the highly constrained space allocation and high temperature and vibration environment, which implies a brand new equipment architecture.

The schematic illustration below shows the area where the new concept will be developed and tested:

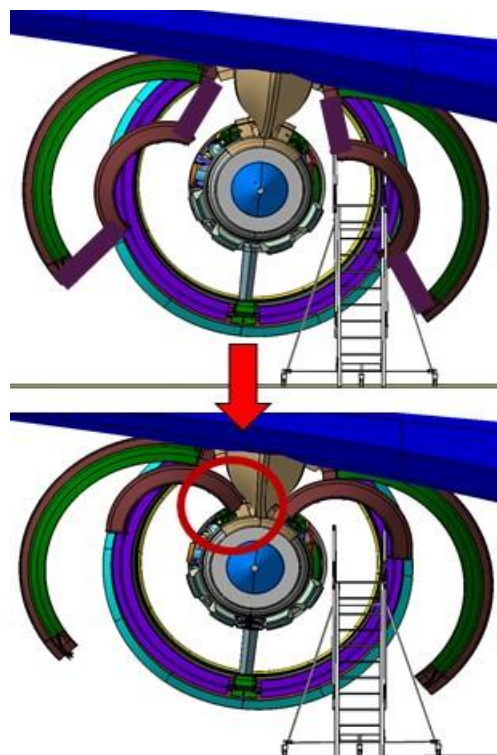

Benefit of the technology: this new Cowl Opening System (COS) concept is an enabler of the nacelle architecture which brings high value for new UHBR engines integration (weight, drag & Specific Fuel Consumption reduction).

2. Scope of work

The applicant(s) will be in charge of designing and developing a innovative prototype of a Nacelle cowl opening system with the objective to perform the final integration onto the Airbus test environment.

The applicant(s) will be working in relation with the topic manager who will provide at the project start the main requirements and interfaces to the applicant, among which the space envelop, the functional interfaces (both electrical and mechanical) and any other design constraints about maintainability, safety, loads, environmental constraints...

The applicant(s) will work together with Airbus to elaborate a solution compatible with the requirements.

The applicant(s) will be in charge of the design and the development of a prototype including the most advanced innovative techniques and will provide the 3D detailed models to the topic manager for integration onto the 3D targeted nacelle design (DMU).

The applicant(s) will define a development plan with the aim to reach TRL6 at completion of the activity, including major gates and milestones. A TRL process will be implemented from the onset of the activity and TRL reviews will be held with the involvement of the topic manager all along the development phase of the prototype. All the major development gates will be commonly validated by the applicant(s) and the topic manager, including the assessment of the compliance of the prototype vis a vis the requirements.

The integration of the nacelle and its validation against environmental requirements will be performed at Airbus facilities in its own environment (incl. the test means).



The applicant(s) will provide a solution matching the main novelties and typical aeronautical characteristics expected for this new component, as given belows:

- Short opening time (typically less than 1 mn)
- Usual number of opening/closing sequences (~4000 cycles) for typical aircrafts in operation
- Lock cowl at any opened position in case of loss of power
- Lock cowl at any desired position
- Shall not transfer any loads when unlocked in closed position
- No single mechanical or system failure shall lead to a inadvertent cowl closure
- It shall be possible to actuate the system by an external mean in the event of loss of any electrical/hydraulic function
- Usual thermal constraints insuch engine/nacelle environment in flight, as for example, when not operating, component shall resist to a temperature range from -55°C to +370°C and vibrations w/o impacting its operational performance and durability.

The main benefits expected from the solutions proposed by the applicant can be summarised as follows:

- Light weight
- Compacity
- Maintanability
- Friendly, easy and secure use

3. Major Deliverables/ Milestones and schedule (estimate)

*Type: R=Report, D=Data, HW=Hardware

The main tasks for this topic are envisaged as follows:

Tasks		
Ref. No.	Title - Description	Due Date
T_1	Analysis of the specification – transformation of high level requirements into detailed requirements	T0+2months
T_2	Identification of state of the art for similar components	T0+3months
T_3	Preliminary concepts proposals & pre-sizing – down-selection (TRL3)	T0+9months
T_4	Definition of selected concept and first performance test (prototype in a non-representative environment, demonstration of feasibility (TRL4)	T0+16months
T_5	Detailed definition of a product representative prototype & performance test at component level (TRL5)	T0+28months
T_6	Integration test of the prototype on a scale 1 half-nacelle (TRL6 part 1)	T0+30months
T_7	Environmental & endurance qualification to demonstrate compliance to products requirements (TRL6 part2)	T0+38months

Deliverables			
Ref. No.	Title - Description	Type*	Due Date
D_1	Development plan (including technology readiness roadmap)	R	T0
D_2	Specification compliance Matrix & derived component requirements	R	T0+2months
D_3	State of Art analysis	R	T0+3months

Deliverables			
Ref. No.	Title - Description	Type*	Due Date
D_4	TRL3 dossier (preliminary concept definition, pre-sizing, down selection criteria, concept DMU, interface loads)	R + D	T0+9months
D_5	Concept Prototype test report	R	T0+15months
D_6	TRL4 dossier (Concept pre-sizing, test report, compliance, Behavioural model)	R	T0+16 months
D_7	Product representative definition dossier (sizing, compliance to spec, DMU, Behavioural model)	R + D	T0+20 months
D_8	Product representative prototype	HW	T0+26months
D_9	Product representative prototype performance test & report (TRL5)	R + D	T0+28months
D_10	Product representative prototype Integration test & report	R + D	T0+30months
D_11	Product representative prototype environmental test & endurance report	R + D	T0+36months
D_12	Final review (Maturity & compliance demonstration – TRL6)	R	T0+38months

Milestones (when appropriate)			
Ref. No.	Title - Description	Type*	Due Date
M_1	Kick of Meeting	R	T0
M_2	TRL3	R	T0+9months
M_3	TRL4	R	T0+16months
M_4	TRL5	R	T0+28months
M_5	Product representative prototype acceptance review (before HW delivery to integration test bench)	R	T0+26months
M_6	TRL6	R	T0+38months

4. Special skills, Capabilities, Certification expected from the Applicant(s)

- Aeronautics equipment design & manufacturing for civil A/C applications (CS25 knowledge)
- Experience in electromechanical and/or hydromechanical actuation systems for flight controls, doors opening systems
- Experience in electrical or hydraulic torque motors, geartrains, locking features, brakes
- Experience in systems engineering, systems performance tests and qualification tests (DO160)
- Airbus systems requirements knowledge would be appreciated (ABD100)

5. Abbreviations

DMU Digital Mock Up
 TRL Technology Readiness Level

XV. JTI-CS2-2018-CfP09-LPA-02-27: Innovative mould for thermoplastic skin of the lower fuselage demonstrator

Type of action (RIA/IA/CSA):		IA	
Programme Area:		LPA	
(CS2 JTP 2015) WP Ref.:		WP 2.1.5	
Indicative Funding Topic Value (in k€):		950	
Topic Leader:	Netherlands Aerospace Centre	Type of Agreement:	Implementation Agreement
Duration of the action (in Months):	30	Indicative Start Date (at the earliest)³⁴:	Q3 2019

Topic Identification Code	Title
JTI-CS2-2018-CfP09-LPA-02-27	Innovative mould for thermoplastic skin of the lower fuselage demonstrator
Short description	
Research for an innovative mould is needed for efficient high volume production of the thermoplastic fuselage skin. This call topic aims to develop such mould for skin consolidation in autoclave, including automated lay-up, assembly, and transport for the large lower fuselage demonstrator. The heated and cooled mould is aimed to be used as well for smaller demonstrators, including out-of-autoclave consolidation (e.g. in-situ).	

Links to the Clean Sky 2 Programme High-level Objectives ³⁵				
This topic is located in the demonstration area:		Cabin & Fuselage		
The outcome of the project will mainly contribute to the following conceptual aircraft/air transport type as presented in the scene setter:		Advanced Long-range Advanced Short/Medium-range		
With expected impacts related to the Programme high-level objectives:				
Reducing CO₂ emissions	Reducing NO_x emissions	Reducing Noise emissions	Improving EU Competitiveness	Improving Mobility
<input type="checkbox"/>	<input type="checkbox"/>	<input type="checkbox"/>	<input checked="" type="checkbox"/>	<input type="checkbox"/>

³⁴ The start date corresponds to actual start date with all legal documents in place.

³⁵ For further info see Chapter 1 "Introduction to the Programme Scene Setter / Objectives" with key technology themes / demonstration areas. Detailed information available in the CS2 Development Plan accessible via the Clean Sky JU Website and EC Participant Portal.

1. Background

Large Passenger Aircraft (LPA) Platform 2 – Multifunctional Fuselage Demonstrator

The objective of Large Passenger Aircraft (LPA) Platform 2 – Multifunctional Fuselage Demonstrator (MFFD) is to validate high potential combinations of airframe structures, cabin/cargo, and system elements using advanced materials and applying innovative design principles in combination with the most advanced system architecture for the next generation fuselage and cabin.

The overall objectives of the MFFD are:

- Enable a high production rate of a minimum of 60 aircraft per month
- Achieve a total fuselage weight reduction of 1000kg
- Achieve a reduction of recurring costs

WP2.1.5 Lower half of the Multifunctional Fuselage Demonstrator

Development of the lower half of the multifunctional fuselage demonstrator started. This work package will develop, manufacture and deliver a 180° full scale multi-functional integrated thermoplastic (PEKK) lower fuselage shell, including cabin and cargo floor structure and relevant main interior and system elements (lower fuselage demonstrator).

The applicants work will involve key aspects of the MFFD and as such is linked to WP2.1.5.

Figure 1 provides a view on the lower half fuselage module concept. The skin has lightning strike protection at its outer surface.

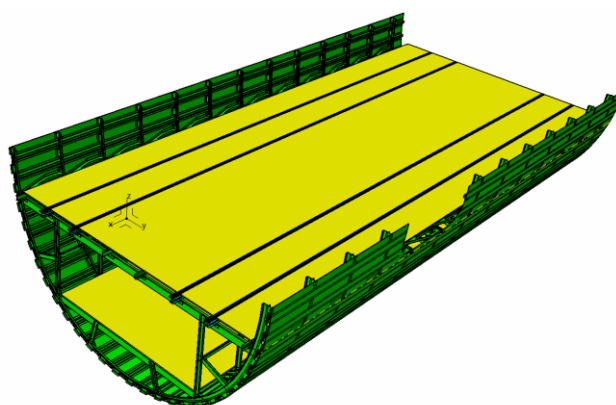

Figure 1: Overview of the lower fuselage demonstrator

Innovative mould for thermoplastic skin of the lower fuselage

Composites fuselages of recent new aircraft types such as A350 are produced on male moulds. Thickness variation of the skin allows to have minimum weight according to the different loads borne by each part of the frame. However, thickness variation also leads to complex surface geometry of male moulds, which makes them expensive. Also late changes in thickness design are a large cost/schedule risk due to the long lead times of male moulds.

The lower half of the multifunctional fuselage demonstrator will therefore be based on a female mould. With the envisaged long sections of the multifunctional fuselage the size of this female mould is unique for aircraft applications. This also results in challenges for the controlled cooling down of the skin and mould during consolidation. The innovative mould for the thermoplastic skin of the lower fuselage demonstrator not only serves the manufacturing of the this demonstrator, but is also a demonstrator in

itself of the mould for high volume production of such skins for advanced short/medium range aircraft.

During composites skin production a mould needs to support the skin from its lay-up until it has been connected to the fuselage frames. Different moulds would increase the cost, increase the ecological footprint and require complex handling of the skin from one mould to another. Therefore it is requested to investigate a single multi-functional mould for automated lay-up, consolidation, transport and assembly. Due to the large size of the section the mould should add minimal size during transport and during consolidation (whenever in autoclave).

The single multi-functional mould also contributes to the cost efficiency of the lower fuselage demonstrator, for which it will be used at most a few times. To increase further its use the mould for the fuselage demonstrator shall be separable in smaller parts, each of which can be used alone or in junction with neighbouring parts as a mould for smaller demonstrators of critical skin manufacturing technologies.

For further cost-efficiency and to decrease the ecological footprint of the high volume production processes the mould shall be efficiently heatable. In case of consolidation in autoclave, mould heating and cooling may shorten the autoclave cycle. With the heated and cooled mould, out-of-autoclave consolidation (e.g., in-situ consolidation) can be investigated on the separated parts of the mould.

The skin materials typically do not stick to the mould. Due to the shape (and the position) of the mould, gravity may be counteracting. This requires investigation of mould technologies that keep the product connected during lay-up and thereafter, while the product is efficiently releasable after consolidation.

2. Scope of work

Tasks		
Ref. No.	Title - Description	Due Date
T1	Mould concept designs and selection	T0+3M
T2	Mould design for lower fuselage demonstrator	T0+5M
T3	Mould manufacturing for lower fuselage demonstrator	T0+10M
T4	Mould test, verification, delivery, and demonstration for lower fuselage demonstrator	T0+12M
T5	Design of the enhanced mould for smaller demonstrators	T0+16M
T6	Manufacturing of the enhanced mould for smaller demonstrators	T0+24M
T7	Test, verification, delivery, and demonstration of the enhanced mould for smaller demonstrators. Final reporting.	T0+30M

The work is split into three phases. During the first phase (Task 1) the applicant investigates and proposes new or improved female (OML) mould concepts (including materials and processes) for large thermoplastic (PEKK) fuselage skins.

This phase has two results: the concept definition and preliminary concept(s) definition(s) in relation to two kinds of usage of the mould. The first result is the concept definition of the female mould for the skin of the lower fuselage demonstrator.

It is expected that not all mould functionality investigated during phase 1 can be used for the skin of the lower fuselage demonstrator and thereby validated. Therefore, the mould shall be separable into multiple parts in longitudinal and transversal direction, as illustrated in Figure 2. These parts, either separately or joined with neighbouring parts, are part of the enhanced mould. The enhancement

concerns additional mould functionality that is not in the mould for the skin of the lower fuselage demonstrator. The enhanced mould is for use by the Topic Manager in smaller demonstrators of thermoplastic fuselage shell (including research for out-of-autoclave skin consolidation concepts, e.g. in-situ) and for broader validation of the innovative mould concepts for high volume production of such skins for advanced short/medium range aircraft.

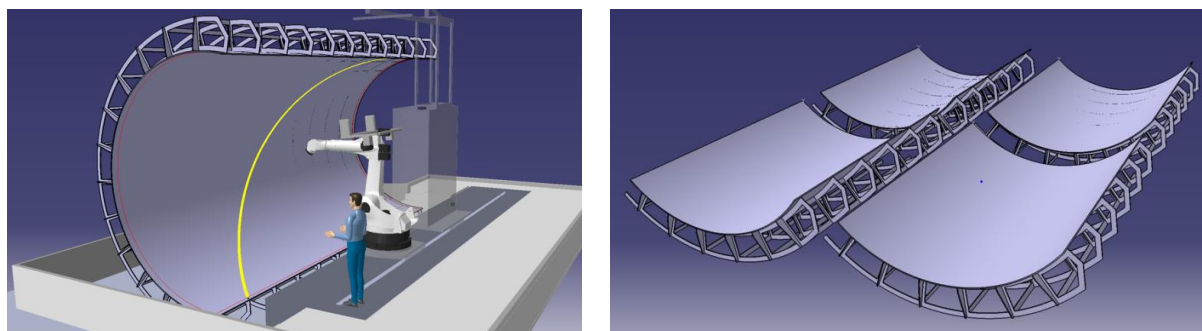

Figure 2: Illustration of a potential use case for the mould as developed in phases 1 and 2, the separability of the mould, and the enhanced mould as developed in phases 1 and 3.

The second result of the first phase is the definition of preliminary concept(s) for the enhanced mould. Both results from the first phase, concept for the mould and preliminary concept(s) for the enhanced mould, have to be approved by the Topic Manager.

During the second phase (Tasks 2-4), the mould for the skin of the lower fuselage demonstrator shall be designed, manufactured and delivered. During the third phase (Tasks 5-7) the enhanced mould is further investigated, designed, manufactured, and delivered.

In more detail the tasks are described as follows. In Task 1 the mould concepts are investigated, in close collaboration with the Topic Manager, for the female mould for the 180o, up to 9m long, with diameter of approximately 4m, skin of the lower fuselage demonstrator, which is not being circular in cross section. The mould shall be separable (as explained above and illustrated in Figure 2) with each of its parts satisfying the following mould specifications.

The mould shall be usable for consolidation (both in autoclave at max. 400oC and out-of-autoclave), for automated lay-up, for preform assembly, and for transport of the thermoplastic skin. The mould is at least 20 cm larger, in all directions, than the product that is to be manufactured on it, still following the contour of the fuselage skin. The size of the mould shall be minimal during consolidation, consistent with autoclave dimensions, and during transport. During assembly human may be working on the thermoplastic skin inside the mould.

The applicant shall propose innovative solutions to provide all of the following functions:

- Low cost, long life for high volume production
- Efficient heating of the mould up to 400oC with low energy consumption and fast, controlled cooling to shorten the consolidation cycle
- Keep the thermoplastic product layers connected to the mould, from lay-up until vacuum bagging before consolidation (e.g. removable vacuum system without any negative impact on surface quality during consolidation)
- Positioning system for multiple preforms (fool-proof) that can be re-used for different skin products.

The applicant proposes the materials for mould, such as multi-material solutions (e.g. floating Invar surface on steel substructure). In the proposal the solution for the mould structure has to be shown equivalent or better than the common Invar solution, including thermal behaviour and surface quality for the temperatures up to 400 oC. The mould shall be tiltable between several positions, including horizontal and vertical positions. The innovative solutions are proposed together with supporting first analyses and/or demonstrations, including thermal analysis of the cooling. Interface flexibility has to be provided for the interface with different autoclaves.

To demonstrate the suitability for the product manufacturing process, the mould shall be suitable to manufacture skin products on it that fit with aeronautical quality standards. Geometrical tolerances permitted for the aeronautical sector shall be respected. The mould geometry shall not be affected by the number of curing cycles during expected lifetime. If the mould geometry is altered unexpectedly it shall be cost-effective to modify the tool back to its original geometry. This is to be validated by analysis. The impact of the replacement of tooling on the recurring cost or production rate shall be non-significant. This is to be validated by analysis.

In Task 2 the mould for the lower fuselage demonstrator is designed. The design includes more detailed analyses and/or demonstrations. In Task 3 the mould is manufactured. In Task 4 the mould is verified and delivered at the Topic manager’s facility, where its operation is demonstrated.

In Task 5 the preliminary enhanced mould concept(s) are reviewed, refined when needed, and the final enhanced mould concept is selected with approval of the Topic Manager. Next the enhanced mould is designed in more detail with supporting analyses and/or demonstrations. In Task 6 the enhanced mould is manufactured. Finally, in Task 7, the enhanced mould is tested, verified and delivered to the Topic Manager. The reporting activities under the GAP are finalised.

3. Major Deliverables/ Milestones and schedule (estimate)

*Types: R=Report, RM=Review Meeting, D-Data, HW=Hardware

Deliverables			
Ref. No.	Title - Description	Type*	Due Date
D1	Innovative mould concepts and selection, including first analyses. Mould concept for the lower fuselage demonstrator. Preliminary concept(s) for the enhanced mould for smaller demonstrators.	R	T0+3M
D2	Mould for lower fuselage demonstrator technical data package: consisting of design description, material description, and supporting (mechanical, thermal, ...) analysis results	R, D	T0+5M
D3	Mould for lower fuselage demonstrator	HW	T0+10M
D4	Mould test and verification report	R	T0+11M
D5	Enhanced mould for smaller demonstrators technical data package: consisting of design description, material description, and supporting (mechanical, thermal, ...) analysis results	R, D	T0+16M
D6	Enhanced mould for lower fuselage demonstrator	HW	T0+24M
D7	Enhanced mould test and verification report	R	T0+27M

Milestones (when appropriate)			
Ref. No.	Title - Description	Type*	Due Date
MS1	Concept evaluation review closed	RM	T0+3M
MS2	Mould design review closed for lower fuselage demonstrator	RM	T0+5M
MS3	Mould for lower fuselage demonstrator delivered	HW	T0+11M
MS4	Design review closed for enhanced mould	RM	T0+16M
MS5	Enhanced mould delivered	HW	T0+27M
MS6	Final reporting completed	RM	T0+30M

Estimated Gantt Chart

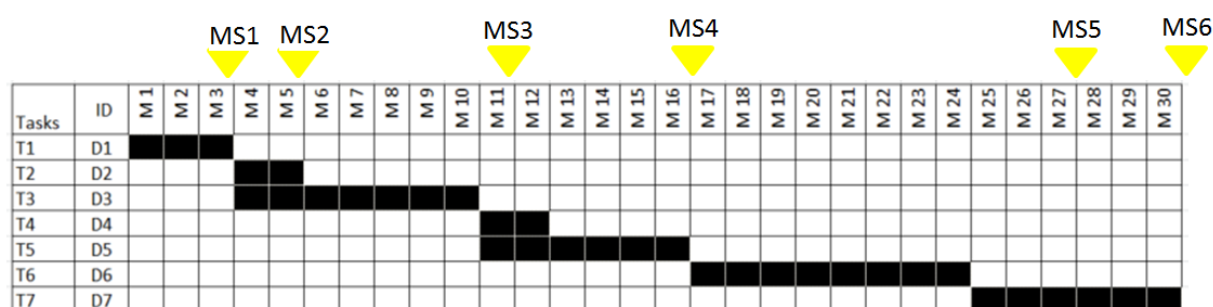

4. Special skills, Capabilities, Certification expected from the Applicant(s)

- Proven experience in moulds and proposed mould materials for automated lay-up and consolidation in autoclave of thermoplastic products suitable for high volume series production, aerospace experience will be beneficial
- Knowledge of aerospace products, development, quality requirements
- Experience in the proposed innovative solutions for high volume production, mould heating/cooling, connection of thermoplastic product layers to the mould, and positioning system
- Proven experience in providing supporting analysis (including mechanical, thermal)
- Proven capability to manufacture the mould of the require size
- Proven experience in designing and manufacturing moulds, the corresponding project management, and to work in shared international R&T projects
- CAD capability in Catia for compatibility with Topic Manager
- The applicant demonstrates to have existing supply chains for the proposed materials for the mould structure.

5. Abbreviations

GAP	Grant Agreement for Partners
LPA	Large Passenger Aircraft
MFFD	MultiFunctional Fuselage Demonstrator
OML	Outer Mould Line
PEKK	PolyEtherKetoneKetone

XVI. JTI-CS2-2018-CfP09-LPA-02-28: Innovative tooling, end-effector development and industrialisation for welding of thermoplastic components

Type of action (RIA/IA/CSA):		IA	
Programme Area:		LPA	
(CS2 JTP 2015) WP Ref.:		WP 2.1.5	
Indicative Funding Topic Value (in k€):		1050	
Topic Leader:	Fokker	Type of Agreement:	Implementation Agreement
Duration of the action (in Months):	24	Indicative Start Date (at the earliest)³⁶:	Q3 2019

Topic Identification Code	Title
JTI-CS2-2018-CfP09-LPA-02-28	Innovative tooling, end-effector development and industrialisation for welding of thermoplastic components
Short description	
Automatic assembly of the fuselage demonstrator made of C/PEKK is a solution to achieve a high production rate at relatively low cost. This topic involves the development of: <ul style="list-style-type: none"> • Several robotic end-effectors to be used for jig-less assembly of the lower fuselage demonstrator • An innovative adaptive assembly tool to weld stringers and frames to the fuselage skin • 3D manufacturing simulations and dynamic workflow optimisation as part of Industry 4.0 aspects In addition a more transversal activity is necessary to study how to utilize the equipment in the most efficient manner and to contribute to a near “zero-defect” assembly process.	

Links to the Clean Sky 2 Programme High-level Objectives³⁷				
This topic is located in the demonstration area:		Cabin & Fuselage		
The outcome of the project will mainly contribute to the following conceptual aircraft/air transport type as presented in the scene setter:		Advanced Long-range Advanced Short/Medium-range		
With expected impacts related to the Programme high-level objectives:				
Reducing CO ₂ emissions	Reducing NO _x emissions	Reducing Noise emissions	Improving EU Competitiveness	Improving Mobility
<input type="checkbox"/>	<input type="checkbox"/>	<input type="checkbox"/>	<input checked="" type="checkbox"/>	<input type="checkbox"/>

³⁶ The start date corresponds to actual start date with all legal documents in place.

³⁷ For further info see Chapter 1 “Introduction to the Programme Scene Setter / Objectives” with key technology themes / demonstration areas. Detailed information available in the CS2 Development Plan accessible via the Clean Sky JU Website and EC Participant Portal.



1. Background

Large Passenger Aircraft (LPA) Platform 2 – Multifunctional Fuselage Demonstrator

The objective of Large Passenger Aircraft (LPA) Platform 2 – Multifunctional Fuselage Demonstrator (MFFD) is to validate high potential combinations of airframe structures, cabin/cargo, and system elements using advanced materials and applying innovative design principles in combination with the most advanced system architecture of the next generation fuselage and cabin.

The overall objectives of the MFFD are:

- Enable a high production rate of a minimum of 60 aircraft per month
- Achieve a total fuselage weight reduction of 1000kg
- Achieve a reduction of recurring costs

The driver of this approach is to attain a significant fuel burn reduction by substantially reducing the overall aircraft energy consumption, apply low weight systems and system architecture/integration and to be able to cash in weight potentials in the structural design of the fuselage and the connected airframe structure. This must be achieved by the development and application of industry 4.0 opportunities such as design for manufacturing & automation, automation, sensorization, and data analysis to demonstrate desired manufacturing cost effects.

WP2.1.5 Lower half of the Multifunctional Fuselage Demonstrator

Project activities started on the development of the lower half of the multifunctional fuselage demonstrator. This part of the project will develop, manufacture and deliver a 180° full scale multifunctional integrated thermoplastic (C/PEKK) lower fuselage shell, including cabin and cargo floor structure and relevant main interior and system elements. The demonstrator has a length of around 8 m, and a varying radius between 2 and 2.5 m, similar to an A321 lower fuselage.

The applicants work will involve key aspects of the activity on the MFFD. Figure 1 provides a view on the lower half fuselage module concept with some characteristic features highlighted. The lower fuselage module itself is divided into two main modules: the lower fuselage stiffened shell module and the passenger floor and cargo hold module.

Innovative tooling, end-effector development and industrialisation for welding of thermoplastic components

This call topic aims to contribute to the demonstration of high production rate readiness objective of the lower half of the Multi-Functional Fuselage Demonstrator (MFFD). In addition, cost reduction and derived objectives such as a zero-defect factory are important as well.

The specific aim of this call is to develop innovative tooling, end-effectors and industrialisation in the form of a digital twin for welded assembly of thermoplastic components. The innovative tooling will need to be developed for welding of stringers and frames onto the fuselage skin. The end-effectors can be divided into two categories: those used for welding and those used for pick and place operations. Industrialisation aspects of this call will be in the form of a digital twin and assembly flow and dynamic flow simulations. The simulations are needed to fully utilize the equipment and as such contribute to achieve the required production rate and reduced cost.

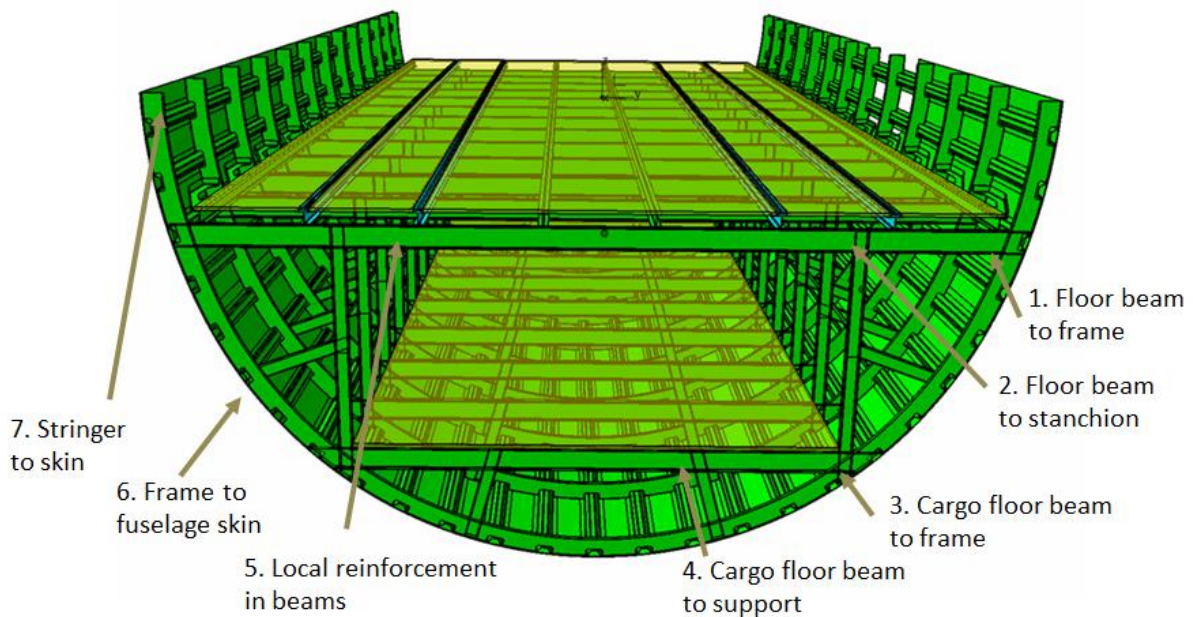

Figure 1: Overview of the Multifunctional Fuselage demonstrator lower half and welded joints

2. Scope of work

The scope of work is summarized in four main tasks as stated in the table below.

Tasks		
Ref. No.	Title - Description	Due Date
T1	End-effector development for jig-less assembly, 'pick and position' functionality	M15
T2	Innovative end-effector development for welding	M15
T3	Adaptive assembly tool for welding of stringer and frames	M15
T4	Manufacturing simulations	M21

T1 End-effector development for jig-less assembly, 'pick and position' functionality

Jig-less assembly is an innovative process based on the principle of assembly without dedicated tooling. Through using of more generic tooling rather than specific or dedicated tooling, cost can be reduced by up to 10% and flexibility will be increased. Fixed jigs are used in conventional assembly processes where the jig determines both the position and location of the assembly. One approach for jig-less assembly is to use fixtures which locate the assembly but do not determine the position of a feature like a jig does. In addition, a highly automated assembly process requires robotic end-effectors that are able to pick up a part from a storage area and place it at the correct position. The components that need to be welded as indicated in figure 1 are also the components that need to be used for this task.

T2 Innovative end-effector development for welding

Welding of thermoplastic composites allows for a reduction of assembly costs and time and offers benefits regarding dustless assembly of the multifunctional fuselage. Welding of thermoplastics involve application of sufficient pressure and heat. The successful applicant shall develop end-effectors that can apply the required pressure, which is between 5 and 7 bar. The pressure needs to be applied by the self-supporting end-effector, which implies that the end-effectors need dual sided access of the

components. The applicant is encouraged to develop innovative solutions for this particular topic as significant pressure needs to be applied with limited available space.

In addition, it is strongly desired to reduce the number of dedicated end-effectors and develop innovative solutions that may be adaptive and thereby allow for welding more than one configuration. Such a solution would be ideal for a jig-less assembly concept.

T3 Adaptive assembly tool for welding of stringer and frames to skin

The lower fuselage stiffened shell structure consists of a fuselage skin, stringers and frames that need to be welded together. Due to its size, jigless assembly is not deemed feasible, instead an adaptive assembly tool is needed to support the fuselage structure at its outer mould line. Welding pressure and heat will be applied from the inside with the adaptive assembly tool fulfilling the function of a backing structure. For the demonstrator, all components will be welded one by one with the stringers first and then the frames. With the main applied pressure loading in vertical direction, the mould would need to rotate around a central axis. This approach requires the assembly tool to be adaptive due to the curvature of the fuselage not being of a constant radius. Furthermore the applicant is encouraged to propose innovative solutions for positioning and maintaining position of the fuselage shell during the assembly process.

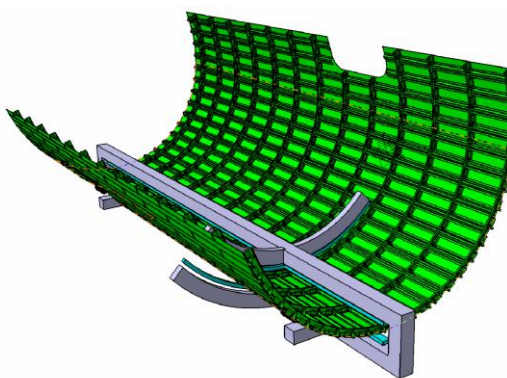

Figure 2: Impression of a stringer assembly weld tool

T4 Manufacturing simulations

In order to utilize the developed equipment in the most effective manner, advanced manufacturing simulations are needed. As such, this task can be regarded as a more transversal activity compared to the three other tasks. For a high production rate aircraft program, it is essential that any distortions to the line are minimized which results in an aim for a ‘zero defect’ manufacturing. The applicant is asked to develop such simulations and include aspects such as variation management studies, and failure mode and effect analysis. The simulations contribute to and are part of the development of a digital twin, which is also part of this task.

The first three tasks will need to be executed according to the typical phases: requirements definition phase, concept design phase, detailed design phase, and manufacturing phase. Once the end-effectors are delivered to the topic manager, the topic manager uses them to assemble the lower half of the multifunctional fuselage demonstrator.

The topic manager will be responsible for providing design details of the components and joints as indicated in figure 1. Furthermore, the Topic Manager will also be responsible for providing specific heating elements used for thermoplastic welding. The topic manager has access to a state of the art robotic assembly centre, which is planned to be used for demonstration of the hardware delivered by the applicant.

3. Major Deliverables/ Milestones and schedule (estimate)

*Type: R= Report, RM= Review Meeting, D=Data, HW=HardWare

Deliverables			
Ref. No.	Title - Description	Type*	Due Date
D1	Hardware requirements definition	R	M3
D2	Conceptual design of end-effectors and assembly tool (including CAD models)	R, D	M5
D3	Detail design of end-effectors and assembly tool (including CAD models)	R, D	M9
D4	Delivery of End-effectors, welding and 'pick and position'	HW	M15
D5	Delivery of assembly tool for stringers and frames to skin	HW	M15
D6	Dynamic Production Simulation Report (including simulation files)	R,D	M18
D7	FMEA risk scenario report	R	M20
D8	Delivery of a digital twin concept (including software files)	R, D	M22
D9	Final Evaluation report	R	M24

Milestones (when appropriate)			
Ref. No.	Title – Description	Type*	Due Date
M1	Kick-off meeting	RM	M1
M2	PDR of End-effector and assembly tool designs	RM	M5
M3	CDR of End-effector and assembly tool designs	RM	M9
M4	Delivery of End-effectors and assembly tool	HW	M15
M5	Manufacturing simulation review	RM	M16
M6	Final Evaluation review meeting	RM	M22

Gantt Chart for deliverables and Milestones

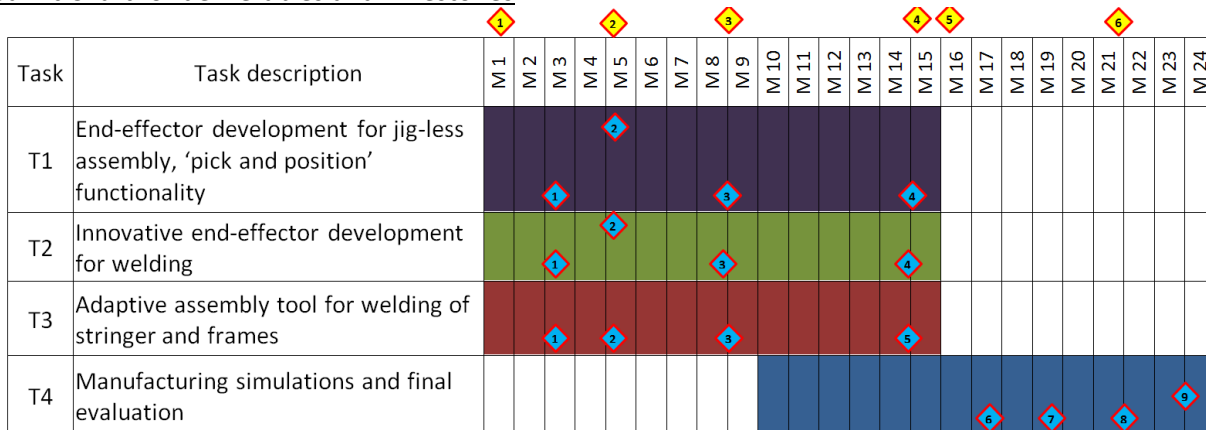

Deliverable  Milestone 

As can be seen in the GANNT chart, deliverables 1 to 5 are linked to tasks 1 to 3 whereas deliverables 6 to 9 are linked to task 4.



4. **Special skills, Capabilities, Certification expected from the Applicant(s)**

Special skills

- The applicant shall be able to demonstrate sound technical knowledge in the field of proposed contributions; the applicant shall be able to demonstrate that their knowledge is widely recognized.
- The applicant shall provide evidence to be able to cope with the required high level of adequate resources in qualified personnel, required tools and equipment.
- The activity will be managed with a Phase & Gate approach. The Topic Manager will approve gates toward subsequent phases.
- Demonstrated experience in management, coordination of development projects.
- Industrial Experience with tooling development.

Capabilities

- The applicant should have work-shop facilities in line with the proposed deliverables and associated activities or, if such equipment is not available, have existing relation with institutions or companies that accommodate such equipment.
- The applicant should have proven capabilities to do manufacturing simulations, and tooling design. Catia releases compatible to the Topic manager are required.

5. **Abbreviations**

CDR	Critical Design Review
FMEA	Failure Mode and Effect Analysis
LPA	Large Passenger Aircraft
MFFD	Multifunctional Fuselage Demonstrator
PDR	Preliminary Design Review

XVII. JTI-CS2-2018-CfP09-LPA-02-29: High performance gas expansion system for halon-free cargo hold fire suppression system

Type of action (RIA/IA/CSA):		IA	
Programme Area:		LPA	
(CS2 JTP 2015) WP Ref.:		WP 2.2.3.1	
Indicative Funding Topic Value (in k€):		700	
Topic Leader:	Airbus	Type of Agreement:	Implementation Agreement
Duration of the action (in Months):	24	Indicative Start Date (at the earliest)³⁸:	Q3 2019

Topic Identification Code	Title
JTI-CS2-2018-CfP09-LPA-02-29	High performance gas expansion system for halon-free cargo hold fire suppression system
Short description	
Design, develop, test, characterize, provide and operate a high performance inert gas expansion system demonstrator for halon-free cargo hold fire suppression system. The demonstrator shall store inert gas in a temperature range from -55°C to +85°C and expand the inert gas in a temperature range from -40°C to +70°C. The demonstrator shall discharge a constant high rate inert gas flow and a subsequent constant low rate gas flow for building up and maintaining an inert gas design concentration inside an airtight enclosure.	

Links to the Clean Sky 2 Programme High-level Objectives ³⁹				
This topic is located in the demonstration area:		Cabin & Fuselage		
The outcome of the project will mainly contribute to the following conceptual aircraft/air transport type as presented in the scene setter:		Advanced Long-range Ultra-advanced Long-range Advanced Short/Medium-range		
With expected impacts related to the Programme high-level objectives:				
Reducing CO ₂ emissions	Reducing NO _x emissions	Reducing Noise emissions	Improving EU Competitiveness	Improving Mobility
<input type="checkbox"/>	<input type="checkbox"/>	<input type="checkbox"/>	<input checked="" type="checkbox"/>	<input type="checkbox"/>

³⁸ The start date corresponds to actual start date with all legal documents in place.

³⁹ For further info see Chapter 1 “Introduction to the Programme Scene Setter / Objectives” with key technology themes / demonstration areas. Detailed information available in the CS2 Development Plan accessible via the Clean Sky JU Website and EC Participant Portal.

1. Background

The work to be performed is a building block for the development of an environmentally friendly and economically viable halon-free cargo hold fire suppression system.

The work is related to Regulation (EC) No 1005/2009 on substances that deplete the ozone layer (ref. also to https://ec.europa.eu/clima/events/evaluation-ozone-regulation_en).

The halon-free aviation fire suppression system market offers a huge business opportunity for the aeronautical industry and supply chain in Europe.

The high level objectives are closely linked to the Clean Sky 2 objectives:

- Reduction of environmental impact by replacing the ozone depleting Halon 1301
- Weight reduction and with this reduction of the aircrafts CO₂ and NO_x footprint

The main objective is the design, development, manufacturing and testing of a lightweight inert gas expansion system demonstrator allowing discharging a constant high flow followed by a subsequent low flow of inert gas under very challenging environmental conditions.

The intended function of the system is to flood a cargo hold with inert gas with a constant inert gas flow, independently of the pressure of the inert gas reservoir.

The temperature of the inert gas reservoir will range from -40°C to +70°C under normal operating conditions.

The demonstrator shall be integrated into the test facilities of the Fraunhofer Institute in Holzkirchen/Valley, Germany that will provide a unique test facility for a cargo hold fire suppression system. The test facility comprises a large low pressure chamber that contains an original forward fuselage section of an Airbus aircraft. The facility allows to create realistic flight conditions (cabin altitude conditions, descent profiles, etc) on ground. The demonstrator will be installed in a representative installation area of the fuselage allowing to perform Nitrogen discharge and hold time tests under representative environmental flight conditions.

The tasks to be performed comprise also the shipment and integration of the demonstrator into the Fraunhofer test facility and the subsequent safe operation of the demonstrator during the test campaign planned on grounds of the Fraunhofer Institute in Holzkirchen.

Work Breakdown Structure (WBS)

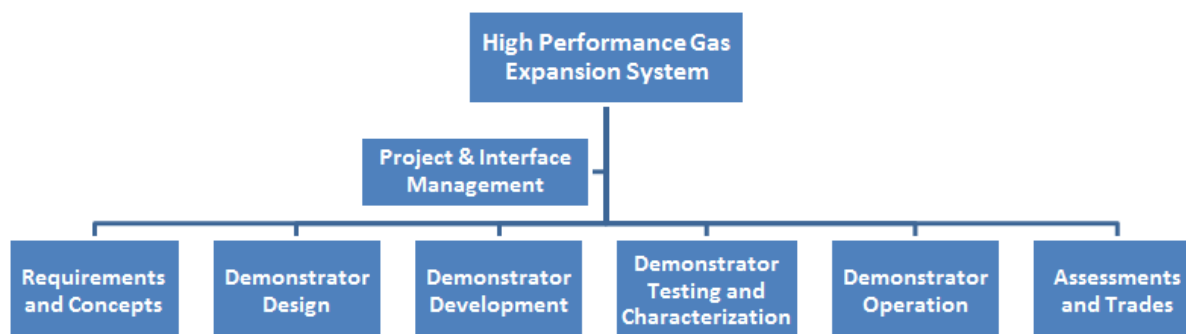

The following schematic illustrates the main components of the demonstrator. The demonstrator shall be equipped with all necessary safety means and with sensors allowing characterizing the static and transient conditions of the entire demonstrator system.

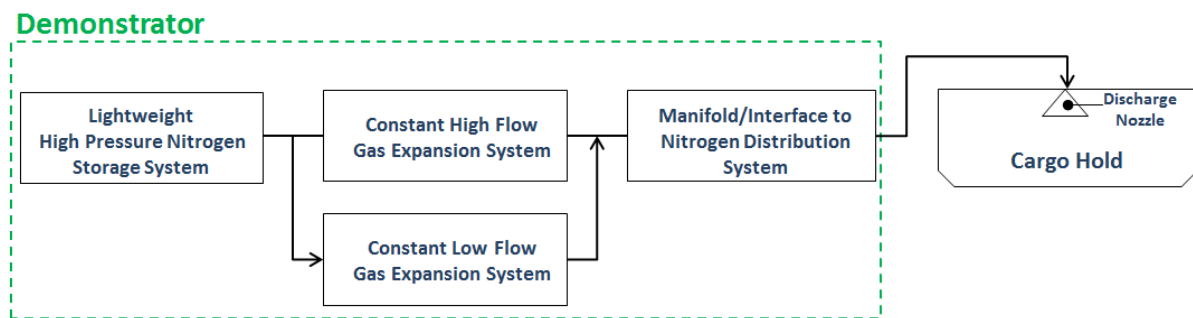

2. Scope of work

High level requirements and boundary conditions:

- The design of the demonstrator shall consider lightweight high pressure vessels
- Commercial off-the-shelf (COTS) lightweight high pressure vessels shall be considered for the design of the storage system for cost efficiency reasons.
- The design of the demonstrator shall consider the highest operational pressures allowable for the storage system according to standards accepted by the airworthiness authorities
- The demonstrator shall provide a constant high flow of inert gas during the high-rate gas discharge phase taking into account the specific operational temperature envelope in which a later system must operate
- The demonstrator shall provide a constant low flow of inert gas during low-rate gas discharge phase taking into account the specific operational temperature envelope in which a later system must operate
- The constant high flow of inert gas shall be in a range of 230g/s to 350g/s – the constant low flow of inert gas shall be in a range of 10g/s to 30g/s. The exact values will be specified and agreed within the scope of the requirements capture phase.
- The demonstrator design shall prevent pressure peaks during the high-rate gas discharge phase
- The demonstrator design shall include safety features allowing a safe operation of the demonstrator
- The demonstrator design shall include instrumentation allowing to monitor, measure and characterize the static and transient conditions of the entire demonstrator unit (e.g. bottle pressure, pipe pressure, gas discharge behavior over the specified temperature range, etc).
- The demonstrator design shall include features allowing to recharge the gas storage system at the test premises

The tasks to be performed for this topic are described in the following table.

Tasks		
Ref. No.	Title - Description	Due Date
1.0	Demonstrator Design	Q1-2020
1.1	Capture, analyze, trace, validate and verify requirements	Q4-2019
1.2	Design and specify system, subsystems and components and their interfaces	Q1-2020
2.0	Demonstrator Manufacturing	Q3-2020
2.1	Procure and/or manufacture equipment and subassemblies necessary for setting up the demonstrator unit	Q1-2020

Tasks		
Ref. No.	Title - Description	Due Date
2.2	Set up and assemble the demonstrator unit	Q3-2020
3.0	Demonstrator Testing and Characterization	Q1-2021
3.1	Perform all necessary and required tests that ensures the subsequent safe use and safe operation of the demonstrator at test benches that are located at external premises	Q4-2020
3.2	Characterize the gas expansion behavior of the demonstrator for a temperature range between -40°C and +70°C	Q1-2021
4.0	Demonstrator Integration and Operation	Q2-2021
4.1	Provide and ship the demonstrator to external test benches	Q1-2021
4.2	Operate the demonstrator at external test benches	Q2-2021
5.0	Assessments, Evaluation and Trades	Q3-2021
5.1	Perform and provide a preliminary opportunity and risk study	Q1-2020
5.2	Perform and provide a preliminary Safety and Reliability assessment	Q2-2020
5.3	Perform and provide an opportunity and risk study	Q3-2021

The following sections give a more detailed description of the tasks to be performed.

Task 1 – Demonstrator design

- Clarify, derive and define main requirements; define overall system boundaries and main interfaces
- Develop and down-select concepts, select final concept for the high performance gas expansion system
- Design and specify system, subsystems and components and their interfaces
- Design and compile a control & indication concept
- Provide design limitations
- Provide hydraulic calculations for the distribution piping

Task 2 – Demonstrator manufacturing

- Procure and/or manufacture equipment and subassemblies necessary for demonstrator development
- Manufacture and build the demonstrator - set up the necessary testing infrastructure

Task 3 – Demonstrator testing and characterization

- Perform all necessary and required tests that will allow the subsequent use and safe operation of the demonstrator at external test benches
- Characterize the gas expansion behavior of the demonstrator for different temperatures and pressures
- Provide gas flow characteristic in dependency of different storage pressures vs time for the high-rate gas discharge phase and for the low-rate gas discharge phase

Task 4 – Demonstrator integration and operation

- Provide the demonstrator and ship it to the Fraunhofer test facility in Holzkirchen, Germany
- Provide necessary information, equipment and personal allowing to integrate and operate the demonstrator at the Fraunhofer test facility
- Operate the demonstrator during test campaign at Fraunhofer test facility

Task 5 – Assessment, evaluation and trades

- Perform a risk and opportunity analysis and provide a risk and opportunity register - including maintenance aspects and (street) transportation aspects
- Compile and provide a trade between a system incorporating DOT qualified cylinder and ISO qualified cylinder
- Perform a preliminary system safety assessment - compile and provide first projected reliability and safety figures
- Compile and provide a first plan for the industrialization of the concept highlighting risks, gaps and opportunities

3. Major Deliverables/ Milestones and schedule (estimate)

*Types: R=Report, D-Data, HW=Hardware

Deliverables			
Ref. No.	Title - Description	Type*	Due Date
D1	Requirements Collection Document	R	Q4-2019
D2	System Description Document – Demonstrator Design	R	Q1-2020
D3	Preliminary Safety and Reliability Assessment	R	Q2-2020
D4	Hydraulic Calculations	R	Q3-2020
D5	Discharge Characteristics	R	Q4-2020
D6	Proof- and Burst Pressure Test Results	R	Q4-2020
D7	Demonstrator	HW	Q1-2021
D8	Final Project Report	R	Q3-2021

Milestones (when appropriate)			
Ref. No.	Title - Description	Type*	Due Date
1	Kick-off Meeting	R	Q3-2019
2	Requirements capture and analysis completed	R	Q4-2019
3	Preliminary demonstrator design available	R	Q1-2020
4	Design review meeting	R	Q1-2020
5	Demonstrator design finalized	R	Q1-2020
6	Test program specified	R	Q2-2020
7	Test plan review meeting	R	Q2-2020
8	Demonstrator equipment and subassemblies available	HW	Q3-2020
9	Demonstrator hardware available and ready for test	HW	Q3-2020
10	Test benches available	HW	Q3-2020
11	Proof and Burst pressure tests completed	D	Q4-2020
12	Gas expansion and discharge tests completed	D	Q4-2020
13	Demonstrator/Lab Unit Acceptance Review Meeting	R	Q1-2021
14	Demonstrator hardware available at V&V test bench	HW	Q1-2021
15	Demonstrator integration into V&V test bed completed	D	Q1-2021
16	Test campaign completed	D	Q2-2021
17	Test report compiled	R	Q3-2021
18	Final review meeting	R	Q3-2021
19	Closure	R	Q3-2021

Tentative High Level Roadmap

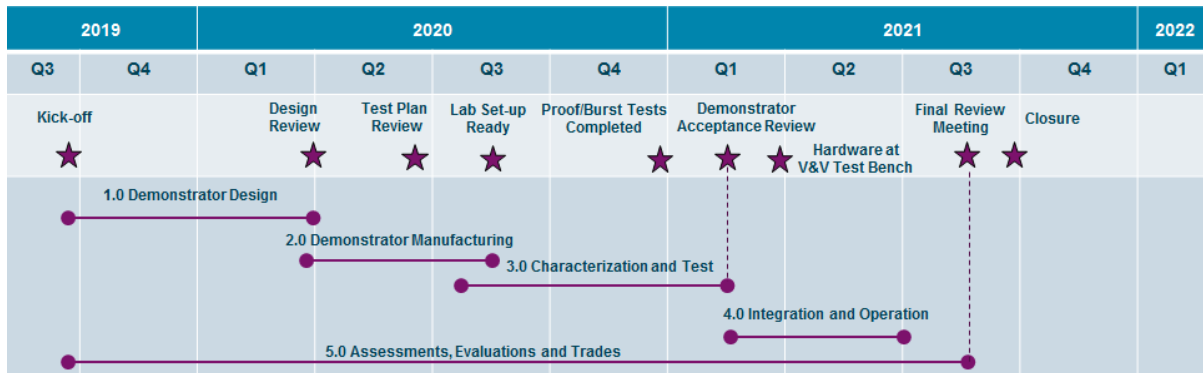

4. Special skills, Capabilities, Certification expected from the Applicant(s)

- The applicant shall demonstrate its capability to design, manufacture, test and operate high pressure gas systems
- The applicant shall have capabilities or shall have access to facilities allowing to perform tests
- The applicant shall have capabilities or shall have access to facilities allowing to perform proof pressure tests and burst pressure that will be required to demonstrate a safe system operation under operational conditions.
- The applicant shall have an aerospace industry background, experiences and capabilities in:
 - Aircraft fire suppression systems
 - Pneumatic systems, regulators and valves
 - High pressure vessels design and associated standards accepted by the airworthiness authorities
 - Shipping regulations, maintenance standards and MRO processes for high pressure vessels
 - Test benches & procedures
 - Safety Engineering (PSSA/FMEA)
 - Airworthiness requirements
 - Industrialization capability

5. Abbreviations

DOT	Department of Transportation
FMEA	Failure Mode and Effects Analysis
HW	Hardware
ISO	International Organization for Standardization
MRO	Maintenance, Repair and Operation
N/A	Not Applicable
PSSA	Preliminary System Safety Analysis
V&V	Validation and Verification

XVIII. JTI-CS2-2018-CfP09-LPA-03-16: Automated data collection and semi-supervised processing framework for deep learning

Type of action (RIA/IA/CSA):		IA	
Programme Area:		LPA	
(CS2 JTP 2015) WP Ref.:		WP 3.1.4.7	
Indicative Funding Topic Value (in k€):		800	
Topic Leader:	Honeywell	Type of Agreement:	Implementation Agreement
Duration of the action (in Months):	24	Indicative Start Date (at the earliest)⁴⁰:	Q3 2019

Topic Identification Code	Title
JTI-CS2-2018-CfP09-LPA-03-16	Automated data collection and semi-supervised processing framework for deep learning
Short description	
The aim is to develop infrastructure for automated collection of big data and implement a framework that allows efficient processing, segmentation and annotation of this data for deep learning methods. The primary use case is VHF (very high frequency) radio communication and transcription, annotation and processing of recorded data.	

Links to the Clean Sky 2 Programme High-level Objectives⁴¹				
This topic is located in the demonstration area:		Enabling Technologies		
The outcome of the project will mainly contribute to the following conceptual aircraft/air transport type as presented in the scene setter:		Advanced Long-range Ultra-advanced Long-range Advanced Short/Medium-range Ultra-advanced Short/Medium-range		
With expected impacts related to the Programme high-level objectives:				
Reducing CO₂ emissions	Reducing NO_x emissions	Reducing Noise emissions	Improving EU Competitiveness	Improving Mobility
<input type="checkbox"/>	<input type="checkbox"/>	<input type="checkbox"/>	<input checked="" type="checkbox"/>	<input type="checkbox"/>

⁴⁰ The start date corresponds to actual start date with all legal documents in place.

⁴¹ For further info see Chapter 1 “Introduction to the Programme Scene Setter / Objectives” with key technology themes / demonstration areas. Detailed information available in the CS2 Development Plan accessible via the Clean Sky JU Website and EC Participant Portal.



1. Background

Introduction of technologies based on machine learning (ML) and artificial intelligence (AI) principles requires large amounts of data for robust performance as well as for validation and verification. The data collection, annotation and validation represents significant effort. This effort can be distributed among more entities with vested interest, who can then benefit from the access to the whole volume of transcribed and annotated data. Such pre-processed data can be used for further research, training of new models or for validation of freshly introduced products.

The topic was inspired by already existing practice in Open Source world, where the concept of community based contribution or crowd sourcing was proven to be successful, self-sustainable and efficient in many areas like software (Linux, Libre Office...), hardware (Arduino, Openmoko, LEON, RepRap...), digital content (Wikipedia, Unity Warehouse, Project Guttenberg,) and many others.

The topic shall develop a concept for operation of such community based solution, propose, design, develop and deploy an innovative platform for distributed data collection, annotation and validation of collected data and launch the platform on public.

The platform shall be easily accessible online using existing technologies, shall allow user access restrictions based on policies defined in the concept and follow existing EU legislation related to user privacy and data management. It shall be also secured against cyber-attacks.

There are two main innovative elements in this topic:

1. It is the semi-automatic transcription using latest machine learning and semi-supervised transcription methods. This shall significantly reduce the required effort for data processing and annotation and speed up the whole process.
2. It is the community driven, self-sustainable platform. The topic aims at creating a network of contributors, bring them benefits why to use this platform (e.g. access to the data, statistics, etc.) and motivate them to grow the area for data acquisition.

The scope of the call comprises multiple areas of expertise and domain knowledge hence a partner with broad portfolio or consortium of universities and SMEs is required to cover the full expected scope. The advantage of this topic is that it shall be open also for other use cases where annotated data are required. This opens new ways for future exploitation of this Topic. The annotation framework, available data and the active community can be interested not only for the Topic applicant(s), but also for the member of the contributing community - individual students, scientists and researchers, small enterprises, startups or large research institutes from other sectors.

2. Scope of work

The applicant shall develop:

- an infrastructure for automated collection of big data and
- implement a framework that allows efficient (semi-supervised and partially automated) processing, segmentation and annotation of this data for deep learning methods.

The primary use case for this call is transcription and annotation of recorded VHF radio communication from various geographical regions where distinct English accents of non-native English speakers can be expected (for example Roman, Slavic and Anglo-Saxon countries). However, the framework is expected to be configurable and support also the annotation of other kinds of data like biophysiological data, 3D spatial data or weather data that can be used for the use case of pilot state classification, object detection or aircraft trajectory optimization and fuel burn reduction.

The structure and main outcomes of this call shall be as follows:

- WP1: Live and active network of contributors (data providers, transcribers, annotators)
The annotation of large amount of voice and/or other data represents tremendous volume of effort. The trend in other businesses is to join forces, involve a number of contributors and share the volume of the effort and jointly benefit from the access to results as a community. The expected content of this work package shall be:
 - Operational concept for the community (key persons, roles, activities, access to data, access to services, support of other community based projects – simulation platforms, Air Traffic Control (ATC) live, language training, phraseology etc.).
 - Key deliverable – “Community Launch strategy” document.
 - Activation of community of volunteers/contractors willing to help with data pre-processing.
 - Key deliverables: Public relations (PR) strategy description, Active group of supporters/contributors – need to define minimum size/other parameters.
 - “Gamification concept”– the members of the community can develop their “credit” in community based on the volume and quality of their contribution and/or other parameters. The processes for quality assurance has to be defined, inspiration by other community projects (SW, HW, digital content) is highly recommended.
 - Newcomers – minor contribution, must be reviewed by members with higher status before acceptance. (promotion is connected to volume x quality metrics)
 - Most senior (solid contributors) – can influence the future of community
 - Key deliverable – “Contributor incentive concept proposal” implementable into the future data collection platform
- WP2: Framework for data collection and annotation (storage, delivery process, preprocessing, etc.).
The collaborative space for the community of contributors. This work package shall define and develop online platform for efficient collaboration. The platform shall use available online environment (for example utilize existing cloud services), provide scalable storage space, define scalable workflows, user management, authentications and authorisation schemes, shall be compliant with existing legislative regarding privacy and data management. The work package shall deliver:
 - Jointly with Topic Manager define the processes, data flows and control means for efficient facilitation of data collection and annotation activities.
 - Design, development, implementation, validation and deployment of online collaborative environment facilitating the workflow
 - Key deliverables – System description, running instance of “community portal”, implemented data collection framework (data storage, cloud services, scripts, etc.)
- WP3: Toolset for innovative data annotation and processing
This work package shall develop the toolset for more effective and efficient data preprocessing and semi-supervised annotation. To accelerate the processing of raw data, some tools can pre-process them and thus reduce the volume which will remain for manual processing. Due to the variable character of modalities considered (speech, image, EEG, etc.), the main effort should be focused on developing generalized, yet efficient unsupervised and semi supervised methods on the back-end level. The methods can be designed using probabilistic, graph-based or deep network algorithms. However, the computational complexity and result interpretability should be taken into account when deciding on a particular algorithm. From the front-end point of view, it is expected to design and implement domain-independent methods, for example based on morphology, for dimensionality reduction and data structuring compatible with the proposed algorithms within the back-end part. These methods can have a supportive role to existing domain-dependent features or act as the only predictor. The work package shall deliver:
 - Concept, design and implementation of the methods for semi-automated data annotation

and validation

- Key deliverable – working set of tools tested by Topic Manager on agreed set of validation scenarios

WP4: Application for the data annotation and processing

Building on the toolset in WP3, develop an application able to run in the collaborative space (defined in WP2) and continuously process the collected data with incrementally increasing performance. The application is expected to follow current user experience and usability standards. The work package shall deliver:

- Implementation, validation and deployment of the concept into the existing community framework
- Key deliverable – application integrated into the proposed framework, able to provide raw and semi-supervised annotation of data with confidence intervals.

WP5: Legal framework

The topic needs to take into account evolving legislation addressing privacy, data management, data security and other aspects related to storage, processing and provisioning of large volumes of information in the cyberspace. The work package shall provide:

- Study of current legislation and regulations, constraints and key differences in EU member states (or out of EU).
- Study and guidelines for personal data protection (GDPR).
- Ethical issues considerations
- Guidelines for development of virtual collaborative environment
- Intellectual property policies (what belongs to whom, who will have access to the results, how results can be used, etc.)
- Key deliverable – study and report of legislative framework

Tasks		
Ref. No.	Title – Description	Due Date
Task 1	Data collection and classification community setup	T0+24
Task 2	Framework for data collection and annotation	T0+18
Task 3	Toolset for innovative data annotation and processing	T0+15
Task 4	Application for data annotation and processing	T0+15
Task 5	Legislative framework study	T0+9

3. Major deliverables/ Milestones and schedule (estimate)

*Type: R: Report, RM: Review Meeting, D: Delivery of hardware/software, M: Milestone

Deliverables			
Ref. No.	Title – Description	Type*	Due Date
D1	Community launch strategy	R	T0+6
D2	Validated platform for data collection and annotation	D	T0+18
D3	Toolset for data collection, annotation and validation	D	T0+15
D4	Application for data annotation and processing	D	T0+15
D5	Legislative framework study	R	T0+9

Milestones (when appropriate)			
Ref. No.	Title – Description	Type	
M1	build active network	R	
M2	framework for data collection	R	
M3	innovative annotation toolset	R	
M4	application for data annotation	R	
M5	Legal framework	R	

SCHEDULE (graphic)

Activity	T0	T0+3	T0+6	T0+9	T0+12	T0+15	T0+18	T0+21	T0+24
Build active network									
Framework for data collection									
Innovative annotation toolset									
Application for data annotation									
Legal framework									

4. Special skills, Capabilities, Certification expected from the Applicant(s)

The scope of the call embraces multiple expertise and capabilities required for the successful completion of the call objectives. The expected applicant is ideally a consortium of partners or a partner with broad portfolio of competences comprising:

- Expertize in machine learning and artificial intelligence. This partner is expected to develop the innovative toolset for more effective and efficient data processing and annotation.
- Experience in data acquisition and storing, strong in legal aspects, personal data processing and regulations.
- Excellent project management and leadership skills for building and managing the community of contributors.
- Solid big data expertise, excellent skills in software development and implementation of robust network solutions.

XIX. JTI-CS2-2018-CfP09-LPA-03-17: Audio Communication Manager for Disruptive Cockpit demonstrator

Type of action (RIA/IA/CSA):		IA	
Programme Area:		LPA	
(CS2 JTP 2015) WP Ref.:		WP 3.2	
Indicative Funding Topic Value (in k€):		700	
Topic Leader:	Airbus	Type of Agreement:	Implementation Agreement
Duration of the action (in Months):	48	Indicative Start Date (at the earliest)⁴²:	Q3 2019

Topic Identification Code	Title
JTI-CS2-2018-CfP09-LPA-03-17	Audio Communication Manager for Disruptive Cockpit demonstrator
Short description	
<p>In the frame of Disruptive Cockpit concept, the goal is to develop an Integrated Modular Avionics (IMA) application to manage the voice and data communications between the flight crew in the DISCO cockpit and the Ground via communication means (Legacy and/or Software Defined Radio based). The purpose is to alleviate the crew workload, when addressing simultaneously different ground operators, by removing the need of RMP (Radio Management Panel) and AMU (Audio Management Panel) and interfacing with innovative flight crew interface.</p> <p>This application will be hosted on the Topic Manager's Platform on the Large Aircraft disruptive Cockpit systems demonstrator.</p>	

Links to the Clean Sky 2 Programme High-level Objectives⁴³				
This topic is located in the demonstration area:		Next generation cockpit systems and operations		
The outcome of the project will mainly contribute to the following conceptual aircraft/air transport type as presented in the scene setter:		Advanced Long-range Ultra-advanced Long-range Advanced Short/Medium-range Ultra-advanced Short/Medium-range		
With expected impacts related to the Programme high-level objectives:				
Reducing CO₂ emissions	Reducing NO_x emissions	Reducing Noise emissions	Improving EU Competitiveness	Improving Mobility
<input type="checkbox"/>	<input type="checkbox"/>	<input type="checkbox"/>	<input checked="" type="checkbox"/>	<input type="checkbox"/>

⁴² The start date corresponds to actual start date with all legal documents in place.

⁴³ For further info see Chapter 1 "Introduction to the Programme Scene Setter / Objectives" with key technology themes / demonstration areas. Detailed information available in the CS2 Development Plan accessible via the Clean Sky JU Website and EC Participant Portal.



1. Background

Audio Suite aims at providing technical flight crew control of VOICE communications inside and outside A/C perimeter area and also to select Communication means mode (Voice or Datalink).

The basic functions of the Audio System installed on the Airbus aircrafts are:

- Frequency / Modes / Phone number control and display for the Radio Communication systems
- Management of the tuning / dialing function
- Frequency / Channel / Course control and display for the Radio Navigation systems, as a standby mode in case of FMS failure
- Passenger address function
- Ground crew and cabin attendant call indications
- Cabin interphone management
- Audio control of the radio communication & radio navigation systems
- Aural warning function (participation to the global audio warnings function through AMU audio amplification function)
- SelCal function
- Voice encoding and control function
- Flight interphone management
- Management of the datalink router and providers (settings, communications status display and parameters display)

The voice frequency selection is performed by the pilot based on the defined flight plan and then by ATC center request.

It is basically composed of Audio Management Unit located in eBay and Radio Management Panel installed in Cockpit.

These LRUs are today connected to the communication means and others (surveillance, cabin,...) through differential lines, sharing only analogic audio information.

Future interfaced means are going into full digital world bringing the opportunity to study feasibility of a full digital audio concept (End to end between operator in cockpit up to Radio Baseband – see next § for Software Defined Radio concept presentation).

The goal of this call topic is then to explore and evaluate the implementation in real conditions of an application performing the audio communication routing function.

2. Scope of work

The objective of this Call topic for Partner is to define relevant requirements and to develop an application hosted on avionic platform to be used mainly for Communications means in current and future Aircraft Operational needs.

Innovative functions:

- Possible autonomous frequency selection
 - Dynamic and contextual frequency selection



- Interface with Speech To Text function
 - Digital audio management
 - Compatibility with multi modal Human Machine Interface

Possible autonomous frequency selection

Use of below function can allow an autonomous frequency selection to alleviate crew workload

Dynamic and contextual frequency selection

Application will be able to propose the relevant frequency to the pilot depending on Aircraft position and Flight Phase.

Interface with Speech To Text function

Function allowing automatic frequency identification provided by ATC centercentre

Digital audio management

Function to route digital audio signal and manage dynamically equipment availability (out of range or failure management)

Compatibility with multi modal Human Machine Interface

This application will enable integration of audio into future Disruptive Cockpit environment

Based on the operational concept and system specification provided by Airbus, the partner activities will cover:

- Software architecture definition,
- Interface specification,
- System prototype development,
- Integration support to ground testing,
- Global V&V and performance assessment.

2 steps need to be considered for the Call:

- Phase 1 for TRL 5 in 2021
- Phase 2 upon decision gate for TRL6 maturity by end of the project in 2023.

A decision gate (DG) will be performed by end of Phase 1 to ensure that selected architecture will fit the needs of Disruptive Cockpit demonstrator and overall future architecture. Way forward of this DG will be a Go/No Go decision for TRL6 demonstration or potentially to orient second prototype definition into the appropriate future audio architecture. In case of a re-orientation of the concept during the second phase, a decrease of prototype maturity could be discussed to ensure schedule adherence.

Airbus is leading Work Package 3.2 dedicated to Software Defined Radio. This WP will be used as an input for Communication means (VHF and SATCOM in a first step)

Information will be received from the Cockpit using AFDX information. They are composed of at least digital audio signals, mean selection and tuning information (Signal characteristics will be provided within Airbus specification).

Framework at AEEC is currently running with Communication, Navigation and Surveillance actors in

order to find a consensus on Standardization needs. Interfaces with Audio Communication Manager will be addressed within this framework and will have to use outcome standard.

Partner will have to provide application developed using ARINC 653 capable to route digital information coming from ACPs (Audio Control Panel) toward relevant means. Expected mean and applicable function will be received from Cockpit in dedicated VLs.

This application will be flexible enough to support new communication means without necessary redesign.

Global bench logical architecture is provided below – not exhaustive in term of communications means and other interfaces.

Relevant Application is shown in Orange below:

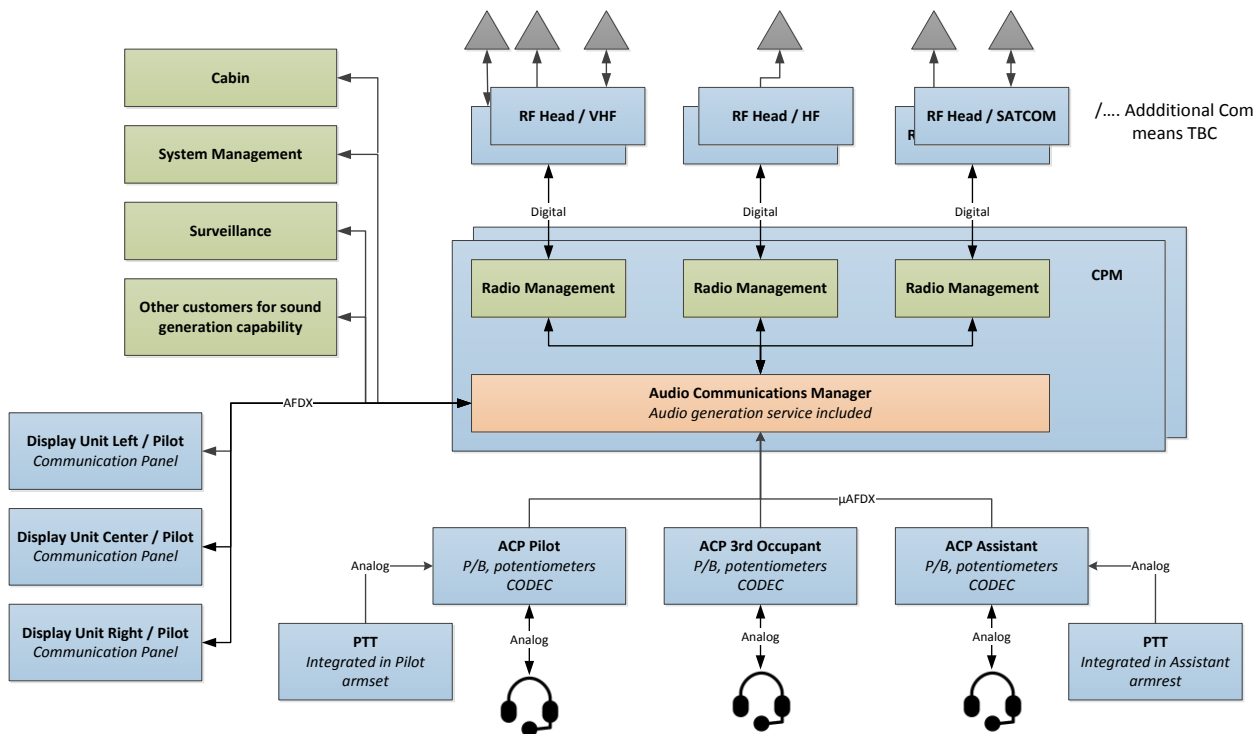

The final architecture is not yet frozen:

- It is thus considered that Radio communication means will be hosted on several CPMs (Core processing modules) for redundancy aspects,
- Reconfiguration between CPMs should be considered in order to be CPM fault tolerant,
- Digital audio CODECs are not defined yet,
- Current network to be envisaged is AFDX without time stamping and synchronization capacity, potential introduction of TSN protocol or data centric function is to be further studied
- Capacity to route audio signal toward a Speech to system/text function shall be considered

Audio characteristics can be discussed with partner during the Airbus specification.

The following necessary design features will be detailed in the airframer specification to be provided at



the initiation of the project:

- Degraded mode identification and reconfiguration patterns
- Data security architecture requirements and design constraints
- Disruptive Cockpit Demonstration prototype integration requirements and interfaces

The expected contribution from the applicant consists in:

- a) Supporting the requirements definition at system level based upon requirements provided by the aircraft manufacturer
- b) Defining audio routing system based upon system architecture concept provided by the A/C manufacturer
- c) Providing system architecture and application software models to support Model Based Systems Engineering (will be confirmed for KOM), and supporting Virtual testing with Model In the Loop (MIL) and Software in the loop (SIL)
- d) Building & testing prototypes for concept validation, operational and performance verification on applicant facilities, interfacing with A/C systems models to be provided by the A/C manufacturer
- e) Support Airbus the Topic Manager during the integration, tests and validation of the prototypes on the Topic Manager's Airbus simulator tests platform.

Solutions shall be compliant with the ATM Masterplan.

At project execution level, where applicable, interaction with SESAR will be implemented and sharing of results will be pursued.

Tasks		
Ref. No.	Title – Description	Due Date
Task 1	Definition of requirements - Requirements shall be defined at System and equipment level to support the scenario of A/C communication.	T0+6Mo
Task 2	Audio Concept definition – System and components concept shall be defined to support the defined requirements State of the art and review of available technologies. Definition of potential solutions for: System architecture Degraded mode identification	T0+7Mo
Task 3	Prototype modelisation – The proposed product shall be modelised through MBSE agreed tool	T0+7Mo
Task 4	Application prototyping – The proposed product shall be defined and verified: Building of prototypes Verification test and analysis of the selected solution in partner facility	T0+12Mo
Task 5	Prototype Integration – Prototype shall be integrated on Platform3 System demonstrator by the partner to ensure proper concordance with cockpit systems (Displays/ACP) and communication means (VHF/SATCOM)	T0+13Mo
Task 6	Support to Airbus the Topic Manager - during the tests and validation of the Airbus Disco concept	--
Task 7	Final Phase 1 Report showing TRL5 maturity and Phase 2 Decision Gate support– All results shall be formalized in the final report.	T0+24Mo

Tasks		
Ref. No.	Title – Description	Due Date
Task 8	If relevant for TRL6 definition: Requirements shall be refined at System and equipment level to support the scenario of A/C communication MBSE model shall be updated	T0+27Mo
Task 9	If relevant for TRL6 definition: Prototype definition shall be updated TRL6 prototype shall be integrated on Disco bench Support to Airbus the Topic Manager upon request	T0+32Mo
Task 10	TRL6 Maturity demonstration	T0+48Mo

3. Major Deliverables/ Milestones and schedule (estimate)

Deliverables			
Ref. No.	Title – Description	Type	Due Date
D1	Partner System Specification – Compilation of relevant requirements.	Document	T0+6Mo
D2	Prototype Compliance Matrix – Compliance to prototype against requirements and propose degraded mode	Document	T0+12Mo
D3	TRL5 MBSE model	model	T0+7Mo
D4	Full function, fully verified prototype (TRL5)	Prototype	T0+12Mo
D5	TRL5 System Validation & verification Report – Compilation of evidences from the validation, verification & integration process.	Document	T0+16Mo
D6	TRL5 maturity assessment report	Report	T0+24Mo
D7	TRL6 MBSE model	model	T0+27Mo
D8	Full function, fully verified prototype (TRL6)	Prototype	T0+32Mo
D9	TRL6 System Validation & verification Report – Compilation of evidences from the validation, verification & integration process.	Document	T0+38Mo
D10	TRL6 maturity assessment report	Report	T0+48Mo

Milestones			
Ref. No.	Title – Description	Type	Due Date
DR	Design Review Review of the trade-offs, definition of the system architecture to be tested.	Review	T0+7Mo
IRR	Integration Readiness Review Review of the prototypes to be tested	Review	T0+12Mo
DG	Decision Gate (Maturity Assessment Review TRL5)	Review	T0+24Mo
DR2	Design Review TRL6 Review of the trade-offs, definition of the system architecture to be tested.	Review	T0+27Mo



Milestones			
Ref. No.	Title – Description	Type	Due Date
IRR2	Integration Readiness Review TRL6 Review of the prototypes to be tested	Review	T0+32Mo
MAR	Maturity Assessment Review TRL6	Review	T0+48Mo

4. **Special skills, Capabilities, Certification expected from the Applicant(s)**

Following skills and capabilities are expected from the Applicant:

- Long experience and high skills in the design and manufacture of audio systems for the aerospace industry.
- Knowledge and experience of ARINC 653 development.
- Knowledge and experience in Communications means that are interfaced to Audio Communication means
- Capacity to develop Software Build using Aeronautics standards
- Knowledge and experience in Aircraft bench integration

5. **Abbreviations**

A/C	Aircraft
ACP	Audio Communication Panel
ATC	Air Traffic Center
FMS	Flight Management System
MBSE	Model Based System Engineering
SATCOM	SATellite COMmunication
TRL	Technology Readiness Level
VHF	Very High Frequency

XX. JTI-CS2-2018-CfP09-LPA-03-18: Safe emergency trajectory generator

Type of action (RIA/IA/CSA):		IA	
Programme Area:		LPA	
(CS2 JTP 2015) WP Ref.:		WP 3.5	
Indicative Funding Topic Value (in k€):		1000	
Topic Leader:	Thales Avionics	Type of Agreement:	Implementation Agreement
Duration of the action (in Months):	36	Indicative Start Date (at the earliest)⁴⁴:	Q3 2019

Topic Identification Code	Title
JTI-CS2-2018-CfP09-LPA-03-18	Safe emergency trajectory generator
Short description	
The objective is to assess the feasibility of a new on-board function for flight management. More precisely, the aim of the project is to design an emergency landing site and trajectory generating function for commercial aircraft allowing a safer return to ground when normal operation is interrupted, in the context of future automated operations with reduced crew.	

Links to the Clean Sky 2 Programme High-level Objectives⁴⁵				
This topic is located in the demonstration area:		Cockpit & Avionics		
The outcome of the project will mainly contribute to the following conceptual aircraft/air transport type as presented in the scene setter:		Advanced Long-range Advanced Short/Medium-range		
With expected impacts related to the Programme high-level objectives:				
Reducing CO₂ emissions	Reducing NO_x emissions	Reducing Noise emissions	Improving EU Competitiveness	Improving Mobility
<input type="checkbox"/>	<input type="checkbox"/>	<input type="checkbox"/>	<input checked="" type="checkbox"/>	<input type="checkbox"/>

⁴⁴ The start date corresponds to actual start date with all legal documents in place.

⁴⁵ For further info see Chapter 1 “Introduction to the Programme Scene Setter / Objectives” with key technology themes / demonstration areas. Detailed information available in the CS2 Development Plan accessible via the Clean Sky JU Website and EC Participant Portal.



1. Background

The primary objective pursued here is to help improve safety of flight in the frame of reduced crew operations.

Different circumstances can lead an aircraft to enter a safety critical state. Depending on the kind of failure experienced, various mitigation procedures can be undertaken:

- a) diversion towards a new destination, known in advance, while the flight control systems are fault free,
- b) abnormal situations or important failures with partial failure of flight systems, requiring urgent landing, although unprepared.

Reduced crew operations call for highly automated trajectory generation upon failure occurrence in novel situations such as case ii) above (i.e. the Hudson case).

While some of the failure situations can be tackled rather adequately by existing flight systems (in general through the Flight Management System which has the ability to follow new flight plans for an unpaired aircraft and the auto-guidance system which make possible to perform them), others lead to novel situations where the crew has to find a solution with a variable outcome. Hence, automated trajectory planning must be a core component of any extended flight management system designed in this new context.

Using a database of possible landing sites, meteorological information gathered from a system-wide network, the flight planning will issue a safe or best effort emergency flight path that is primarily intended to be tracked by the standard flight management system (FMS).

To deal with possible errors including the failure of the trajectory tracker, planned manoeuvres have to be kept human-aware, and not too complicated to be completed by a pilot.

An important factor that has to be considered during trajectory generation is the associated risk level. It can be split according to the different flight phases: en route, approach, landing.

The main risk factors for the en route phase towards a chosen landing site are: the remaining controllability of the aircraft, the propagation of the deterioration to other flight systems, a limited range and endurance (site reachability in terms of distance and time), the complexity of the trajectory to be performed (turns, speed changes) in the light of the actual flight performance of the aircraft, atmospheric conditions along the planned path (winds, turbulence,...), landing site adequacy and accessibility. During approach, the aircraft flies at low altitude towards the landing site and additional risk factors appear: visibility, urban premises along the approach trajectory, weather conditions.

Finally, a risk is associated with landing at a given site which corresponds to the availability of emergency facilities at this site or in the immediate surrounding area. This issue has to be considered in the early stages of trajectory design and is related to the process of site selection.

Innovative trajectory generators are sought. Indeed current existing ones have detrimental shortcomings with regard to application in emergency landing application:

- search criterion is usually path length or fuel consumption for normal flight ; whereas flight time is more appropriate for emergency (for instance in case of fire on board, landing should occur



within 15 minutes at most)

- usual path planning techniques do not integrate the vehicle dynamics,
- current trajectory solvers have high computational complexity and their good behaviour depend heavily on the initial conditions, whereas in emergency landing these initial conditions can vary a lot
- safe emergency plan has to be determined real time : very fast computation of feasible trajectories is a must under stressful emergency landing situations.

Within Clean Sky 2, Large Aircraft DISruptive COckpit activities are performed within IADP Large Passenger Aircraft (LPA) whose aim is to enhance maturity of disruptive cockpit operations, functions and technologies for future large aircrafts. Major design hypothesis is a single pilot for the whole flight, with new assistance role, keeping an equivalent level of safety.

The SW function subject of this call is to be integrated into a new ground cockpit demonstrator demonstrator DISCO (LPA WP3.5, demonstration phase 2).

2. Scope of work

Expected work is aimed at increasing the usefulness of trajectory generators with the ultimate goal of improving safety in emergency landing situations.

The objective is to derive an integrated prototype of landing site selection and automatic trajectory generation with due consideration of: partially characterized remaining controllability of the aircraft, reachability conditions of landing sites such as endurance and range, complexity of trajectory to be performed and guaranteed issuing of a feasible path within a short real time constraint.

Objective in terms of technical maturity is TRL5.

Expected work encompasses the following items:

- Identification of the most appropriate technique for landing site selection with due regard to risks
- Selection of the most suitable path planning and trajectory generation solution in the operations research/artificial intelligence and dynamic optimization fields, including probabilistic approaches
- Development of a native code prototype sustaining the capability to identify reachable and safe landing sites, given a flight impairment level, and to rank them according to a quantified risk. Ground safety risk with regard to populated areas has to be taken care of.
- Development of a native code prototype sustaining the emergency landing trajectory generation capability to produce a feasible path from the degraded case occurrence point to the selected landing site, given the flight impairment level and the risks considerations. The output solution shall be flyable with a Flight Management System.
- Validation of the emergency landing trajectory planning module within an ad hoc simulator to be developed as part of the activities. Assumption is that it receives inputs from a fault detection and identification external block, not to be developed in the scope of this topic; emulation of a large set of failure scenarios and conditions is however required.

Preliminary technical requirements are as follows:

- Landing site selection accomplished within 2 s.
- Trajectory generation accomplished within 5 s.



The integrated prototype of landing site selection and emergency trajectory generation is expected to:

- be delivered as a software suite in a basic release running on Microsoft Windows XP Operating System preferably, on a current generation PC, and sharing processing resources with other applications;
- be delivered with source code (preferably: C, Ada);
- be delivered with test tools enabling to assess computing resources usage and real-time response of the basic release of the executable.
- be portable to other operating systems and platforms by performing minor adaptation of the source code (platform characteristics and compilation options should be contained in specific source packages)

Solutions shall be compliant with the ATM Masterplan.

At project execution level, where applicable, interaction with SESAR will be implemented and sharing of results will be pursued.

The work breakdown and deliverables proposed here below to achieve this goal may be rearranged by the partners to facilitate their workflow.

Tasks		
Ref. No.	Title – Description	Due Date
WP1	Technical resources and problem definition	T1 + 4 months
WP2	Domain driven analysis of landing site selection and trajectory generation techniques	T1 + 7 months
WP3	Development of the landing site selection capability	T1 + 19 months
WP4	Development of the trajectory generation capability	T1 + 19 months
WP5	Integrated capability verification and validation	T1 + 27 months
WP6	Maintenance/adaptation and final delivery	T1 + 36 months

WP1: Technical resources and problem definition

The objectives of this work package are to:

- describe technical resources :
 - aircraft data
 - input data for degraded cases : characteristics of situation and flight capabilities impairment,
 - data base for possible landing sites ; terrain, cultural data and demographic data
- define technical problem :
 - definition of the use cases
 - degraded cases considered
 - flight scenarios
- define technical requirements for :
 - landing site selection,
 - path / trajectory generation

Note that close interaction with Topic manager is mandatory for this Work Package. An initial set of four use cases is to be established within WP1, encompassing at least the following two cases : aviary hazard (ingestion of birds in engines) and fire on board.



Some constraints to be considered for landing sites and trajectory definition will be provided as inputs.

WP2: Domain driven analysis of landing site selection and trajectory generation techniques

The objectives of this work package are to:

- describe candidate landing site techniques,
- describe candidate trajectory generation techniques
- perform a domain driven analysis of the above techniques in view of the problem definition of WP1, with ranking,
- identify preferred solutions (a single technique or a compound of several ones) both for the landing selection and the trajectory generation items

WP3: Development of the landing site selection capability

- The objectives of this work package are to:
- define and describe solutions for landing site selection (external interfaces, internal parameters, relations between external interfaces and internal parameters),
- give a first description of validation tests to check technical requirements defined in WP1
- define and describe a preliminary validation plan (scenarios, criteria)
- develop software module prototype by implementing the solution according to the design established,
- document the architectural description of the prototype and usage guidelines

WP4: Development of the trajectory generation capability

- The objectives of this work package are to:
- define and describe solutions for trajectory generation (external interfaces, internal parameters, relations between external interfaces and internal parameters),
- give a first description of validation tests according to technical requirements of WP1
- define and describe a preliminary validation plan (scenarios, criteria)
- develop software module prototype by implementing the solution according to the design established,
- document the architectural description of the prototype and usage guidelines

WP5: Integrated capability verification and validation

- The objectives of this work package are to:
- develop an ad hoc simulator for testing purpose
- perform integration of the two modules within this simulator
- define detailed validation test plan for the two items (landing site selection and trajectory generation part),
- develop procedures,
- apply validation test plan and analyse results.

WP6: Maintenance/adaptation and final delivery

The objective of this work package is to ensure the maintenance of the developed components (landing site selection and automatic trajectory generation) until the end of the project by providing fixes of the last unsolved anomalies and the delivery of the final version.

3. Major Deliverables/ Milestones and schedule (estimate)

*Types: R=Report, D=Data, HW=Hardware

Deliverables			
Ref. No.	Title – Description	Type*	Due Date
D1.1	Technical Resources and Problem Definition Document	R	T1 + 2 months
D1.2	Technical Requirement Document (V1)	R	T1 + 4 months
D2.1	Trade-off report on landing site selection and trajectory generation techniques	R	T1 + 7 months
D3.1	Landing site selection solution description	R	T1 + 12 months
D3.2	Landing site selection Package Delivery (V0.1)	D	T1 + 18 months
D3.3	Landing site selection Validation Test Plan (V0.1)	R	T1 + 18 months
D4.1	Trajectory generation solution description	R	T1 + 12 months
D4.2	Trajectory generation Package Delivery (V0.2)	D	T1 + 18 months
D4.3	Trajectory generation Validation Test Plan (V0.2)	R	T1 + 18 months
D5.1	Integrated Capability Test Plan(V1)	R	T1 + 21 months
D5.2	Integrated Capability Package Delivery (V1)	D	T1 + 26 months
D5.3	Integrated Capability Test Report (V1)	R	T1 + 26 months
D6.1	Integrated Capability Package Delivery (V2)	D	T1 + 35 months
D6.1	Update of V1 documents if needed (V2)	R	T1 + 35 months

Milestones (when appropriate)			
Ref. No.	Title – Description	Type	Due Date
M1	Landing site selection Prototype Development Readiness Review		T1 + 13 months
M2	Trajectory generation Prototype Development Readiness Review		T1 + 13 months
M3	V1 Results Review		T1 + 27 months
M4	Final Acceptance		T1 + 36 months

4. Special skills, Capabilities, Certification expected from the Applicant(s)

This work could benefit from:

- the experience of Advanced Research Institutes with a strong background on trajectory generation,
- the experience of an institution with background on actual past degraded cases leading to aircraft emergency landings.

5. Abbreviations

FMS Flight Management System
 IVV Integration, Validation and Verification

5. Clean Sky 2 – Fast Rotorcraft IADP

I. JTI-CS2-2018-CFP09-FRC-01-25: Smart Active Inceptors System definition for Tilt Rotor application

Type of action (RIA/IA/CSA):		RIA	
Programme Area:		FRC	
(CS2 JTP 2015) WP Ref.:		WP 1.2.3	
Indicative Funding Topic Value (in k€):		1250	
Topic Leader:	Leonardo Helicopters	Type of Agreement:	Implementation Agreement
Duration of the action (in Months):	18	Indicative Start Date (at the earliest)⁴⁶:	Q3 2019

Topic Identification Code	Title
JTI-CS2-2018-CFP09-FRC-01-25	Smart Active Inceptors System definition for Tilt Rotor application
Short description	
The present activity involves the conceptual definition of smart fly-by-wire active inceptors system for the future generation cockpit of a civil tiltrotor. The design will be focused at exploring and assessing mechanical designs which enhance piloting effectiveness for tilt rotor application, at improving functionalities capitalising on active features, and at optimising weight, volumes, complexity and integration within novel distributed fly-by-wire Flight Control System.	

Links to the Clean Sky 2 Programme High-level Objectives ⁴⁷				
This topic is located in the demonstration area:		NextGenCTR – TD / Cockpit& Avionics		
The outcome of the project will mainly contribute to the following conceptual aircraft/air transport type as presented in the scene setter:		NextGenCTR		
With expected impacts related to the Programme high-level objectives:				
Reducing CO ₂ emissions	Reducing NO _x emissions	Reducing Noise emissions	Improving EU Competitiveness	Improving Mobility
<input type="checkbox"/>	<input type="checkbox"/>	<input type="checkbox"/>	<input checked="" type="checkbox"/>	<input checked="" type="checkbox"/>

⁴⁶ The start date corresponds to actual start date with all legal documents in place.

⁴⁷ For further info see Chapter 1 “Introduction to the Programme Scene Setter / Objectives” with key technology themes / demonstration areas. Detailed information available in the CS2 Development Plan accessible via the Clean Sky JU Website and EC Participant Portal.



1. Background

The aim of the Fast Rotorcraft (FRC) project is to use technologies developed through the Clean Sky Programme to demonstrate a compound rotorcraft configuration that combines the vertical lift capability of the conventional helicopter with the speed capability of a fixed wing aircraft in a sustainable way. In the framework of Clean Sky 2 FRC IADP, the present Call requires Applicant/s (company or consortium) to provide innovative engineering solutions for the Tiltrotor NextGen CTR demonstrator cockpit inceptors. The present document describes also the general requirements that JU shall consider for the selection of the appropriate Applicant/s for this technology development.

The main objective of this new technology is to make piloting of Tilt Rotor more intuitive and effective; to achieve this, inceptors design has to be developed for this peculiar aircraft. Hence, the design has to focus on inceptors' mechanical interface and ergonomics so that FCS augmentation can be further improved. Moreover, increased situational awareness allowed by active inceptors can be made more specific by tailoring dedicated functionalities to Tilt Rotor application.

2. Scope of work

The main objective of this technology line is to design, develop, and manufacture the cockpit inceptors system needed to translate the NGCTR pilots' basic inputs (pilot and co-pilot) into suitable digital commands to the aircraft Fly-By-Wire Flight Control System, whilst providing adequate cues to the crew. The activity of the present call shall culminate with the specification of a Smart Active Inceptors System for NGCTR tiltrotor application.

The Inceptors System shall allow aircraft control by translating the pilots' and co-pilot's basic inputs into suitable digital commands to the aircraft FCS, by means of

- pilot's and co-pilot's right-hand active inceptors
- pilot's and co-pilot's left-hand active inceptors
- pilot's and co-pilot's pedals⁴⁸

Inceptors ergonomic and functionality shall be designed having pilot comfort and workload reduction as a target.

Each pair of equivalent inceptors (i.e., pilots' and co-pilot's right-hand inceptors, pilots' and co-pilot's left-hand inceptors, pilots' and co-pilot's pedals), shall be controlled to simulate a mechanical linkage between the two grips and to ensure that pilot and copilot inputs are coordinated and consistent.

Finally, in order to support NextGen CTR Flight Control System development and integration tasks, the Applicant/s will develop, share with WAL and maintain for the whole project life a modeling and simulation tool of the flight control inceptors. The use of modeling and simulation tool, in its final version at the end of the project, will be granted to WAL also after the project termination.

The detailed requirements for the system interfaces with the aircraft shall be part of dedicated discussion with selected Partner(s), following the signature of dedicated NDA or equivalent commitment.

• Mechanical and ergonomic definition

Tiltrotor control presents specific peculiarities which make traditional inceptors not fully applicable in all tiltrotor flights phase. Hence, a research activity to define the most effective inceptors configuration for tiltrotor application must be implemented.

Starting from tiltrotor operative requirements provided by WAL, Applicant(s) shall

⁴⁸ Pedals are intended as inceptors, as per SAE ARP 5764.

1. Identify possible inceptors mechanical/ergonomic solutions which would be compliant with operative requirements.

Different ergonomics architecture shall be considered, for instance

- Side-stick short pole inceptor.
- Rotary inceptor
- Linear inceptor
- A combination of the above
- Any configuration conceived by the Applicant.

The number of degrees of freedom is part of the evaluation.

Furthermore, an analysis to evaluate the potential removal of pedals thanks to proper left- or right-hand inceptor design should be evaluated.

2. Provide a preliminary evaluation of all solutions identified in previous step, for instance leveraging on simulation, similar or equivalent units already implemented, 3D-printed prototypes⁴⁹.
3. From solutions conceived and evaluated in previous steps, a maximum of three solutions shall be selected by WAL for test bench validation. Prototypes⁵⁰ suitable for test bench validation shall be produced⁵¹

The validation will consist in pilot-in-the-loop simulation at WAL premises, with inceptors prototypes (including grips) provided by the Applicant/s. The aircraft dynamic model and the set of applicable control laws will be under WAL responsibility.

4. Results from test bench validation shall be used by WAL to select final configuration

- Active functionalities

Every inceptor shall be capable to provide feedbacks to the pilot by means of real-time force and/or haptic feedbacks (for instance, as described in SAE ARP 5764, variable spring gradients, force breakouts, detents, ramps, gates, soft/hard stops, etc)

Detailed definition of these feedbacks will be defined during development, and will be aimed at improving pilots-FCS interaction for a tiltrotor application.

All functionalities will be programmable run-time by FCS. For instance, FCS can require run-time specific force gradient, friction values, apparent mass, can require a detent, a soft-stop, a hard-stop, a stick-shaker, can request inceptor back-drive. The complete definition of these functionalities, their priority and how they will be commanded by FCS will be defined during project negotiations.

Every inceptor shall be capable to provide feedbacks to the pilot by means of real-time force and/or haptic feedbacks (for instance, as described in SAE ARP 5764, variable spring gradients, force breakouts, detents, ramps, gates, soft/hard stops, etc)

Detailed definition of these feedbacks will be defined as a result of WAL operative requirements analysis, and will be aimed at improving pilots-FCS interaction for a tiltrotor application.

All functionalities will be programmable run-time by FCS. For instance, FCS can require run-time specific force gradient, friction values, and apparent mass, can require a detent, a soft-stop, a hard-stop, a stick-shaker, can request inceptor back-drive. The complete definition of these functionalities, their priority and how they will be commanded by FCS will be defined during project negotiations.

Active functionalities shall be implemented and tested in prototypes foreseen for test bench validation,

⁴⁹ Prototypes cover all units (i.e. right-hand, left-hand and pedals) for single-pilot simulation harness

⁵⁰ Prototypes cover all units (i.e. right-hand, left-hand and pedals) for single-pilot simulation harness

⁵¹ Prototypes shall include all required SW necessary to appropriately drive the HW

as detailed in point 3 of section above.

- Physical characteristics

Care must be taken in order to minimize system weight and dimensions, while taking into account its operational lifecycle, its operative condition and required functionalities and performances.

It will be required to optimise design with respect to installation, in order to facilitate pilots ingress and egress into the cockpit while minimising interface with other cockpit systems.

- Tasks description

Tasks		
Ref. No.	Title - Description	Due Date
T1	Operational Requirements analysis	t0+1 months
T2	Identification of different potential solutions.	t0+3 months
T3	Potential solutions evaluation.	t0+5 months
T4	Test Bench Prototypes production – drop #1.	t0+6 months
T5	Test Bench Prototypes production – drop #2.	t0+9 months
T6	Test Bench Prototypes production – drop #3.	t0+12 months
T7	Potential solutions test-bench Validation.	t0+17 months
T8	Specification definition.	t0+18 months

3. Major Deliverables/ Milestones and schedule (estimate)

*Type: R=Report, D=Data, HW=Hardware

Deliverables			
Ref. No.	Title - Description	Type	Due Date
D.1	Concept Exploration & Definition	R	t0 + 3 months
D.2	Evaluation Prototypes	HW	t0 + 5 months
D.3	Test Bench Prototypes #1	HW	t0 + 6 months
D.4	Test Bench Prototypes #2	HW	t0 + 9 months
D.5	Test Bench Prototypes #3	HW	t0 + 12 months
D.6	Inceptors Specification	R	t0 + 17 months

Milestones			
Ref. No.	Title – Description	Type	Due Date
M1	System Requirement Review	RM	t0 + 3 months
M2	Preliminary Solutions Review	RM	t0 + 5 months
M3	Test Bench Evaluation Review	RM	t0 + 17 months
M4	Specification Review	RM	t0 + 18 months

4. Special skills, Capabilities, Certification expected from the Applicant(s)

As a general remark, it is highly recommended that the proposed technologies have at least TRL 4 at T0. Moreover, the Applicant(s) shall own the following pedigree and special skills:

- Compliance to SAE AS9100.
- Experience of aeronautic rules, certification processes and quality requirements.
- Experience in design and validation of airborne equipment, either cockpit flight control systems, avionics systems (embedding complex HW and DAL-A SW) or both, according to RTCA-DO-160, RTCA-DO-178 and RTCA-DO-254 (or other civil or military equivalent standards) for safety critical equipment.
- Familiarity with EMI compatibility issues: capacity to design complex electronic HW in compliance with EMC guidelines, and experience in performing EMC justification analyses and experimental assessments according to RTCA-DO-160, EUROCAE ED-107/ARP-5583, ED-81/ARP-5413 and ED-84/ARP-5412 or equivalent civil or military standards (TBC).
- Experience in research, development and manufacturing (or integration) in the following technology fields:
 - Cockpit flight controls, with particular emphasis on active stick design as per SAE-ARP-5764 guidelines.
 - High performance DC brushless servomotors and drive systems,
 - Compact and reliable sensors and switches.
 - High integrity control electronics.
 - Grip ergonomic design and optimisation.
- Design Organization Approval (DOA) desirable.
- Shape, component design and structural analysis using CATIA v5 and NASTRAN, or compatible SW tools.
- Capacity to optimize the HW and SW design, to model mathematically/numerically complex mechatronic systems with suitable simulation tools (Matlab/Simulink, Dymola/Modelica, etc.) and to analyze both simulation and experimental results to ensure that the various required performance goals are met.
- Capacity to repair “in-shop” equipment due to manufacturing deviations.

Detailed Quality Assurance Requirements for Supplier will be provided to the selected Partner(s) following the signature of dedicated NDA or equivalent commitment.

5. Abbreviations

AIS	Active Inceptor System
BIT	Built In Test
CAN	Controller Area Network
CDR	Critical Design Review
CS2	Clean Sky 2
DAL	Design Assurance Level
DDP	Declaration of Design and Performance
DMU	Digital Mock Up
DOA	Design Organization Approval
EFA	Experimental Flight Approval
EMC	Electro-Magnetic Compatibility
EMI	Electro-Magnetic Interference
FBW	Fly By Wire
FCS	Flight Control System
FRC	Fast RotorCraft



IADP	Innovative Aircraft Demonstrator Platform
ITD	Integrated Technology Demonstrator
JU	Joint Undertaking
FPP	Key Performance Parameters
NDA	Non Disclosure Agreement
NGCTR	Next Generation Civil TiltRotor
PDR	Preliminary Design Review
PR	Problem Report
SCU	Stick Control Unit
SOF	Safety of Flight
SRR	System Requirement Review
TBC	To Be Confirmed
TBD	To Be Defined
TTP	Time Triggered Protocol
TRL	Technology Readiness Level
TRR	Test Readiness Review
WAL	Work Area Leader

II. JTI-CS2-2018-CFP09-FRC-01-26: Design, manufacture and deliver a high performance, low cost, low weight Nacelle Structure for Next Generation TiltRotor (NGCTR) - Technology Demonstrator (TD)

Type of action (RIA/IA/CSA):		IA	
Programme Area:		FRC	
(CS2 JTP 2015) WP Ref.:		WP 1.2	
Indicative Funding Topic Value (in k€):		5200	
Topic Leader:	Leonardo Helicopters	Type of Agreement:	Implementation Agreement
Duration of the action (in Months):	40	Indicative Start Date (at the earliest)⁵²:	Q3 2019

Topic Identification Code	Title
JTI-CS2-2018-CFP09-FRC-01-26	Design, manufacture and deliver a high performance, low cost, low weight Nacelle Structure for Next Generation TiltRotor (NGCTR) - Technology Demonstrator (TD)

Short description
<p>The aim of this Topic is to design, manufacture, test and deliver an innovative tiltrotor nacelle structure for experimental flight aircraft (NGCTR-TD) starting from a basic architectural definition supplied by the IADP Leader. The Activity shall be done by mean of innovative, lightweight materials and industrialization technologies to allow the new architecture to be implemented with the opportunity, for some new technologies, to be investigated in terms of fire resistant materials, fixed-tilting fairing interface management and control of structural borne vibration.</p> <p>Moreover, the required activity will include the support of the IADP Leader to the nacelle integration into an innovative Tiltrotor Technology Demonstrator wing structure for the duration of the Clean Sky 2 programme.</p>

Links to the Clean Sky 2 Programme High-level Objectives ⁵³				
This topic is located in the demonstration area:		NextGenCTR – TD / Advanced Airframe Architectures		
The outcome of the project will mainly contribute to the following conceptual aircraft/air transport type as presented in the scene setter:		NextGenCTR		
With expected impacts related to the Programme high-level objectives:				
Reducing CO ₂ emissions	Reducing NO _x emissions	Reducing Noise emissions	Improving EU Competitiveness	Improving Mobility
<input checked="" type="checkbox"/>	<input checked="" type="checkbox"/>	<input checked="" type="checkbox"/>	<input checked="" type="checkbox"/>	<input checked="" type="checkbox"/>

⁵² The start date corresponds to actual start date with all legal documents in place.

⁵³ For further info see Chapter 1 “Introduction to the Programme Scene Setter / Objectives” with key technology themes / demonstration areas. Detailed information available in the CS2 Development Plan accessible via the Clean Sky JU Website and EC Participant Portal.

1. Background

Leonardo Helicopter Division (LHD) is currently working with in the European Union Clean Sky 2 framework to produce a flying demonstrator which will allow the development of the key technologies to produce the Next Generation Civil Tilt Rotor (NGCTR) aircraft following on from existing ones architecture. This technology demonstrator (TD) will develop a new wing, new nacelles and a new tail. The technology demonstrator will have a fixed, non-tilting engine and nacelle with rotor tilt achieved via a new gearbox concept. This gives also the opportunity for some new technologies to be investigated in terms of fire resistant materials, fixed-tilting fairing interface management and control of structural borne vibration.

2. Scope of work

- NGCTR TD Nacelle Description

There are two nacelles located port and starboard at the outboard tips of the wing. Each nacelle houses an engine with exhaust, fire detection and suppression system, proprotor gearbox, interconnecting driveshaft (ICDS), air intake and associated airframe systems such as fuel, engine drains, bleed air and hydraulics. In addition there are electrical and avionic installations necessary for the control of the engine and proprotor system and the conversion actuator which allows transition from aeroplane to helicopter mode and back again. These are all housed within various fairings with provision for maintainer access. Unusually, the NGCTR nacelles do not provide the support for the engines or gearboxes, which are instead mounted directly to the main wing box. Some parts of the nacelle are subject to a range of elevated temperatures dependant on their location within the nacelle.

Figure 1 (below) shows the new concept proposed for new NGCTR TD. The new design will be developed to accommodate:

- the tilting requirement from Airplane to VTOL (helicopter) mode
- nacelle components not currently within the preliminary nacelle surfaces
- attachment to wing structure
- interface with engine intake and exhaust

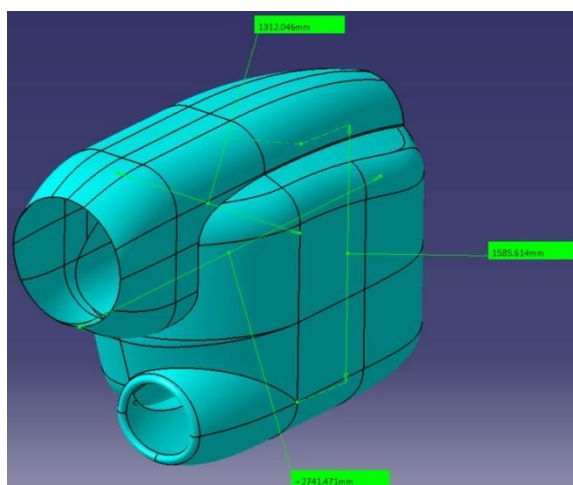

Figure 1 – Nacelle Fairing Components (in Airplane Mode)



- Technology Development

The NGCTR TD is only the first step on the journey to producing the NGCTR. Therefore it is intended to also research and develop technologies which may be beneficial to the NGCTR but not necessarily fly on the TD.

- Basic Construction

The novel wing construction and engine and gearbox mounting system provide little space for the attachment of a conventional nacelle structure such as that found on the AW609. Typically, several supporting elements are needed to accommodate the installation of secondary structure and nacelle equipment to the primary structure, such as overlaps of angular brackets to be riveted, joggled, welded, etc. resulting in a significant part number count and related assemblies which can also be subject to misalignments that need to be corrected in the assembly phase.

It is therefore proposed to review the nacelle concept to minimise the total number of parts while maximising access to the systems contained within. It is foreseen that this will be accomplished by innovative use of integrally stiffened monocoque composite shells to replace the traditional concept of using a metallic skeleton structure with skins fitted to it. Studies should be performed on the internal shape of the structure with an aim to optimising the air flow to achieve maximum bay cooling.

- Novel Material Firewalls

The firewalls provide a barrier which prevents the spread of fire and protects critical structures and systems until the fire can be extinguished by the on board systems, whilst maintaining their structural integrity during fire exposure (15min, fireproof characteristics as per ISO2685). Conventionally firewalls are made from titanium sheet, contain many parts such as, but not limited to, seals, recesses, supporting brackets, bulkheads, etc., which can be difficult to manufacture and are time consuming to assemble. It is proposed, leveraging existing research where possible, to determine if a suitable alternative material exists which could be used. The aim of this would be to produce a lighter firewall structure with fewer parts and simpler assembly. A trade study on cost should be performed. It is proposed to develop this technology up to and including a ground fire test and vibration test.

- Novel Techniques for the Reduction of Structure Borne Vibration and Noise

The Proprotor used on this aircraft shares many of the vibration characteristics of a conventional helicopter rotor. This results in significant high frequency loading being applied to the nacelle, wing interface and outboard wing. This vibratory loading, if of sufficient magnitude, can have a disproportionate effect on the fatigue life of nearby components. Therefore it is proposed to investigate technologies such as high damping materials and passive damping systems to see if high frequency fatigue loads in the wing can be reduced to non-damaging levels. It is proposed to develop this technology up to the level where it can be assessed by ground testing. Moreover, the novel material shall be tailored to mitigate and reduce the nacelle interior noise propagation outside the nacelle itself contributing to maintain low noise level even on ground operation. The possible use of new simulation tools to predict the external noise could also be investigated.

- Technology and Architecture Scalability

A further objective of the NGCTR programme is to exploit the technology and develop a larger aircraft and hence the design of the NGCTR TD nacelle shall be scalable and certifiable in the future.

- Partner Workshare & Statement of Work

Figure 2 shows in graphical form the Partner Work Breakdown Structure. Figure 3 shows the key development stages for the NGCTR TD.

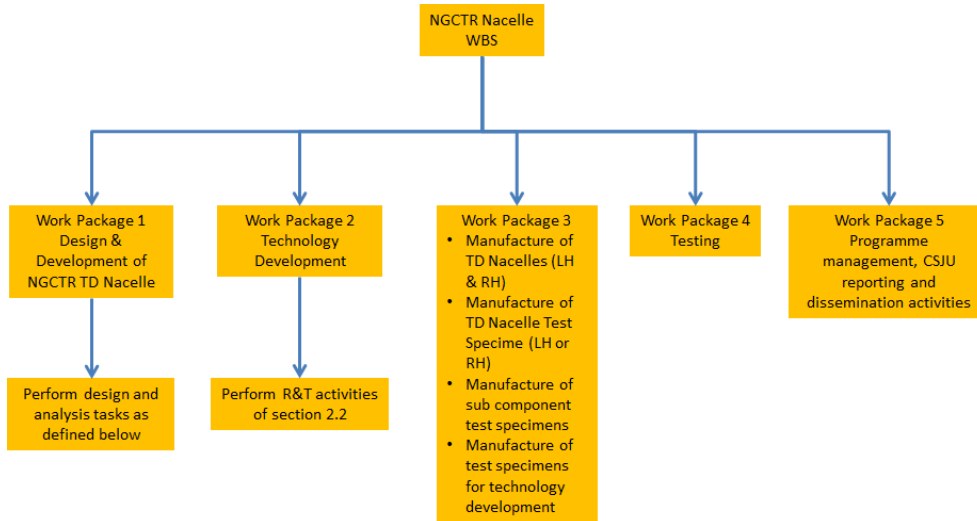

Figure 2 – Partner Work Breakdown Structure

Task	2018		2019		2020		2021		2022		2023	
	H2	H1	H2	H1	H2	H1	H2	H1	H2	H1	H2	
Aircraft PDR		★										
Aircraft CDR					★							
Aircraft Hardware Available							★					
Aircraft TRR										★		
Aircraft FRR											★	
First Flight of TD												★

Figure 3 - Key NGCTR Development Gates

– Design, Development and Manufacturing

The Partner shall work with the IADP Leader to develop the NGCTR TD Nacelle Structure as defined in Figure 1 to a level where they can be manufactured and installed on the NGCTR TD for flight test.

IADP Leader will develop the preliminary design in order to successfully support Aircraft Level PDR.

After this phase is completed (after PDR), the selected Partner shall be responsible for:

- Detail design and manufacture of the nacelle tilting structural elements. This includes the production of all drawings and stress analysis necessary to manufacture the nacelle tilting structure for the NGCTR TD, manufacture of the Nacelle tilting structure and provision of post design, manufacturing support and tooling. The design of the tilting structure shall recognise any requirements for the fitting and installation of the other nacelle structural elements and systems. All functional requirements, as defined by LH, shall be taken into account in the design phase, such as, but not limited to, temperature cycles, birdstrike resistance capabilities, vibrational environment, draining & ventilation capabilities, accessibility & maintainability etc.
- Detail design and manufacture of the nacelle fixed structural elements interfacing with the tilting ones including the interface mechanism. This includes the production of all drawings and stress analysis necessary to manufacture the cowling / fairing support fixed structure for the NGCTR TD,

manufacture of the fixed structure, integration of the tilting and fixed structure and provision of post design, manufacturing support and tooling. All functional requirements, as defined by LHD, shall be taken into account in the design phase, such as, but not limited to, temperature cycles, bird strike resistance, water-tightness capabilities, draining & ventilation capabilities, accessibility & maintainability, etc.

- c) Detail design and manufacture of the nacelle fixed structural elements interfacing with the engine bay incorporating thermal protection for the wing box. This will include the production of all drawings and stress analysis necessary to manufacture the interface structure for the NGCTR TD, manufacture of the interface structure, integration of the interface structure with the surrounding nacelle elements and provision of post design, manufacturing support and tooling. All functional requirements, as defined by LHD, shall be taken into account in the design phase, such as, but not limited to, temperature cycles, bird strike resistance, water-tightness capabilities, draining & ventilation capabilities, accessibility & maintainability, etc.
- d) Detail design and manufacture of the nacelle engine bay structural elements. This will include the production of all drawings and stress analysis necessary to manufacture the cowling, firewalls, seals, ducts, engine mounts, thermal blankets and engine bay floor for the NGCTR TD, manufacture of such elements and provision of post design, manufacturing support and tooling. All functional requirements, as defined by LH, shall be taken into account in the design phase, such as, but not limited to, fireproof, temperature cycles, bird strike resistance, water-tightness capabilities, draining & ventilation capabilities, accessibility & maintainability, etc.
- e) Develop and execute plans for design, analysis, manufacture and test as necessary for the elements defined at points a) to d) in accordance with NGCTR TD Master Plan milestones and deadlines as defined by LHD.
- f) Perform the following tests for NGCTR TD nacelle flight clearance justification: fire test; birdstrike; structural element (as required); endurance of tilting fairing mechanism; material coupon (as required); any other tests required.
- g) Provide all deliverables and support to LHD for the production of the relevant documentation to achieve a permit to fly for the TD.
- h) To research and develop as necessary the proposed technologies defined in sections 2.2 & 2.3 to a level where as a goal they can be flown on the TD but as a minimum, they can be tested on the ground. The subsequent integration of these technologies into the TD, upon achievement of an adequate TRL, shall be subject to a dedicated assessment and definition of an appropriate integration plan with LHD. Otherwise standard technologies shall be used for actual development, design, manufacturing and installation on the TD. Specific decision points shall be identified in the relevant plans for each proposed technology in line with the LHD program Master Plan. The progressive introduction of technology through the TD flight test phase can be considered. This will be discussed with the partner during the negotiation phase.
- i) All the nacelle components shall meet the interface requirements as defined by LHD, and shall be subject to periodic reviews with LHD/partner engineering teams to ensure that the currency of the nacelle and other aircraft designs are maintained.
- j) Adequate support for all manufactured parts shall be guaranteed for the duration of the flight test programme. In addition, adequate maintenance and repair procedures shall be defined to manage the typical issues found on a development program (minor damages or cracks, configuration modifications, etc.).

– Instrumentation

The instrumentation requirements shall be jointly agreed to ensure the compatibility with the data acquisition systems (Ground and Flight).

– Risk Mitigation

As a risk mitigation measure, conventional manufacturing processes and materials may be considered where it can be demonstrated that there is a time or cost benefit without any adverse effect on the scope and validity of the flight test programme.

3. Major Deliverables/ Milestones and schedule (estimate)

*Type: R=Report, RM=Review Meeting, D=Data, HW=Hardware

Deliverables			
Ref. No.	Title – Description	Type	Due Date
1	Kick-off meeting minutes (KOM)	R	T0
2	Progress Design Reviews (every 6 months after KOM)	R	T0+6
3	Minutes of NGCTR TD Nacelle Critical Design Review (CDR)	R	T0+12
4	NGCTR TD Nacelle Design Data Set and final Interface Definition Documents	R	T0+15
5	First Article Inspection Report	R	T0+24
6	Test Readiness Report	R	T0+24
7	Delivery of LH and RH Nacelles for flying aircraft	H	T0+28
8	Nacelle Stress and Test Report	R	T0+28
9	Minutes of NGCTR TD Test Readiness Review (TRR)	R	T0+40

Milestones (when appropriate)			
Ref. No.	Title – Description	Type	Due Date
1	Kick-off Meeting	RM	T0
2	Critical Design Review	RM	T0+12
3	First Article Inspection	RM	T0+24
4	Availability of Test Specimens	H	T0+24
5	Test Readiness Review	RM	T0+40

4. Special skills, Capabilities, Certification expected from the Applicant(s)

Suitable Partner(s) across the proposed team shall:

- Have as a minimum a proven track record of the construction of significant aircraft structural modules or components
- Be experienced in the design and manufacturing of structures in non-conventional and conventional composite materials (thermoset and thermoplastic plus high temperature systems) and innovative and conventional metallic components
- Have the capability to manufacture and assemble composite and metallic parts
- Use the design, analysis and configuration management tools of the aeronautical industry (e.g.: CATIA, VPM, DMU, Hypermesh, MSC Nastran, Abaqus, NASGRO, Fluent)
- Have a proven track record in the management of complex projects of research and manufacturing technologies
- Experience with TRL Reviews or equivalent technology readiness assessment techniques in research



and manufacturing projects in the aeronautical industry

- Proven experience of collaboration with other aeronautical companies in industrial air vehicle developments
- Have the capacity to support the production of documentation and means of compliance to achieve experimental prototype “Permit to Fly” with the appropriate Airworthiness Authorities
- Be capable of specifying and conducting material, structural and endurance tests including full scale
- Be capable of designing and incorporating repairs resulting from manufacturing deviations
- Be capable of evaluating design solutions and results IAW Eco-design rules and requirements
- Have qualification competences: design organization approval (DOA) is desirable but not mandatory
- Be capable to produce NGCTR components according to environmental Quality System international standards
- Be capable to manufacture, test, checks NGCTR components to assure the required production quality
- Have access to the qualification process to obtain the “Permit to Fly” of the NGCTR
- Be capable of designing and manufacturing/procuring all tooling and assembly jigs as required

Suitable Partner(s) should:

- Have experience of collaborating with industrial partners, institutions, technology centres, universities and OEMs (Original Equipment Manufacturers) within international R&T projects
- Have a Quality System approved to international standards (i.e. EN 9100:2009/ ISO 9001:2008/ ISO 14001:2004)
- Be capable of supporting the overall aircraft configuration management
- Be capable of performing Life Cycle Analysis (LCA) and Life Cycle Cost Analysis (LCCA) of materials and structures

5. Abbreviations

AFCS	Automatic Flight Control System
ATP	Acceptance Test Procedure
CDR	Critical Design Review
CPW	Core Partner Wave
CSJU	Clean Sky Joint Undertaking
DMU	Digital Mock Up
DOA	Design Organization Authority
EMC	Electro-Magnetic Compatibility
EN	European Normalization
HIRF	High Intensity Radiated Fields
IADP	Systems and Platforms Demonstrator
IAW	In Accordance With
ISO	International Organization for Standardization
ITD	Integrated Technology Demonstrator
LCA	Life Cycle Analysis
LCCA	Life Cycle Cost Analysis
LHD	Leonardo Helicopter Division
NGCTR TD	Next Generation Civil Tiltrotor Technology Demonstrator
NRC	Not Recurring Cost
OEM	Original Equipment Manufacturer



PDR	Preliminary Design Review
QTP	Qualification Test Proposal
QTR	Qualification Test Report
REACH	Register, Evaluation & Authorization of Chemical products
R&T	Research and Technology
SAR	Search and Rescue
STOL	Short Take-Off and Landing
Ta	Systems and Platforms Demonstrator
TD	Technology Demonstrator
TRL	Technology Readiness Level
TRR	Test Readiness Review
WBS	Work Break Down Structure
WP	Work Package

III. JTI-CS2-2018-CFP09-FRC-01-27: Tilt Rotor Whirl Flutter experimental investigation and assessment

Type of action (RIA/IA/CSA):		RIA	
Programme Area:		FRC	
(CS2 JTP 2015) WP Ref.:		WP 1.4	
Indicative Funding Topic Value (in k€):		5000	
Topic Leader:	Leonardo Helicopters	Type of Agreement:	Implementation Agreement
Duration of the action (in Months):	54	Indicative Start Date (at the earliest)⁵⁴:	Q3 2019

Topic Identification Code	Title
JTI-CS2-2018-CFP09-FRC-01-27	Tilt Rotor Whirl Flutter experimental investigation and assessment
Short description	
<p>The main content of this Topic is to design, manufacture, test and post-process the test data of a semi-span aero-elastic tiltrotor powered model in a suitable wind tunnel test facility in order to support IADP Leader in the study of the feasibility, compatibility and effectiveness of key enabling technologies of the Next Generation Civil Tilt Rotor. The Wind tunnel test campaign shall be conducted to achieve initial and final gates, described later. The main features of the model are to host an innovative split-gearbox concept, an advanced wing design which incorporates an optimized airfoil thickness ratio and structural weight, suitable to implement a movable surface concept aimed to reduce the download caused by the rotor/wing interaction in hover. With current cutting edge technologies, the rotor/wing whirl-mode stability requirements represent a challenge in the design, impacting to cruise efficiency and to maximum speed in airplane mode. The research and validation in this field, peculiar to tiltrotors only, are the fundamental steps to develop more efficient tiltrotor configurations meeting operational, economic and environmental requirements. Advances in fundamental physics knowledge and associated growth in the scientific community are then expected with this Topic.</p>	

Links to the Clean Sky 2 Programme High-level Objectives ⁵⁵				
This topic is located in the demonstration area:		NextGenCTR – TD / Advanced Airframe Architectures		
The outcome of the project will mainly contribute to the following conceptual aircraft/air transport type as presented in the scene setter:		NextGenCTR		
With expected impacts related to the Programme high-level objectives:				
Reducing CO ₂ emissions	Reducing NO _x emissions	Reducing Noise emissions	Improving EU Competitiveness	Improving Mobility
<input checked="" type="checkbox"/>	<input checked="" type="checkbox"/>	<input checked="" type="checkbox"/>	<input checked="" type="checkbox"/>	<input checked="" type="checkbox"/>

⁵⁴ The start date corresponds to actual start date with all legal documents in place.

⁵⁵ For further info see Chapter 1 “Introduction to the Programme Scene Setter / Objectives” with key technology themes / demonstration areas. Detailed information available in the CS2 Development Plan accessible via the Clean Sky JU Website and EC Participant Portal.



1. Background

Tiltrotor aircraft combine Vertical Takeoff and Landing (VTOL) capabilities with speed and range performances greater than those provided by current helicopters. With current technology, the rotor/wing whirl-mode stability requirements represent a major constraint on this design, resulting in significant limitations to cruise efficiency and maximum speed in airplane mode.

Research and validation of new technical solutions are steps of fundamental importance to develop more efficient tiltrotor designs meeting operational, economic and environmental requirements.

The Next Generation Civil Tiltrotor (NGCTR) is the aircraft that will embed all the key technologies as demonstrated by the flight test article NGCTR-TD (Technology Demonstrator) that will have its maiden flight (Q2 2023) before the Clean Sky 2 closure. NGCTR introduces in its design innovative solutions aimed at increasing the cruise efficiency, productivity and hover performances:

- Highly efficient wing with a 21% t/c airfoil pitching moment constraint
- Split gearbox solution for shaft tilting mechanism
- Large chord ratio movable surface concept

These can have a significant impact on the structural dynamics and hence to whirl flutter stability boundaries.

Time Frame

1. Short term: For the NGCTR TD first flight phase (across 2023) the whirl flutter stability analysis will be covered on the basis of the experience done on AW609.
This phase will not include the AirPlane mode (i.e. with rotor axis aligned with the tunnel airflow direction) and relevant flight envelope expansion, however the following phase will need a thorough validation of the methodologies, tools and design envelopes as far as whirl flutter is concerned.
2. Medium term (subsequent TD flight testing phases): The WT test results object of this call will be the only experimental source to be used to perform the above activity consistently with the NGCTR key driving technologies.
These experimental validation (when limited to Mach 0.36 for NGCTR-TD: Initial Gate) will enable to raise dramatically the confidence for the NGCTR-TD flight test expansion at high speed-altitude (2024-2025).
3. Long Term: The objective is to build a set of scalable data to assess trade-off between standard and innovative design spaces (e.g. active systems) and ultimately to design next generation family of tiltrotors, which will not have design speed limitations (up to Mach 0.56: Final Gate).

As part of this project, a semi-span aeroelastic tiltrotor model will be tested in a suitable wind tunnel test facility to study feasibility, compatibility and effectiveness of the above described technologies.

All these information will reduce the technical risk of the future tiltrotor programs.

2. Scope of work

Aim of the proposed Topic is to design, manufacture and test in wind tunnel an aeroelastically scaled, powered, tiltrotor semi-span model (as shown in Figure 1) to study the whirl flutter stability of a configuration implementing new technical solutions.

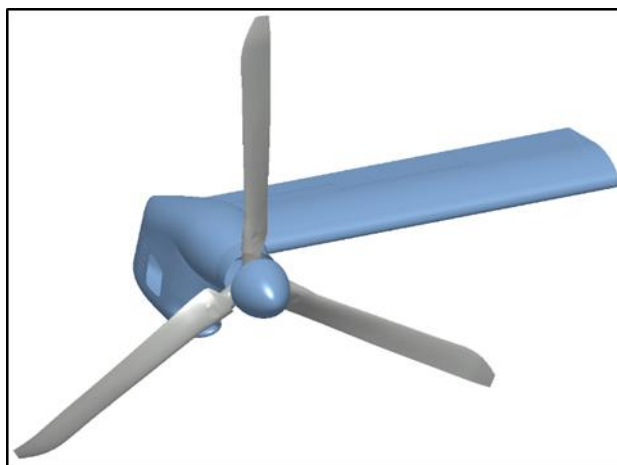

Figure 1 – Semi-span model main components (reference only, not to scale)

The test model shall include:

- An aeroelastically scaled rotor system: blades, hub and controls.
- An aeroelastically scaled wing-nacelle system.
- a dynamically scaled drive system representative of the first relevant modes potentially able to couple with the other whirl flutter modes.

Details are provided in the following sections.

The Applicant shall structure its Proposal into six main tasks as hereafter described:

- Task 0: Management and project coordination
- Task 1: Preliminary assessment and Model Design
- Task 2: Aero-elastic model detailed design
- Task 3: Manufacturing, assembly
- Task 4: Model Preparation and Wind tunnel testing
- Task 5: Wind tunnel data analysis and post-processing

Task 1: Preliminary assessment and Model Design

The test rig shall be a semi-span tilt rotor model where wing, pylon and rotor systems are aeroelastically-scaled.

IADP Leader is considering as appropriate at this stage either full Mach scaling or Froude scaling, the latter associated with the use of heavy gas media in wind tunnel to reproduce Mach similarity at high Mach numbers (>0.36 , Initial Gate) for aerodynamic forces. The Applicant is requested to investigate and to propose any approach that, in his knowledge and experience, can satisfy the requirement.

If multiple solutions are offered the final one will be discussed and agreed during the negotiation phase with the IADP Leader in order to clearly define the entry criteria for Task 2.

The Applicant is requested to conduct trade-off studies on the subjects listed below:

- power management & transmission lay out
- appropriate model internal volume for instrumentation & control
- affordable load and stress levels
- tuning of model characteristics (e.g. modularity)

- easy access to the model and maintenance in order to properly manage possible conflicting requirements.

Task 1 will cover preliminary design activities necessary:

- To cover all aspects pertaining to the construction of an aeroelastically scaled model suitable to fit the key requirements as listed in Chapter 1 (Background).
- To determine its strength and stability margins to ensure safe operation in the selected wind tunnel.

And it will include:

- The capture of the IADP Leader requirements and familiarisation with the innovative technologies to be validated in the test rig of this topic.
- Thorough analysis of similar activities performed in the past (scientific experience, applicants experience, etc.). Dedicated workshops involving the IADP leader and the Applicant and aimed at identifying the most appropriate design criteria and manufacturing methodologies.
- Preliminary design of the model dynamically scaled main subsystems:
 - powered rotor;
 - wing-nacelle system allowing replacement of specific structural elements in order to introduce stiffness and masses local changes
 - drive system;

This study will cover the preparation of the analytical models and the execution of the analysis needed to assess the stability margins and the loads level throughout the whole test matrix to be investigated.

It will also cover the integration of all necessary measurements systems and associated devices used to collect data relating to rotor and wing loads (e.g., strain gauges, bending moments, shear forces), rotor motion (e.g., rotor flapping), wing modal response (e.g., accelerations) (a preliminary list of parameters to be recorded is presented in the Task3). In addition to the reading of the basic rotor operative status parameters (kinematics and performance), real time/near real time monitoring of modal damping and loads levels is mandatory. To this aim a suitable excitation method as well as the associated excitation system to characterize the whirl flutter modes (mode frequency, damping and shape) shall be identified.

- The selection of a suitable power system to cover the whole test matrix up to the maximum speed.
- The feasibility study of suitable active controls for aeroelastic stability augmentation , which can be integrated into the model design. Although the application of active devices is not requested on this Topic, they represent an innovative technology that can significantly improve the tiltrotor stability margins. This feasibility study will enable investigating these innovative technologies on this test rig in future test campaign.
- The assessment of the impact that the adopted technologies have on model simplicity, safety of operation, materials availability, costs and time schedule.

Inputs from IADP Leader at T0:

- Model rotor (blades and yoke) geometric, aerodynamic and dynamic characteristics, including: rotor speed range, collective pitch command range, control chain geometry, blade and yoke structural properties span-wise distribution, control chain stiffness.
- Model wing geometric, aerodynamic and dynamic characteristics
- Model pylon/nacelle dynamic characteristics

The above data will be subjected to the scaling rules, the model size and the heavy gas data (in case of Froude scaling) as described in the selected proposal.

Outputs from the Applicant at T0+8M:

- Report describing the preliminary design of the aeroelastic wind tunnel model
- Preliminary analytical model representing the design
- System Functional Review (Model requirements have been properly allocated to systems/sub-systems and integrated)

Task 2: Aeroelastic Model Detailed Design

Task 2 includes the activities necessary for the design of the aeroelastic wind tunnel model.

Wind Tunnel Model

With reference to the outcomes of the previous Task 1, the applicant shall design and manufacture an aeroelastically scaled, powered, tiltrotor semi-span model including the following main subsystems:

- Model Support System:
 - The system shall be designed to guarantee:
 - A cantilever constraint of the wing root to the wind tunnel (wall or floor);
 - A connection of the drive system with the power plant;
 - A suitable space for cable routing.
 - A suitable balance will measure the three forces and three moments reacted at the wing root.
- Wing:
 - It is configured as a straight wing with no sweep and no dihedral angle.
 - Its construction shall allow replacement of specific structural elements to introduce changes in stiffness and local masses, with the aim of validating optimal structural design choices.
 - Enough room shall be kept free to accommodate the various systems required for the conduction of the test campaign (e.g. hydraulic actuation, rotor power transmission, loads and acceleration gauges).
- Wing Fairing: It will reproduce the external aerodynamic shape of the wing and will be constrained to the structural part of the wing itself.
- pylon/nacelle:
 - The pylon/nacelle system is located at the wing tip.
 - It will accommodate a gearbox to transmit power to the rotor and a suitable balance to measure rotor thrust, torque, shear forces and flexural moments at the hub centre.
- drive system
It shall be designed to transmit the necessary power to the rotor and it will be dynamically scaled to reproduce the first mode able to couple with low frequencies wing/pylon/rotor modes.
- Power Unit
- Prop-rotor
 - Stiff in-plane, gimbal mounted rotor located in the front position of the nacelle.
 - The rotor is a three blades configuration, where the blades are mechanically mounted on a pre-coned flex-beam.
 - The blades shall be dynamically scaled and the modal description (frequency and shape) of, at least, the first significant/relevant elastic modes shall be guaranteed.
 - The design shall allow the installation of balance masses at proper locations in order to

- reduce 1/rev rotor unbalance.
- Blades and hub will be properly instrumented as defined in Task 1.
- A swashplate system and associated actuators shall be designed in order to introduce rotor blade pitch collective and cyclic inputs.
- o Spinner (ogive fairing covering the rotor hub): A spinner cone will be designed to provide an aerodynamic cover to the rotor hub and controls, respecting the dynamic scaling requirements of the rotor system.
- o excitation systems (design or pre-selection from suppliers)
- o Slip-ring or other system to transfer the data recorded on the rotor system to the non-rotating frame.
- o The model has to be designed to include all the necessary features to be properly integrated with the selected wind tunnel.

The model must be designed and manufactured considering the geometric constraints arising from the preliminary design in Task 1, after the most appropriate design criteria has been selected.

The main dimension constraints for the scaled model are as follows:

- A minimum rotor radius of 1.25m for the rotor model, on the basis of Reynolds number considerations and to minimize the effect of the installed instrumentation.
- The half-wing span length (from aircraft centerline up to rotor center) shall be 1.45R, being R the model rotor radius. Bigger dimensions up to +5% must be approved by IADP if needed for installations.
- In both the vertical and horizontal directions, the model size shall not exceed 60% of the wind tunnel test section dimensions.

Other aspects to be considered

- Signal processing electronics
- Data acquisition system
- Software for piloting and control console
- Instrumentation, sensors, cabling and connectors

Aerodynamic characteristics at wind tunnel Reynolds number

In order to properly correct the acquired wind tunnel data and to support the preparation of the analytical models necessary to clear the test campaign itself the Applicant is requested to determine the rotor blade and wing aerofoils aerodynamics characteristics at the Reynolds number values that can be achieved during the wind tunnel test campaign. To this aim, the Applicant can use experimental test (wind tunnel) or, as an alternative, numerical methods if their validation is demonstrated at the wind tunnel flow conditions.

Inputs from IADP Leader Consortium at T0+8M:

- o Deliverables from Task 1

Outputs from the Applicant at T0+17M:

- o PDR (Preliminary Design Review – go ahead with model detailed design)
- o Preliminary Design Report

Outputs from the Applicant at T0+29M:

- o Wind tunnel model component detailed design (Substantiation report, 3D CAD model, 2D manufacturing drawings)
- o CDR (Critical Design Review – go ahead with model manufacturing)
- o Aerofoils aerodynamic assessment report at wind tunnel flow conditions.

- Report to describe the updated analytical model used to validate the design, and to present the analytical results to clear the wind tunnel tests.

Task 3: Manufacturing, assembly

Task 3 includes the necessary activities for the wind-tunnel aeroelastic model manufacturing and instrumentation.

Model Instrumentation

The applicant must be able to provide the instrumentation required for the following measurements:

- General wind tunnel parameters: pressure, temperature, humidity, wind speed.
- Rotor blade loads: beam bending, chord bending and torsion.
- Rotor hub loads: beam bending, chord bending and torsion.
- Rotor Centre Accelerations (three axes).
- Rotor flapping angle.
- Rotor Commands (collective, cyclics)
- Rotor thrust, torque, shear forces and flexural moments at the hub centre
- Nacelle accelerometers (three axes)
- Wing loads: beam bending, chord bending and torsion in three stations along the wing.
- Wing accelerations (three axes) in three stations along the wing.
- Any additional devices/transducers/accelerometers the Applicant proposes to be added in order to better support the assessment

Outputs from the Applicant at T0+41M:

- Hardware delivery
- Model acceptance (by IADP Leader)

Task 4: Model Preparation and Wind tunnel testing

Given model complexity, the applicant shall allocate a sufficient time to complete its assembly, instrumentation, functional test, dynamic characterization, tracking and balancing, sensors calibration. These phases must be performed in a controlled environment located within the tunnel facility. A reasonable estimation of time from model acceptance to test readiness review is five months.

The dynamic characterization of the model shall determine the natural frequencies and mode shapes of the rotor-pylon-wing structure. This activity shall be performed on the model mounted on its final support in order to properly evaluate the impact of the model constraint.

The tracking and balancing of the rotor shall be performed so that each blade tip travels in the same plane and the centre of mass of the rotor is at, or nearly to, the centre of rotation in order to minimize the 1/rev vibration.

The installation of the model inside the wind tunnel test section shall be such that the rotor axis is aligned with the tunnel airflow direction. The IADP Leader will specify the test matrix with the combinations of airspeed, rotor rotational speed and controls to be investigated.

For each configuration, about 25 free stream Mach numbers will be investigated spanning the airspeed range from low speed up to the maximum test Mach number.

At each Mach number, after steady conditions have been achieved, the three whirl flutter modes (beam, chord and torsion of the pylon-wing system) will be firstly excited by introducing a perturbation with proper frequency and amplitude (for example, by using the rotor controls or other movable devices in the fixed system). The perturbation will be then suddenly stopped, letting the transient response to freely decay in order to determine the modal damping levels.



The above is estimated required 5 wind-on days of tunnel occupancy.

Three different configurations will be investigated (for a total of 15 wind-on days in single daily shift of 8 hours each):

- Baseline
- Baseline with mass changes (e.g. to account for a different fuel distribution within the wing)
- Baseline with local changes of structural stiffness (e.g. pylon conversion actuator system)

The wind tunnel test plan will be issued by the Applicant. This in order to define the most appropriate sequence of test points to optimize the tunnel occupancy for both wind-on and wind-off periods (taking into account the time to be allocated for model installation, configuration change and final disassembly. The wind tunnel test plan shall be in any case approved by the IADP in order to ensure that specific constraints are accounted for whenever the investigation of the test points need to follow a precise succession.

A suitable model piloting system and a piloting team shall be defined for execution of the test matrix and the real time monitoring of the model aeroelastic behaviour.

The wind tunnel tests will be representative of airplane mode forward flight conditions. At full scale the NGCTR will have to be investigated up to a maximum Mach number of 0.56 at sea level (Final Gate).

The Applicant shall execute all the necessary activities (both experimental and analytical) to clear the wind tunnel entries, in agreement with the structural substantiation requirements as delivered by the wind tunnel plant.

Inputs from Topic Leader:

- Wind tunnel test matrix – T0

Outputs from the Applicant:

- Wind tunnel test plan – T0+41M
- Test readiness review (go-no go) - T0+46M
- Wind Tunnel Test completion – T0+47M
- Wind-tunnel tests measurements preliminary report – T0+50M

Task 5: Wind tunnel data analysis and post-processing

Several physical quantities shall be measured in real time during the execution of the test matrix (e.g., control positions, accelerations and loads). Measured data will consist of time histories with a sample rate sufficient to accurately describe the response of all significant modes. All of the time histories shall be stored on proper supports to be made available to the topic leader for subsequent data analysis. A subset of critical parameters shall be monitored in real time telemetry (time and frequency domain) as necessary for safe conduction of the test matrix

Task 5 includes:

- a) Post processing of the recorded data.
- b) Preparation and delivery of data reports devised in such a manner to provide a condensed, easily accessible picture of the wind tunnel test results. The reports shall be prepared following a format to be agreed with the Topic Leader and shall cover the following points:
 - correction criteria used for post-processing, covering tunnel wall and support interferences (if any), buoyancy corrections and other aspects to be considered in the Applicant's wind tunnel.
 - Rotor flapping and controls position

- Load measurements from all balances
 - modal response characteristics (e.g. frequencies, modal damping, mode shapes)
 - load and acceleration data measured on the rotor and wing/nacelle systems
- c) Analytical results validation:
- Comparison between whirl flutter experimental data and analytical prediction from Task 2.
 - Model tuning as required to achieve the necessary correlation level

Outputs from the Applicant at T0+54M:

- Wind Tunnel Data Reports
- Analytical model and results validation

Project Time scheduling

The following table will list the deadline for each task completion:

Tasks		
Ref. No.	Title - Description	Due Date
Task 0	Management and project coordination	T0+54 m
Task 1	Preliminary assessment and model design	T0+8 m
Task 2	Aeroelastic model detailed design	T0+29 m
Task 3	Manufacturing, assembly	T0+41 m
Task 4	Model Preparation and Wind tunnel testing	T0+50 m
Task 5	Wind tunnel data analysis and post-processing	T0+54 m

3. Major deliverables/ Milestones and schedule (estimate)

*Type: R: Report - RM: Review Meeting - D: Delivery of hardware/software

Deliverables			
Ref. No.	Title - Description	Type	Due Date
Task 1	Preliminary analytical model assessment	R	T0+8 m
Task 2	PDR	RM	T0+17 m
Task 2	Preliminary design report	R	T0+17 m
Task 2	CDR	RM	T0+29 m
Task 2	Engineering drawings	R	T0+29 m
Task 2	Structural substantiation report	R	T0+29 m
Task 2	Dynamic stability report	R	T0+29 m
Task 2	Airfoils assessment at wind tunnel conditions	R	T0+29 m
Task 3	Model Delivery and Acceptance	D	T0+41 m
Task 3	Wind tunnel test plan	R	T0+41 m
Task 4	Test Readiness Review	RM	T0+46 m
Task 4	Wind Tunnel Entry	RM	T0+47 m
Task 4	Preliminary wind tunnel Data	R	T0+50 m
Task 5	Final Documentation (Wind tunnel test report, analytical model and results validation)	R	T0+54 m

Milestones (when appropriate)			
Ref. No.	Title - Description	Type	Due Date
M1	Kick-off meeting	RM	T0
M2	System Functional Review	RM	T0+8 m
M3	Model PDR (go ahead with detailed design)	RM	T0+17 m
M4	Model CDR (go ahead with manufacturing)	RM	T0+29 m
M5	Test Readiness Review (Go-Nogo After readiness review)	D	T0+46 m
M6	Wind Tunnel Entry	RM	T0+47 m
M7	Final Meeting	RM	T0+54 m

4. Special skills, Capabilities, Certification expected from the Applicant(s)

The Applicant must have qualified and demonstrated knowledge in rotorcraft dynamics and aerodynamics together with proven expertise in powered model design and test. Program management is another fundamental required skill, being this topic a multidisciplinary project that needs firm control on schedule, cost, and risk.

Detailed requirements and specifications for the applicant capabilities are listed below:

- Wind tunnel powered model design, instrumentation and manufacturing
- Wind tunnel powered model control, piloting
- Wind tunnel tests management, test conduction and experimental data analysis
- Knowledge and experience in rotorcraft aeromechanics
- Proven capability to manage projects by gathering several and different specialistic skills (model design and manufacturing, wind tunnel tests) and demonstrated capability to guarantee the project scheduling and milestones, due to the strong link this project has to the IADP Leader design process.
- A Consortium of partners is encouraged to apply this proposal in order to exploit any specific excellence in each selected field.

6. Clean Sky 2 – Airframe ITD

I. JTI-CS2-2018-CFP09-AIR-01-40: Anticontamination Coatings and Cleaning Solutions for Laminar Wings

Type of action (RIA/IA/CSA):		RIA	
Programme Area:		AIR	
(CS2 JTP 2015) WP Ref.:		WP A-2.2	
Indicative Funding Topic Value (in k€):		2000	
Topic Leader:	Airbus	Type of Agreement:	Implementation Agreement
Duration of the action (in Months):	29	Indicative Start Date (at the earliest)⁵⁶:	Q3 2019

Topic Identification Code	Title
JTI-CS2-2018-CFP09-AIR-01-40	Anticontamination Coatings and Cleaning Solutions for Laminar Wings
Short description	
Laminar wings must be free of insect's contaminations that can trigger boundary layer transition. This project aims at understanding the properties of insects' hemolymph during take-off and landing, and to understand the influence of surface type and environmental conditions on the modifications of hemolymph properties. Based on the results from this research, it will be possible to launch the development of new anti-contamination, low adhesion and post-contamination Cleaning Solutions to be flight tested. The developed solutions must be environmentally friendly.	

Links to the Clean Sky 2 Programme High-level Objectives ⁵⁷				
This topic is located in the demonstration area:		Advanced Laminar Flow Technologies		
The outcome of the project will mainly contribute to the following conceptual aircraft/air transport type as presented in the scene setter:		Advanced Long Range		
With expected impacts related to the Programme high-level objectives:				
Reducing CO₂ emissions	Reducing NO_x emissions	Reducing Noise emissions	Improving EU Competitiveness	Improving Mobility
<input checked="" type="checkbox"/>	<input type="checkbox"/>	<input type="checkbox"/>	<input type="checkbox"/>	<input type="checkbox"/>

⁵⁶ The start date corresponds to actual start date with all legal documents in place.

⁵⁷ For further info see Chapter 1 "Introduction to the Programme Scene Setter / Objectives" with key technology themes / demonstration areas. Detailed information available in the CS2 Development Plan accessible via the Clean Sky JU Website and EC Participant Portal.

1. Background

The current research & development proposed in this Call will be done in the frame of Clean Sky 2 and following the already successful and ongoing BLADE flight test campaign for NLF wings. It aims at mastering one of the essential technologies that will be key for industrial laminarity.

This call is related to activities running under the ITD Airframe WP A-2 oriented towards advanced laminarity but more specifically towards “NLF smart integrated wing” WP A-2.2 as presented in the work breakdown structure here below.

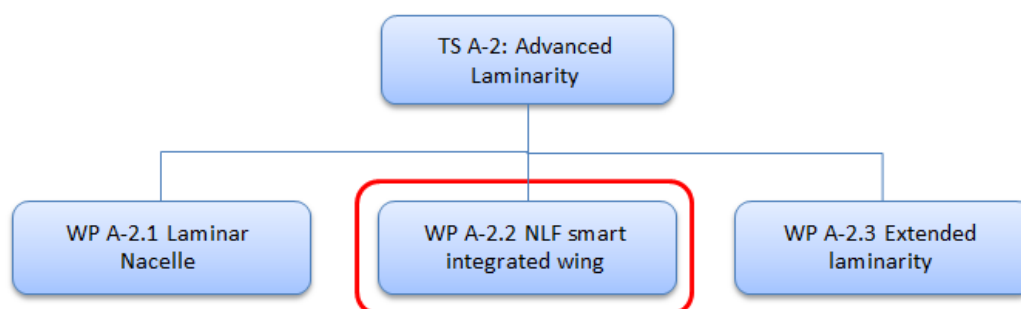

Figure 1 – WBS of ITD AIRFRAME –WP A-2: Advanced laminarity

Among the key parameters to ensure a successful laminar wing application on a commercial aircraft, anticontamination is one of the priorities. Therefore, the contamination must be avoided during take-off and initial climb, or the insects removed from the wing during climb.

Insect’s biochemistry, bio fluids rheology and complex interactions with surfaces and environmental conditions have been overlooked to a large extent. Without this knowledge, the development of anti-contamination solutions and low adhesion coatings cannot be precisely designed, targeting the key factors that cause the contamination of wings leading edge by insects.

The contribution of this call is to understand the root causes of wing contamination by insects, and subsequently propose more efficient anticontamination and/or low adhesion coatings and fluids.

2. Scope of work

This CfP aims first at understanding the insect’s hemolymph composition and interaction with its environment. This fundamental activity will provide the knowledge to further develop innovative anti-contamination solutions.

Secondly, the applicant must design its solutions keeping in mind that they must be environmentally friendly. The applicant shall also take into account the aerodynamic pressures and erosion phenomenon, especially strong at the leading edge nose where rain, hail, dust ice crystals and various particles are the most aggressive.

Tasks		
Ref. No.	Title - Description	Due Date
1	Management, coordination & report	T0+23
2	Survey and report of previous work and publications	T0+1
3	Biochemical modification of hemolymph	T0+13
4	Identification of physico-chemical key factors of surface contamination	T0+9
5	Development of surface coating solutions	T0+17

Tasks		
Ref. No.	Title - Description	Due Date
6	Development of self-repairing slippery surface	T0+17
7	Development of pre or post contamination cleaning solution	T0+17
8	Wind tunnel test, erosion test and flight test of the developed anticontamination and cleaning solutions	T0+29

Task 1: Management, coordination & report

The applicant will manage and coordinate the project and ensure due course of the project by respecting deliverables and milestones. Report will be made towards the Topic Manager weekly via emails, WebEx or face to face meetings. The milestone reviews will be every five to six months, preferably in face to face meetings

Task 2: Survey and report of previous work and publications

A lot of works has already been done on anti-contamination or low adhesion coatings/surfaces. The world of insects is studied in its many aspects because of the extraordinary capabilities they show from which the industry inspires. Plants also show a variety of properties at their surface that can be of interest for the purpose of this CfP.

Then, a deep review of past and present publications must be performed, in order not to miss scientific works that would report interesting results.

Task 3: Biochemical modification of hemolymph

The interaction between the hemolymph and its environment must be performed, as an aircraft taking off sees a very rapid change in speed, temperature, pressure and also humidity. All these factors and their combination have a major influence on the hemolymph behaviour.

Here below a non-exhaustive list of research/investigations to be conducted:

- Understanding the effect of temperature change at take-off and landing on the hemolymph properties
- Understanding the effect of pressure change at take-off and landing on the hemolymph properties
- Understanding the effect of humidity content at take-off and landing on the hemolymph properties
- Understanding the influence of the hemolymph previous state on its mechanical and chemical properties

Task 4: Identification of physico-chemical key factors of surface contamination

The interaction between hemolymph and the surface of the wing is the second phase leading to the comprehension of its properties.

Here below a non-exhaustive list of research/investigations to be conducted:

- Understanding hemolymph transformation in surface contamination/adhesion.
- Identification of physico-chemical properties of wing surface having a major influence on contamination.
- Conclusion of tasks 3 and 4 with clear identification of key factors to target the development of anticontamination, low adhesion coatings and fluids in next phases.

Task 5: Development of Surface coating solutions

At the light of both the survey conducted in task 2 and the conclusions of task 4, the applicant shall conduct:

- Evaluation of already known or tested coatings: Eventually, an already existing coating could be



improved to target an ideal rate of decontamination as close as it can be to 100% and for a long period of time as much as five years in companies. Today, the best coatings – when new - show a reduction of only 40% of contamination.

- Development of a new surface coating(s).

Task 6: Development Self repairing surface

To resist the aggressive environment the leading edge encounters in various atmospheric conditions, there can be two strategies: erosion resistance with stainless steel, or self-repair surface which is the only one able to also embed a low adhesion or anticontamination function. Mother Nature provides examples such as lotus leaf or lizard skin, the first being water repellent, the second self-repairing. The applicant must develop a surface that would combine both qualities. The self-repairing surface should last at least five years in companies.

The activity here will consist in the development of a Self-repairing surface combined with anti-contamination/low adhesion properties.

Task 7: Development of pre or post contamination cleaning solution

Tests with de-icing fluids used in winter to clear the wings of commercial jets have shown very good anti-contamination properties. But their formulation is based on ethylene glycol and therefore is not environmentally friendly.

The activity in this task will then consist on the development of pre or post contamination cleaning solution which must be environmentally friendly

Task 8: Wind tunnel test and/or flight test of the developed anticontamination and cleaning solutions

The validation of results will be partially achieved in lab -with particular attention to erosion tests- and wind tunnel tests, but final long duration tests on aircrafts will bring definitive answers.

- Lab tests: Mimic the rapid changes of atmospheric conditions corresponding to the climb and landing phases, and their influence of the insect's hemolymph properties.
- Wind tunnel tests: Shooting of a variety of insects on a leading edge mock-up with a dynamic pressure corresponding to take-off/ climb and landing phases.
- Erosion tests: Various samples tested in lab under different erosion agent such as water, sand, ice crystals.
- Flight tests Short duration: Installation of various test samples on the leading edge of a flight test aircraft. Fly in conditions favourable to the presence of insects in order to collect a maximum density of contamination on the leading edge. Compare the contamination of test samples areas with normal areas of the leading edge.
- Flight tests long duration: Installation of the most efficient anticontamination solutions on a localised area of the leading edge of a commercial aircraft. Regular control of the anticontamination surface efficiency and condition.

3. Major Deliverables/ Milestones and schedule (estimate)

*Type: R=Report, D=Data, HW=Hardware

Deliverables			
Ref. No.	Title - Description	Type*	Due Date
1	Literature survey résumé on low adhesion surface, anti-contamination and hemolymph properties.	R	T0+1
2	Biochemical modification of hemolymph.	R,D	T0+13

Deliverables			
Ref. No.	Title - Description	Type*	Due Date
3	Identification of physico-chemical key factors of surface contamination.	R,D	T0+9
4	Development of surface coating solutions Hardware: Surface coating applicable on a wing leading edge external surface. Should be erosion resistant (at least five years in companies) and environmentally friendly.	R,D,HW	T0+17
5	Development of self repairing surface Hardware: Self repairing surface applicable on a wing leading edge external surface. Should be erosion resistant (at least five years in companies) and environmentally friendly.	R,D,HW	T0+17
6	Development of pre or post contamination cleaning solution. Hardware: Cleaning solution.	R,D,HW	T0+17
7	Wind tunnel test, erosion test and/or flight test of the developed anticontamination and cleaning solutions. Hardware: Prototypes for tests.	R,D,HW	T0+17 & T0+29

Milestones (when appropriate)			
Ref. No.	Title - Description	Type*	Due Date
0	Project launch: review of scope and schedule	R	T0
1	Review and closure of task 2.	R	T0+1
2	Launch of activity 6	R	T0+2
3	Mid-activity review of tasks 3 & 4	R,D	T0+4
4	Launch of activities 5 & 7	R	T0+5
5	Review and closure of task 4. Temporary conclusion waiting for the end of task 3	R,D	T0+9
6	Launch of task 8	R,D,HW	T0+11
7	Review and closure of task 3	R,	T0+13
8	Mid-activity review of task 8	R,D	T0+16
9	Review and closure of tasks 5, 6 and 7.	R,D,HW	T0+17
10	Review and closure of task 8. Conclusion and long term endurance and erosion tests start.	R,D,HW	T0+29

A proposed schedule of tasks is illustrated below:

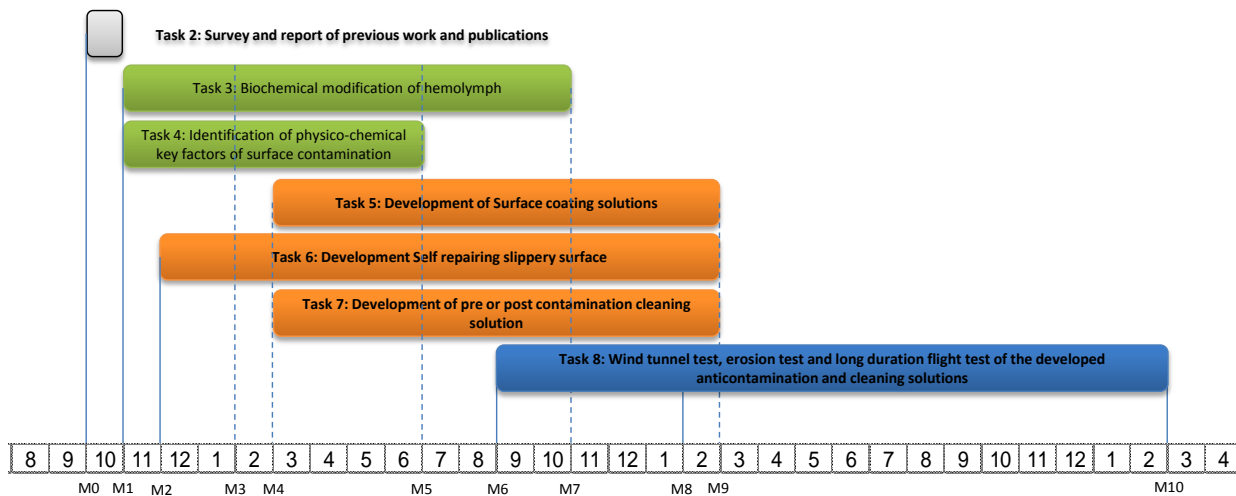

4. Special skills, Capabilities, Certification expected from the Applicant(s)

Proven experience in:

Special skills:

Materials and complex fluids (soft matter):

- Adherence
- Flow of complex fluids
- Glasses and slow dynamics
- Multi-scale mechanical properties
- Visco-Elasticity

Physical-Biology-medicine-interface:

- Mechanics of cells and tissues
- Nanohyperthermia
- Tissue engineering
- Morphogenesis
- Magneticnanoparticles
- Intracellular Nanorheology

Non linear physics:

- Acoustics
- Wetting, capillarity
- Hydrodynamics

Complex System Modeling and Engineering for Diagnosis:

- Complex system dynamic modeling
- System biology
- Bioware, programmable bio-machines
- Synthetic biology

Capabilities:

- Research lab with equipment and instrumentation related to the here above skills.
- Production of prototypes to be wind tunnel tested and to be assembled on a flight test aircraft .



5. Abbreviations

A/C Aircraft

II. JTI-CS2-2018-CFP09-AIR-02-68: Spring-in prediction capability for large integral composite wing structure [SAT]

Type of action (RIA/IA/CSA):		IA	
Programme Area:		AIR [SAT]	
(CS2 JTP 2015) WP Ref.:		WP B-1.2	
Indicative Funding Topic Value (in k€):		750	
Topic Leader:	Israel Aircraft Industries	Type of Agreement:	Implementation Agreement
Duration of the action (in Months):	14	Indicative Start Date (at the earliest)⁵⁸:	Q3 2019

Topic Identification Code	Title
JTI-CS2-2018-CFP09-AIR-02-68	Spring-in prediction capability for large integral composite wing structure [SAT]
Short description	
Composite material manufacturing process induced deformation such as spring-in may cause severe tolerance challenges for the assembly of aero-structures. This phenomenon becomes a major issue for large complex structures such as an integral wing box. The objective of this topic is to provide a numerical approach to be able to predict the spring-in phenomenon for an integral 7 meter wing box structure. A small scale integral demonstrator (1.2-1.5m) manufactured by the topic leader will be used to help calibrate and verify the approach.	

Links to the Clean Sky 2 Programme High-level Objectives⁵⁹				
This topic is located in the demonstration area:		Advanced Manufacturing		
The outcome of the project will mainly contribute to the following conceptual aircraft/air transport type as presented in the scene setter:		19-pax Commuter		
With expected impacts related to the Programme high-level objectives:				
Reducing CO₂ emissions	Reducing NO_x emissions	Reducing Noise emissions	Improving EU Competitiveness	Improving Mobility
<input checked="" type="checkbox"/>	<input type="checkbox"/>	<input type="checkbox"/>	<input type="checkbox"/>	<input type="checkbox"/>

⁵⁸ The start date corresponds to actual start date with all legal documents in place.

⁵⁹ For further info see Chapter 1 "Introduction to the Programme Scene Setter / Objectives" with key technology themes / demonstration areas. Detailed information available in the CS2 Development Plan accessible via the Clean Sky JU Website and EC Participant Portal.

1. Background

OPTICOMS is an AIRFRAME ITD core partner project under the Clean Sky 2 programme devoted to the research and development of technologies for more affordable composite aero structures. The consortium consists of a small aircraft OEM and three leading European aerospace automation companies, all striving towards low cost composite material automation for low volume aircraft manufacture. OPTICOMS is advancing a wide range of technologies with an emphasis on improvement of low cost and efficient production capabilities. Reducing manufacturing costs can be achieved by developing and implementing automated manufacturing processes together with designing integral structure. The cost effectiveness parameters shall be based on low volume production of small aircraft. The project will design, manufacture and test a full scale composite wing structure. The goals of the OPTICOMS project are consistent with WP B-1.2 of the AIRFRAME ITD (see figure 1 below) as described in the Clean Sky Joint Technical Program.

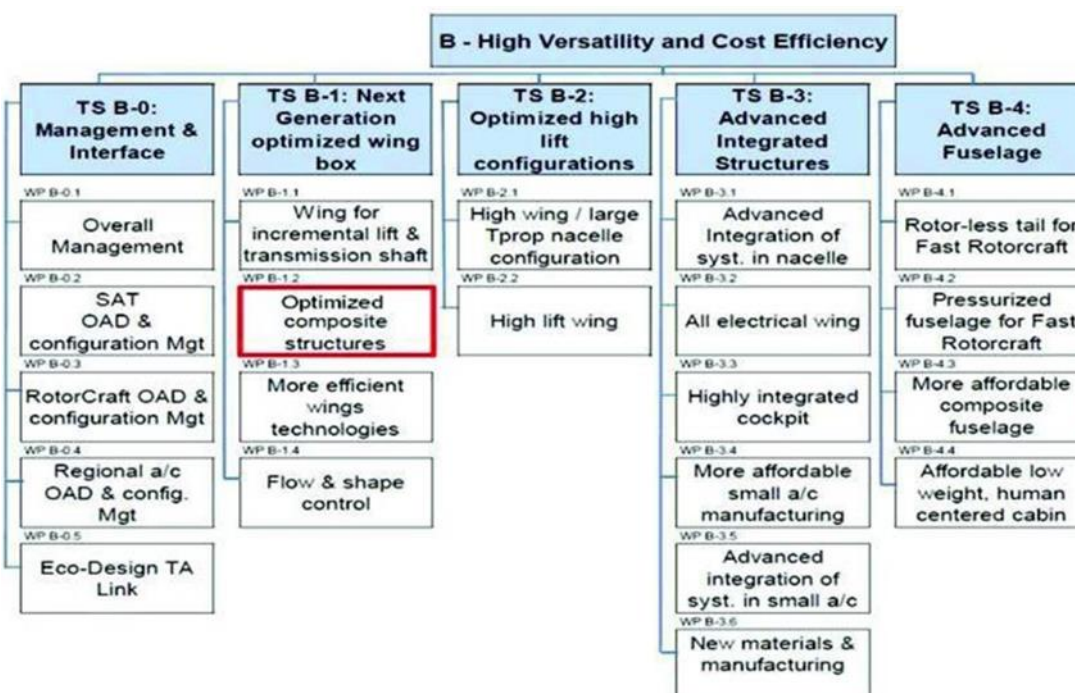

Figure 1 – WP B-1.2 collocation under AIRFRAME ITD

OPTICOMS included a large wing conceptual design down-selection phase which concluded with the wing design presented in Figure 2. Note that the 3 spars and the upper skin will be produced as an integral part. The idea of all the spars and skin being manufactured in a "one shot" integral process will significantly reduce manufacturing and assembly recurring costs. OPTICOMS focuses on both pre-preg and Liquid Resin Infusion (LRI) manufacturing.

Process induced deformations such as spring-in often occur even in the simplest structures. This phenomenon becomes a major issue for the large complex structure such as integrated manufactured wing box during the final assembly. Therefore, the objective of this topic is to examine the spring-in behavior of integrated composite wing structure (co-cured 3 spars and upper skin). Optimum numerical modeling will be chosen and/or developed. Key parameters which influence the spring-in must also be studied. Verification of the methodology will be based on a small scale integral demonstrator (provided by the topic leader). The main outcome of this topic is to provide a method of analyzing/simulating the

spring-in phenomenon for integral structures based on the design, materials and process developed within the OPTICOMS project.

In this topic, the spring-in simulation will be studied for both an infused composite structure as well as a pre-preg structure. Materials will be dictated by the material systems used in the OPTICOMS project. (Dry fibers infused with resin: Hi tape UD HTS fiber + RTM6-2 or NCF fabric + EP2400, pre-preg: Toray 2510).

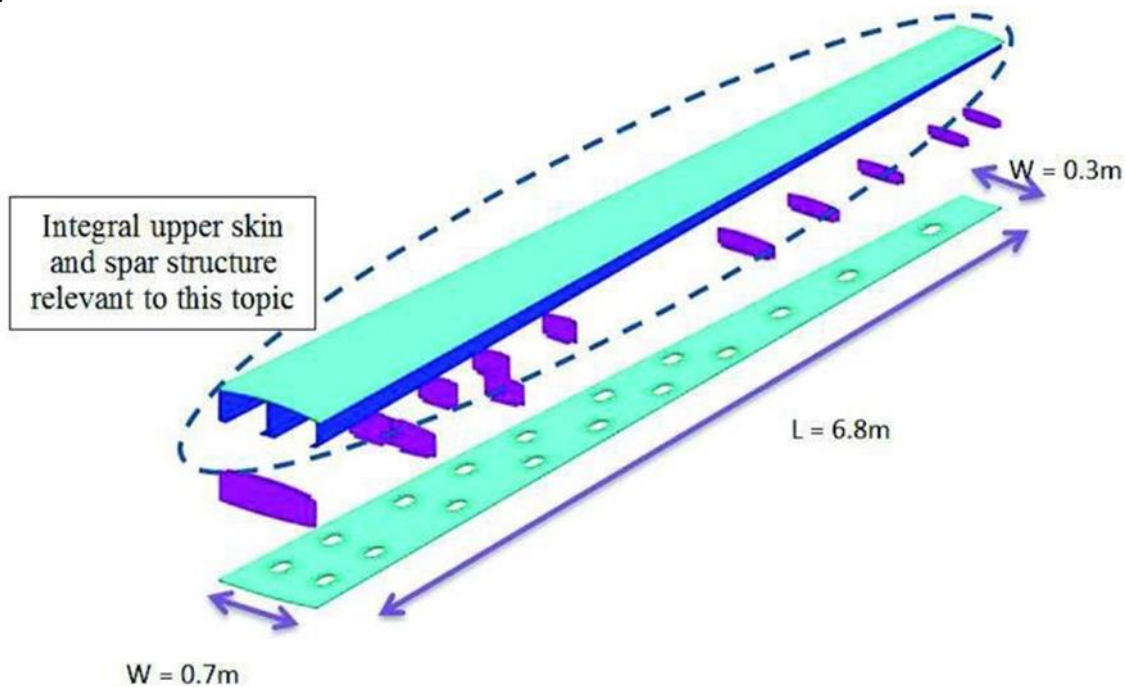

Figure 2 - Down-selected Integral Composite Wing Design Concept

With the present state-of-the-art, various approaches exist regarding the estimation of the spring-in phenomenon. The innovation expected in this topic is the ability to give a reasonable prediction for a large integral composite material structure, for a given material system and manufacturing process. In this topic, we want the applicant to improve and/or calibrate existing tools, or independently develop a simulation tool for predicting the spring-in of the large integral composite wing box structure. This will be attuned and applied specifically to the OPTICOMS 7M wing structure (see figure 2), but the improved spring in simulation tool should be reasonably applicable to other large complex structures. Various dominant parameters which effect spring-in should be studied and verified by small scale testing. Finally, the resulting numerical tool should help in providing guidelines to the OPTICOMS project on how to try to reduce the spring-in phenomenon for their complex, “one shot” full scale integral co-cured spar and skin structure.

2. Scope of work

This topic is requesting improved spring-in prediction capability for large integral wing structure. The overall goal is to understand the sources of the spring-in caused during the manufacturing process and provide a numerical model approach to simulate and guidelines to help alleviate the phenomenon. The critical parameters shall be defined, understood, simulated and validated.

The project shall start with a survey of the state of the art methods used today for calculating spring-in, concluding with an understanding of the most promising approach. The second phase will be

implementing, adjusting or developing promising methodology and numerical tools for analyzing the spring-in phenomenon. The resulting numerical approach shall be verified by smaller specimens using both pre-preg and LRI coupons. Finally a sub scale integral demonstrator (approx. 1.5 meter) manufactured by the topic leader to be representative of a “slice” of the OPTICOMS full scale 7M partial wing box integral structure (skin and spars) will be used to further verify and calibrate the simulation tool.

As part of the applicant’s comprehensive approach to understand and simulate the spring-in effect, the major parameters which effect the phenomenon shall be studied and understood such as the tooling material, lay-up sequence and balance, curing process, geometry (curved skins, C or I spars), etc. These parameters shall be derived, understood and calibrated by multiple “spring-in” coupon testing. Finally the applicant, with his improved numerical approach, will simulate the spring-in for the OPTICOMS 7M integral structure demonstrator and make suggestions to improve, reduce or compensate for the spring-in phenomenon.

The main tasks to be performed are as follows:

Tasks		
Ref. No.	Title - Description	Due Date
T1	Preferred Spring-in simulation method: Survey of available spring in simulation methods. Optimum simulation approach will be chosen, improved and/or further developed	T0+5
T2	Coupon manufacturing and testing There are 2 main purposes for the coupon testing: to understand the dominant factors which effect the spring-in phenomenon (tooling material, lay-up sequence and balance, curing process, geometry, etc.). These parameter effects will be incorporated into the Spring-in simulation tool to verify that the simulation tools ability to predict spring-in for a variety of conditions The coupon testing shall be performed for both pre-preg and LRI specimens, with the material systems defined in the OPTICOMS project and mentioned above. This task should start before finishing T1 above	T0+10
T3	Further Validation of numerical model The topic leader will provide a down scale (approx 1.5M) demonstrator representing a section of the integral OPTICOMS 7M wing box. The applicant will use his simulation approach to predict the spring-in for this structure and thus validate/calibrate his numerical approach.	T0+12
T4	Implementation of the chosen simulation approach to the full OPTICOMS 7M wing-box demonstrator Results of T1, T2 and T3 above will allow the applicant to analyse the spring-in for the full 7M OPTICOMS wing box demonstrator and to suggest improvements to minimize the expected spring in phenomenon.	T0+14

3. Major Deliverables/ Milestones and schedule

*Type: R=Report, D=Data, HW=Hardware, SW = Software

Deliverables			
Ref. No.	Title - Description	Type*	Due Date
D1	Report on the chosen simulation approach	R	T0+5
D2	Coupon test verification of simulation tools including effects of parameters	R	T0+10
D3	Spring-in software simulation tool. If it is based on commercial software package, all material data, calibrations, adjustments, fine-tuning and parameter modifications should be documented and provided.	SW	T0+14
D4	Spring-in calculation for 7M demonstrator with suggestion on how to reduce or compensate the phenomenon	R	T0+14

Milestones (when appropriate)			
Ref. No.	Title - Description	Type*	Due Date
M1	Spring in prediction software chosen/developed/modified/improved/provided	R	T0+5
M2	Completion coupon testing	D	T0+10
M3	Suggestion on how to reduce spring-in for full scale OPTICOMS demonstrator	D	T0+14

4. Special skills, Capabilities, Certification expected from the Applicant(s)

- Numerical Capabilities to calculate complex deformation and residual stresses
- Coupon test manufacturing and testing capabilities
- Understanding of complex composite material behavior

5. Abbreviations

ITD	Integrated Technology Demonstrator
LRI	Liquid Resin Infusion
OEM	Original Equipment Manufacturer

III. JTI-CS2-2018-CFP09-AIR-02-69: Biphasic Heat Transport integration for efficient heat exchange within Composite materials Nacelle

Type of action (RIA/IA/CSA):		RIA	
Programme Area:		AIR	
(CS2 JTP 2015) WP Ref.:		WP B-2.1	
Indicative Funding Topic Value (in k€):		800	
Topic Leader:	Airbus Defence & Space	Type of Agreement:	Implementation Agreement
Duration of the action (in Months):	30	Indicative Start Date (at the earliest)⁶⁰:	Q3 2019

Topic Identification Code	Title
JTI-CS2-2018-CFP09-AIR-02-69	Biphasic Heat Transport integration for efficient heat exchange within Composite materials Nacelle
Short description	
The topic scope is to validate the technology required for the integration of a cooling system for Composite nacelle based on biphasic heat transport where the hot source is a liquid and the cold sink is a nacelle external surface including Ice Protection applications. This topic include definition, material selections, composite material characterization under heat cycles, manufacturing and test of cooling system and its Nacelle integration. The Ice Protection Application shall be demonstrated in Icing WTT.	

Links to the Clean Sky 2 Programme High-level Objectives ⁶¹				
This topic is located in the demonstration area:		Small Aircraft, Regional and Business Aviation Turboprop		
The outcome of the project will mainly contribute to the following conceptual aircraft/air transport type as presented in the scene setter:		Regional Multimission TP, 70 pax		
With expected impacts related to the Programme high-level objectives:				
Reducing CO ₂ emissions	Reducing NO _x emissions	Reducing Noise emissions	Improving EU Competitiveness	Improving Mobility
<input checked="" type="checkbox"/>	<input type="checkbox"/>	<input type="checkbox"/>	<input checked="" type="checkbox"/>	<input type="checkbox"/>

⁶⁰ The start date corresponds to actual start date with all legal documents in place.

⁶¹ For further info see Chapter 1 "Introduction to the Programme Scene Setter / Objectives" with key technology themes / demonstration areas. Detailed information available in the CS2 Development Plan accessible via the Clean Sky JU Website and EC Participant Portal.



1. Background

There are numerous heat sources in present powerplant nacelles where the heat is not reused and evacuated by using heat exchangers typically cooled by external air, making the energy management very poor. This situation can be even more complicated and heavier by the need of active control of the external air flow with actuators.

Taking heat from available sources that need to be cooled (for example, engine or electrical generator oil) and driving it to nacelle cowlings and/or surfaces where heating is required (i.e. ice protected surfaces like engine air intake) will help to reduce the size of traditional heat exchangers by extracting part (or all) the heat and, in consequence, the nacelle weight and the RAM air required for cooling purposes, which, in the end, results in an increased efficiency compared to traditional designs.

Two-phase capillary heat transport technology has been developed for space applications but its application is clearly feasible to aircraft propulsion systems by adaptations on qualification and design (working fluid, capillary pumping capability). In this sense, it can be used as a way to recover waste energy from A/C (sub) systems and/or components, resulting in an increase of the efficiency of the overall heat exchange throughout the whole nacelle.

In addition, it is believed that use of biphasic capillary heat transport will allow for an optimum space allocation of propulsion system components due to the fact that the elements are downsized. As result, the nacelle is configured as slim format, thus reducing the aerodynamic drag, resulting in better efficiencies compared to traditional configurations.

This Call for Proposal (CfP) intends to use biphasic capillary system with a challenging approach; using hot liquid (oil) as heat source, nacelle composite material as coolant surface and with a dual usage (ice protection in icing conditions and cooling in any condition).

2. Scope of work

The objective of this CfP is to define and test a prototype, and validate a two-phase capillary pumped heat transport technology application able to replace (totally or partially) the usual oil cooling ACOC heat exchangers. In addition, it has to be able to provide (whether in series or parallel with the oil cooling) ice protection in a full composite engine air intake. Qualification as well as maintainability shall be taken into account

For the cooling purpose, the condenser is to be integrated with the nacelle doors and cowls manufactured in composite structure exposed to external air. The following design conditions are to be considered (Airframe ITD FTB#2 platform demonstrators used as reference):

cowls (maximum surface about 4 m²) exposed to external air at -30C, 25 kft pressure altitude and 0.5 Mach number,

heat transport capability of about 50 kW,

maximum engine oil outlet temperature will not exceed 120 deg C provided the inlet is controlled at about 90 deg C,

two phase system shall be able to operate from a soak ambient temperature at -55 deg C

The system will heat up an engine intake while flying in icing conditions (CS-25 Appendix C as reference).

The intake will be of chin type consisting of a lip and a duct with a total heated surface of 0.93 m² with maximum heating density of 20 kW/m² and maximum heating total heating power of 8 kW.

The following schematic represents the abovementioned configuration.

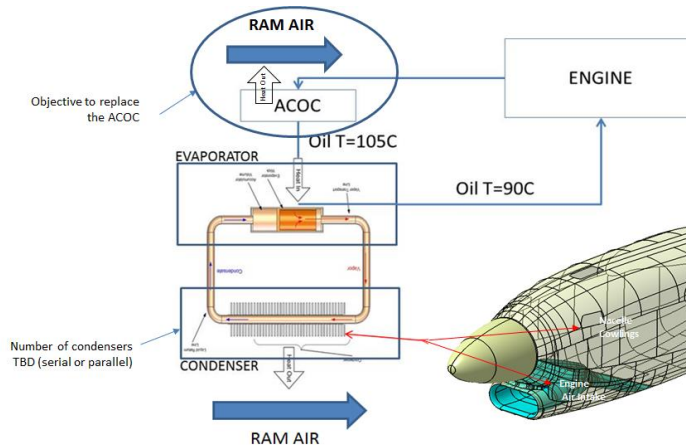

The technology challenge is to obtain a system in compliance with the requirements. The different steps are as follows:

Develop the concept. Analysis of the system viability to comply with the heat source requirements and with the sink requirements (both cooling and ice protection) including determination of the best composite material configuration to serve as a condenser. To note that cowlings must be also fireproof (intake is sufficient to be fire resistant) per ISO 2685. The concept shall include flexible ducting and disconnection points between evaporator and condenser.

Manufacture of prototypes (as a minimum of oil evaporator heat exchanger and of cowling heat sink condenser) of the concept and validate the analysis of viability by Laboratory tests,

Qualification tests to show compliance with the aircraft high level environmental requirements including characterization under heating cycles of the composite structure.

Two-phase heat transport system prototype testing in a real environment simulator representative of flight dry and icing conditions. The environment simulator (icing wind tunnel) is part of the Proposal.

A strong interaction with the Topic Manager is planned to ensure integration in a real aircraft surface which reduces the engine fuel consumption. The global scope of the technological line is a system validated at TRL5. It is proposed to organize the activities as follows:

Tasks		
Ref. No.	Title – Description	Due Date
WP1	Detailed specification in collaboration with Topic Manager. Design of concept suitable for installation including interfaces of key elements (evaporator / condenser), materials (including cowling and intake), working fluid and environmental conditions	T0+8
WP2	Integration to nacelle systems, considering the thermal distribution and heat exchange efficiency optimization, heating power for ice protection resulting into a system design.	T0+15
WP3	Manufacturing of prototype heat transport devices and testing for qualification, performances and maintainability compatible with nacelle environment (including characterization under heat cycling of the condenser structure)	T0+20

WP4	Integration tests for consolidation and verification of the design in test benches representative of geometry and environmental conditions (including icing), resulting into a qualification evidence	T0+30
-----	---	-------

A more detailed list of activities is included here below:

WP1

- Development of system to show the viability.
- Analysis of the requirements: temperatures, geometry, interfaces, weights, etc.
- Initial design of the evaporator with the heat source
- Initial design for the condenser with the cold sink

Inputs from Topic Manager at T0 will be: geometry, hot source, cold sink, system and definition of nacelle surface for prototype.

WP2

- Detailed design of the evaporator with the heat source
- Detailed design for the condenser with the cold sink.
- Size and detailed design of the completed system.
- Mechanical analysis of the detailed design.
- Completed system modelled and performance simulation

WP3

- System prototype design to be tested as validation of the concept.
- Design the needed tools to manufacture it.
- Modelling of the prototype and test results predictions
- System prototype to validate concept manufacture
- Integration of the prototype with a nacelle surface prototype.
- Test plan
- Test of the System prototype
- Analysis of the test results

WP4

- Manufacture of the completed system prototype
- Integration of the system with the representative nacelle surface
- Test plan
- Analysis of the test results and conclusions

The wind tunnel campaign in dry air and icing conditions shall include as a minimum the following test points.

<i>Test Point</i>	<i>External Temp (deg C)</i>	<i>External LWC (grm/m3)</i>	<i>External Airspeed (m/sec)</i>	<i>Intake Airflow (Kg/sec)</i>	<i>Source Temp (deg C)</i>
1	-30	0.2	100	4.5	120->100->80
2	-30	1.0	100	4.5	120->100->80
3	-30	1.0	100	3.0	120->100->80

Test Point	External Temp (deg C)	External LWC (grm/m3)	External Airspeed (m/sec)	Intake Airflow (Kg/sec)	Source Temp (deg C)
4	-10	2.2	100	9.0	120->100->80
5	-10	0.5	100	5.0	120->100->80
6	-10	2.2	100	5.0	120->100->80
7	45	0.0	0	4.0	120->100->80
8	45	0.0	10	4.0	120->100->80
9	45	0.0	50	6.0	120->100->80

The proposal shall cover design, manufacture and test of a complete system. Different models, techniques and associated software shall be used to simulate the behavior of the two-phase heat system. Activities must be carried out using accurate tools and models to analyze the two phase heat transport. The detailed thermal and mechanical analysis of the coupling between the two-phase heat transport system and the interfaces (Powerplant installation) shall be carried out with Finite Element codes (i.e. ANSYS, NASTRAN, etc.).

3. Major Deliverables/ Milestones and schedule (estimate)

*Type: R=Report, D=Data,HW=Hardware

Deliverables			
Ref No.	Title – Description	Type*	Due Date
D1.1	Initial System Design Report	R	T0 + 8
D2.1	System Design Report	R	T0 + 15
D2.2	System Thermal Model	R	T0 + 15
D2.3	System FEM Model	D	T0 + 15
D3.1	System Prototype	HW	T0+20
D3.2	Test Plan	R	T0+20
D3.3	Test Report	R	T0+20
D4.1	Integrated System Prototype	HW	T0+25
D4.2	Test Plan	R	T0+25
D4.3	Test Report	R	T0+30
D4.5	Final System Design Report	R	T0+30

Milestones			
Ref. No.	Title - Description	Type*	Due Date
M0	Conceptual Design Review	R	T0+4
M1	Preliminary Design Review	R	T0+8
M2	Critical Design Review	R	T0+15
M3	Test Readiness Review	R	T0+25

4. Special skills, Capabilities, Certification expected from the Applicant(s)

- Experience in aeronautics systems and structures
- Knowledge and experience in CFD and coupled simulations (i.e. thermo-mechanical)
- Engineering software and licenses for CAD/CAE, CFD



- Participation in R&T projects by cooperating with industrial partners.
- Experience in technological research and development in heat transfer devices.

An Implementation agreement will be proposed to manage the IPR and the relation between the Topic manager and the Applicant(s).

5. Abbreviations

ACOC	Air Cooler Oil Cooled
CAD	Computer Aided Design
CAE	Computer Aided Engineering
CFD	Computational Fluid Dynamics
FEM	Finite Element Model
IPR	Intellectual Property Rights
IWT	Icing Wind Tunnel
R&T	Research & Technology

IV. JTI-CS2-2018-CFP09-AIR-02-70: Development and application of an innovative methodology devoted for high temperature characterization of high efficient composite structures

Type of action (RIA/IA/CSA):		RIA	
Programme Area:		AIR	
(CS2 JTP 2015) WP Ref.:		WP B-2.1 & B-2.2	
Indicative Funding Topic Value (in k€):		700	
Topic Leader:	Airbus Defence & Space	Type of Agreement:	Implementation Agreement
Duration of the action (in Months):	24	Indicative Start Date (at the earliest)⁶²:	Q3 2019

Topic Identification Code	Title
JTI-CS2-2018-CFP09-AIR-02-70	Development and application of an innovative methodology devoted for high temperature characterization of high efficient composite structures
Short description	
The topic deals with the monitoring, characterization and prediction of high temperature events on innovative composite structures, based on composite configurations oriented to high service temperature application (thermosetting and ISC thermoplastic), and the corresponding correlation and validation by representative specimens testing. It is included the design, development and installation, of a most efficient and innovative configurable ground test environment.	

Links to the Clean Sky 2 Programme High-level Objectives ⁶³				
This topic is located in the demonstration area:		Small Aircraft, Regional and Business Aviation Turboprop		
The outcome of the project will mainly contribute to the following conceptual aircraft/air transport type as presented in the scene setter:		Regional Multimission TP, 70 pax		
With expected impacts related to the Programme high-level objectives:				
Reducing CO ₂ emissions	Reducing NO _x emissions	Reducing Noise emissions	Improving EU Competitiveness	Improving Mobility
<input checked="" type="checkbox"/>	<input type="checkbox"/>	<input type="checkbox"/>	<input checked="" type="checkbox"/>	<input type="checkbox"/>

⁶² The start date corresponds to actual start date with all legal documents in place.

⁶³ For further info see Chapter 1 "Introduction to the Programme Scene Setter / Objectives" with key technology themes / demonstration areas. Detailed information available in the CS2 Development Plan accessible via the Clean Sky JU Website and EC Participant Portal.

1. Background

The framework of this topic is AIRFRAME ITD WPs B-2.1 and B-2.2 whose objective is to achieve lighter and more cost effective structures; in this line the current tendency at A/C level is to increment the more efficient composites structural contribution substituting metallic structures.

The scenario of large aircraft under CS25 certification leads to increasing thermal affection on the structure as the sector is moving to a more-electric aircraft with increasing number of potential heat & fire sources appear.

On the one hand new equipment is being required: batteries, EHA & EMA actuators, ice protection, E-braking & taxiing. This equipment may cause overheating and accidentally cause fire:

On the other, traditional heat sources & hazards (bleeding tubes, nozzle exhausts, engine & APU, fuel system...) are still present.



Battery heating issues on composite fuselage



Certification requirements for primary composite structure: flame affection

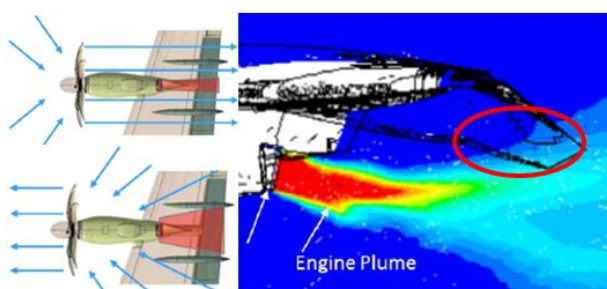

Flap support composite fairing exhaust plume affection on turboprop aircraft while taxiing



Certification of fire behaviour through test

As heat causes more damage on composites than on metallic counterparts, a harder Fire, Smoke & Fumes certification must be expected typically with expensive testing campaigns. In order to improve the current epoxy based composites behavior under thermal affection an alternative may be addressed: thermoplastic composites.

High performance thermoplastic-resin and carbon-fibre prepreps based on Polyaryletherketone (PAEK) family resins (including PEEK and PEKK polymers) are a promising technology for structural applications due to its recyclability, re-processability, reparability, theoretical infinite shelf life and its performance advantage in terms of mechanical properties in relation with current widely used thermosetting epoxy resins; more specifically the composite structures based on this materials are less hygroscopic and



sensitive to temperature in the typical operative range.

In contrast, due to its high fusion temperature, they have higher processing temperatures that make difficult its use spread. To deal with this drawback, new manufacturing techniques based in automatic fiber deposition and on line consolidation have been introduced, improving the cost advantage of thermoplastic in comparison with typical epoxy automated lay-up and autoclave common manufacturing.

Due to its potential, this material is being investigated in the scope of AIRFRAME ITD to become a part of a flying demonstrator.

The high fusion temperature and elevated glass transition temperatures of these thermoplastic structures make them suitable for high temperature application, specifically its use in fire prone or thermally demanded areas of the structure such as nacelle compartments, movable surfaces affected by engine nacelle exhaust or any other area of the structure affected by hot air exhaust impact.

2. Scope of work

The main objective of the call is to characterize the behavior under high temperature events, of thermoplastic composite materials based on PAEK family thermoplastic-resin and carbon-fibre monolithic composites, which are considered as a feasible option to withstand local thermal events that may affect primary or secondary airframe structures.

In order to ensure material thermal characterization, a model based virtual testing approach shall be proposed allowing cost reduction and agility in future A/C developments.

Related models developed for thermoplastic specimens characterization are going to be tuned and validated by testing at Topic Manager Fire Laboratory.

Typical high temperature events affecting large aircraft structures (beyond material glass transition temperature) are:

- Fire events on designated Fire zone as per CS/FAR 25.1181 and AC20-135 that require to sustain flame defined by ISO2685, under loaded state and with a duration of 5 or 15 minutes depending on its categorization (fire resistant or fire proof, defined in AC20-135). This short duration event (maximum 15 minutes) provides higher degradation as temperature may reach up to 900°C.
- Hot air exhaust on composite structure coming from engine nozzle or other hot air sources. These hot air exhausts or engine nozzle can be in a wide range of temperatures from 200°C to 500°C causing local temperatures in composites, depending on disposition, higher than glass transition temperature of PAEK family resins.

This event has typically a long duration, causing a degradation of the composite which may produce deformation and deconsolidation of the resins.

The first kind of events, fire, is especially critical for the fitting attachments into the composite, being commanded by the degradation of the resin in the surroundings of the individual joint; therefore, resin bearing and pull through properties during its degradation are determinant for this kind of structures.

The second one, hot air impact, is not necessarily critical for fitting attachments although riveted joints or metallic substructure can act as a nucleation location for internal damage as metallic structure reaches a higher temperature when heated by a hot air flow.

The objectives of the activity asked to the applicant are twofold:

- a) Provide an innovative testing lab environment capable of:
 - Monitor precisely thermal events including fire by innovative passive filtering techniques

applied to thermography.

- Characterize composite thermal properties by flash method or equivalent.
- b) Evaluate thermo-mechanical behavior of thermoplastic loaded structures submitted to fire and high temperature air exhausts.

The testing campaign to be performed may include:

- Thermal characterization for thermoplastic and reference materials, based on “Flash method” (ASTM E1461-01) or equivalent for both intact and degraded composite.
- Mechanical testing campaign:
 - Based on pull through and bearing tests to determine individual attachment strength of degraded areas after fire and high temperature exposition (>300°C) (AITM01-0009, AITM01-0066 or equivalent normative to be used). A reference based on thermosetting epoxy resin composite (8552/AS4 as reference) may be used for comparative analysis; a second reference may be established with protective gasket located in the joint.
 - Mechanical testing campaign performed at temperature beyond T_g (from 160° to 300°C depending on achievable conditions), with at least material lamina properties, in-plane shear modulus, bearing, pull-through, plain compression tests. (adapting current testing norms or equivalents: DIN_EN_2561&2567, AITM1-0002 / 0008 / 0009/ 0066 to the higher temperatures involved)
- Component scale testing of fire and high temperature events, both for the thermoplastic component and a reference thermosetting epoxy to be used for comparative analysis:
 - Fire tests to be performed under mechanically unloaded and loaded conditions and standard flame defined by ISO-2685
 - Hot airflow and loaded conditions. The conditions are to be agreed with Topic Manager.

The final evaluation of the thermoplastic comparative behavior under high temperature events would be performed by the analysis of test results and virtual testing approach.

A thermomechanical model approach is to be proposed - including thermal load, material model, and failure criteria - and fed by the thermal and mechanical characterization tests.

After model adjustment and correlation with test results, the model will be used complementarily to the direct test results analysis to evaluate the comparative performance of thermoplastic composites.

The modelling strategy shall focus specifically on high temperature exhaust impact and fire events, taking as an input the results of an ad-hoc material thermal properties characterization related to the specimen under test, by using methodologies based on thermography.

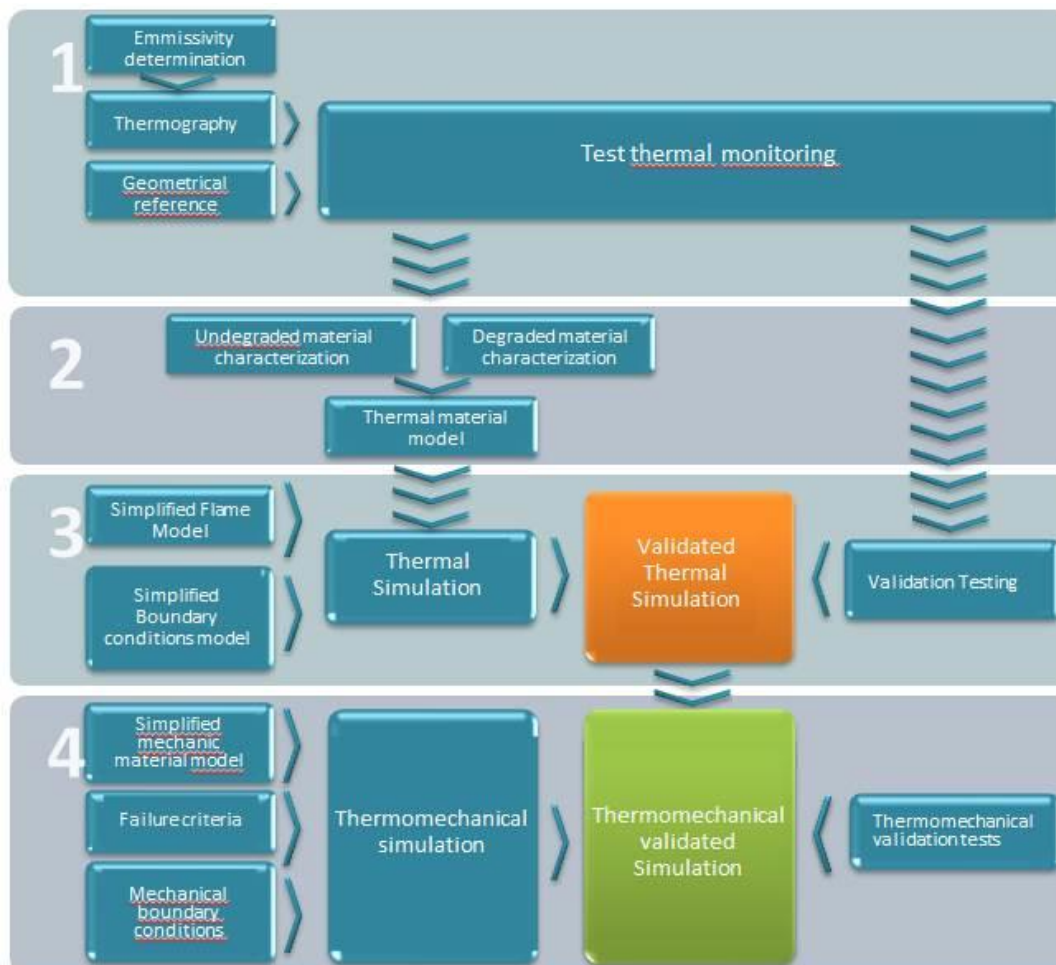

Figure 5. Modelling strategy

COMPONENT	TECHNOLOGY CHALLENGES	TECHNOLOGY DEMONSTRATORS
Thermoplastic composites	High temperature event characterization of PAEK family resin based thermoplastic-carbon fibre composites	Test analysis
Thermoplastic composites	Virtual test for high temperature events characterization	Model based approach and virtual testing
Test Lab	Innovative thermal excitation, characterization and monitoring capabilities	Thermal excitation, thermography at Fire Lab

Table 1: Technology challenges in the Flexible Test Rig for different A/C surfaces powered by EMAS

Work Packages and Tasks description

It is proposed to organize the activities in three technical Work Packages (WPs):

- WP1: Design, development and installation of an innovative ground test environment, over the existing Fire Lab at Topic Manager facilities at Getafe, which enables the generation and

measurement of high temperature events applied over standardized specimens. It may be considered the necessary means for generating and measuring temperature distribution at both cold and hot sides of the specimen. For this purpose, innovative solutions may be considered taking as a base point thermography and heating devices, to be installed at Fire Lab at Topic Manager facilities at Getafe.

- WP2: Test campaign, that will include the following activities:
 - Trade-off of different configurations of thermoplastic carbon composite materials to be tested and reference based on thermosetting to be considered as reference and to be tested if no background information is available.
 - Test matrix definition, considering the necessary thermal and mechanical characterization to provide inputs for model validation.
 - Specimens manufacturing
 - Test setup at Fire Lab at Topic Manager facilities, supporting test activities to be performed by Topic Manager.

- WP3: Analysis and correlation, considering the following activities:
 - Definition of a procedure for modelling and virtually test high temperature events on composites: thermal load model, material model based on thermal and mechanical characterization and failure criteria.
 - Test results analysis and development of a procedure for modelling high temperature events on composites
 - Models tuning by using test evidences
 - Validation of the representability/precision of the models (error)

Three batches of specimens manufacturing, testing and analysis have been considered, with enough time between them in order to ensure certain flexibility in the definition of the materials configurations to be considered for the next batch.

These Work-Packages shall be under the Applicant accountability; however the Topic Manager will contribute to the conceptual design, as well as the specific requirements.

In the following, technical tasks description and expected schedule are provided:

Tasks		
Ref. No.	Title - Description	Due Date
Task 1.1	Trade-off for selection of the industrial solutions for precise IR acquisition and filtering, and for high temperature events reproduction at specimen level.	T0 + 2
Task 1.2	PDR: preliminary design review	T0 + 3
Task 1.3	CDR: critical design review	T0 + 4
Task 1.4	IR Set and Thermal Source acquisition, manufacturing and assembly	T0 + 7
Task 1.5	Acceptance Test Procedure Execution at Fire Lab and Entry into Service	T0 + 9
Task 1.6	Support of testing activities	T0 + 24
Task 2.1	Trade-off of different configurations of Thermoplastics materials to be tested, and reference materials to be considered	T0 + 2
Task 2.2	Definition of the number of configurations to be tested and number of specimens to be manufactured	T0 + 2

Tasks		
Ref. No.	Title - Description	Due Date
Task 2.3	Specimens manufacturing (first batch)	T0 + 6
Task 2.4	Test campaign (first batch)	T0 + 10
Task 2.5	Specimens manufacturing (second batch)	T0 + 13
Task 2.6	Test campaign (second batch)	T0 + 15
Task 2.7	Specimens manufacturing (third batch)	T0 + 20
Task 2.8	Test campaign (third batch)	T0 + 21
Task 3.1	Definition of a procedure for modelling High Temperature Events on composites	T0 + 8
Task 3.2	First batch test results and correlation with model	T0+12
Task 3.3	Second batch correlation between models and test results	T0+17
Task 3.4	Third batch correlation between models and test results	T0 + 23
Task 3.5	Assessment and validation of the representativity/precision of the models (error)	T0 + 24
Task 3.6	Comparative evaluation of thermoplastic under high temperature events	T0+24

Additional relevant Requirements

- Additional testing capabilities –generation and measurement of high temperature events- shall be added to the existing Fire Lab test facility located at Topic Manager Getafe Site in order to ensure the realization of the related test campaign.
- Both cold and hot specimen sides temperature distribution need to be synchronised in time, and considering a position correlation between sides,
- Obtained data through IR image shall avoid the thermal effect of any component, substance, medium between the panel and the IR sensor (example: flame, gases, IR camera filters...)

Effort and costs

An estimation of the effort between activities is suggested below, but not compulsory.

COMPONENT/ACTIVITY	Effort estimated
WP1: Design, development and installation of a configurable ground test environment, over the existing Fire Lab, that enables it for the generation and measurement of high temperature events applied over standardized specimens	25%
WP2: Test campaign, that will include the following sub-WP:	50%
WP3: Analysis and correlation	25%

Table 2: Indicative effort required for each main component/activity within the project

Inputs and Outputs

- The Topic Manager will provide to the Beneficiary the Current Fire Lab specifications and description. In addition, he will support the activities defined in the Topic to ensure full-

compatibility of the rigs.

The outputs requested from the Applicant are the following:

- HW (IR solution and thermal source) to be installed at Fire Lab
- Specimens agreed to be manufactured for the three batches
- Technical documentation regarding to: ATP and test results of the added capabilities to the fire lab, procedure for modelling high temperature events on composites, test results analysis and correlation for the three batches
- Software code related to the modelling activities

In addition,

- The Applicant has the responsibility for the manufacturing of the specimens and to perform the mechanical testing. Fire and high temperature loaded and unloaded configurations will be tested at Topic Manager premises.
- The meetings for project monitoring will be held on a regular basis at Topic Manager premises. It is foreseen a meeting every three months.
- The applicant will work in close cooperation with the Topic Manager who will provide the adequate information and technical requirements. Further innovations and improvements and recommendations from specific studies and analysis proposed by the applicant will be welcomed.
- All the information and data to be exchanged between the Topic Manager and the Beneficiary of this CfP will be regulated under specific NDA and IPR regulations that will recognize mutually their property following the recommendations and directives of the CSJU.

3. Major Deliverables/ Milestones and schedule (estimate)

*Type: R=Report, D=Data, HW=Hardware

The deliverables and milestones due dates are in accordance with the general work plan of the AIRFRAME Work Packages B-2.1 and B-2.2 and linked with Regional Aircraft FTB2.

Deliverables			
Ref. No.	Title - Description	Type*	Due Date
D1.1	PDR: preliminary design review	R	T0 + 3
D1.2	CDR: critical design review	R	T0 + 4
D1.3	HW related to added capabilities at Fire Lab and the corresponding ATP Test Results	R + DW	T0 + 9
D2.1	Specimens First Batch Delivery	HW	T0 + 6
D2.2	First batch test recordings	D	T0 + 10
D2.3	Specimens Second Batch Delivery	HW	T0 + 15
D2.4	Second batch test recordings	D	T0 + 16
D2.5	Specimens Third Batch Delivery	HW	T0 + 20
D2.6	Third batch test recordings	D	T0 + 22
D3.1	Procedure for modelling High Temperature Events on composites	R	T0+8
D3.2	First Batch Test Results Analysis and Correlations	R+D	T0+12
D3.3	Second Batch Test Results Analysis and Correlations	R+D	T0+18
D3.4	Third Batch Test Results Analysis and Correlations	R+D	T0+23

Deliverables			
Ref. No.	Title - Description	Type*	Due Date
D3.5	Comparative evaluation of thermoplastic under high temperature events	R+D	T0+24
D3.6	Final Report	R+D	T0+24

Milestones (when appropriate)			
Ref. No.	Title - Description	Type*	Due Date
M1	Preliminary Design Review	R+D	T0+3
M2	Critical design Review	R+D	T0+4
M3	Entry into Service	R+D	T0+9
M4	1st batch specimen delivery	HW	T0+6
M5	2st batch specimen delivery	HW	T0+13
M6	3st batch specimen delivery	HW	T0+20
M7	1st batch Analysis and correlation	R+D	T0+12
M8	2st batch Analysis and correlation	R+D	T0+18
M9	3st batch Analysis and correlation	R+D	T0+23

4. Special skills, Capabilities, Certification expected from the Applicant(s)

- **R&T Management**
 - Management of complex R&T and industrial projects for aeronautical composite & metallic components by automated manufacturing processes.
 - Participation in international R&T projects cooperating with industrial partners.
- **R&T Methodology**
 - Fast track trial and error methodology.
 - Experience on simulations to reduce R&T lead time.
- **Design and Data Management**
 - Solid knowledge and capabilities for designing and manufacturing electronic test devices.
 - Solid knowledge of CATIA model design.
 - High competence for managing aeronautical 3D design software, structural analysis for composite materials lay up design and lay up simulation.
 - Strong Thermomechanical FEM competences.
 - Engineering software and licenses for Computer Aided Design (CAD), and appropriate high performance computing facilities.
- **Materials & Processes**
 - High experience on Thermoplastic and thermosetting manufacturing.
 - Experience on thermoplastic raw materials internal development.
 - Experience on fast Non Destructive Inspections.
 - Experience on material physico-chemical analysis.
- **Manufacturing**
 - Solid knowledge and capabilities for designing and manufacturing mechanical and electronic test benches.
 - High experience on Thermoplastic and thermosetting manufacturing.
 - Previous experience on aerospace manufacturing and assembly processes.
- **Testing**



- Experience in thermal characterization of composites
- Experience and qualification as mechanical lab for the indicated mechanical tests.
- Experience on high temperature and fire testing and monitoring.

5. **Abbreviations**

A/C	Aircraft
AC	Alternate current
CAD	Computer Aided Design
CB	Circuit Breaker
CDR	Critical Design Review
CfP	Call for Proposal
CISS	Customer Inspection at Suppliers Site
CS2	Clean Sky 2
CU	Control Unit
DC	Direct current
EMA	Electro Mechanical Actuator
FTI	Flight Test Instrumentation
ICD	Interface Control Document
I/O	Input/Output
JTP	Joint Technical Proposal
KOM	Kick off meeting
LH	Left Hand
PAEK	Polyaryletherketone
PDR	Preliminary Design Review
PDU	Power Distribution Unit
RCCB	Remote Controlled Circuit Breaker
RH	Right Hand
R&T	Research and Technology
SW	Software
TBC	To be confirmed
TRU	Transformer Rectifier Unit
WP	Work Package

V. **JTI-CS2-2018-CFP09-AIR-02-71: Model Manufacturing and Wind Tunnel Testing of High Lift System for SAT Aircraft [SAT]**

Type of action (RIA/IA/CSA):		RIA	
Programme Area:		AIR [SAT]	
(CS2 JTP 2015) WP Ref.:		WP B-2.2.3	
Indicative Funding Topic Value (in k€):		800	
Topic Leader:	Piaggio Aero	Type of Agreement:	Implementation Agreement
Duration of the action (in Months):	15	Indicative Start Date (at the earliest)⁶⁴:	Q3 2019

Topic Identification Code	Title
JTI-CS2-2018-CFP09-AIR-02-71	Model Manufacturing and Wind Tunnel Testing of High Lift System for SAT Aircraft [SAT]
Short description	
<p>The scope of work is the experimental verification of the capabilities of innovative high lift systems solutions developed for SAT. For the purpose, a wind tunnel entry is needed including the design and manufacturing of wing segment models with selected high lift devices at meaningful Reynolds number. A complete set of experimental data, surface pressure and wake measurements shall be built to determine forces and moments in different high lift configurations. In particular, PIV technique will be requested to evaluate fluidic devices by comparison with CFD computations.</p>	

Links to the Clean Sky 2 Programme High-level Objectives ⁶⁵				
This topic is located in the demonstration area:			Regional Aircraft Wing Optimization	
The outcome of the project will mainly contribute to the following conceptual aircraft/air transport type as presented in the scene setter:			19-pax commuter	
With expected impacts related to the Programme high-level objectives:				
Reducing CO₂ emissions	Reducing NO_x emissions	Reducing Noise emissions	Improving EU Competitiveness	Improving Mobility
<input checked="" type="checkbox"/>	<input type="checkbox"/>	<input type="checkbox"/>	<input type="checkbox"/>	<input checked="" type="checkbox"/>

⁶⁴ The start date corresponds to actual start date with all legal documents in place.

⁶⁵ For further info see Chapter 1 "Introduction to the Programme Scene Setter / Objectives" with key technology themes / demonstration areas. Detailed information available in the CS2 Development Plan accessible via the Clean Sky JU Website and EC Participant Portal.

1. Background

In AIR ITD WP B-2.2.3, the development of High Lift HL) devices for SAT (19 seat aircraft) is divided into two-research phases. The first phase consists in the selection and optimization of several innovative high-lift devices (Figure 1) for two types of SAT aircraft architectures. At the end of the integration/aerodynamic design, the activity will proceed with a cross-comparison of the benefit achieved for each high lift architecture, and then the most suitable of them will be down-selected.

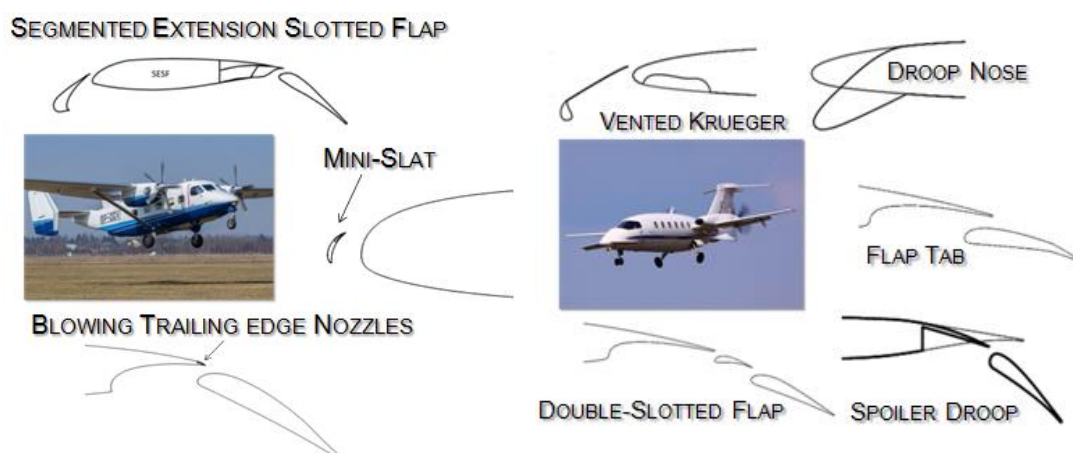

Figure 1 SAT reference aircraft

This topic will support the second phase of the work on high lift systems dedicated to SAT aircraft in which the selected solution will be tested in wind tunnel to validate the phase 1 design. The applicant must design and manufacture the segment of profile/wing model including high lift devices. The model must be equipped with pressure taps. Minimum 67 pressure measurement points must be located on the main wing of the model and minimum 33 pressure measurement points have to be set on the trailing edge devices. The wing-segment chord shall be sufficiently large to accommodate a sufficient number of pressure tabs on all small sub-elements like: mini-slat (at least 15 pressure points), Krueger flap (at least 15 pressure points) or Fowler flap (at least 40 pressure points). The geometry tolerance of model template manufacturing must be achieved in the range of 0.05% of basic chord of profile. These requirements recommend the selection of 2 meters span and 1-meter chord model to be built in aluminum alloy to guarantee the geometric tolerances.

The wind tunnel data acquisition equipment i.e.:

- force and moment balance
- pressure pipes
- pressure transducers
- data acquisition system

is in charge to the applicant.

Then, the model will be tested in wind tunnel. The plan of tests shall include all selected model configurations (slot deflection, flap deflection and/or position, etc.) in subsonic regime performing polar up to CL_{max} angle of attack and to Reynolds number at least of $5 \cdot 10^6$. An additional requirement will be the possibility to perform tests up to $6.5 \cdot 10^6$. The forces and moments, excluding drag force, on the model will be determined by using measurement of the pressure distribution on surface. The drag force must be obtained using pressure distribution in the wake. The visualization of flow field using PIV techniques will be an added value to the project.

The possible configuration of high lift systems includes also fluidic devices. Consequently, the wing

segment shall enable the mounting of a row of blowing nozzles at the main-wing trailing edge (see Figure 1). For this configuration, it is required to provide the intensity of blowing, expressed through dimensionless "blowing momentum coefficient" (C_{μ}) up to $C_{\mu} \approx 0.07$, where: $C_{\mu} = \frac{\dot{m} \cdot V_j}{q_{\infty} \cdot S}$, \dot{m} – mass flow rate, V_j – jet velocity, q_{∞} – free-stream dynamic pressure, S – reference area of wing segment. For such investigations it is necessary to provide the smooth control of the mass flow rate of air blown through the nozzles.

During the test the optimal relative position of main part and high lift elements shall be determined. PIV measurements shall be performed during the tests especially for the flow analysis for fluidic devices to generate a data base for CFD comparison and cross validations.

2. Scope of work

The main goal of the project is to assure the performance of the innovative high lift device for SAT aircraft. The goal will be reached in experimental way through wind tunnel test. To achieve it the following activities must be done:

- design of wind tunnel model for selected high lift concepts. The model will be composed by several parts depending on the selected high lift configuration. At the moment, the part number cannot be exactly defined but it seems reasonable it should not exceed three main parts (a main wing, a slat, a flap) and a number of minor parts depending on the complexity of the selected solution.
- model manufacturing (it shall be in aluminium alloy CNC manufactured) and its test equipment setting up to serve the specifications of pressure, drag and flow field measurements through PIV technique.
- carry out of experimental test of model in wind tunnel consisting in one subsonic polar for each configuration model to get data to assess the different configurations and to optimize the relative positions of high lift components.

Tasks		
Ref. No.	Title – Description	Due Date
WP 1	Model Design - Design of wind tunnel model of the high lift selected concept: - Technical solution to link the model to test rig - Technical solution to install all the pressure taps and the needed instrumentations - Aero-load computation and model structural design - Model drawings and CNC pattern design.	T0 + 6
WP 2	Model Manufacturing - Model CNC manufacturing and equipment set up. - Tolerance Geometrical checks	M2 + 10
WP 3	Wind Tunnel Tests - Wind tunnel test run on the selected configuration according with the specified plan. - Record of uncorrected and corrected force and moment data. Pressure measurement. - PIV pattern measurement.	M10 + 4
WP 4	Experiment Assessment The analyses of WTT results. Performance of different HL solutions will be compared and recommendations will be provided.	M13 + 2

Note: In the table above, Mx means T0+ x months.

3. Major Deliverables/ Milestones and schedule (estimate)

*Type: R=Report, D=Data, HW=Hardware

The deliverables and milestones are in accordance with the general work plan of the AIRFRAME ITD (SAT):

Deliverables			
Ref. No.	Title – Description	Type*	Due Date
D.1	Report on Model description, design including structural computations	R	T0 + 4
D.2	Report on the Model Manufacturing and Equipment	R	T0 + 12
D.3	Report on Wind Tunnel Tests comprehensive of Wind tunnel corrections descriptions	R, D	T0 + 14
D.4	Report of Experimental Assessment of Selected HL Concept	R	T0 + 15

Milestones (when appropriate)			
Ref. No.	Title - Description	Type*	Due Date
M.1	Frozen design of Wind Tunnel Model	R	T0 + 4
M.2	Midterm Review Meeting – Tests Programme	R	T0 + 7
M.3	Start of Wind Tunnel Tests	HW	T0 + 10
M.4	Experimental Assessment of Selected HL Concept	R	T0 + 15

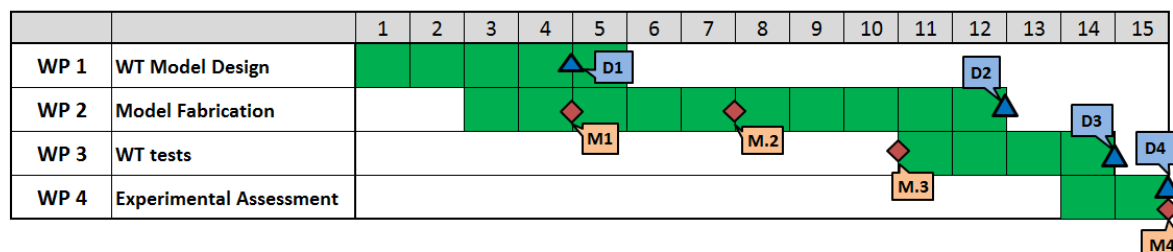

4. Special skills, Capabilities, Certification expected from the Applicant(s)

Special expected skills are:

- Experience in research and development in aerodynamics fields including the expertise in high lift system assessment.
- Experience in wind tunnel model design for pressure measurements.
- Experience in wind tunnel model manufacturing.
- Experience in wind tunnel model instrumentation.
- Experience in wind tunnel tests with additional sources of flow for blowing simulation.
- Experience in wind tunnel test measurement techniques, in particular pressure measurement technique
- Wind tunnel enabling testing of wing segment for Reynolds numbers at least 5.106
- Pressure scanners supporting at least 250 measurements points with sampling frequency at least 300 Hz



- Experience in flow visualization using taps and PIV techniques

5. **Abbreviations**

AIR	Airframe ITD
A/C	Aircraft
CFD	Computational Fluid Dynamic
CfP	Call for Proposal
CLmax	Maximum of lift coefficient
CNC	Computer Numerical Control
HL	High Lift
ITD	Integrated Technology Demonstrator
JTP	Joint Technical Proposal
PIV	Particle Image Velocimetry
R&D	Research and Development
SAT	Small Air Transport
WP	Work Package
WT	Wind Tunnel
WTT	Wind Tunnel Test

VI. JTI-CS2-2018-CFP09-AIR-02-72: MEMS sensors, wireless and innovative measurement systems for validation of HVDC system Structure integration and for new SHMS architectures

Type of action (RIA/IA/CSA):		IA	
Programme Area:		AIR	
(CS2 JTP 2015) WP Ref.:		WP B-3.2	
Indicative Funding Topic Value (in k€):		600	
Topic Leader:	Airbus Defence & Space	Type of Agreement:	Implementation Agreement
Duration of the action (in Months):	24	Indicative Start Date (at the earliest)⁶⁶:	Q3 2019

Topic Identification Code	Title
JTI-CS2-2018-CFP09-AIR-02-72	MEMS sensors, wireless and innovative measurement systems for validation of HVDC system Structure integration and for new SHMS architectures
Short description	
The topic deals with design, development and manufacturing of a complete set up for a MTMPSN that allows the airframe Usage, Events and Damages monitoring for Health Monitoring of the Airframe structure and electrical power networks. It shall provide a common, innovative, data measurement, data analysis, data exploitation environment and requirements for MTMPSN, considering the use of MEMS-based sensors, Energy Harvesting and Wireless technologies to ensure the MTMPSN reliability in aircraft ground and rig test environments.	

Links to the Clean Sky 2 Programme High-level Objectives⁶⁷				
This topic is located in the demonstration area:			Enabling Technologies	
The outcome of the project will mainly contribute to the following conceptual aircraft/air transport type as presented in the scene setter:			Regional Multimission TP, 70 pax	
With expected impacts related to the Programme high-level objectives:				
Reducing CO₂ emissions	Reducing NO_x emissions	Reducing Noise emissions	Improving EU Competitiveness	Improving Mobility
<input type="checkbox"/>	<input type="checkbox"/>	<input type="checkbox"/>	<input checked="" type="checkbox"/>	<input type="checkbox"/>

⁶⁶ The start date corresponds to actual start date with all legal documents in place.

⁶⁷ For further info see Chapter 1 "Introduction to the Programme Scene Setter / Objectives" with key technology themes / demonstration areas. Detailed information available in the CS2 Development Plan accessible via the Clean Sky JU Website and EC Participant Portal.

1. Background

During the last years the technologies involved in the integrity assurance of the Airframe have experienced a great development. They are the so called Airframe Health Monitoring Technologies, including the Structural Health Monitoring development started during CS1.

The concepts of Structural Health Monitoring (Usage, Diagnosis and Prognosis) are fully applicable to other airframe elements such as power quality electrical networks. If it is focused in the Diagnosis Monitoring, in general words, considering it as an event and damage (anomalies) detection strategy it could be applicable for the integrity assurance or control of the structure, and other airframe elements with minimum adaptations in the design.

Currently the Aircraft Maintenance Program is based on A/C certification fixed results and tests. This maintenance program ensures the continued airworthiness of the airframe.

The structure of the aircraft on multi-mission role or performing civil non-conventional operations is very sensitive to the usage. The aim of this topic is to study the feasibility of SHM certification able of modifying the A/C certified maintenance program according to a real operation.

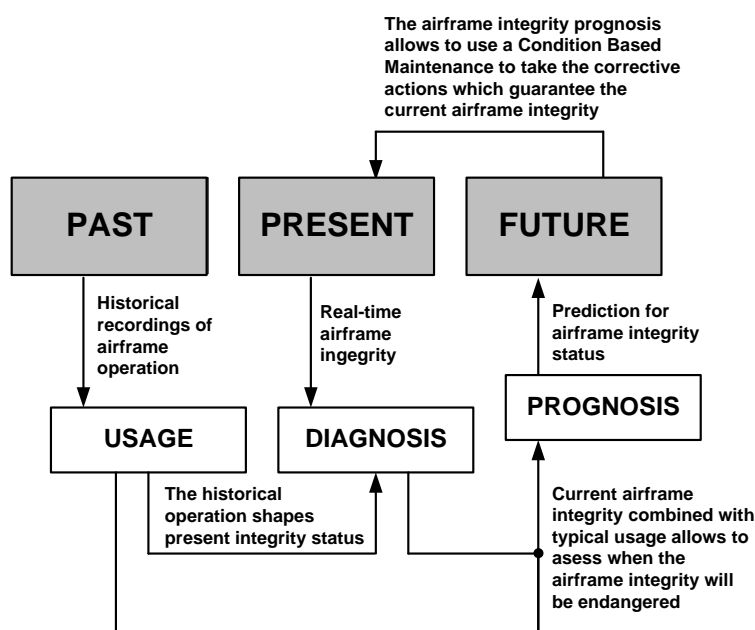

The main advantages of a Condition Based Maintenance are: A/C platform availability figures improvement, maintenance scheduling and cost optimization for A/C platform. All these advantages ensure a cost reduction in the operation of the A/C and also have an important impact on certification principles of the SHM itself and the monitored elements, which is also included as a topic in this CfP. Condition Based Maintenance of use is one of the current trend in the industry 4.0 based on the use of Data Analytics. Analysis of the existing standards documentation up to date from the point of view to be ready for expected certification procedures, applicable to the Health Monitoring concept, is also part of this call.

There is no specific civil regulation (EASA or FAA) for Airframe Health Monitoring but it is expected to appear in the short/medium term. Currently, for structures there is Structural Health Monitoring guidelines for fixed wing civil aircraft from SAE (ARP6461). For another airframe elements there is another SAE initiative called Integrated Vehicle Health Monitoring which includes guidelines.

In the case of the innovative approach presented in this call, the use of an integrated system for both



structural health and power quality monitoring provides the advantage of a reduction in complexity as only one device is installed on-board for both purposes. So it ensures a common framework for Data Analytics and future regulations fulfillment for Health Monitoring. It also simplifies test installation on A/C and ensures having a unique interconnection platform to allow its future use within hybrid / virtual architectures.

2. Scope of work

The main objective of the Multi Type Multi Purpose Sensor Network Quality (MTMPSNQ) validation test environment is to demonstrate the feasibility (and certifiable-readiness) of a common development for structure health monitoring electrical and power quality considering the integration of a unique MTMPSN and equipment for:

- Structural event and damage diagnosis.
- HVDC electrical network diagnosis.

The MTMPSNQ validation test environment, core of the topic, shall be capable of integrate test installations both for structural and electrical power diagnosis in terms of test set up, data acquisition, data recording and data analysis. In addition, the MTMPSNQ shall be capable of executing all test methods and verifying all test pass/fail criteria in an automated way as they are defined on applicable directives. The MTMPSNQ validation test environment shall be designed to cover all test groups and methods of the following directives included in chapter 4 as a reference

The test environment shall compile the following innovative aspects:

- Energy harvesting solutions at MEMs sensors
- Sensors compatibility: strain, acceleration, voltage (HVDC), current and temperature transducers properly conditioned and isolated, and considering whereas applicable innovative solutions MEMs and LiFi and/or Wifi based
- Complex sensors simulation capabilities
- Open related SW development Labview, Matlab and Simulink compatible
- Automation and Data Analytics capabilities

The MTMPSNQ validation test environment shall be used at ground at both FTB#2 demonstrator aircraft and O/G Wing Actuation Rig platforms (with the intention of clearing validation on flight afterwards), respectively, in order to validate the interaction between HVDC electrical networks and their corresponding installation issues at aircraft platform (isolation topics, grounding, 0Volts reference, etc.). For ensuring proper operation at these different environments the following aspects shall be considered:

- Portability
- Able to perform flight tests and ground tests
- Compatible with an existing power supply for voltage profile generation according to power quality directives.
- Acquisition system suitable for SHM implementation and Power Quality tests. COTS approach may be accepted in order to reduce risks and to concentrate on the MEMs sensors approach for MTMPSNQ.
- I/O interface applicable to FTB#2 demonstrator

In addition, the activities asked in this proposal shall be also focused on the exploration of existing standards related to Health Monitoring and how they can be included in a set of fixed requirements to fulfil a future certification.

It includes the compatibility of existing standards for structure, with a future expected certification

means of compliance, trying to minimize the changes of current certification means to future ones. It also includes implicitly the evaluation of typical aircraft maintenance program and its link with the output of a Health Monitoring using the mentioned MTMPSN test environment for structural health monitoring (Usage).

COMPONENT	TECH. CHALLENGE	TECH. DEMONSTRATOR
Innovative MTMPSN	Same framework for structural and power quality monitoring (usage, diagnosis and prognosis)	Portable test environment
Innovative MTMPSN	Integration of MEMS based sensors with energy harvesting capabilities and wireless technologies	Portable test environment
Innovative MTMPSN	Complex sensors simulation framework	Portable test environment
Innovative MTMPSN	Innovative cross standard unitary testing upon different power quality directives applied to power quality monitoring	Portable test environment
Innovative design MTMPSN	Readiness for Health Monitoring process expected requirements	Structural Health Monitoring Process for usage

The Topic should be organized in two technical Work Packages (WPs) devoted to on A/C on-ground and flight test for Structural Health and Electrical Power Quality monitoring:

- WP1: Design, development, manufacturing of test environment and support to testing activities.
- WP2: Define the minimum requirements to be applied to structural health monitoring process to modify the maintenance program.

Tasks		
Ref. No.	Title - Description	Due Date
T1.1	Requirements analysis and trade off	T0 + 3
T1.2	PDR	T0 + 4
T1.3	CDR	T0 + 6
T1.4	Manufacturing and assembly	T0 + 10
T1.5	SW development	T0 + 10
T1.6	ATP	T0 + 11
T1.7	Delivery and training	T0 + 12
T1.8	Support and testing activities	T0 + 24
T2.1	Review of existing documentation about aircraft structure monitoring standards or guidelines and summarize the requirements.	T0+6
T2.2	Interaction of structural health monitoring with aircraft maintenance program and derived requirements to allow this link.	T0+18
T2.3	Expected requirements report for a certifiable Structural Health Monitoring with the capability of maintenance program modification for structure applied to MTMPSN for Structural Usage Monitoring.	T0+24

3. Major Deliverables/ Milestones and schedule (estimate)

*Type: R=Report, D=Data, HW=Hardware, SW=Software

Deliverables			
Ref. No.	Title - Description	Type*	Due Date
D1.1	ATP environment definition	D	T0 + 10
D1.2	ATP environment test results, test environment documentation, list of parts, COTS suppliers, user manual and maintenance manual. PRC documentation, mechanical and electrical drawings	R+D	T0 + 12
D1.3	Test environment	HW	T0 + 12
D1.4	SW code	SW	T0 + 12
D2.1	SHM existing standards exploration report	R	T0+6
D2.2	SHM existing standards adaptation report	R	T0+12
D2.3	SHM needed requirements report	R	T0+18
D2.4	SHM requirements validation report on MTMPSN test environment for Usage Monitoring	R+D	T0+24

Milestones			
Ref. No.	Title - Description	Type*	Due Date
M1	MTMPSN test environment KOM	R+D	T0+1
M2	MTMPSN test environment PDR	R+D	T0 + 4
M3	MTMPSN test environment CDR and Delivery of D2.1 report	R+D	T0 + 6
M4	MTMPSN test environment delivery and D2.2 report	HW	T0 + 12
M5	Delivery of D2.3 report	R	T0 + 18
M6	MTMPSN test environment FCR and Delivery of D2.4 report and results data	R+D	T0 + 24

4. Special skills, Capabilities, Certification expected from the Applicant(s)

- Solid knowledge and experience in the following directives/guidance: DEF-STAN 00-970 Part1 Sect3, SAE-ARP-6461, MIL-STD-704, AMD-24, DO-160, ABD100.1.8, DO-178C, DO-254.
- Solid knowledge and capabilities for designing and manufacturing mechanical, electrical and electronic test environments.
- Deep knowledge in transducers/sensors development including MEMS-based, energy harvesting and wireless technologies.
- Solid knowledge of AutoCAD mechanical/electrical design.
- Solid knowledge of control and acquisition systems, included SW open code development related based on National Instruments (LabVIEW/Veristand & Teststand, Matlab/Simulink).
- Engineering software and licenses for Computer Aided Design (CAD), and appropriate high performance computing facilities.
- Engineering software and licenses for LabVIEW/Veristand & Teststand, Matlab/Simulink, and appropriate high performance computing facilities.
- Capability of specifying, performing and managing, in collaboration with the Leader, the following:
 - Analysis of the mechanical, electrical and control/acquisition requirements.
 - Structural Health Monitoring (event and damage diagnosis) data acquisition



- Power supply control/acquisition system definition.
- Trade-off for selection of the industrial elements to be included in the test environment.
- Mechanical and Electrical AutoCAD design for environment manufacturing.
- SW specification for control, acquisition, analysis and test report generation system.
- Acceptance Test Procedure Definition.
- Quality System international standards (i.e. EN 9100:2009/ ISO 9001:2008/ ISO 14001:2004).
- CE marking.
- Experience in Structural Health Monitoring (for structure, systems and power plant).
- Experience in aircraft certification standards (structure, systems and power plant).
- Experience in aircraft structural tests.
- Experience in aircraft systems tests.
- Experience in structure/systems reliability assessment.

5. Abbreviations

MTMPSN	Multi Type Multi Purpose Sensor Network
A/C	Aircraft
AC	Alternate Current
ATP	Acceptance Test Procedure
CfP	Call for Proposal
CAD	Computer Aided Design
CDR	Critical Design Review
CIPS	Customer Inspection at Purchaser Site
CISS	Customer Inspection at Supplier Site
COTS	Commercial off-the-shelf
EIS	Entry Into Service
EMA	Electro-Mechanical Actuator
FCR	Final Closure Review
KOM	Kick-Off Meeting
HM	Health Monitoring
HVDC	High Voltage Direct Current
HVPQ	High Voltage Power Quality
HW	Hardware
O/G	On Ground
MEMS	MicroElectroMechanical Systems
PC	Personal Computer
PDR	Preliminary Design Review
SW	Software
SHM	Structural Health Monitoring
UUT	Unit Under Test
WP	Work Package

VII. JTI-CS2-2018-CFP09-AIR-02-73: Material modelling platform for generation of thermoplastic material allowable

Type of action (RIA/IA/CSA):		RIA	
Programme Area:		AIR	
(CS2 JTP 2015) WP Ref.:		WP B-3.3.2	
Indicative Funding Topic Value (in k€):		1250	
Topic Leader:	Airbus	Type of Agreement:	Implementation Agreement
Duration of the action (in Months):	36	Indicative Start Date (at the earliest)⁶⁸:	Q3 2019

Topic Identification Code	Title
JTI-CS2-2018-CFP09-AIR-02-73	Material modelling platform for generation of thermoplastic material allowable
Short description	
The project will target the development of a material modelling platform for thermoplastic material. Numerical model of thermoplastic coupons necessary for material certification will be automatically generated in order to provide robust design allowable. Uncertainty Quantification and Management method will also be used to provide numerical error associated to every generated virtual allowable in order to quantify the effect on model input parameter variability.	

Links to the Clean Sky 2 Programme High-level Objectives⁶⁹				
This topic is located in the demonstration area:			Advanced Manufacturing	
The outcome of the project will mainly contribute to the following conceptual aircraft/air transport type as presented in the scene setter:			Advanced Long Range	
With expected impacts related to the Programme high-level objectives:				
Reducing CO₂ emissions	Reducing NO_x emissions	Reducing Noise emissions	Improving EU Competitiveness	Improving Mobility
<input checked="" type="checkbox"/>	<input type="checkbox"/>	<input type="checkbox"/>	<input checked="" type="checkbox"/>	<input type="checkbox"/>

⁶⁸ The start date corresponds to actual start date with all legal documents in place.

⁶⁹ For further info see Chapter 1 "Introduction to the Programme Scene Setter / Objectives" with key technology themes / demonstration areas. Detailed information available in the CS2 Development Plan accessible via the Clean Sky JU Website and EC Participant Portal.

1. Background

The current development proposed in this Call will be done in the frame of Clean Sky 2 aiming at maturing and validating disruptive technologies for the next generation Large Passenger Aircraft (LPA) through large scale integrated demonstrators.

This call is related to activities running under the ITD Airframe WP B-3.3 oriented towards highly integrated cockpit but more specifically towards “LPA Cockpit innovative structural components” WP B-3.3.2 as presented in the work breakdown structure below.

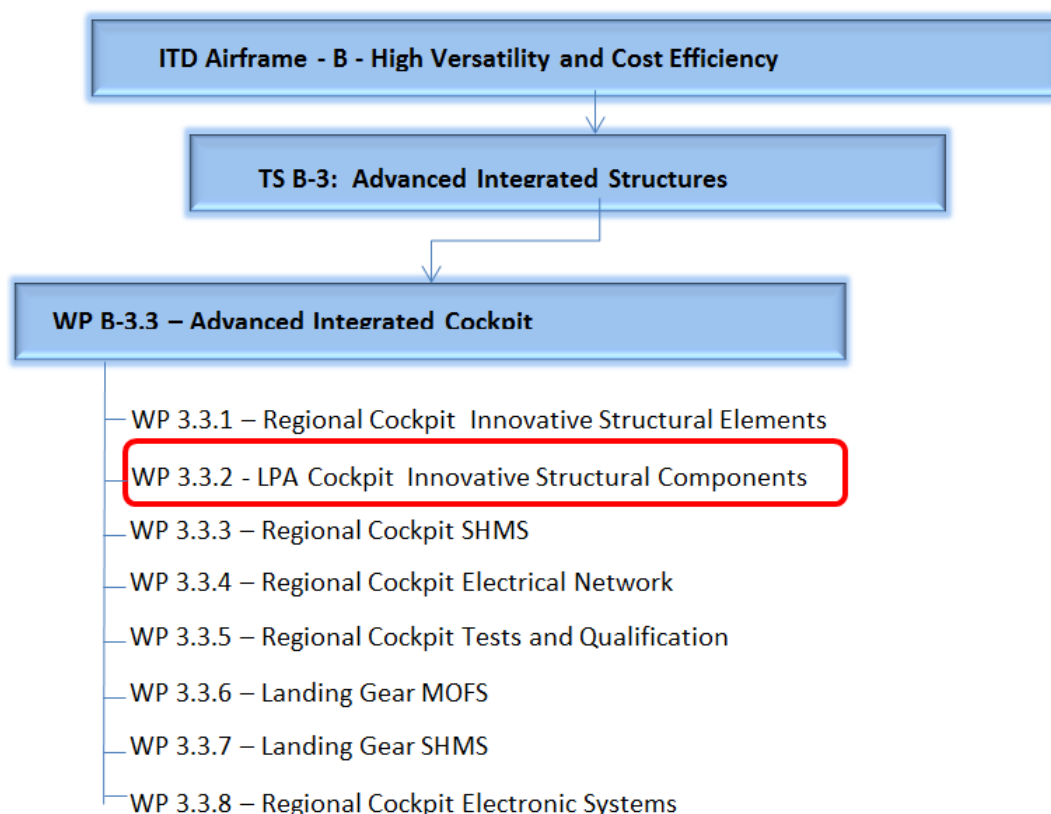

Figure 1 – WBS of ITD AIRFRAME – WP B-3.3: High Versatile High Versatility and Cost Efficiency

The current CfP outcome will be an input to the LPA technology demonstrators developed within LPA IADP Platform 2 “Innovative Physical Integration Cabin – System – Structure”. The Topic Manager will define the applicable context related to the demonstrator design, manufacturing and testing for proof of concept.

Aircraft Program Development Plan (PDP) are increasingly challenged in order to reach an optimum balance between cost and time of entry into market. In order to reduce cost and lead-time, next PDP has to reinforce its digitalisation, for instance, through improved Product Life Cycle Management, Co-Design or Model Based System Engineering. The latter development axis encompasses various topics, such as multi-disciplinary, optimisation, aerodynamics or structure analysis, which will provide next generation numerical capabilities enabling to increase and reach earlier design maturity and robustness; but also optimise recurring and non-recurring cost induced by physical testing, for instance.

A first high level objective to which this current CfP will contribute is to support aircraft design but also



reduce or even replace physical structural testing by numerical analysis, namely Predictive Virtual Testing. A key requirement is that numerical analysis must predict all damages and failures modes at both material and component levels.

This CfP also contributes to a second high level objective, which is to accelerate the trend towards simulation based Means of Compliance (MoC) with regards to aircraft certification and to promote numerical analysis as a secured certification MoC acknowledged and validated by the civilian Aviation Authorities.

More specifically, this CfP will enable to provide virtual design allowable in early phase of the design and reduce dramatically lead time involved in physical test campaign from material screening to certification. This new numerical platform will also reduce the size of the test pyramid for material certification.

2. Scope of work

The topic addresses the development of a material modelling platform for thermoplastic material used for Multi-functional Thermoplastic Fuselage. Numerical model of thermoplastic coupons, such as Open Hole Tension, necessary for material certification, will be automatically generated in order to provide robust design allowable. Uncertainty Quantification and Management method will also be used to quantify the effect of model input parameter variability (e.g. ply stiffness, hole diameter tolerance, etc.). The applicant shall perform and deliver a state of the art of all damage and failure material models available in literature for thermoplastics. An assessment will be conducted in order to evaluate if existing models can readily be used in the project or models developments are required.

Tasks		
Ref. No.	Title – Description	Due Date
1	Management and coordination	T0 + 36
2	Novel thermoplastic material damage and failure model	T0 + 18
3	Thermoplastic specimen manufacturing	T0 + 6
4	Test campaign for design allowable	TO + 16
5	Parametric coupon model creation for virtual design allowable automated generation	TO + 24
6	Uncertainty Quantification and Management for virtual design allowable	T0 + 24
7	Platform for generation thermoplastic material virtual allowable	T0 + 36

Task1: Management and coordination

The applicant will manage and coordinate the project and ensure due course of the project by respecting deliverables and milestones. Bi-weekly reporting via emails, WebEx or meetings will be organised with the Topic Manager in order to achieve progressive internal dissemination. The milestone reviews will be every six months to close and review tasks; those will be either via WebEx or face-to-face.

Task2: Novel thermoplastic material damage and failure model

An innovative material damage and failure model shall be developed to capture all damage and failure modes observed in test. For this, an exhaustive test campaign shall be undertaken to characterise selected thermoplastic material used for the multifunctional fuselage demonstrator. This characterisation shall address static and dynamic loading rates.

Below is a non-exhaustive list of coupon test to be conducted to characterise ply and interface,

- Tensile Fibre failure
- Compressive fibre failure
- Matrix tensile failure
- Matrix compressive failure
- Shear tensile
- Double End Notch (intra-laminar fracture toughness)
- Double Cantilever Beam
- End-notch-Flexure
- Mix-Mode-Bending
- Inter-laminar shear strength
- In-situ effects

The final definition of the test matrix shall define a minimum number of specimens to ensure a robust statistical distribution.

Finally, this material damage and failure model shall be validated by correlation between test and simulation results.

Task3: Thermoplastic specimen manufacturing

The applicant(s) shall manufacture specimen in-house using raw material acquire from Topic Manager recommended manufacturer. The applicant(s) shall show proof of record for thermoplastic material manufacturing up to industrial standard. A dedicated budget from overall project's budget shall be used for material acquisition.

Task4: Test campaign for design allowable

An exhaustive test campaign will be conducted to produce design allowable (Conservative and Mean values), which will be used as reference to validate virtual design allowable generated by models.

Following coupons will be investigated,

- Plain Tension under static and dynamic conditions
- Plain Compression under static and dynamic conditions
- Open Hole Tension
- Open Hole Compression
- Filled Hole Tension
- Filled Hole Compression
- Compression After Transverse Impact
- Compression After Edge Impact
- Bearing
- Unfolding / 4 points bending

The final definition of the test matrix shall define a minimum number of specimens to ensure a robust statistical distribution.

Task5: Parametric coupon models creation for virtual design allowable generation

Models of coupons tested in task 4 shall be created integrating modelling methodologies developed in task 2. In order to generate virtual design allowable, models shall follow plan of experiments defined in task 6. For instance, material properties or tolerance uncertainties will be investigated to provide the normal strength distribution of an open hole coupon.

Task6: Uncertainty Quantification and Management for virtual design allowable

A virtual plan of experiment shall be defined for every coupon investigated. Uncertainties inherent to

material, coupon geometry or boundary conditions shall be identified and quantified in order to provide normal coupon strength from which virtual allowable will be calculated. This task shall be run in parallel to task 5 in which parametric models will be created (e.g. hole diameter variation).

Task7: Platform generation thermoplastic material virtual allowable

A platform with a graphic user interface shall be created to generate parametric coupon models. The user will be able to enter specimen geometry, lay-up and intervals for all uncertainties. The platform will use models developed in task 5 to build the user's coupon and run its pre-defined plan of experiment. The platform will provide most importantly the mean and B-values but also advanced damage/failure criteria for complementing user understanding of coupon's mechanical behaviour.

This platform should first be developed for user with a limited background in composite material modelling; however it will offer an 'expert mode', which will be used only for improving numerical methodologies or plan of experiments.

3. Major Deliverables/ Milestones and schedule (estimate)

*Type: R=Report, D=Data, HW=Hardware

Deliverables			
Ref. No.	Title – Description	Type*	Due Date
1	Literature survey on damage and failure models for thermoplastic materials	R	T0+1
2	Thermoplastic material properties, damage and failure modes identification through advanced testing	R, D	T0+12
3	Numerical methods for modelling thermoplastics materials physical behaviour - Validation against elementary coupon test	R, D	T0+18
4	Design allowable generation issued from physical testing – detailed description of damage and failure modes observed for every coupon configuration	R, D	T0+24
5	Virtual Design allowable generation and validation upon physical testing	R, D	T0+30
6	Platform with GUI running with Abaqus solver	R, D	T0+32
7	Final Report – Summarising Findings of complete project	R, D	T0+36

Milestones (when appropriate)			
Ref. No.	Title - Description	Type*	Due Date
1	Review and closure of task 3 and work plan presentation for all other tasks	R	T0 + 6
2	Review and update on all tasks	R + D	T0 + 12
3	Review and closure of task 2, 4 and update on all other tasks	R + D	T0 + 18
4	Review and closure of task 5, 6 and update on all other task	R + D	T0 + 24
5	Review of virtual design allowable platform – live demonstration	R + D	T0 + 30
6	Project closure	R + D	T0 + 36



4. Special skills, Capabilities, Certification expected from the Applicant(s)

Essential skills:

- Applicant(s) will need to be specialist(s) in advanced structural numerical analysis with advanced skills in composite failure modelling.
- Applicant(s) shall have experience with probabilistic methods (e.g. Monte Carlo, Latin Hypercube, Mean Value Method, 1st and 2nd order Reliability Methods, etc.).
- Applicant(s) shall have extended experience with commercial finite element code Abaqus.
- Demonstration of track-record in having material models selected to be implemented in commercial Finite Element codes.
- Demonstration of track-record in defining best-practice guidelines for the use of analysis methods at industry level.
- Demonstration of experience in high strain rate testing of polymer composites using Hopkinson Bars.
- Demonstration of track-record in manufacturing thermoplastic composites.
- Nadcap and ISO17025 accredited lab to perform experimental characterization of non-metallic materials.

Essential equipment:

- Enough computational resources estimated by Topic Manager of at least 500 CPU and at least 300 tokens to run parallel simulations feeding plans of experiment
- Equipment for monitoring of damage onset and evolution (X-ray tomography, C-scan and Digital Image Correlation).
- Manufacturing capabilities to produce the specimens.

VIII. **JTI-CS2-2018-CFP09-AIR-02-74: Development of a multipurpose test rig and validation of an innovative rotorcraft vertical tail**

Type of action (RIA/IA/CSA):		IA	
Programme Area:		AIR	
(CS2 JTP 2015) WP Ref.:		WP B-4.2.3	
Indicative Funding Topic Value (in k€):		700	
Topic Leader:	Fokker Aerostructure	Type of Agreement:	Implementation Agreement
Duration of the action (in Months):	30	Indicative Start Date (at the earliest)⁷⁰:	Q3 2019

Topic Identification Code	Title
JTI-CS2-2018-CFP09-AIR-02-74	Development of a multipurpose test rig and validation of an innovative rotorcraft vertical tail
Short description	
In line with the Clean Sky 2 objectives, the main objective of this call is to contribute to the reduction of fuel consumption and CO ₂ emissions by lowering the structural weight of a rotorcraft tail through application of thermoplastics. The applicant will design and manufacture a test rig and a load application system, which simulates critical flight condition. Furthermore, the applicant will also execute the tests, including all test preparations such as strain and displacement measurement equipment and evaluation of the test data.	

Links to the Clean Sky 2 Programme High-level Objectives⁷¹				
This topic is located in the demonstration area:			Next-Generation Civil Tiltrotor	
The outcome of the project will mainly contribute to the following conceptual aircraft/air transport type as presented in the scene setter:			Next Generation Tiltrotor	
With expected impacts related to the Programme high-level objectives:				
Reducing CO₂ emissions	Reducing NO_x emissions	Reducing Noise emissions	Improving EU Competitiveness	Improving Mobility
<input checked="" type="checkbox"/>	<input type="checkbox"/>	<input type="checkbox"/>	<input type="checkbox"/>	<input checked="" type="checkbox"/>

⁷⁰ The start date corresponds to actual start date with all legal documents in place.

⁷¹ For further info see Chapter 1 "Introduction to the Programme Scene Setter / Objectives" with key technology themes / demonstration areas. Detailed information available in the CS2 Development Plan accessible via the Clean Sky JU Website and EC Participant Portal.

1. Background

One of the key objectives of the Clean Sky 2 programme is to minimize the impact of aviation on the environment through key innovation. This could be achieved by lowering the structural weight through the application of novel composite materials in a Technology Demonstrator in order to reduce the fuel consumption and CO₂ emissions of the aircraft.

A goal associated to the flying Technology Demonstrator under WP B-4.2: "Pressurized Fuselage for Fast Rotorcraft", is to support activities towards a "Permit to Fly" for test flights. One approach is to supply satisfactory evidence to the airworthiness authorities, to ensure safe and reliable operation during the test phase of the aircraft. The typical sub-scale tests currently envisioned are:

- Spar to skin joint test
- A full scale component test including Fin to Aft body attachment or equivalent test

Using the multipurpose test rig, the tests will be used to validate specific key design features of the vertical tail. They allow for validation of the used finite element models and also build towards innovative joint concepts such as a hybrid spar to skin joint. Hybrid in this context refers to a joint, which is both bonded and fastened. The insight gained with these test will allow for possible design optimisations in terms of weight and performance. Specific conservative approaches may be refined to facilitate this.

Under WP B-4.2, activities to be performed by Topic Manager deal with the development of concepts for the tail of the Technology Demonstrator and the development of innovative technology to be included in the Technology Demonstrator including thermoplastic components.

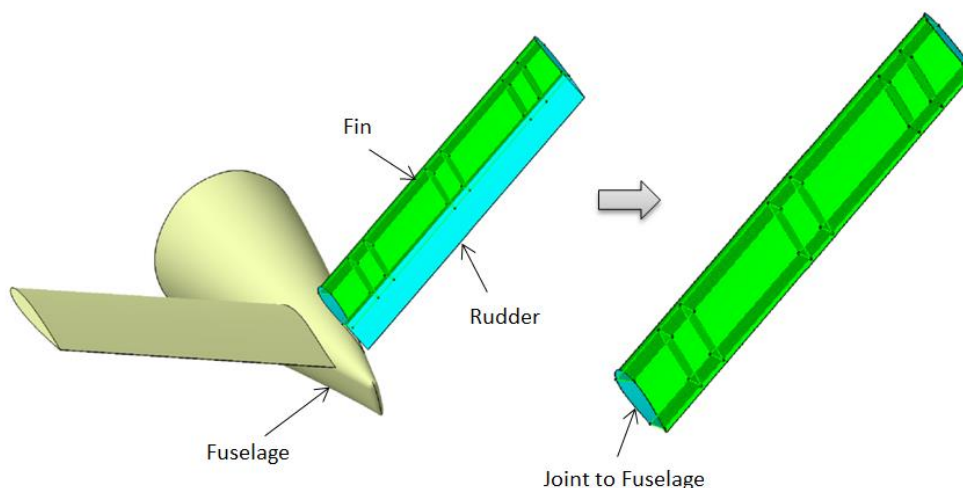

Figure 1 – Fin as part of the Technology Demonstrator Tail

The work to be executed by the applicant is linked to Topic Manager activities which supports the certification of the flying rotorcraft tail. The tail will contain a combination of new technology and new type of thermoplastic material. The tests will only be executed for the fixed part of the tail.



2. Scope of work

The applicant(s) will provide an innovative experimental set-up for the investigation of strength and stiffness of new technology parts in a representative environment.

The representative environment is partly a fin with the innovative parts incorporated; the fin will be supplied to the applicant by the Topic Manager. However, part of the environment is the joint of the fin to the fuselage. Representative stiffness of the fuselage joints is required to obtain accurate internal loading in the fin. Instead of having part of the fuselage available, the applicant shall design a test rig such that a variable stiffness can be obtained for a range of possible (“fuselage”) joints taking into account a range of designs as well.

The baseline design will be a fin with indicatively a span of 3m and a chord of 0.6m. A number of discrete load introduction points will be present at the trailing edge.

The applicant will be responsible for the design and manufacturing of the test rig, equipping of measurement equipment and test execution of the test articles, processing and evaluation of the obtained test data, and validation of the finite element models. In addition, an advanced interface disbond analysis and test is part of the activity. In the evaluation of the tests, the applicant will support the activity towards achieving a ‘Permit to Fly’. The following tasks are identified:

Tasks		
Ref. No.	Title - Description	Due Date (months)
T1	Management	T0 + 30
T2	Design and manufacture of the multipurpose test rig	T0 + 10
T3	Test execution	T0 + 15
T4	Numerical validation & correlation	T0 + 18
T5	Interface disbond propagation simulation test and analysis of a spar to skin joint	T0 + 30

Task 1: Management

This task is devoted to the management of the project in order to ensure that all obligations are fully respected, from contractual, financial and technical progress point of views. Taking into account the strong interactions between activities performed by the Topic Manager and the Applicant(s), the present task will assure communication and reporting between the Applicant(s), the Topic Manager and CSJU.

Task 2: Design and manufacture of the multipurpose Test Rig

The applicant(s) will be supported by the Topic Manager who will be providing detailed fin information (geometry, CAD files of interfaces, loads) and joint stiffness requirements for the design of the multipurpose test rig. The applicant is responsible for the development of a test rig and load application mechanism. The applicant is encouraged to propose innovative test rig concepts, especially in the field of load applications.

The applicant will be responsible for the manufacturing of the various components of the test rig. Also included in the activity is the supply of sensors and actuators components (including electronic devices). Regarding the instrumentation, the applicant(s) will equip the fin with strain gauges (at least 100 channels) and LVDT’s (at least 10). Special attention shall be given to the verification of the joint stiffness.



Task 3: Test execution

The test execution task deals with development of test plans, installing all measurement equipment and to perform all structural tests. Static structural tests shall be up to ultimate load (not Failure) for a number of representative load cases (at least 5). The Topic Manager will supply the essential load data necessary to execute the tests and test specimen. The Topic Manager will also witness the tests and support the applicant in case of unexpected events.

Task 4: Numerical validation & correlation

The applicant will create test evaluation reports in which the measured results (strains, displacements, loading) are compared to predictions. The prediction will be obtained from a detailed FEM and needs to be completed in advance of the test execution phase. The fin FEM will be provided to the applicant(s), but the applicant(s) is/are responsible for the proper application of test loading and fuselage joint as well as adding dummy elements at locations where strain gauges are applied. These “dummy” elements can be used to extract the strains for direct comparison to the measurements.

Task 5: Interface disbond propagation analysis and test

There are several options to design a spar to skin joint in a tail like for instance fastened, bonded, welded and combined joints. In the latter options, either bonding or welding is combined with fastening where the fasteners can act as a crack arresting mechanism. The specific benefits are a reduced fastener count, which results in a lighter design.

Using the multipurpose test rig, the applicant shall conduct a sub-scale test on a spar to skin joint comprised of a minimum number of fasteners and either bonding or welding. Propagation of interface disbonds is the failure mechanism that needs to be tested and in consultation with the Topic Manager, these tests may involve both static and dynamic tests. Advanced simulation techniques such as virtual testing may be applied to analyse the crack propagation. The applicant is also required to develop and conduct characterisation tests needed to provide input to the material models for such an analysis.

3. Major Deliverables/ Milestones and schedule (estimate)

*Type: R=Report, D=Data, HW=Hardware

Major Deliverables and Milestones are summarized in the following tables:

Deliverables			
Ref. No.	Title - Description	Type*	Due Date (months)
D1	Requirements definition document	R	T0 + 01
D2	Test plan including estimate of theoretical strains/load response	R	T0 + 06
D3	Test Rig delivery	HW	T0 + 10
D4	Full scale static Test Data	D	T0 + 15
D5	Numerical validation and correlation test including data files	R	T0 + 17
D6	Crack propagation analysis report and analysis files	R	T0 + 28
D7	Spar – Skin subscale test report including test data	R	T0 + 28
D8	Final synthesis report	R	T0 + 30

Milestones (when appropriate)			
Ref. No.	Title - Description	Type*	Due Date (months)
M1	Kick-Off Meeting	R	T0
M2	Test Rig PDR	R	T0 + 02
M3	Test Rig CDR	R	T0 + 06
M4	Test Readiness Review (full scale test)	R	T0 + 12
M5	Test Readiness review (disbond test)	R	T0 + 18
M6	Closure Meeting	R	T0 + 29

The GANNT chart below provides an indicative schedule for the deliverables and milestones, as well as tasks.

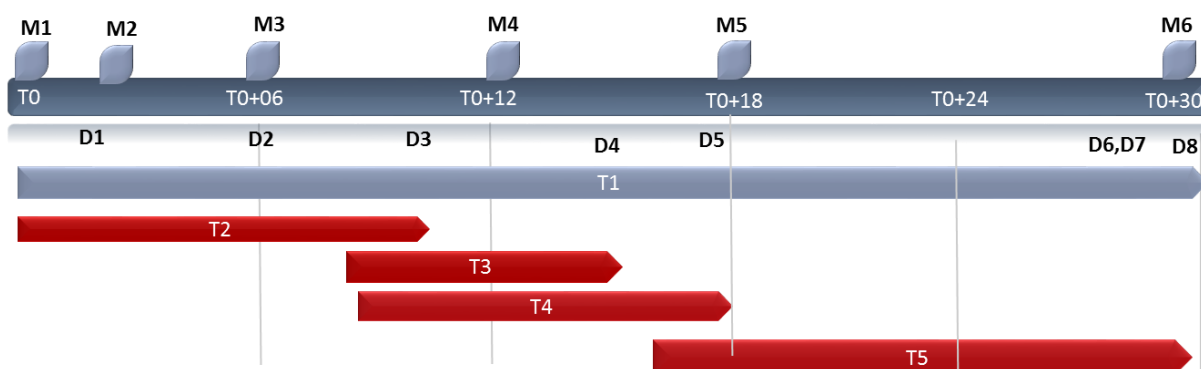

4. Special skills, Capabilities, Certification expected from the applicant(s)

Special skills

- The applicant shall be able to demonstrate sound technical knowledge in the field of asked contributions
- The applicant shall provide evidence to be able to cope with the required high level of adequate resources in qualified personnel, required tools and equipment.
- The applicant shall have a background in the design/sizing and the manufacturing of test rigs for structural tests.
- The applicant shall have experience with providing convincing evidence to airworthiness organizations.
- The applicant shall have demonstrated experience with and access to of CAD software CATIA V5® (or a compatible software) and FEM software NASTRAN to ensure data exchanges with the Topic Manager (inputs and deliverables).
- The applicant will have a demonstrated experience in advanced simulations and testing for interface disbond analysis.

Capabilities

- The applicant should have work-shop facilities in line with the proposed deliverables and associated activities or, if such equipment is not available, have existing relation with institutions or companies that accommodate such equipment.



5. Abbreviations

CAD	Computer Aided Design
CDR	Critical Design Review
CSJU	Clean Sky Joint Undertaking
FEM	Finite Element Model
LVDT	Linear Variable Differential Transformer
PDR	Preliminary Design Review
WP	Work Package

IX. JTI-CS2-2018-CFP09-AIR-02-75: Design Against Distortion: Part distortion prediction, design for minimized distortion, additive manufactured polymer aerospace parts

Type of action (RIA/IA/CSA):		RIA	
Programme Area:		AIR	
(CS2 JTP 2015) WP Ref.:		WP B-4.3.5	
Indicative Funding Topic Value (in k€):		750	
Topic Leader:	Airbus	Type of Agreement:	Implementation Agreement
Duration of the action (in Months):	36	Indicative Start Date (at the earliest)⁷²:	Q3 2019

Topic Identification Code	Title
JTI-CS2-2018-CFP09-AIR-02-75	Design Against Distortion: Part distortion prediction, design for minimized distortion, additive manufactured polymer aerospace parts

Short description
 The aim of this topic is to develop rapid methods to predict material degradation, crystallinity and distortion of additive manufactured PEKK or PEEK parts, with or without fibre reinforcement, as well as to develop methods and tools for topology and shape optimization accounting for distortion.

Links to the Clean Sky 2 Programme High-level Objectives ⁷³				
This topic is located in the demonstration area:		Advanced Manufacturing		
The outcome of the project will mainly contribute to the following conceptual aircraft/air transport type as presented in the scene setter:		Advanced Long Range		
With expected impacts related to the Programme high-level objectives:				
Reducing CO ₂ emissions	Reducing NO _x emissions	Reducing Noise emissions	Improving EU Competitiveness	Improving Mobility
<input checked="" type="checkbox"/>	<input type="checkbox"/>	<input type="checkbox"/>	<input checked="" type="checkbox"/>	<input type="checkbox"/>

⁷² The start date corresponds to actual start date with all legal documents in place.

⁷³ For further info see Chapter 1 “Introduction to the Programme Scene Setter / Objectives” with key technology themes / demonstration areas. Detailed information available in the CS2 Development Plan accessible via the Clean Sky JU Website and EC Participant Portal.

1. Background

Into the ITD Airframe part B, this CFP is linked to WP B-4.3 oriented to more affordable composite fuselage and specifically to WP B-4.3.5 on design against distortion as represented by the workbreakdown structure hereunder.

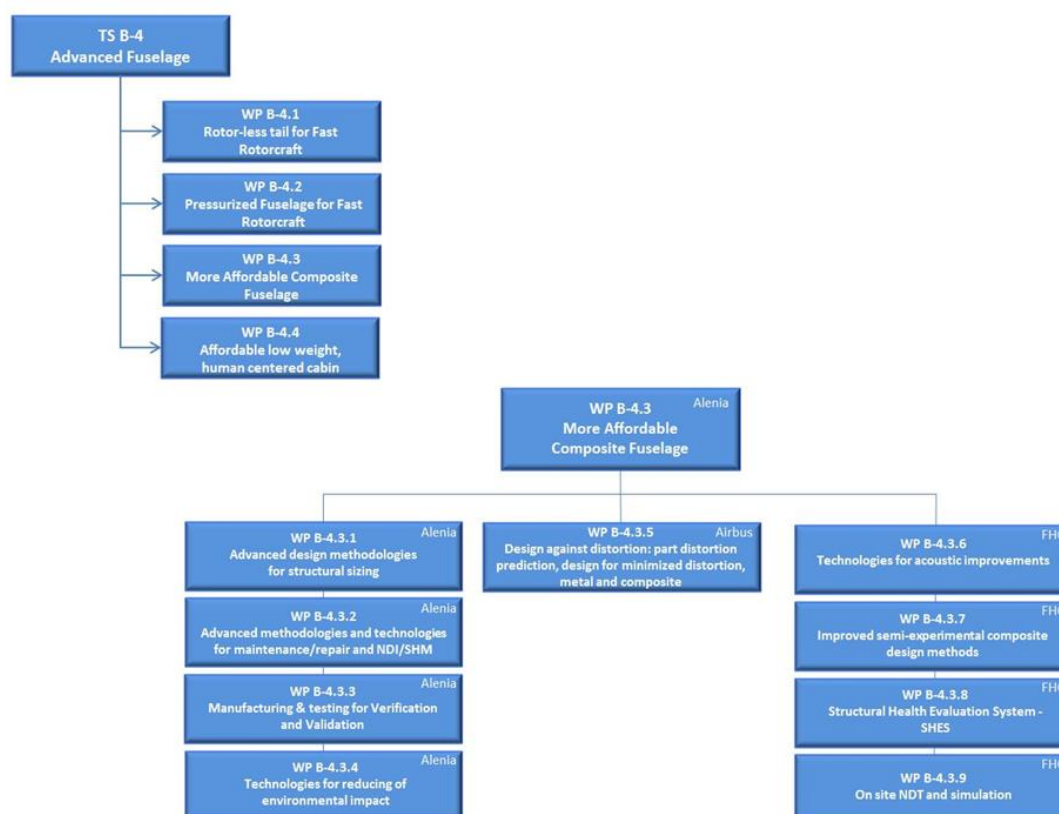

Distortion of aerospace parts is a significant burden on the European aerospace industry, in terms of recurring cost, and in terms of waste production / avoidable impact on the environment. Numerical modelling allows to foresee distortion issues and take corrective measures. These corrective measures are often not taken until a design is already in production. The number of “adjustable variables” is reduced at that stage. The Design Against Distortion Work-Package (WP) aims at developing a means to take corrective action already during part design. In its most innovative form, this means having shape- and lay-up optimisation tools that account not only for the usual design criteria (buckling resistance, mechanical performance in general), but also for the risk of part distortion, and provide the basis for part designs that are more robust against distortion. “Robustness” in this context can mean two things:

- Distorting very little;
- Distorting always in the same, predictable way – irrespective of possible variations in material and processing.

The Work Breakdown Structure for the WP is given in the below figure **Error! Reference source not found.**:

- Top-left, in blue: the topic manager will contribute relevant uses cases, in collaboration with the Clean Sky 2 Demonstration Platform;

- Top-centre, in blue: within the scope of this Call, partners will make distortion predictions and devise ways to exploit these in design;
- Top-right, in blue: towards the end of the work, the topic manager will demonstrate the new technology on the use cases – with support from the partners;
- Second and third levels, in grey: supporting this high-level work-breakdown, a number of subordinate tasks will have to be carried out:
 - To predict distortion accurately and sufficiently rapidly for integration into optimisation loops, the State of the Art in distortion prediction must be improved;
 - These new models will have to be validated, and for this, validation coupons must be manufactured;
 - To exploit the distortion predictions in early design phases, topology and shape optimisation methods must be developed that can integrate above predictions;
 - Because distortion predictions can be time-consuming, it will be necessary to investigate the best way to use them in design optimisation: running in every loop, running less frequently etc.

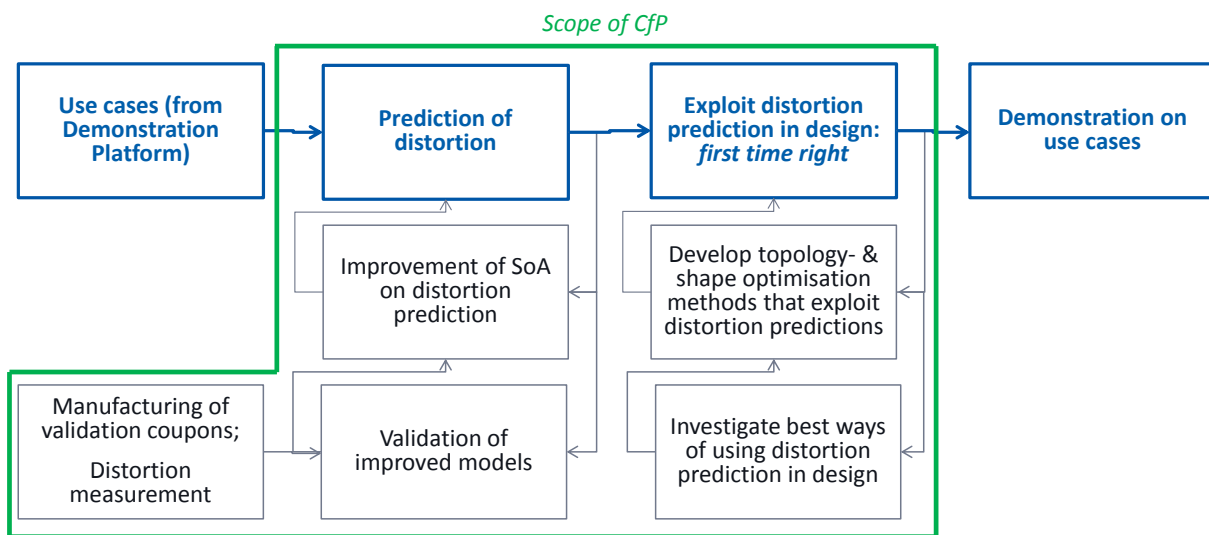

Design against Distortion WP Work-Breakdown Structure

2. Scope of work

To perform the tasks related to this CfP (as detailed in the table below), it will be necessary to develop sufficiently capable residual stress and distortion prediction methods, for the process of polymer additive manufacturing (with- or without fibre reinforcement). These must be validated against experiments on coupons. The coupons must be manufactured and their distortion measured accurately. Several additive process for the manufacture of thermoplastic parts are now used in the aerospace industry. This call will focus on Fused Filament Fabrication, with or without fibre reinforcement, and the new powder-bed type process ThermoMELT. The polymers of interest in this call are members of the PAEK-family.

Distortion during and after the process is mainly due to differential thermal shrinkage caused by strong temperature gradients, as well as possible phase transformation shrinkage or expansion. (Long-) fibre reinforced polymers in theory allow extensive design freedom, however, thermal shrinkage mismatch between polymer and carbon fibre can lead to residual stress and distortion. Various research projects

have already resulted in models to simulate the process and predict the residual stress and distortion. For metal additive manufacturing, it has even proven possible to predict thermal residual stress and distortion in a simplified, rapid way, using the inherent strain method.

Given the above, the following tasks are:

Tasks		
Ref. No.	Title - Description	Due Date
Task 1	Develop and validate a high-fidelity reference process simulation method for Fused Filament Fabrication and ThermoMELT, for PAEK. It may be necessary to perform or subcontract material characterisations, if data are not available in literature. Implement either in a widely used commercial software (e.g. CATIAv5; Abaqus) or an open source alternative (e.g. FreeCAD; CalculiX). Validate model by comparing to experimental measurements. Experiments to be designed using simulation. For Fused Filament Fabrication, validation coupons to be manufactured by the applicant. For ThermoMELT, validation coupons / small parts will be manufactured by the topic manager (i.e. Airbus Operations), but distortion measurements to be performed by the applicant.	T0 + 20
Task 2	Develop and validate a lower-fidelity, rapid process simulation method for above process-material combinations, in view of an integration of the residual stress and distortion prediction into a topology-, shape- and/or local fibre reinforcement (short or long fibres). Implement either in a widely used commercial software (e.g. CATIAv5; Abaqus) or an open source alternative (e.g. FreeCAD; CalculiX)	T0 + 20
Task 3	Develop an optimisation method for topology-, shape- and/or local fibre reinforcement (short or long fibres), that can account for the risk / magnitude of part distortion, using the rapid method developed earlier. Implement preferably in an open source code (e.g. Fortran; C; Python; FreeCAD; CalculiX; ...) enabling tools for 3D part design with computational speed and efficiency which allows for real industrial applications.	T0 + 30
Task 4	Together with the topic manager, apply the implementation to at least one aerospace use-case (a topology-optimised, polymer additive manufacturing part of small size e.g. 250 x 250 x 250mm).	T0 + 36

3. Major Deliverables/ Milestones and schedule (estimate)

*Type: R=Report, D=Data, HW=Hardware

Deliverables			
Ref. No.	Title – Description	Type*	Due Date
D1	High-fidelity reference model for Fused Filament Fabrication	R	T0+18
D2	High-fidelity reference model for ThermoMELT	R	T0+18
D3	Low-fidelity rapid model for Fused Filament Fabrication	R	T0+21
D4	Low-fidelity rapid model for ThermoMELT	R	T0+21
D5	Fused Filament Fabrication validation coupons + distortion measurements thereof	R/D	T0+21
D6	Distortion measurements ThermoMELT validation coupons as	R	T0+21

Deliverables			
Ref. No.	Title – Description	Type*	Due Date
	manufactured by topic manager		
D6	Prototype topology optimisation code capable of accounting for risk of part distortion, as predicted by above models	R	T0+27
D7	Prototype topopt for part distortion and uncertainty	R	T0+36

Milestones (when appropriate)			
Ref. No.	Title – Description	Type*	Due Date
M1	Fused Filament Fabrication distortion prediction. Technology review on approach.	R	T0+12
M2	ThermoMELT distortion prediction. Technology review on approach.	R	T0+12
M3	Fused Filament Fabrication distortion prediction. Model validation review.	R	T0+21
M4	ThermoMELT distortion prediction. Model validation review.	R	T0+21
M5	Demonstration of the prototype of topology optimisation code capable of accounting for risk of part distortion.	R	T0+36

4. Special skills, Capabilities, Certification expected from the Applicant(s)

- Experience with non-linear simulation of polymer transformation processes, such as moulding, welding, selective laser melting: coupled thermal-chemical-mechanical analysis.
- Fused Filament Fabrication machine, capable of building PAEK test articles. Laboratory-type environment: experiment with build strategies, measure shape distortions accurately.
- Experience with topology-, shape- and fibre reinforcement optimisation, the corresponding sensitivity analysis (both for shape- as well as for topology optimization) and prior work on design optimisation algorithms for 3D cases involving process simulation and optimization with uncertainties.

5. Abbreviations

PAEK Polyaryletherketone

X. JTI-CS2-2018-CFP09-AIR-02-76: Cost analysis software platform for evaluating innovative manufacturing technology for SMART fuselage

Type of action (RIA/IA/CSA):		RIA	
Programme Area:		AIR	
(CS2 JTP 2015) WP Ref.:		WP B-4.3.6	
Indicative Funding Topic Value (in k€):		400	
Topic Leader:	Imperial College London	Type of Agreement:	Implementation Agreement
Duration of the action (in Months):	24	Indicative Start Date (at the earliest)⁷⁴:	Q3 2019

Topic Identification Code	Title
JTI-CS2-2018-CFP09-AIR-02-76	Cost analysis software platform for evaluating innovative manufacturing technology for SMART fuselage
Short description	
The aim of this call is to develop an open source software to allow full cycle cost analysis for innovative composite manufacturing for fuselage barrels. The software will include technical cost models that accurately reflect the real production environment to correctly evaluate the business case behind new product development. In addition, the cost drivers will include multi-factor sensitivity analysis to understand the trade-off between different process parameters.	

Links to the Clean Sky 2 Programme High-level Objectives ⁷⁵				
This topic is located in the demonstration area:		Cabin & Fuselage		
The outcome of the project will mainly contribute to the following conceptual aircraft/air transport type as presented in the scene setter:		Advanced Turboprop, 90 pax		
With expected impacts related to the Programme high-level objectives:				
Reducing CO₂ emissions	Reducing NO_x emissions	Reducing Noise emissions	Improving EU Competitiveness	Improving Mobility
<input type="checkbox"/>	<input type="checkbox"/>	<input type="checkbox"/>	<input checked="" type="checkbox"/>	<input type="checkbox"/>

⁷⁴ The start date corresponds to actual start date with all legal documents in place.

⁷⁵ For further info see Chapter 1 "Introduction to the Programme Scene Setter / Objectives" with key technology themes / demonstration areas. Detailed information available in the CS2 Development Plan accessible via the Clean Sky JU Website and EC Participant Portal.



1. Background

This Call for Proposal is issued as part of Clean Sky 2 Joint Technology Initiative in which several demonstrators will be developed by the industry.

The call will contribute to the activities in Airframe ITD WP B-4.3.6: SHERLOC (Structural Health monitoring, manufacturing and Repair technologies for Life management Of Composite fuselage). The main activities within the SHERLOC project are directed towards two main areas:

- Advanced methodologies and technologies for maintenance/repair and NDI/SHM
- Manufacturing and testing for validation and verification

They address, in particular, the improvement of the current advanced technologies and methodologies with the aim to make them ready for the industrialization phase of a new regional aircraft fuselage.

Sub-component to be manufactured and tested within SHERLOC is a fuselage panel which is composed of skins, stringers and frames; Floor Beam, Pressure Bulkhead, Window Frame and fittings. These components will be sub-assembled with maximum level of integration and reducing assembling work.

The Partner that will be selected for this Call will be responsible for developing an open source generic software platform to be delivered to the Topic Manager and following technical specifications agreed by the Topic Manager.

2. Scope of work

The objective of the call is to develop a multidisciplinary optimization open source software with an included cost model for composite fuselage design, manufacturing, repair and maintenance. The cost model shall include the economic benefit or otherwise of on-board structural health monitoring technologies (SHM) such as Piezoelectric transducers and Fibre optic sensors. The motivation for cost estimation and cost modelling emanates from the desire to economise the future manufacturing costs before or during the product design phase as well as minimizing the costs of maintenance through SHM technologies. The SHERLOC-Cost-Optimisation open source software (outcome of this call) shall allow for cost estimation and economic comparison of different manufacturing route (e.g. hand layup, automatic tape layup, automatic fibre placement, resin transfer moulding, injection moulding, thermoplastic forming, etc.). The models can be primarily based on detailed cost model estimation method, however, parametric models, mathematically derived are also to be integrated into the software.

SHERLOC-Cost-Optimisation software shall provide a flexible and transparent cost estimation process with appropriate statistical confidence values. The software shall provide platform to adopting different cost estimation strategies generally adopted within the aeronautics industry, namely:

- Analogous cost estimation (based on actual historical data with cause and effects understood)
- Parametric cost estimation (statistical uncertainty of the forecast; allows for scope of quantifying risk)
- Bottom-up estimation frame work for all new products and manufacturing routines.

The development of generic cost estimation model utilizing information is of importance as different sub-components have different elements with specific costs attributed to each part. For example, the generic element's cost attributes may include geometry, material, process and production planning as depicted in Figure 1. The method follows the bottoms up cost estimation approach.

The software shall include technical cost models that accurately reflect the real production environment to correctly evaluate the business case behind new product development. The cost drivers shall include multi-factor sensitivity analysis to understand the trade-off between different process parameters.

The above cost estimation software shall provide a seamless link to the maintenance and direct

operating cost modules also to be developed as part of the call as well as industrial commercially available multidisciplinary optimisation and FE software described below.

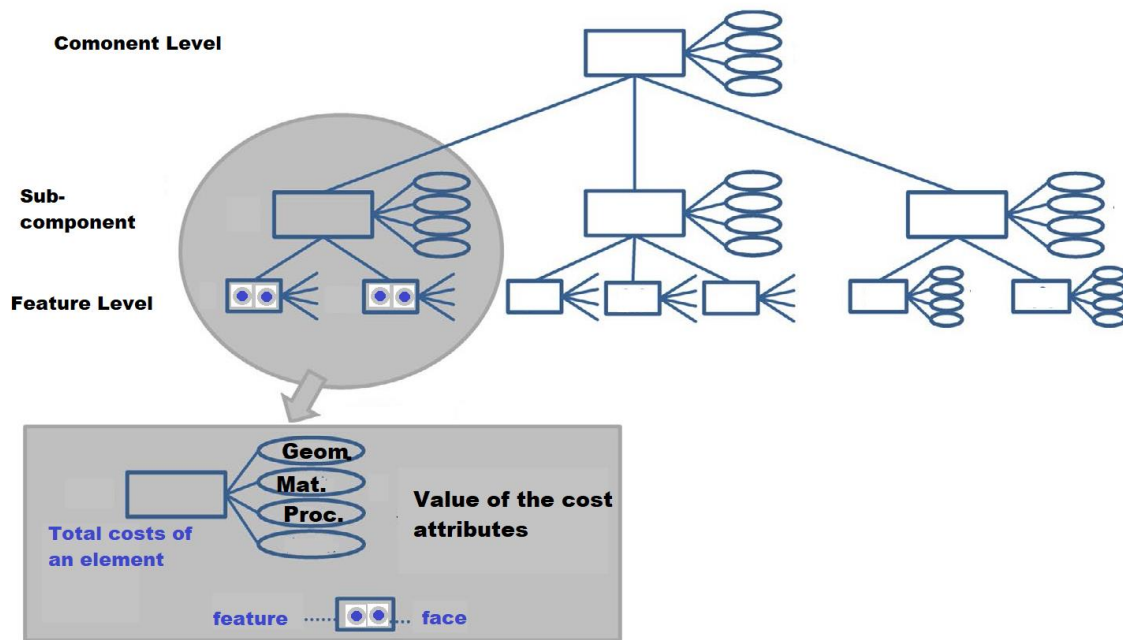

Figure 1 - Cost estimation model

In addition, the software for cost benefit analysis shall allow for incorporation of additional third-party modules such as probabilistic risk assessment (based on SHM diagnosis and prognosis) to evaluate the overall value of the SHM system for each structural part. A Bayesian based Dynamic Data Driven Application System (DDDAS) presented in Figure 2 will be developed by the topic manager and shall be integrated into the software platform. The Bayesian based module developed within the SHERLOC project allows the characterization of uncertainty, and with the appropriate inference network they allow conditional probabilities to be determined in terms of what is known about the structure from the model and what is measured during the inspection.

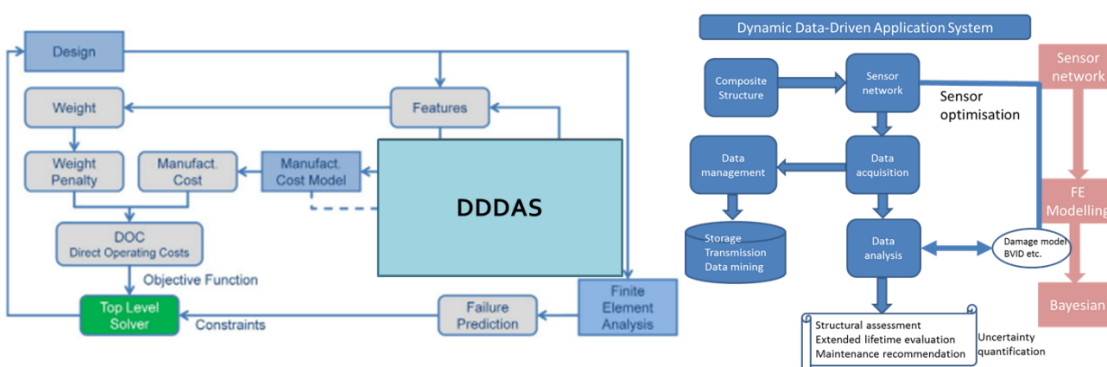
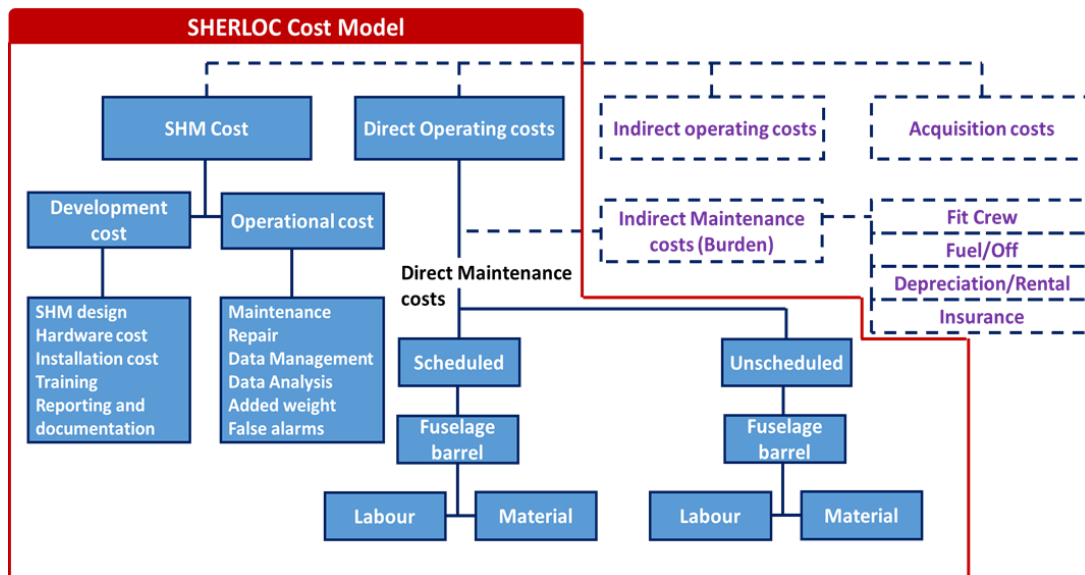

Figure 2 - Bayesian based Dynamic Data Driven Application System

During the design of a sub-component, selection has to be done of the main characteristic to be optimised. However, if this is done in isolation without looking at future costs, there is a risk that small benefits gained from the optimised characteristics are achieved at high cost. Therefore, the SHERLOC-Cost-Optimisation software platform shall provide the benefit of automated simultaneous optimisation

in tandem with the cost estimation. This module shall link the developed cost model software to a multidisciplinary optimisation software such as Isight. The link with these programs shall allow the user to use a parametrised model of the part to automatically generate CAD models with varying geometry and part parameters such as layup, skin thickness and stringer height. The Finite Element program will provide the necessary analysis of these CAD models. The iterative optimisation process will be repeated for all design parameters and passed on to the cost module where the cost of the design is evaluated.



Software Requirements

The software shall:

- Be open source and written in Python.
- Be modular, easy to extend and modify.
- Be able to retrieve from and store data to databases and spreadsheets.
- Provide communication with other software components (i.e. Abaqus, Isight).
- Be able to be used through a GUI.
- Create, open, save and close projects.
- Generate results as a report.

The Partner will be closely supported by the Topic Manager during the development of the software platform.

- The Partner shall:
- Develop an open source software for cost estimation based on the scope of the work defined above.
- Develop cost models for composite part, manufacturing and repair processes,
- Develop interface with multi-disciplinary design optimisation and non-linear finite element software,
- Ensure that the software is readily modular and extendable to allow for integration of additional capabilities such as SHM cost benefit analysis,
- Work closely with the topic manager to ensure good level of integration with the software modules developed within the SHERLOC consortium,
- Provide costs estimates of the 5 sub-components manufactured in collaboration with the SHERLOC consortium using the three different cost estimation approaches,

- Ensure the cost models accurately reflect the real production environment to correctly evaluate the business case behind new product development.
- Ensure the cost drivers include multi-factor sensitivity analysis to understand the trade-off between different process parameters.

Tasks		
Ref. No.	Title - Description	Due Date
T1	Definition of the software architecture	T0+03
T2	Analogous cost estimation module	T0+06
T3	Parametric cost estimation module	T0+09
T4	Generic cost estimation module	T0+12
T5	Development of interface module with non-linear finite element and Multidisciplinary Optimisation software	T0+18
T6	Development of maintenance and direct operating cost modules	T0+24
T7	Incorporation of Bayesian based Dynamic Data Driven Application System	T0+24

3. Major Deliverables/ Milestones and schedule (estimate)

*Type: R=Report, D=Data, HW=Hardware, SW=Software

The dates for deliverables and milestones are indicated below.

Deliverables			
Ref. No.	Title - Description	Type*	Due Date
D1	Software architecture	R	T0+3
D2	Analogous cost estimation module software (including costs estimates of the 5 sub-components manufactured within SHERLOC)	SW+R	T0+06
D3	Parametric cost estimation module (including costs estimates of the 5 sub-components manufactured within SHERLOC)	SW+R	T0+09
D4	Generic cost estimation model (including costs estimates of the 5 sub-components manufactured within SHERLOC)	SW+R	T0+12
D5	Interface module with non-linear finite element and Multidisciplinary Optimisation software	SW+R	T0+15
D6	Maintenance, repair and direct operating cost modules	SW+R	T0+18
D7	SHERLOC-Cost-Optimisation open source software Incorporating the Bayesian based Dynamic Data Driven Application System	SW+R	T0+24

Milestones (when appropriate)			
Ref. No.	Title - Description	Type*	Due Date
M1	Generic cost estimation model (including costs estimates of the 5 sub-components manufactured within SHERLOC)	SW+R	T0+12
M2	SHERLOC-Cost-Optimisation open source software Incorporating the Bayesian based Dynamic Data Driven Application System	SW+R	T0+24



4. **Special skills, Capabilities, Certification expected from the Applicant(s)**

- Expertise in developing cost models for composite parts
- Expertise in development of open-source modular software platforms
- Experience and knowledge of multi-disciplinary optimization
- Experience and knowledge of non-linear finite element analysis
- Knowledge of composite manufacturing, repair and maintenance processes and costs
- Knowledge of estimating operative cost for transport aircraft
- Experience of uncertainty quantification analysis for developing manufacturing cost models

5. **Abbreviations**

SHM	Structural Health Monitoring
DDDAS	Dynamic Data Driven Application System
GUI	Graphic User Interface
NDI	Non Destructive Inspection
FE	Finite Elements
CAD	Computer Aided Design

XI. JTI-CS2-2018-CFP09-AIR-03-06: Calibrating Ultrasonic Sensors for atmospheric corrosion

Type of action (RIA/IA/CSA):		RIA	
Programme Area:		AIR	
(CS2 JTP 2015) WP Ref.:		WP C-2.1.3	
Indicative Funding Topic Value (in k€):		1500	
Topic Leader:	Dassault Aviation	Type of Agreement:	Implementation Agreement
Duration of the action (in Months):	36	Indicative Start Date (at the earliest)⁷⁶:	Q3 2019

Topic Identification Code	Title
JTI-CS2-2018-CFP09-AIR-03-06	Calibrating Ultrasonic Sensors for atmospheric corrosion
Short description	
This project aims at calibrating sensors based on ultrasonic sensors, passive (Acoustic Emission) and active (Pulse Echo), for atmospheric corrosion monitoring, with two modes of use: Cumulative corrosion sensors, and Real time detection of developing damages (cracks, pits).	

Links to the Clean Sky 2 Programme High-level Objectives ⁷⁷				
This topic is located in the demonstration area:			Eco-Design	
The outcome of the project will mainly contribute to the following conceptual aircraft/air transport type as presented in the scene setter:			Low Sweep Business Jet	
With expected impacts related to the Programme high-level objectives:				
Reducing CO ₂ emissions	Reducing NO _x emissions	Reducing Noise emissions	Improving EU Competitiveness	Improving Mobility
<input type="checkbox"/>	<input type="checkbox"/>	<input type="checkbox"/>	<input checked="" type="checkbox"/>	<input type="checkbox"/>

⁷⁶ The start date corresponds to actual start date with all legal documents in place.

⁷⁷ For further info see Chapter 1 "Introduction to the Programme Scene Setter / Objectives" with key technology themes / demonstration areas. Detailed information available in the CS2 Development Plan accessible via the Clean Sky JU Website and EC Participant Portal.

1. Background

Corrosion sensors have been developed for decades [1][2] and proposed for aircraft maintenance. Yet, operators and manufacturers remain cautious about them. One reason is the difficult calibration of atmospheric corrosion sensors. Fitting them to aircraft (DO 160 qualification) is one step, not trivial, but fitting their signals to specific maintenance actions, and controlling the false alarm rate (false positive or negative) is a challenge. The purpose of this project is to calibrate corrosion sensors on few practical cases:

- Pitting , intergranular and exfoliating corrosion
- Filiform corrosion
- Stress corrosion
- Fatigue on corroded materials (not to mistake with fatigue corrosion. Initiation is different).

It will consider surface treatments and self-healing coatings, as they prevent the development of corrosion at early stages and this drastically. Mandatorily it will consider:

- PPG PAC 33 polyurethane primer
- MAPAERO P60 epoxy primer
- PPG CA7521 epoxy (chromate free) primers

Other chromate free primers may be proposed. The release of inhibitors in electrolyte is the self-healing mechanism of the three primers above, but not of all chromate free candidates.

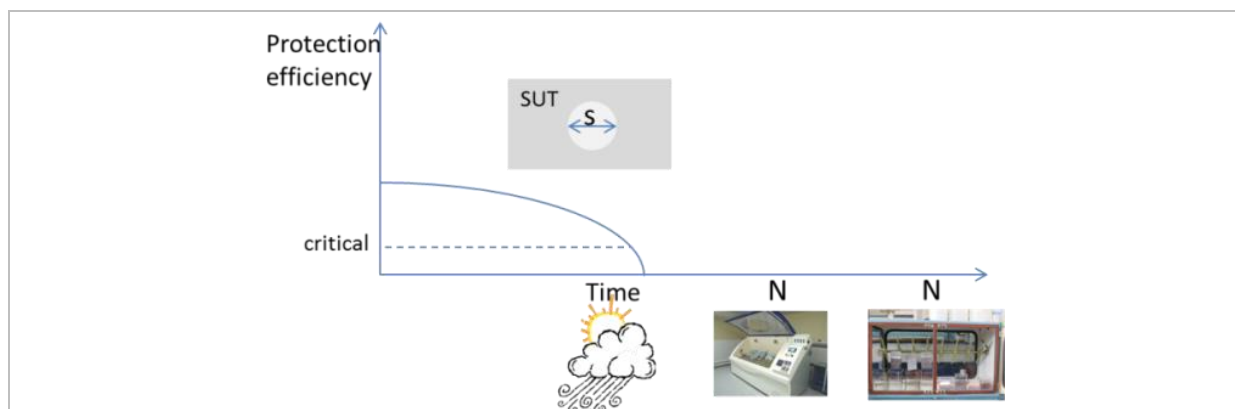

Figure 1. Aging curve of coating nearby a defect. In this example (not necessarily in the project), defect is a circular uncoated spot with surfaces. It is the System Under Test (SUT). X axis is either the time spent outdoor at a given place, or the number N of alternate salt spray tests, or the number N of alternate immersions/emersions. Protection efficiency may be defined as the time SUT can sustain exposure to a given corrosive electrolyte until corrosion pits stabilize. This testing electrolyte should not be the DO 160 standard salt spray test 50 g/l 35°C, so corrosive that it does not leave time to inhibitors to be released, but it should be corrosive enough for corrosion to set on quickly (say, few hours). It is suggested 5 g/l salt concentration but this has to be checked: It should be realistic, that is, possibly met on aircraft parked sea shore. It is also suggested to derive protecting time from acoustic emission from SUT exposed to this testing electrolyte.

As long as the SUT is exposed to a reference accelerated (salt spray, emersion/immersion), or open air test, coating ages, and protection efficiency decreases. The driving reason is the depletion of inhibitors. Concentration profiles of inhibitors can be measured directly [11], indirectly by local probes [12] and eventually modeled [2][4].

Figure 1 suggests a method to calibrate a cumulative corrosion sensor:

- Define a realistic corrosion initiator (\Leftrightarrow triggering site \Leftrightarrow defect).

Be aware that this step is tricky in practice! Machining a coupon, or a more complex structure for stress corrosion and fatigue corrosion monitoring, with a defined and reproducible defect (poor adherence of a coating, microscopic crack, etc.) requires skills, patience, and technology.

b) Chose a reference accelerated exposure cycle.

Cycle may depend on the defect. Emersion/immersion for some, and sprays for others. Some defects will be located in hidden part of aircraft, more sensitive to moisture and less to wind and rain.

c) Define a testing electrolyte.

There are analogies between chemical and mechanical damage if we call the electrolyte a chemical stress. When aircraft is parked by sea shore, electrolyte becomes corrosive, and corrosion may start. For coating it is analogous to a static constraint, whereas dry/wet transitions at dawn in open air are cyclic, lighter ones, analogous to fatigue. The protection efficiency we want to model and monitor is defined versus the marine weather, that is, against a tough, yet likely, static stress.

d) Monitor and model protection efficiency of coating

The “model” it is thought about for this project is not a microscale one combining atmospheric pollutants, corrosion products and released inhibitors from conversion layers and coatings. It is a phenomenological “end user” one linking Y to X axis in figure1. Time before corrosion in the testing electrolyte may be measured several ways: electrochemical methods (local probe techniques) [12], high resolution imaging using high energy beams [11] or acoustic emission [9][10]. This latter technique has a potential for both calibrating a cumulative corrosion sensor (\Leftrightarrow monitor corrosion of the selected defect), in laboratory, and monitoring it in operation, that is, to tell anytime where the coating is on the aging curve, via a pattern analysis of emitted signals.

Though we trust in AE for monitoring risk of corrosion (sensor emits the signal in this mode of use), modeling inhibitor’s release along the reference cycle may deserve more precise methods, like Transmission Electron Microscopy [11], X-ray tomography (a NDT method requiring large infrastructures like Synchrotron) or spatially resolved electrochemical probes [12]. Selecting AE as the unique probing method in this project would be risky.

e) Monitor and model development of corrosion and damages at early steps:

- corrosion pits
- crack initiation (for stress corrosion and fatigue on corroded elements)

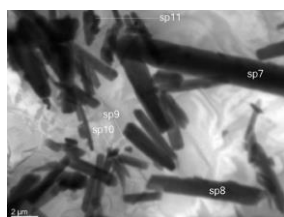

Figure 2.a, reprint from [11]: Transmission Electron Microscopy (TEM) image of the SrCrO₄ particles (main inhibitors) in the epoxy matrix



Figure 2.b, reprint from [12]. Glass micro electrodes used to measure pH and potential of the electrolyte at edge of a defect in a PPG PAC 33 polyurethane coating. A mass transport model solved with FEM was used to deduce Cr(VI) ion concentration gradients during release.

f) Monitor and model protection efficiency of coating, this time in open air facility, on the same components.

It may seem straightforward to cross monitor inhibitor’s release on many samples, exposed to open air and accelerated test, then derive average conversion factors to answer the basic question: “how many reference cycles is worthy a one day parking open air at this place?”. Yet corrosion drivers are complex. Discontinuities of electrolyte for millimeter size (and larger) triggering spots limit coating’s

efficiency [11][4]. Inhibitors are extracted but can't make their way to the pits, and the only protection left is conversion layer.

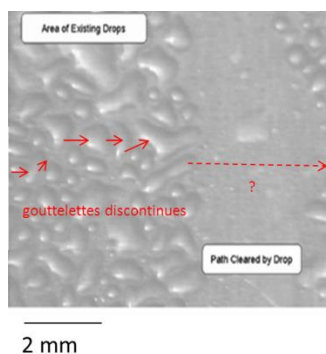

Figure 3. Droplet distribution over a centimeter sized coupon exposed to salt spray test [11]. Droplets much smaller than defect (uncoated area) become unprotected corrosion triggering spots

1 to 4 mm defect size as in BAe SENTINEL® first two slots is typical of a fastener having lost protective coating. It is a use case worthy to address, yet less preoccupying in practice than stress corrosion, fatigue corrosion (and fatigue on corroded materials), or filiform corrosion. Those induce larger damages, much more expensive to repair. For those it is expected a continuous electrolyte deposition, as triggering sites are smaller. SUT of figure 1 may be designed small (a pinhole in coating). The risk is to get very long corrosion times with state of art self-healing coatings. Lowering inhibitors' concentration might be an option [11]. Eventually, of course, protection efficiency of a coating shall be modeled for realistic triggering sites and state of art coatings.

g) Calibrate a cumulative corrosion sensor.

Monitoring corrosion is not the purpose of this project. Purpose is calibration! In coordination with Topic Manager, who will provide some practical cases, critical level of damages shall be defined for the real structures.

Partners shall prove that they can trigger a reference defect on the active part of the sensor, so that it emits acoustic emission bursts when critical damage is at risk to happen on the structure.

Partners shall develop a basic software (Excel or Matlab GUI would do) telling:

- For an assumed and modeled initial defect on the real structure, the size sensor's initial defect should have (ex: radius if it is circular as in Figure 1).
- How many reference cycles the structure bearing the assumed defect could sustain before critical damage sets on.
- How long time in open air exposure at a selected place this structure could stay before similar levels of damage happen.

As input, users shall specify constraints, initial defect, coatings, surface treatments, and (when required) fatigue model.

Cumulative atmospheric corrosion sensors calibration is bulk of the project, but real time corrosion and mechanical damage sensors are also part of it. For early steps of development (initiation, pit growth), it is recommended AE possibly correlated with other data (acceleration, humidity [3]) which may help discriminating the type of damage (pits and stress corrosion preferentially develop at ground, and fatigue in operations).

For crack and damage monitoring beyond initiation, active techniques (pulse echo) could be more relevant [7]. Partners shall review state of art techniques and propose a TRL 4 to 5 demonstrator, that is a ground experiment only, but on a representative large structure.

The real time monitoring shall enable operator to infer on a crack development versus a predefined “critical” threshold (at least, assumed so). This inference will be taken for a calibration of the real time sensor, in coherence with project title. Calibration goes slightly beyond Structural Health Monitoring, which could limit the detection of damage at early stage.

Calibration of the real time sensor (or set of sensors) shall be as much as possible performed on the same samples than those used for calibrating the cumulative sensor. There are standard test components for stress corrosion (bone shaped, U shaped, rings, four point assemblies) that could be used, or non-standard fitted for the testing apparatus. This will be discussed with the Topic Manager. A larger test rig bearing several defects will be provided by the Topic Manager.

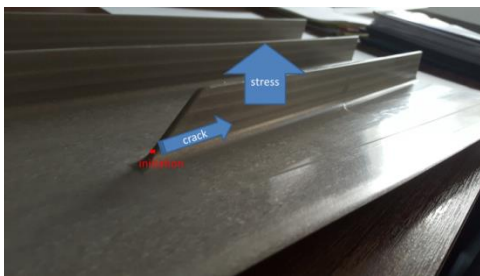
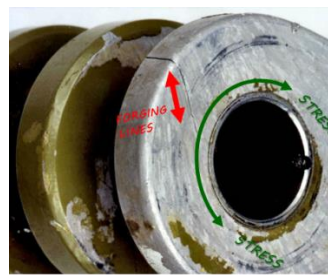
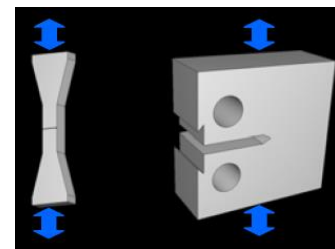

Figure 4.a: A possible base for the demonstrator. Stress corrosion develops along the stiffener. Fatigue can be initiated by a V scratch on the panel, and cycled constraints parallel to it. Panel will be coated. Filiform corrosion can be developed at panel’s edges or by a defect of adherence.



4.b: Another example of stress corrosion that could be tested. Forging lines drive crack direction.



4.c: Normalized test components of stress corrosion.

[9] uses pressurized water to stress a cylindrical shape (mock up of fuselage). Could be interesting if water can contribute to corrosion.

References (not exhaustive, but giving a background):

- 1) Vinod. S. Agarwala: Corrosion sensor and monitoring. NACE International Corrosion. 2000
- 2) Harris, Hebborn: Corrosion Sensors to reduce aircraft maintenance, NATO RTO-MP-AVT-144
- 3) J.Demo, F.Friedersdorf : Wireless Corrosion Monitoring for Evaluation of Aircraft Structural Health, Luna Innovations Incorporated.
- 4) Christine M.Scala, Australian Innovation in Structural Health Monitoring for Aeronautical and Marine Applications, 19 Word Conference on No Destructive Testing, and references therein, particularly [7]: A.Trueman, A. Butler & Al, Laboratory validation of sensors for a corrosion prognostic health management system for use with military aircraft.
- 5) Samuel Benavides: Corrosion control in the aerospace industry, Elsevier, 2009.
- 6) Staszewski , Boller, Tomlinson: Health Monitoring of Aerospace Structures: Smart Sensor Technologies and Signal Processing. Wiley ed
- 7) Pawel Kudela & al: Structural Health Monitoring system based on a concept of Lamb wave focusing by the piezoelectric array. Mechanical Systems and Signal Processing 108 (2018) 21–32
- 8) Miguel A. González Núñez: Acoustic Emission Testing for the Detection of Localized Corrosion of Aluminum 2024 alloy in 3.5% NaCl. 2014 Airlines for America Nondestructive Testing Forum
- 9) J.J Lucas.: Acoustic Emission Fatigue Crack Monitoring of a Simulated Aircraft Fuselage Structure. PhD 2010, Embry-Riddle Aeronautical University.
- 10) S.Furman & Al. Modelling inhibitor release kinetics in self repairing systems. Proceedings of first



international conference on self healing materials, Noordwijk Netherlands, 2007.

- 11) A.E.Hughes & al: Using X ray tomography, PALS and Raman spectroscopy for characterization of inhibitors in epoxy coatings, *Progress in Organic Coating* 74, 2012, 725-733.
- 12) R. Oltra, F.Peltier: Influence of mass transport on the competition between corrosion and passivation by inhibitor release after coating breakdown, *Progress in Organic Coatings* 92, 2016, 44–53
- 13) ZHEN-LONG HU, Pattern Recognition Study of Acoustic Emission Signals of Aircraft Fatigue Cracking, <https://www.ndt.net/article/jae/papers/29-309.pdf>

2. Scope of work

The project shall produce two TRL5 (minimum TRL4) demonstrators of

- Calibration of cumulative corrosion sensors.
- Real time detection and monitoring of active corrosion and cracks

Only ground validation is targeted. No airborne experiment will be conducted. Yet both sets of sensors shall be compatible with operational constraints (sizes, masses, robustness, electromagnetic emissions, etc.).

A methodology shall be suggested to calibrate corrosion sensors with respect to microstructural atmospheric corrosion of aluminium alloys. The Topic Manager has made proposals above, but partners are not bound to them.

A NDT monitoring of corrosion inhibitors is mandatory, and X ray tomography suggested.

Anticorrosion primers MAPAERO P60 and PPG PAC 33 and CA7521 are mandatory and other REACH compliant coatings welcome.

A software, with friendly interface, shall be developed, enabling end users to:

- Model an initial defect in a zone of aircraft. Specify the protection scheme (conversion layers and coatings).
- Estimate corrosion development along the reference cycle.
- Estimate corrosion development in one or two open air sites.
- Select sensor's design parameters (concentration of inhibitors or defect size).

Tasks		
Ref. No.	Title – Description	Due Date
WP1	Specifications	T0 + 6
WP2	Reference and accelerated corrosion test.	T0 + 12
WP3	Corrosion monitoring and modeling. Calibration of a panel of corrosion sensors	T0 + 34
WP4	Real time corrosion and crack detector.	T0 + 35

WP1: Specifications. End T0+6

This task shall specify the systems under tests: Mechanical components, mechanical stress and initial defects. A methodology shall be proposed to calibrate corrosion sensors with respect to microstructural atmospheric corrosion of aluminum alloys.

A methodology shall also be proposed for real time monitoring of corrosion and cracks, and calibration of real time sensors. Based on literature reviews, partners experience and preliminary lab tests (if needed, and on samples partners will provide and prepare in this case), selected technology will be acoustic emission, active (pulse echo) technologies, or a mix.

A mid-term review, after extensive tests on realistic samples, will enable some technology switches and methodology update, yet testing time would be reduced and more sample machining needed.

WP2: Reference and accelerated corrosion test. End T0+12

This task will be split in three subtasks.

WP2.1: Atmospheric corrosion setups and sensor equipment. End T0+6

This task shall specify technologies to be used for corrosion monitoring and modelling (example: spectroscopy, acoustic emission, salt spray chamber, etc.).

WP2.2: Reference cycle for atmospheric corrosion modelling. End T0+12

A reference cycle shall be defined and realized, for each system under test (SUT). By example: Alternate salt spray. It will combine exposition to atmospheric corrosion, fatigue and stress. Partners shall develop a test rig to submit samples to those conditions.

WP2.3: Open air test facilities. End T0+12

Some open air facilities shall be selected, at minimum one. It is not searched in this project to cover all climates in the world, and it is considered more interesting to properly monitor electrolyte deposition (droplet distribution) and coatings' aging at one or two places, rather than getting poor data from many and devoting budget in sample manufacturing.

WP3: Calibration of atmospheric corrosion sensors

This task will be split in three subtasks.

WP3.1: Preparation of systems to test. End T0+12

In compliance with specifications of WP1:

- Samples to test shall be manufactured, treated (conversion layers) and coated. Topic manager shall contribute, providing at least two large structures. One for indoor tests, one for outdoor. They will be used for real time monitoring of corrosion and cracks demonstration.
- Initial defects will be generated on samples under test: Scratches, corrosion pits, mechanical cracks at sub-visible scale, etc., according to specifications of WP1. Partners will perform this task in cooperation with Topic Manager.

WP3.2: Corrosion monitoring. End T0+30

Components under test shall be exposed to reference cycles and open air tests, according to methodology defined in WP1 and its implementation in WP2.

WP3.3: Cumulative corrosion sensor calibration tool. End T0+34

Using data from WP3.2, a predictive corrosion model for the selected defects (\Leftrightarrow triggering sites) shall be derived. A software shall be developed, enabling end users to design and use cumulative corrosion sensors. End user should specify coatings, shape and loadings of initial defect. Software shall tell how many reference cycles this defect could sustain before critical damage sets on. It shall also tell how long it could stay in a given place, found in a database (which may be limited to one in this project).

WP4: Real time corrosion and crack detector. End T0+34

This task is divided in four subtasks

WP4.1: Preparation of case studies. End T0+6

Maximum synergy with WP3.1 shall be sought for. Basic test components shall be the same.

WP4.2: Preparation of tests. End T0+12

Stress corrosion, fatigue corrosion, intergranular corrosion, filiform corrosion shall be monitored in 3.2 for calibrating the cumulative sensors. The real time detectors shall be tested and calibrated on the same damages, but also on the large test rig bearing several damages, to challenge pattern recognition and localization tools. Fatigue, fatigue on corroded material, and fatigue enhanced by corrosion (fatigue corrosion) shall be included, separately, and mixed on the large test rig.

WP4.3: Corrosion and fatigue tests. End T0+34

Corrosion and fatigue tests shall be performed on case studies defined in WP4.1 and prepared in WP4.2. Capacity to calibrate real time damage sensors shall be established, and false alarms of both types (false positive / false negative) quantified.

WP4.4: Recommendations for airborne real time corrosion and crack sensors. End T0+35

This task shall conclude on the possibility to detect, locate and characterize the nature of a developing structural damage, by a set of real time sensors, and to calibrate them versus predefined levels. Suggestion shall be made for a TRL 6 demonstration.

3. Major Deliverables/ Milestones and schedule (estimate)

*Type: R=Report, D=Data, HW=Hardware, SW= Software

Deliverables			
Ref. No.	Title – Description	Type*	Due Date
D1.1	Selection of aircraft components and damages worthy monitoring. Proposed methodology for calibrating real time and cumulative sensors.	R	T0+6
D1.2	Systems to test available, with surface treatments, but no coatings nor defects	HW	T0+9
D2.1	Indoor/open air tests facilities required for tests	R	T0+12
D2.2	Corrosion and fatigue tests operational	HW	T0+12
D3.1	Systems to test prepared, with coatings and initial defects.	HW	T0+12
D3.2	Corrosion test results and corrosion models of selected system	R	T0+34
D3.3	Software tool for cumulative corrosion sensor calibration	SW	T0+34
D4.1	Mid-term review. Data analysis methods for real time monitoring of corrosion and fatigue tests reviewed.	R	T0+18
D4.2	Review of real time monitoring of corrosion and fatigue tests.	R	T0+33
D4.3	Recommendation for airborne real time detection of corrosion and cracks	R	T0+35
D5	Final review	R	T0+36

Milestones (when appropriate)			
Ref. No.	Title - Description	Type*	Due Date
M1	Systems under test specified	R	T0+6
M2	Systems to tests available	HW	T0+12

Milestones (when appropriate)			
Ref. No.	Title - Description	Type*	Due Date
M3	Free, fatigue and stress corrosion test facilities (indoor/outdoor) available, Monitoring devices (acoustic/ultrasonic sensors available). Other devices (Kelvin probes, X ray facilities) available and work planned.	HW	T0+9
M4	Corrosion models available	R/HW	T0+33
M5	Software tool for cumulative corrosion sensors design and calibration available	SW	T0+34
M6	TRL4 demonstration of real time corrosion detection, mapping and evaluation of structural damages. Capacity to calibrate a real time sensor.	R	T0+34
M7	Mid-term review.	R	T0+18
M8	Final review	R	T0+36

4. Special skills, Capabilities, Certification expected from the Applicant(s)

- Strong background in corrosion of coated aluminum alloys, and aircraft structures.
- Experience with aircraft coatings and protection schemes.
- Machining capacities.
- Background in mechanical testing (fatigue, stress).
- Background in corrosion monitoring and accelerated tests.
- Background in non-destructive testing, including high energy methods (X rays, neutrons, etc.), acoustic emission, ultrasonic, and structural health monitoring in general.
- Background in advanced signal analysis and pattern recognition.

5. Abbreviations

GUI	Graphic User Interface
NDT	Non Destructive Testing
SHM	Structural Health Monitoring
SUT	System Under Test
SC	Stress Corrosion
AE	Acoustic Emission
TOW	Time Of Wetness

7. Clean Sky 2 – Engines ITD

I. JTI-CS2-2018-CfP09-ENG-01-39: Measurement of rotor vibration using tip-timing for high speed booster and evaluation of associated uncertainties

Type of action (RIA/IA/CSA):		RIA	
Programme Area:		ENG	
(CS2 JTP 2015) WP Ref.:		WP 2.2.5	
Indicative Funding Topic Value (in k€):		500	
Topic Leader:	Safran Aero Boosters	Type of Agreement:	Implementation Agreement
Duration of the action (in Months):	24	Indicative Start Date (at the earliest)⁷⁸:	Q3 2019

Topic Identification Code	Title
JTI-CS2-2018-CfP09-ENG-01-39	Measurement of rotor vibration using tip-timing for high speed booster and evaluation of associated uncertainties
Short description	
Build and validate a complete chain of sensors, acquisition system and tools to permit measurement of rotor vibration of high speed booster. To sustain certification of booster using this measurement topology, uncertainties have also to be evaluated and quantified.	

Links to the Clean Sky 2 Programme High-level Objectives⁷⁹				
This topic is located in the demonstration area:			ENG WP2	
The outcome of the project will mainly contribute to the following conceptual aircraft/air transport type as presented in the scene setter:			Advanced and Ultra Advanced SMR a/c.	
With expected impacts related to the Programme high-level objectives:				
Reducing CO ₂ emissions	Reducing NO _x emissions	Reducing Noise emissions	Improving EU Competitiveness	Improving Mobility
<input checked="" type="checkbox"/>	<input type="checkbox"/>	<input type="checkbox"/>	<input checked="" type="checkbox"/>	<input type="checkbox"/>

⁷⁸ The start date corresponds to actual start date with all legal documents in place.

⁷⁹ For further info see Chapter 1 “Introduction to the Programme Scene Setter / Objectives” with key technology themes / demonstration areas. Detailed information available in the CS2 Development Plan accessible via the Clean Sky JU Website and EC Participant Portal.

1. Background

In the framework of the Ultra High Bypass Ratio engine architecture, especially with a more compact design in comparison with the current direct drive design, the measurements of rotor vibration for a high speed booster (low pressure compressor), made using telemetry/slip ring, result to perform important changes of rotoric parts, to permit integration of instrumentation hardwares, in order to get accurate vibration levels (deformations, frequencies, etc...). Those modifications imply costs and delays which can be incompatible with schedule. In addition, these large modifications could lead to a lack of representativity for some engine parameters (mainly aerodynamic parameters), which can be not acceptable for engineering or certification purpose, implying to repeat some tests in other configurations.

However, this type of measurement can be performed using tip-timing technology where sensors are placed on statoric parts. Even if this method is available for years from different suppliers and permits to measure vibration levels of rotor, uncertainties remain important/unknown for low pressure compressors. This is due to the numbers of (known or unknown) parameters (for instance, clearances, axial positioning, temperature,...) which are not taken into account by actual systems, methodologies or algorithms and also due to the quality of the acquired signal, which is not homogeneous and down-sampled resulting in a complex post processing. With the goal of avoiding telemetry/slip ring system to perform certification, those uncertainties have to be known and quantified to insure safety and margin of the low pressure compressor.

The main objective of this topic is then to build and validate a complete tip-timing chain, which will take into account all relevant physical parameters for high speed low pressure compressors, and will also quantified associated uncertainties. At a first glance, tip clearances measurements should be already taken into account as it appears to have an impact on tip-timing. A validation test should be performed on a representative low pressure compressor rig test vehicle provided by the Topic manager organisation.

2. Scope of work

Tasks		
Ref. No.	Title – Description	Due Date
WP1	Identification of physical parameters	M0+6
WP2	Modelization of physical parameter influences	M0+12
WP3	Tip-Timing chain design and implementation	M0+21
WP4	Tip-Timing chain validation	M0+24

WP1: Identification of physical parameters

Before building and validating a complete chain, it is needed to identify the main physical parameters which can have an influence on vibration level measurements. The aim of this WP is to identify and quantify these parameters and their influence on the accuracy of the measurement. Based on the identified parameters, additional instrumentation should be requested for accurate tip-timing post-treatment during WP4.

WP2: Modelization of physical parameter influences

When identified, modelizations of the different physical parameters on vibration level measurement



have to be performed in order to take them into account during design tip-timing chain. If hardware has to be considered, it is expected to see the software to be the main contributor for the improvement of the accuracy of the vibration level measurement accuracy.

These modelizations will permit to deduce algorithms to take them into account during tip-timing chain design.

WP3: Tip-timing chain design and implementation

When modelizations available, the design phase of the complete tip-timing chain can start. This design will be built from scratch or by adapting existing solution available and already used by the Topic manager organisation, and by using results from modelization and implementing associated algorithms (including softwares).

WP4: Tip-timing chain validation

In this work-package, the tip-timing chain will be tested within physical parameter variations in order to validate hypothesis and algorithms defined in WP2. Test cases will be proposed and implementation will be performed by the Topic manager on a representative low pressure compressor. In order to confront tip-timing results and usual responses, a telemetry/slip ring system would be used to demonstrate the accuracy of the tip-timing chain.

Proposals may include the commitment from the European Aviation Safety Agency to assist or to participate in the action

3. Major Deliverables/ Milestones and schedule (estimate)

*Type: R=Report, D=Data, HW=Hardware

Estimated schedule:

		Year 1				Year 2			
		Q1	Q2	Q3	Q4	Q1	Q2	Q3	Q4
D1	Identification of physical parameter (intermediate)								
D1.1	Identification of physical parameter (intermediate)	■							
D1.2	Identification of physical parameter (final)		■						
D2	Modelization of physical parameter influences (intermediate)								
D2.1	Modelization of physical parameter influences (intermediate)		■	■					
D2.2	Modelization of physical parameter influences (intermediate)				■				
D3	Tip-timing chain design and implementation								
D3.1	Tip-timing chain design				■	■			
D3.2	Tip-timing chain implementation					■	■	■	
D4	Tip-timing chain validation								
D4.1	Tip-timing chain validation					■	■	■	
D4.2	Tip-timing chain uncertainties determination								■

Deliverables			
Ref. No.	Title – Description	Type*	Due Date
D1.1	Identification of physical parameter (intermediate)	R	M0+3
D1.2	Identification of physical parameter (final)	R	M0+6
D2.1	Modelization of physical parameter influences (intermediate)	R	M0+9
D2.2	Modelization of physical parameter influences (final)	R	M0+12
D3.1	Tip-timing chain design	R	M0+15
D3.2	Tip-timing chain implementation	R	M0+21

Deliverables			
Ref. No.	Title – Description	Type*	Due Date
D3.3	Tip-Timing chain implementation (software)	HW	M0+24
D4.1	Tip-timing chain validation	R	M0+24
D4.2	Tip-timing chain uncertainties evaluation	D	M0+24

Milestones (when appropriate)			
Ref. No.	Title – Description	Type*	Due Date
M1.2	Physical parameter study review	R	M0+6
M2.2	Physical parameter influences study review	R	M0+12
M4.2	Final Review	R	M0+24

4. Special skills, Capabilities, Certification expected from the Applicant(s)

Demonstrated capabilities:

- Capability to interpret non-homogeneous under sampled signals
- Capability to build analytical and semi-empirical models of vibration behavior of blades
- Capability to understand the behavior of low pressure compressors
- Capability to build acquisition system and associated softwares (mainly Human Machine Interface)
- Capability to design post-treatment softwares

An Implementation agreement will be proposed to manage the IPR and the relation between the Topic manager and the Applicant(s).

II. JTI-CS2-2018-CfP09-ENG-01-40: Turbulence modeling of heat exchangers and roughness impact

Type of action (RIA/IA/CSA):		RIA	
Programme Area:		ENG	
(CS2 JTP 2015) WP Ref.:		WP 2.5.4	
Indicative Funding Topic Value (in k€):		600	
Topic Leader:	Safran Aero Boosters	Type of Agreement:	Implementation Agreement
Duration of the action (in Months):	36	Indicative Start Date (at the earliest)⁸⁰:	Q3 2019

Topic Identification Code	Title
JTI-CS2-2018-CfP09-ENG-01-40	Turbulence modeling of heat exchangers and roughness impact
Short description	
Manage the turbulent behavior and the roughness in additive manufactured heat exchangers in order to optimize the heat exchangers performances.	

Links to the Clean Sky 2 Programme High-level Objectives⁸¹				
This topic is located in the demonstration area:			ENG WP2	
The outcome of the project will mainly contribute to the following conceptual aircraft/air transport type as presented in the scene setter:			Advanced and Ultra Advanced SMR a/c.	
With expected impacts related to the Programme high-level objectives:				
Reducing CO₂ emissions	Reducing NO_x emissions	Reducing Noise emissions	Improving EU Competitiveness	Improving Mobility
<input checked="" type="checkbox"/>	<input type="checkbox"/>	<input type="checkbox"/>	<input checked="" type="checkbox"/>	<input type="checkbox"/>

⁸⁰ The start date corresponds to actual start date with all legal documents in place.

⁸¹ For further info see Chapter 1 “Introduction to the Programme Scene Setter / Objectives” with key technology themes / demonstration areas. Detailed information available in the CS2 Development Plan accessible via the Clean Sky JU Website and EC Participant Portal.



1. Background

In the framework of such geared turbo fan engine architectures, the thermal management will be one of the most important challenge to face. The heat exchangers are the main products that drive the performances of the thermal management system and the additive manufacturing (AM) has a great potential to optimize their global efficiency. Some important work has been led in order to develop new optimization tools, based on techniques such as topological optimization, leading to radically new structures. These new optimized structures may lead to substantial increase of heat exchanger efficiency, i.e. increase of performances while maintaining a global mass or, on the contrary, increased compactness and weight of the part with a constant global efficiency.

Unfortunately, a gap still exist between these structures optimized at computer scale and the industrial reality: the lack of fundamental knowledge of the new additive manufacturing structures and significant wall roughness impacts on the flow behaviors (pressure loss and heat exchange). Thus, simulation based designs and computational optimization process may lead to inefficient heat exchangers at a real life level: variation in pressure losses and heat exchange due to AM innovative geometries and associated roughness must be perfectly known in order to take them into account in the optimization software and, as a consequence, avoid time loss in the conception phase.

The Computational Fluid Dynamics (CFD) simulation rests upon turbulence and roughness modeling (with more or less accuracy) to predict the flow behavior. The capability to choose the proper modelling is then essential to predict and optimize the heat exchanger performances with the best compromise between pressure drop and heat exchange enhancement.

The aim of this call proposal is to manage the turbulent behavior and the roughness in additive manufactured heat exchangers in order to optimize the heat exchangers performances.

2. Scope of work

The goal of the proposed CfP is to manage the turbulent behavior and the roughness in additive manufactured heat exchangers in order to optimize the heat exchangers performances. For that the work will be split in 5 WP of increasing complexity in terms of AM innovative geometries and integration for CFD 3D simulations.

For all geometries, the range of Reynolds (based on the hydraulic diameter) to study will be between 200 and 20 000. Concerning the relative roughness (vs Hydraulic Diameter), the range to be considered will be between 0 and 0.02. Finally, 3 roughness modeling will be studied : equivalent Sand Grain Roughness, periodic and real/random (thanks to tomography).

For RANS simulations, the ANSYS-Fluent solver (version>18.1) will be used. As for LES simulations, the YALES 2 solver will have to be considered.

The work will be split in 5 main WP, as described below :

Tasks		
Ref. No.	Title - Description	Due Date
WP1	Identification of physical parameters and CFD modeling	M0+9
WP2	Modelization of test cases incompressible internal rough flow	M0+18
WP3	Modelization of test cases compressible internal rough flow	M0+24

Tasks		
Ref. No.	Title - Description	Due Date
WP4	Modelization of two fluids AM heat exchangers	M0+36
WP5	Benchmark of LES modelization on test cases rough flow	M0+36

WP1: Identification of physical parameters and CFD modeling

Before building the modelization of turbulence flow with rough walls, it is needed to identify the main physical parameters which can have an influence on the flow behaviour and how to model the turbulence and the roughness modeling. It is also needed to characterize the “roughness” with dimensional aspects and a link with the roughness measurement methodology for AM parts. Finally, it is necessary to identify test cases (with test or analytical results already available) to compare the modelization results of following work packages and lead a first fundamental modelization on a flat plate for compressible and incompressible laminar to turbulent flows for the identified different roughness parameters and RANS turbulence modeling.

WP2: Modelization of test cases incompressible internal flow

When identified, modelizations of the different roughness parameters and RANS turbulence modeling will be performed on simple test cases (tubes, fins, ...) for internal incompressible laminar to turbulent flows. Results will be compared with test or analytical results identified in WP1 in terms of heat exchange and pressure loss.

WP3: Modelization of test cases compressible internal flow

Same activity as for the WP2 for compressible flow, or incompressible flow with a temperature dependant density ($Mach < 0.3$).

WP4: Modelization of two fluids AM heat exchangers

After the modelization on partial test cases, in this work-package, the two sides of an AM heat exchangers will be simulated for 3 types of applications :

- Two incompressible internal cross flows
- One incompressible and one compressible internal cross flows
- One incompressible internal and one compressible external cross flows

WP5: Benchmark of LES modelization on test cases rough flow

Finally, a benchmark of Large Eddy Simulation (LES) modelization will be conducted on 3 of the previous test cases to address the pros and cons of LES versus RANS simulations.

3. Major Deliverables/ Milestones and schedule (estimate)

*Type: R=Report, D=Data, HW=Hardware

		Year 1				Year 2				Year 3			
		Q1	Q2	Q3	Q4	Q1	Q2	Q3	Q4	Q1	Q2	Q3	Q4
WP 1	Identification of physical parameters and CFD modeling												
D.1.1	Bibliography of roughness and turbulence modeling (application domain and limitations)	■											
D1.2	Roughness characterisation : dimensionnal aspect and link with roughness measurement methodology for AM parts		■										
D1.3	Bibliography test cases and fondamental modelization on flat plate			■									
WP 2	Modelization of test cases incompressible internal rough flow												
D2.1	Square and cylindrical tubes, incompressible flow				■								
D2.2	Straight and strip fins, incompressible flow					■							
D2.3	Square tubes with internal fins, incompressible flow						■						
WP 3	Modelization of test cases compressible internal rough flow												
D3.1	Square and cylindrical tubes, compressible flow						■						
D3.2	Straight and strip fins, compressible flow							■					
D3.3	Square tubes with internal fins, compressible flow								■				
WP 4	Modelization of two fluids AM heat exchangers												
D4.1	Two incompressible internal cross flows										■		
D4.2	One incompressible and one compressible internal cross flows											■	
D4.3	One incompressible internal and one compressible external cross flows												■
WP 5	Benchmark of LES modelization on test cases rough flow												
D5.1	Square and cylindrical tubes, compressible & incompressible flow - LES										■		
D5.2	Straight and strip fins, compressible & incompressible flow - LES											■	
D5.3	Square tubes with internal fins, compressible & incompressible flow - LES												■

Deliverables			
Ref. No.	Title - Description	Type*	Due Date
D1.1	Bibliography of roughness and turbulence modeling (application domain and limitations)	R	M0+3
D1.2	Roughness characterisation : dimensionnal aspect and link with roughness measurement methodology for AM parts	R	M0+6
D1.3	Bibliography test cases and fondamental modelization on flat plate	R,D	M0+9
D2.1	Square and cylindrical tubes, incompressible flow	R,D	M0+12
D2.2	Straight and strip fins, incompressible flow	R,D	M0+15
D2.3	Square tubes with internal fins, incompressible flow	R,D	M0+18
D3.1	Square and cylindrical tubes, compressible flow	R,D	M0+18
D3.2	Straight and strip fins, compressible flow	R,D	M0+21
D3.3	Square tubes with internal fins, compressible flow	R,D	M0+24
D4.1	Two incompressible internal cross flows	R,D	M0+30
D4.2	One incompressible and one compressible internal cross flows	R,D	M0+33
D4.3	One incompressible internal and one compressible external cross flows	R,D	M0+36
D5.1	Square and cylindrical tubes, incompressible flow - LES	R,D	M0+24
D5.2	Straight and strip fins, compressible flow - LES	R,D	M0+30
D5.3	Square tubes with internal fins, compressible internal flow - LES	R,D	M0+36

Milestones (when appropriate)			
Ref. No.	Title - Description	Type*	Due Date
M1	End of WP 1 - Synthesis	R	M0+9
M2	End of WP 2 - Synthesis	R	M0+18
M3	End of WP 3 - Synthesis	R	M0+24
M4	End of WP 4 - Synthesis	R	M0+36
M5	End of WP 5 - Synthesis	R	M0+36

4. Special skills, Capabilities, Certification expected from the Applicant(s)

- Strong expertise in fluid numerical simulations and analysis is required.
- Knowledge of AM process and impact on geometries
- The partner will demonstrate to have recognized skills in:
 - Aerodynamic, Fluid Dynamics and Aerothema
 - High Performance Computing for Computational Fluid Dynamics (CFD) simulations
 - Large Eddy Simulation
 - Aerothema simulation coupling conduction
 - Laminar to turbulent flow simulations
- Available numerical tools to perform the tasks

5. Abbreviations

AM	Additive Manufacturing
CfP	Call for Partner
CFD	Computational Fluid Dynamics
LES	Large Eddy Simulation
WP	Work Package

III. JTI-CS2-2018-CfP09-ENG-01-41: Ground vortex characterization method applicable for engine testing

Type of action (RIA/IA/CSA):		RIA	
Programme Area:		ENG	
(CS2 JTP 2015) WP Ref.:		WP 2	
Indicative Funding Topic Value (in k€):		750	
Topic Leader:	Safran Aircraft Engines	Type of Agreement:	Implementation Agreement
Duration of the action (in Months):	24	Indicative Start Date (at the earliest)⁸²:	Q3 2019

Topic Identification Code	Title
JTI-CS2-2018-CfP09-ENG-01-41	Ground vortex characterization method applicable for engine testing
Short description	
<p>This topic aims at building a method to provide an aerodynamic characterization of the ground vortex in engine crosswind condition, compatible with a degraded instrumentation (i.e. compliant to integration constraints with engine).</p> <p>The method will be developed with the support of a wind-tunnel testing campaign using both detailed and degraded instrumentations and CFD computations simulating the test apparatus, both held in this project.</p>	

Links to the Clean Sky 2 Programme High-level Objectives ⁸³				
This topic is located in the demonstration area:			ENG WP2	
The outcome of the project will mainly contribute to the following conceptual aircraft/air transport type as presented in the scene setter:			Advanced and Ultra Advanced SMR a/c.	
With expected impacts related to the Programme high-level objectives:				
Reducing CO₂ emissions	Reducing NO_x emissions	Reducing Noise emissions	Improving EU Competitiveness	Improving Mobility
<input checked="" type="checkbox"/>	<input type="checkbox"/>	<input type="checkbox"/>	<input checked="" type="checkbox"/>	<input type="checkbox"/>

⁸² The start date corresponds to actual start date with all legal documents in place.

⁸³ For further info see Chapter 1 "Introduction to the Programme Scene Setter / Objectives" with key technology themes / demonstration areas. Detailed information available in the CS2 Development Plan accessible via the Clean Sky JU Website and EC Participant Portal.

1. Background

When a turbojet engine operates at ground conditions and high power, a ground vortex can form and be ingested by the engine intake with a strong effect on fan operability. The vortex strength and its effect on the engine increases on next generation turbofan engines, due to lower ground clearances and higher massflows, and can become a source of concern.

Being able to predict the vortex key characteristics and their effects on fan aeromechanics during the design phase and then to verify these during engine test surveys, is of the utmost importance to ensure a good fan aero-mechanical behaviour. However, deploying the necessary instrumentation on such surveys is often incompatible with the engine integration constraints (stress, intrusiveness, cost, ...).

The goal of this topic is to provide a methodology that will enable one to carry such a characterisation, based on an instrumentation compatible with these constraints and aerodynamic CFD simulations. During this project, a wind-tunnel test campaign using both classic (i.e. compatible with engine test constraints) and detailed (i.e. that permits to fully characterize the ground vortex) instrumentations will be held, and CFD computations simulations made, the outputs of both of which will be used to develop the methodology.

2. Scope of work

Tasks		
Ref. No.	Title - Description	Due Date
Task 0	<p><u>Management and reporting</u></p> <ul style="list-style-type: none"> - Quarterly progress written reports shall be provided by the partner, including technical achievements, updated workplan, inputs and outputs status, financial status, update of the risk analysis and mitigation plan. This report shall be presented during a face to face meeting which will take place alternatively in the partner and Safran Aircraft Engines offices. - Monthly coordination meetings shall be conducted via telecon. - The partner shall support reporting and agreed review meetings with reasonable visibility on its activities and an adequate level of information. <p>The partner shall warn Safran Aircraft Engines if any event has a significant impact on the workplan.</p>	All along the project
Task 1	<p><u>Project launch</u></p> <p>The partner and Safran shall perform a face to face meeting in Safran offices. The partner shall present the risk analysis and the mitigation plan based on the learning of this present document. The partner shall also present the technical means and the relevant projects it has achieved.</p> <p>Safran shall present the background of the project, the deliverables and the workplan target, and specific project requirements. This meeting shall allow to meet the team project on both sides, to define the key roles, to plan the quarterly report meetings and the monthly coordination meetings.</p>	T0 +1 month
Task 2	<p><u>Bibliography and SoA assessment</u></p> <p>The partner shall present the state of the art of numerical methods, instrumentation means, and ground vortex physics.</p> <p>This study will be held with the prospect of determining the optimal simulation and measurement means to be used in the project.</p>	T0 +4 months

Tasks		
Ref. No.	Title - Description	Due Date
	A detailed report will be provide to Safran.	
Task 3	<p>CFD matrix and methodology</p> <p>The partner shall present the strategy of numerical simulation to be used in the project, which will be validated by Safran.</p> <p>Three phases are proposed :</p> <p>A first set of calculation to define test matrix and instrumentation location.</p> <p>A study aiming at maturing the methodology</p> <p>The numerical simulations shall reproduce the configurations defined in 0 as well as the physics of crosswind and ground vortices. In particular the relevant wind tunnel and instrumentation effects shall be meshed to ensure set-up consistency. Simplifications can be done based on this study or based on mutual agreement. At least three unsteady calculations shall be done to validate (or not) the use of RANS methodology.</p> <p>A matrix based on final methodology in order to produce numerical base for comparison.</p> <p>As an order of magnitude, a matrix of 20 calculations is expected for experimental comparison (2 sideslip angles, 3 velocities, 3 engine mass flows, 3 heights).</p> <p>The partner is free to use any CFD tool or methodology (NS or LBM). The post-processing strategy shall be emphasized to ensure a comparison with the test campaign results can be done.</p> <p>Specific metrics should be calculated according to Safran proposal or bibliography outputs (IDC, swirl, circulation, Pt distortion ...).</p>	T0 +6 months
Task 4	<p>CFD analysis</p> <p>The partner shall realize the CFD computations as defined in 0, as well as the post-processing defined in the same Task.</p>	T0 +19 months
Task 5	<p>Test matrix and methodology</p> <p>The wind-tunnel facility will be chosen in this task, and shall be compatible with the description below.</p> <p>300 keuro have been accounted for 2 days of tests.</p> <p>The partner shall present a strategy of wind-tunnel testing with the aim of measuring ground vortex characteristics with the following variations (the envelope of which shall be validated by Safran):</p> <ul style="list-style-type: none"> - Instrumentation ('classic' and 'detailed' instrumentations) - Stabilized crosswind conditions (<2 wind speed (5-20m/s), <2 angles (45-90°)) - Massflow screening (pending on scale – Mach_max~0.65 at flange) - 3 Ground clearances (engine axis height/fan diameter~0.85) <p>The set-up shall include an inlet and a ground simulator – No fan is required but a secondary mass flow shall be produced for the inlet.</p> <p>The model size and wind-tunnel Reynolds number should be representative of a ground operation condition.</p>	T0 +6 months

Tasks		
Ref. No.	Title - Description	Due Date
	<p>The geometry is provided by Safran (length/fan diameter~0.4). The partner can manufacture the model or use metallic model provided by Safran (used in ONERA F1 wind tunnel, scale~6.5, flange diameter=338mm). The model shall respect the manufacturing requirements of Safran. Additive manufacturing can potentially be used if roughness effect is limited or taken into account in CFD calculations (skin friction, laminar transitional).</p> <p>If the Safran model is used, the instrumentation adaptation parts (ring, sting, ...) shall be designed and manufactured by the partner. In the other case, the instrumentation needs can be directly included within the model.</p> <p>The 'classic' instrumentation is based on simple sensors compatible with actual engine test inlet (Pt or Ps, rakes, static or dynamic response). Exotic means can be proposed but need to be agreed with Safran. The 'detailed' instrumentation shall enable to fully determine vortex characteristics (static and dynamic) in wind tunnel environment (5 holes probe, hot wire, PIV, ...).</p> <p>The post-processing of the data acquired during these tests shall be defined jointly with Safran.</p>	
Task 6	<p><u>Test setup specifications and instrumentation</u> The partner shall provide the final test specifications, the assembly plan and the compliance matrix to prove the test vehicle and its instrumentation respect all the requirements previously frozen, in particular the test matrix determined in 0.</p>	T0 +9 months
Task 7	<p><u>Test setup design and assembly</u> The partner shall provide a 3D assembly drawing of the test setup, including the installation within the wind-tunnel and instrumentation, compatible with the project objectives.</p>	T0 +12 months
Task 8	<p><u>Test setup manufacturing</u> The partner shall provide the test hardware as defined in 0. The test hardware will either be manufactured or adapted from an already existing inlet design, provided by Safran, to allow instrumentation integration. Manufactured hardware will be the property of Safran.</p>	T0 +15 months
Task 9	<p><u>Test campaign</u> The partner shall conduct the test campaign, in agreement with the test matrix defined in 0, with the participation of Safran. The partner shall write a daily report to share the key events and preliminary results. Each test will have sufficient number of test points to verify the repeatability of said test and to later analyze the test results and compare with numerical results.</p>	T0 +16 months
Task 10	<p><u>Test results post-processing</u> The partner shall analyze the test campaign data and compare it with</p>	T0 +18 months

Tasks		
Ref. No.	Title - Description	Due Date
	preliminary numerical results or bibliography data, and available previous test data. The partner shall provide the full set of data for the test campaign before and after post-processing, as well as the post-processing tools used.	
Task 11	<u>Vortex assessment method development</u> The partner shall develop a method that allows one to assess a ground vortex characteristics in an engine test rig configuration without advanced instrumentation, for instance with low fidelity instrumentation and the support of CFD simulations. The results obtained in the previous tasks will be used to help determine and validate the method.	T0 +22 months
Task 12	<u>Final report</u> The partner shall write the final report and present a summary during a face to face meeting in Safran offices with all the project team. This report shall include the technical work but also a feedback on the project (evolution and efficiency of the risk analysis, evolutions of the workplan, feedback on the organization). A special attention will be paid to the methodology developed during the project and the degree in which it answers the initial problematic.	T0 +24 months

3. Major Deliverables/ Milestones and schedule (estimate)

*Type: R=Report, D=Data, HW=Hardware

Deliverables			
Ref. No.	Title - Description	Type*	Due Date
D1	Project launch report (0)	R	T0 +1 month
D2	Bibliography report (0)	R	T0 +4 months
D3	CFD test matrix and methodology report (0)	R	T0 +6 months
D4	Mesh, scripts, CFD computations pre-processing, results and post-processing (0)	D	T0 +19 months
D5	Test matrix and methodology strategy report (0)	R	T0 +6 months
D6	Test vehicle specifications (0)	R	T0 +9 months
D7	Test vehicle assembling drawings, CAD, instrumentation plan and design documents (0)	D	T0 +12 months
D8	Test vehicle hardware (manufactured, 0)	HW	T0 +15 months
D9	Test result report, as well as all recorded raw data (0)	R + D	T0 +16 months
D10	Test post-treated data and analysis (0)	R + D	T0 +18 months
D11	Vortex assessment methodology report (0)	R	T0 +22 months
D12	Final report (0)	R	T0 +24 months

Milestones (when appropriate)			
Ref. No.	Title - Description	Type*	Due Date
M1	Test and CFD methodology strategy available	R	T0 + 6 months
M2	Test setup available	HW + D	T0 + 15 months

Milestones (when appropriate)			
Ref. No.	Title - Description	Type*	Due Date
M3	Test campaign post-processed	D + R	T0 + 18 months
M4	Vortex assessment methodology available	D + R	T0 + 22 months

Task	Owner	Title	Timeline																								
			T0	+1	+2	+3	+4	+5	+6	+7	+8	+9	+10	+11	+12	+13	+14	+15	+16	+17	+18	+19	+20	+21	+22	+23	+24
0	Partner	Management and reporting																									
1	Partner / Safran	Project launch																									
2	Partner	Bibliography and SoA assessment																									
3	Partner / Safran	CFD matrix and methodology																									
4	Partner	CFD analysis																									
5	Partner / Safran	Test matrix and methodology																									
6	Partner	Test setup specs. and instrumentation																									
7	Partner	Test setup design and assembly																									
8	Partner	Test setup manufacturing																									
9	Partner	Test campaign																									
10	Partner	Test results post-processing																									
11	Partner	Method development																									
12	Partner	Final report																									

4. Special skills, Capabilities, Certification expected from the Applicant(s)

- Project and risks management
- Build a test campaign in wind tunnel tests facilities representative in Mach, Reynolds number and crosswind requirements
- Advanced (aerodynamic) measurement capabilities and skills
- Technical skill for CFD computations (pre, solver, post)
- Advanced Turbomachinery knowledge

5. Abbreviations

NS/3D	Navier Stockes / Three-Dimensionnal
LBM	Lattice Boltzman method
SoA	State of the Art

IV. **JTI-CS2-2018-CfP09-ENG-01-42: Additive manufacturing boundary limits assessment for Eco Design process optimization [ECO]**

Type of action (RIA/IA/CSA):		RIA	
Programme Area:		ENG [ECO]	
(CS2 JTP 2015) WP Ref.:		WP 2.5	
Indicative Funding Topic Value (in k€):		1500	
Topic Leader:	Safran	Type of Agreement:	Implementation Agreement
Duration of the action (in Months):	36	Indicative Start Date (at the earliest)⁸⁴:	Q3 2019

Topic Identification Code	Title
JTI-CS2-2018-CfP09-ENG-01-42	Additive manufacturing boundary limits assessment for Eco Design process optimization
Short description	
<p>Additive manufacturing techniques give access to a huge variety of new potential parts design and structure, sometimes not feasible through conventional manufacturing techniques. New part shape optimization calculation tools are currently being developed, but need fundamental inputs in order to define boundary limits linked to the global performances of additive manufacturing. The goal of the topic is to work on a series of elementary specimens made of powder bed laser technique, representative of a heat exchanger pattern in order to build a common database of performances (fluid, thermal) mapped with key design parameters (geometry, manufacturing process). This database will then be applied to a test case in order to evaluate the optimization potential. Due to the relevance of the activity in the field of novel manufacturing processes and associated data base the topic is associated to the Eco Design Transverse activity.</p>	

Links to the Clean Sky 2 Programme High-level Objectives⁸⁵				
This topic is located in the demonstration area:		Eco design - Advanced Engine/Airframe Architectures		
The outcome of the project will mainly contribute to the following conceptual aircraft/air transport type as presented in the scene setter:		Advanced Short/Medium-range Ultra-advanced Short/Medium-range		
With expected impacts related to the Programme high-level objectives:				
Reducing CO₂ emissions	Reducing NO_x emissions	Reducing Noise emissions	Improving EU Competitiveness	Improving Mobility
<input checked="" type="checkbox"/>	<input type="checkbox"/>	<input type="checkbox"/>	<input checked="" type="checkbox"/>	<input type="checkbox"/>

⁸⁴ The start date corresponds to actual start date with all legal documents in place.

⁸⁵ For further info see Chapter 1 "Introduction to the Programme Scene Setter / Objectives" with key technology themes / demonstration areas. Detailed information available in the CS2 Development Plan accessible via the Clean Sky JU Website and EC Participant Portal.

1. Background

Additive manufacturing has a great potential in terms of parts design and optimization in the field of aero-engines in particular advanced gear turbofans and high efficiency engines where an increased amount of energy has to be dissipated in cooling fluids.

This topic is targeted to heat exchangers and heat recovery systems optimization through the investigation of advanced additive manufacturing techniques and tools.

Some important work has been led in order to develop new optimization tools, based on techniques such as topological optimization, leading to radically new structures. These new optimized structures may lead to substantial increase of heat exchanger efficiency, i.e. increase of performances while maintaining a global mass or, on the contrary, increased compacity and weight of the part with a constant global efficiency.



Figure 1: Selective Laser Melting of Micro Turbines recuperator

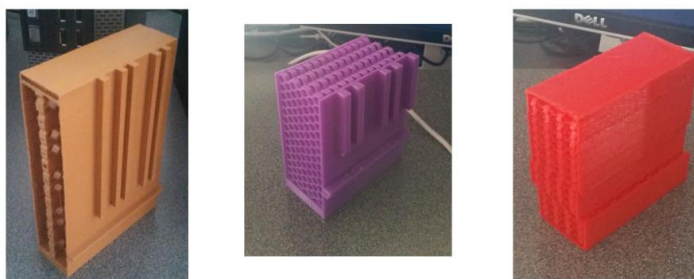

Figure 2: Heat exchanger optimisation

Unfortunately, a gap still exists between these structures optimized at computer scale and the industrial reality : the lack of fundamental knowledge of additive manufacturing limits in terms of microstructures (grain size, roughness, fin thickness) and associated performances may lead optimization tools to propose unrealistic structures at a real life level : high pressure losses due to rugosity, mechanical failures due to wall thickness, the boundary limits of the process (i.e. the acceptable limits in terms of optimization potential with respect to final properties of the parts) have to be known in order to take them into account in the optimization software and, as a consequence, avoid time loss in the conception phase.

The work proposed aims at optimizing the Additive Manufacturing process on several points:

- Allowing an optimization of material used for the same efficiency, by finding for instance the optimal wall thickness in heat exchangers. The result will consequently be a reduced part weight, and a lowered powder use. This vision perfectly fits with the Eco Design Transverse Activity goal (Eco-Design TA will mainly focus on materials, processes and resources sustainability, efficient manufacturing and production, lifetime service, and end-of-life, and shall also consider emerging aspects coming from future requirements to be met).
- Allowing to assess the potential of AM to build parts with radically new architecture and, as a consequence, to access to new potential applications or to optimize existing ones (reduction of heat exchanger weight, new shapes, increased efficiency for the same weight...)
- Allowing to optimize the conception phase of heat exchangers. As described above, some new

conception tools, based on topological optimization for instance, allow to draw radically new heat exchanger concepts. Nevertheless, these tools do not take into account the industrial “manufacturability” of such parts, inducing increased development costs due to the huge number of tests to be led before assessing the certificability of such part. The work proposed aims at reducing this development time / cost / energy by assessing the limits of AM and include these limits in the design tools. A lot of data already exist on the manufacturing part using AM (energy, powder consumption), but the conception / design part is still mainly unknown. The work will as a consequence come as a perfect complement of the work already been done on additive manufacturing process.

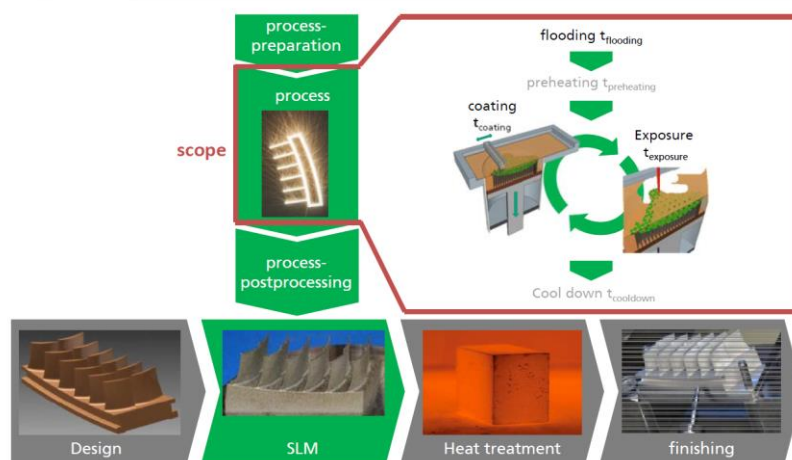

Figure 3: Optimisation process

The aim of this call proposal is to understand the link between the additive manufacturing process, the microstructure, the performances and how these parameters can be integrated in a design tool. Due to the relevance of the activity in the field of novel manufacturing processes and associated data base the topic is associated to the Eco Design Transverse activity led by Fraunhofer.

2. Scope of work

The goal of the topic is to study the boundary limits of additive manufacturing applied to heat exchanger manufacturing. For that, a series of sample parts will be manufactured with a precise geometry and, in a second step, characterized according to a series of properties. The sample part geometries will be defined in order to build a matrix of AM running conditions. All the results will be gathered in a global database. The proposed topic consequently aims at understanding the influence of LBM (Laser Beam Melting) process parameters on exchanger type key design functions

The work will be split in 4 main WP, as described below :

Application : Heat Exchanger

Objective: Material data for proper Heat exchanger design assessment

Safran inputs	Specification	SubTask 2 : Samples manufacturing	SubTask 3 : Sample characterization	SubTask 4 : Design assessment
	<ul style="list-style-type: none"> Test definition (samples representative of heat exchanger geometry/ tests representative of heat exchanger solicitation) Test matrix (DOE based on influent process parameters) Test definition and matrix to be provided by OEMs and assessed with the supplier (feasibility, cost, delays...) 	<ul style="list-style-type: none"> Design of sample parts Receiving Powder and control Manufacturing & job report Samples control Several types of samples will be considered, each sample will be adapted to the tests to be performed. All samples will be very simple geometries Manufacturing may include finishing steps (chemical dissolution...) 	<ul style="list-style-type: none"> Test tooling Tests & post tests analysis Test report Type of tests to be performed (non exhaustive list) : <ul style="list-style-type: none"> Analysis of dimensional deviation from initial design Rugosity Aerothermal characterization (Colburn/Nusselt coefficient, Fanning coefficient) of exchange surfaces on a given Reynolds range Characterisation of equivalent stiffness on specific samples (specific design) <ul style="list-style-type: none"> airtightness / watertightness + pressure resistance Analysis of walls porosity 	<ul style="list-style-type: none"> Basic heat exchanger design with « previous » data Basic heat exchanger design with CdP data Design comparison Assesment of Eco-D potential

Propriété de Safran. Ils ne doivent pas être copiés ni communiqués à un tiers sans l'autorisation préalable et écrite de Safran.

Tasks		
Ref. No.	Title - Description	Due Date
1	Specifications	T0+ 3
2	Sample manufacturing	T0+ 20
3	Sample characterization	T0+ 24
4	Eco Design assessment	T0+ 36

Task 1 : Specifications

This task will be dedicated to

- Refine the description of test sample geometry and characterization with the applicant.
- Define the strategy for the final Eco-assessment (manufacturing and characterization of an industrial test case)
- Define the manufacturing and characterization plannings, with definition of sample priorities.

Task 2 : Sample Manufacturing

In this task, a series of parts will be manufactured, following a Design of Experience strategy. The detailed description of work is provided below.

- **Sample Type**

The samples set are composed of several types of simple designs, each geometry being dedicated to a certain type of characterization:

E1 : Small sample, very simple design, dedicated to surface state characterization. The volume of the samples is less than 30cm³

E2 : Larger dimension sample, but still with a simple design, in order to lead aerothermal characterizations (Colburn and Fanning coefficient as function of Reynolds). The number of this type of sample will be limited. The volume of the samples is higher than 400cm³

E3 : Small sample, dedicated to pressure resistance and airtightness tests. The volume of the samples is less than 300cm³.

E4 : Small sample, geometry dedicated to equivalent stiffness characterization. The volume of the samples is less than 50cm³

The objective of these burst pressure tests and stiffness characterization (with E3 and E4 samples) is to study the link between the exchanger structure (roughness, thickness) and mechanical properties.

- Heat exchange surface pattern geometry: All geometry samples will be based on non-confidential simple pattern geometry of classical plate and fins heat exchangers type with rectangular cross-section and hydraulic diameter of about 1-4 mm. The fins geometry would be a priori plain fins. However in order to achieve non-vertical building orientation (for E2 samples) or increase the number of intermediate building orientation (for E1 samples) the fins and/or plates would be with wavy pattern (for E1 the pattern could vary in the same sample in order to scan a large interval of building orientation). Depending the cost of each sample manufactured and first characterizations results, the applicant could also manufacture and perform characterization of more complex classical plate and fins sample geometries such as plate and wavy fins or perforated fins (with rectangular cross-section and hydraulic diameter of about 1-4 mm similarly the first ones).
- Powder: The applicant shall supply the In718 and AS7G06 powders and ensure compliance with Safran powder specification (AS7G06 and In718 SLM powder materials specification will be provided by Safran under NDA). Two samples must be taken for further analysis if necessary. One of the two samples of powder should be sent to Safran for analysis.
Storage and recycling method/recycling rate : Before every process, a recycled powder sample will be saved. The gathered samples will be evaluated according to Safran SLM powder specification in terms of change in morphology, oxygen content, composition, sphericity and flowability (Safran powder specification will be provided by Safran under NDA)
- Samples Manufacturing
 - LBM equipment: The samples shall be produced on powder bed laser equipment compatible with material and sizing (for example EOS M400 / M290). The applicant shall demonstrate and ensure compliance with Safran process specification (will be provided under NDA). Furthermore, tensile testing samples (Z-axis) will be fabricated and tested for each plateau. (Rm minimum requirements = tbd MPa for In718 and tbd MPa for AS7G06)
 - Process parameters: the process parameters window for the processing of dense samples compliant with Safran process requirements will be evaluated as follow:
 - Building orientation: horizontal, vertical and at 45°C from plateau axis (production file) (Priority 1)
 - Layer Thickness: from 20µm, up to 80µm (Priority 1)
 - Scanning strategy: 3 different to be proposed by the applicant (Priority 1)
 - Scanning speed: 3 different to be proposed by the applicant (Priority 1)
 - Laser power (Priority 1)
 - Manufacturing platform temperature/thickness (Priority 2)

Safran will propose a Design Of Experiments plan (DOE), to be discussed with the applicant, for each of the functional tests identified in order to assess the parameters of primary impact of part design function. This DOE plan will also include the samples finition type (either net shape or chemical treated).

All operating procedures, cleaning methods, job reports, set up, oxygen rate, recoater type and "aging" (time of use), filter type and "aging", (time of use) shall be recorded by the applicant for

each production.

- Post treatment
 - Thermal Treatment: A thermal treatment of detention will be carried out. This stress relief cycle will be done before the cutting plate and will be followed by a cleaning (departicling/powder removal) of the parts (mechanical or US). Then samples will be removed from plate and post treated (Thermal treatment cycles will be provided by Safran as well).
 - Samples Preparation: Cutting method, sand blasting/shot peening and machining/manual operation to be proposed by applicant to meet samples drawing requirements.
 - Finition: Chemical treatment or alternative to be proposed by applicant.

All samples shall be dimensionally checked in order to verify part conformity with drawings. Two sample types of each plateau must be taken for further analysis if necessary. One of the two samples should be sent to Safran for analysis.

Tentative DOE proposal for IN718 materials, same for AS7G06

Tests Type	Wall thickness	Finishing	Building orientation	Layer thickness	Scanning strategy	Scanning speed	Estimation of samples qty
A1 (rugosity and porosity)	W1 W2 W3	Net shape "polished"	V 45° Intermediate value (tbc)	T1 T2 T3	SS1 SS2 SS3	SP1 SP2 SP3	>50
A2 (waterproofness & pressure proof)	W1 W2 W3	Net shape "polished"	V 45° Intermediate value (tbc)	T1 T2 T3	SS1 SS2 SS3	SP1 SP2 SP3	>50 combination wall & layer thickness, finishing & building orientation
A3 (equivalent stiffness)	W1 W2 W3	Net shape "polished"	V 45° Intermediate value (tbc)	T1 T2 T3	SS1 SS2 SS3	SP1 SP2 SP3	>50 combination wall & layer thickness, finishing & building orientation
A4 (aerothermal test)	W1 W2 W3	Net shape "polished"	V 45° Intermediate value (tbc)	T1 T2 T3	SS1 SS2 SS3	SP1 SP2 SP3	>20

The final test matrix may be reduced by selection of the most critical parts by a discussion with the applicant, according to budget and planning constraints.

The choice samples E2 for aerothermal test should depend on A1, A2, A3 tests results.

Task 3 : Sample characterization

The following characterization will be made on each point of the DOE. As described above, specific samples will be provided by the Task 2 according to the type of characterization :

- Surface properties (samples E1) :
 - Rugosity (Ra, second order momentums)
 - Grain size and grain morphology (ideally surface 3D characterization)
- Dimensional properties :
 - Dimensional characterization. Characterization of the dimension deviation from CAD.
- Experimental aerothermal performances evaluation (sample E2) :
 - Aerothermal performances by determination of the Fanning and Colburn coefficients on a large range of Reynolds comprising $Re=1000$ to $Re=6000$ with Reynolds based on hydraulic diameter wich must be of about 1-4 mm.
- Experimental gas tightness and pressure resistance evaluation (samples E3)
 - Control of gas tightness by Helium tests (type of gas to be discussed with applicant)
 - Control of pressure resistance by burst pressure test and leak detection (for example Helium pressure drop $<100 \text{ mbar.h-1}$)
- Experimental mechanical properties (samples E4)
 - Characterization of equivalent stiffness for thick wall sample

For each sample of E2 type (for aerothermal test) manufactured and tested, samples of E1/E3/E4 type of the equivalent geometry and manufacturing parameters could be manufactured and tested (but not reciprocally).

For each characterization, the applicant should provide all the details of the test characteristics (temperature, pressure, duration, apparatus...).

Task 4 : Numerical study and comparison with test results

For A2/A3/A4 tests type, numerical study must be performed based on “ideal” surface (without roughness) CAD in order to compare them with sample characterization.

The main interest of these numerical simulations is to evaluate the deviation (order of magnitude) between the real behavior (mechanical and aerothermal) of thin & rough surfaces by additive manufacturing compared to the theoretical behavior of ideal thin surfaces with usual additive manufacturing properties. An important decrease or increase of mechanical/aerothermal properties according to the thickness/ building orientation/finishing could be emphasized by this study. This would allow to improve the knowledge of the ability of AM to manufacture thin walls for heat exchanger with acceptable mechanical and aerothermal properties.

Another interest of this study is to prepare the models and tools for the final evaluation.

- For A2/A3 tests type, finite element computations should be performed and compared with experimental results
- For A4 tests type CFD simulations would be performed and ideally with LES (Large Eddy Simulation) models. For the comparison with experimental data, these simulations may be coupled with OD models.

The modelling tools and modelling approach will be discussed between the applicant and Safran, based on applicant proposal.

Task 5 : Final Design Assessment

Using the database results of Task 2 and Task 3, Safran will propose a specific design of heat exchanger (optimized wall thickness, angles). The applicant will then and provide two samples CAD model:

- A sample representative of the design based on the initial state of art additive of manufacturing

limitations (before optimization)

- A sample representative of the design after optimization.

Each sample will be manufactured and characterized according to Task 2 and Task 3 requirements.

The results will be provided to the topic manager and the CS2 aeronautical Eco Design data base managed by Fraunhofer in order to allow an evaluation of the Eco potential for the engine applications by using compatible data sets and format according to Eco-design Transverse Activity methods and tools. This database may then be used in several applications in order to build models and to optimize part structures.

3. Major Deliverables/ Milestones and schedule (estimate)

*Type: R=Report, D=Data, HW=Hardware

Deliverables			
Ref. No.	Title - Description	Type*	Due Date
D1	Choice of E1/E3/E4 samples geometric characteristics	R	M2
D2	Final test matrix, with detailed sampling manufacturing and characterization plan	R,D	M3
D3	Furnishing of the full sample database (for E1 , E3, E4 samples types only)	R, HW	M7
D4	Report of all the E1, E3 and E4 samples experimental and numerical characterization results	R, D	M11
D5	Choice of E2 samples characteristics based on D3	R	M12
D6	Furnishing of the full sample database for E2 samples	R, HW	M16
D7	Report of all the E2 samples experimental and numerical characterization results	R, D	M20
D8	Provide Eco Design LCI documented data sets and correlations vs process conditions from AM processes, as required by Safran and FhG for Eco-assessment.	D, R	M26
D9	Final Eco Design Test report	D, R,HW	M36

Milestones (when appropriate)			
Ref. No.	Title - Description	Type*	Due Date
M1	Review of E1/E2/E4 design and A1/A2/A3 test conditions	R	M1
M2	Technical review of A1/A2/A3 manufacture, characterization results and E2 Design and test conditions	R	M12
M3	Technical review of A4 result	R	M26
M4	Technical review of Final Eco Design and testing	R	M36

4. Special skills, Capabilities, Certification expected from the Applicant(s)

- Applicant will have proven experience in manufacturing complex metallic parts using up-to-date additive manufacturing techniques.
- Applicant will have proven experience in Heat Exchanger design, modelling and manufacturing Applicant will have proven experience in complex characterization of metallic parts (rugosity, porosity, mechanical properties) and experimental evaluation in aerothermal properties



(Colburn/Fanning coefficients measurement).

- Applicant shall be qualified according to ISO 9001 /EN 9100
- Capability to understand Eco Design and measure and collect LCI data for industrial processes

5. **Abbreviations**

AM	Additive manufacturing
CfP	Call for Proposal
LCI	Life Cycle Inventory
LBM	Laser Beam Melting
WP	Workpackage
NDA	Non Disclosure Agreement
SLM	Selective Laser Melting
DOE	Design of Experiment
3D	3 dimension
CAD	Computer Aided Design

8. Clean Sky 2 – Systems ITD

I. JTI-CS2-2018-CfP09-SYS-01-11: Machine learning to detect Cyber intrusion and anomalies

Type of action (RIA/IA/CSA):		IA	
Programme Area:		SYS	
(CS2 JTP 2015) WP Ref.:		WP 1	
Indicative Funding Topic Value (in k€):		500	
Topic Leader:	Thales	Type of Agreement:	Implementation Agreement
Duration of the action (in Months):	24	Indicative Start Date (at the earliest)⁸⁶:	Q3 2019

Topic Identification Code	Title
JTI-CS2-2018-CfP09-SYS-01-11	Machine learning to detect Cyber intrusion and anomalies
Short description	
<p>The objective is to design an aircraft onboard security filter with an accuracy level of intrusion detection compatible with cyber protection objectives.</p> <p>The topic focuses on the use of machine learning techniques to enable the detection of cyber intrusion due to vulnerabilities on legacy ground-to-air digital exchanges to avionics.</p> <p>This domain is totally different to machine learning in operational avionics functions like guidance or control laws as the cybersecurity domain concerns defensive capacities and not model based behaviour.</p>	

Links to the Clean Sky 2 Programme High-level Objectives ⁸⁷				
This topic is located in the demonstration area:		Enabling technologies		
The outcome of the project will mainly contribute to the following conceptual aircraft/air transport type as presented in the scene setter:		Enabling technologies		
With expected impacts related to the Programme high-level objectives:				
Reducing CO ₂ emissions	Reducing NO _x emissions	Reducing Noise emissions	Improving EU Competitiveness	Improving Mobility
<input type="checkbox"/>	<input type="checkbox"/>	<input type="checkbox"/>	<input checked="" type="checkbox"/>	<input type="checkbox"/>

⁸⁶ The start date corresponds to actual start date with all legal documents in place.

⁸⁷ For further info see Chapter 1 “Introduction to the Programme Scene Setter / Objectives” with key technology themes / demonstration areas. Detailed information available in the CS2 Development Plan accessible via the Clean Sky JU Website and EC Participant Portal.



1. Background

Air-ground data exchanges have been the subject of decades of research and standardization work and are an essential ingredient of the future operational concepts since they can carry reliably richer information than what can be exchanged over radio.

ATC use of datalink is widely expanding over the years. The main operational needs are driven by the following economic objectives:

- Operational Effectiveness
- Automation for Crew Operation Effectiveness
- Reduce direct operating costs - via optimized departure/tracks/arrival negotiation (ATC)
- Delay & regularity / Fuel consumption reduction / Environmental Emissions (CO₂)

Increase of the airspace capacity, enhancement of the operational efficiency while ensuring the best safety level of the air traffic cannot be done without a combined use of the air and ground elements. Numerous actors play in this global end-to-end concept, which can be seen as a chain linking a pilot and a controller.

Data communications are a key enabler sustaining SESAR/NextGen services, deployment being planned in the 2020+. The deployment of 4D business/mission trajectories, using CPDLC and ADS-C applications, is the cornerstone for trajectory based operations. These new services will impose more demanding performance, safety and security requirements upon the air-ground datalink.

Up to now, ATC links (including ACARS sub-networks, through VHF/VDL2 or HF/DL or classic aero SATCOM) are considered implicitly trusted. Today's ATC systems are fed with data from sensors that have little security measures. For example legacy data transmission is not encrypted for existing datalink capabilities and protocol like ATN, ACARS, VHF digital modes (i.e. the ones used for legacy ATC datalink exchanges). As a consequence in practice it is very hard to identify if failure is a malfunction or an attack. Any end-to-end security solution can be only made if there is a coordinated deployment of functions of safety on board and on the ground. No standard of end to end security of the links enabling ATC authentication and integrity has been deployed, neither planned to be deployed (even if research has been conducted and standards proposed). Europe & US security considerations explain in detail the assumptions made on the acceptability of such risks.

ACARS & ATN vulnerabilities are known but considered «acceptable» by airworthiness authorities (in the current operational environment). In anticipation of future more secured datalink solutions, it is essential in the short term to investigate measures to make the current systems more resilient against cyber-threats.

In the absence of such end-to-end deployment, it may still be possible to define effective and automated solutions for intrusion detection.

These threats result from legacy channels of communication and exchange of data (radio and network levels). Ground data infrastructures and data transactions performed with the ground ATC are considered as being of confidence, but are realized through "over the air" radio media of communication exposed to threats.

The objective is to check/control data from the ground domain before authorizing them to enter the avionics domain not to compromise this level of safety. The flow of data is checked, analyzed by cyber detection function of implemented in an on-board cyber proxy.

These techniques would provide in depth defence (applicative message filtering) and allow to reach a level of safety less important than an end-to-end protections, but nevertheless significant. An important



point to note is the application to the domain of defensive capacities that enforce robustness, totally different from operational avionics functions like guidance or control laws.

In the state of the art, security controls for applicative filtering are necessarily performed on massive volumes of data - with determinist analysis based on detection by recognition and filtering. Only an alert is raised, whose reliability is limited (important number of false-positive detection).

The objective is to use Machine learning based on air-ground data to characterise air-ground data (frequency, sequencing, header, payload and other available parameters) with security point of view (security model)

- first in nominal conditions
- then with intrusion attempt scenarios

in order to elaborate an accurate filtering security control that :

- maximize intrusion detection (reduce False negative)
- minimize false positive (that is a weakness in more classical approaches base on system modelling)

2. Scope of work

The activities will focus on Artificial Intelligence / Machine Learning techniques applied on collections of incoming / outgoing air-ground data traffic.

- Detection of anomalies by non-determinist learning (machine learning)
- Increase in efficiency / Robustness in detection of anomaly in the data transactions
- Anticipation of incident & Reaction with non-fatal sanction

The topic work will allow to:

- Analyze feasibility of machine learning techniques for Cyber Detection of intrusion and anomalies
- On-Board Continuous Monitoring Operational parameters / air-ground data exchanges

Expected output is:

- Prototype tool both for the learning phase (off-board) and for the implementation phase (onboard)
- Adapted models for implementation onboard aircrafts

Applicant will provide input data required for this work. These could be either available with the applicant or collected from other sources, in which case, applicant should have means to collect, record and process flight data of commercial aircraft.

As cyber-attacks continuously evolve, the counter-measures will have to periodically be upgraded during the life of the system. Hence the tool shall be designed to be easily updatable (and in timely manner – typically 5 minute-upload during turn-over) directly on already-installed functions on-board an aircraft.

The main activities and deliverables are sketched in the table below, however, applicant are encouraged to propose alternate approach to ensure achievement of the topic objectives.

Tasks		
Ref. No.	Title – Description	Due Date
WP1	Technical resources and problem definition	T0 + 2 months
WP2	Security Model requisites	T0 + 4 months
WP3	Air-ground data collection	T0 + 12 months
WP4	Tools development	T0 + 14 months
WP5	Build and validate the Security Model	T0 + 22 months
WP6	Security Filtering development	T0 + 24 months

WP1 : Technical resources and problem definition

The objectives of this work package are to:

- describe technical resources (input data, initialization data, validation means),
- define technical problem (use cases & functional scope, modelling assumptions),
- define technical requirements (interfaces, accuracy, performance...) for models and modeling tools,

WP2 : Security Model environment

In order to be able to elaborate the security model, the objectives of this work package are to:

- choose and describe the relevant method for modelling (« Misuse-based », « Anomaly-based », « Hybrid »)
- define and describe the learning tools
- define and describe verification and validation tools (scenarii, criteria).

WP3 : Air-ground data collection

Activities of this work package are:

- establish the list of data to be collected, their sampling characteristics, and the means to collect/record these data
- define and describe the data processing to be performed on collected data for subsequent use by machine learning
- provide the processed data to be used as inputs for security model.

WP4 : Tools development

The objectives of this work package are to:

- develop tools for learning phases according to the design established in WP2,
- develop tools for validating phases according to the design established in WP2,
- WP4 is expected to be performed in parallel to WP3

WP5 : Build and validate the Security Model

The objectives of this work package are to:

- build the security model
- validating the security model according to WP2

WP6 : Security Filtering development

The objectives of this work package are to:

- Define security filtering from security model
- develop security filtering module that could be embedded in an avionic suite



- WP6 is expected to be performed in parallel to WP5

3. Major Deliverables/ Milestones and schedule (estimate)

Deliverables			
Ref. No.	Title – Description	Type	Due Date
D1.1	Technical Resources and problem definition		T0 + 2 months
D2.1	Security model environment description document		T0 + 4 months
D3.1	Air-ground data collection report		T0 + 12 months
D4.1	Modelling and Validation Tools Package (first release)		T0 + 14 months
D4.2	Validation Test Plan		T0 + 14 months
D5.1	Security Model and Test Report		T0 + 22 months
D5.2	Modelling and Validation Tools Package final release		T0 + 22months
D6.1	Security Filtering definition		T0 + 24 months
D6.2	Security Filtering module		T0 + 24 months

4. Special skills, Capabilities, Certification expected from the Applicant(s)

- Collaboration with Airlines , Ground datalink providers and ATM organisations is encouraged to collect air-ground data and validate the security model
- Data collection and processing: Capability to collect/record and process air-ground data. This includes capture, storage, analysis, data curation, search, sharing, transfer, visualization, querying, updating and information privacy.
- Modeling technologies (machine learning): High level of experience and skill in the machine learning domain.
- Knowledge on air-ground data standards and air-ground datalinks

5. Abbreviations

ADS-C	Automatic Dependent Surveillance Contract mode
ACARS	Aircraft Communications Addressing And Reporting System
AI	Artificial Intelligence
ATC	Air Traffic Control
ATM	Air Traffic Management
ATN	Aeronautical Telecommunications Network
CPDLC	Controller Pilot Datalink Communications
HFDL	High Frequency DataLink
SATCOM	Satellite Communications
SESAR	Single European Sky ATM Research
VDL2	VHF Datalink mode 2
VHF	Very High Frequency



II. JTI-CS2-2018-CfP09-SYS-01-12: Software engine for multi-criteria decision support in civil aircraft flight management

Type of action (RIA/IA/CSA):		IA	
Programme Area:		SYS	
(CS2 JTP 2015) WP Ref.:		WP 1.3	
Indicative Funding Topic Value (in k€):		600	
Topic Leader:	Thales	Type of Agreement:	Implementation Agreement
Duration of the action (in Months):	24	Indicative Start Date (at the earliest)⁸⁸:	Q3 2019

Topic Identification Code	Title
JTI-CS2-2018-CfP09-SYS-01-12	Software engine for multi-criteria decision support in civil aircraft flight management
Short description	
The objective is to provide a software engine model for supporting crew decisions in the context of operations for civil aircrafts, with a better understanding of the stakes of the current mission, from the perspective of the business objectives of the airline. This topic focuses on the use of multi-criteria decision techniques to enable aided choice among a set of alternatives against several possibly conflicting criteria.	

Links to the Clean Sky 2 Programme High-level Objectives⁸⁹				
This topic is located in the demonstration area:		Cockpit and Avionics		
The outcome of the project will mainly contribute to the following conceptual aircraft/air transport type as presented in the scene setter:		Advanced Long and Short/Medium Range		
With expected impacts related to the Programme high-level objectives:				
Reducing CO₂ emissions	Reducing NO_x emissions	Reducing Noise emissions	Improving EU Competitiveness	Improving Mobility
<input type="checkbox"/>	<input type="checkbox"/>	<input type="checkbox"/>	<input checked="" type="checkbox"/>	<input checked="" type="checkbox"/>

⁸⁸ The start date corresponds to actual start date with all legal documents in place.

⁸⁹ For further info see Chapter 1 “Introduction to the Programme Scene Setter / Objectives” with key technology themes / demonstration areas. Detailed information available in the CS2 Development Plan accessible via the Clean Sky JU Website and EC Participant Portal.



1. Background

In the context of the mission driven operations for civil aircrafts, pilots should have on board a better understanding of the stakes of the current mission – from the perspective of the business objectives of the airline - and all the controls to improve the adherence to the intended mission.

In the frame of Clean Sky 2 ITD System, strategic functions for flight management are looked after. Several individual functionalities for flight alternatives assessment, flight optimisation for specific phases and diversions capabilities are matured. On top of these, a virtual assistance block is needed to help pilots choose a specific action. This already existing need will be even more important in the wake of reduced crew operation.

Individual missions depend on many factors, ranging from the business model of the airline, to the time in the day of operation (busy hour...), and including the constraints from the previous and next missions of the aircraft and the crew. As a consequence, the drivers for setting the targets vary for each and every flight.

Although the priority given to safety is undisputed, flight crew also have to ensure adherence to other criteria of performance, in line with the airline objectives: it is expected that the expectation on crew performance measurement and improvement will increase in the future⁹⁰. This creates the need of new tools to support the crew in:

- assessing the situation of flight against the objectives set by the airline
- taking decision to reach the required performance.

The global approach in which the call subject is inserted is to:

- Understand the types of performance the airline are seeking
- Translates these into high level objectives
- Express each high level objective in measurable parameters, define the parameterized formulae to compute them
- Define a way to present a current status vis-à-vis the 'contract' and the pilot – systems interaction to provide to the crew the required level of information, decision aids and control options.

Mission of a flight crew can be defined very simply : safely fly passengers from point A to point B. Obviously, additional criteria and constraints add some complexity to this simple contract : adherence to schedule, ATC rules, specific airline procedures, objectives of cost reduction, etc. This necessary leads to trade-offs.

The various parts of the trade-offs will be perceived and weighted differently, depending on the stakeholders (citizen, passenger, airline): here the focus is on the airline as the main stakeholder.

Elements of potential influence can be grouped in four main key performance areas which are:

- Cost, regrouping all the direct elements having an impact on the cost of the flight
- Time, gathering parameters contribution to the adherence to a given flight schedule
- Green or Environment regrouping all parameters impacting the environment at large (noise, gaseous emissions, etc)
- Satisfaction regrouping all the parameters perceived by a passenger.

⁹⁰ See for example 'Air France et le Carburant' Mastere ENAC 23/11/2009. – Conduite du changement PNT



Those four key performance areas are not fully independent but interconnected (e.g fuel consumption has a direct contribution to Cost (cost of fuel) and Green (CO₂ and NO_x emission)).

Each of the key performance areas:

- is the aggregation of several elementary contributing items
- can be associated with an airline dependent utility function

The objective of the call is to design and implement a prototype software engine for trading and ranking different alternatives in terms of pilot actions, to best comply with the airline policy mix.

For instance, if late at some stage during the flight, which is the best alternative to recover, considering airline policy: increase speed, change flight level or negotiate a short cut with ATC?

The trading of alternatives is dependent of the global key performances mix set up by the airline, on the airline network, and on the specific departure and destination airports.

2. Scope of work

The topic work will allow to:

- define a parametrizable solution for a ranking model of flight alternatives, and validation logic,
- develop a prototype tool implementing the proposed solution

Expected output is:

- a prototype software engine allowing to trade and rank pilot actions alternatives semi-automatically or automatically.

Main assumption to be considered is that elementary effects of a pilot action on performance items is outside the scope of the present topic. This transfer function modelling highly linked to trajectory predictions will have to be discussed with Topic Manager.

Applicant will contribute to flight policies input data required for this work. These could be either available with the applicant or collected from other sources, in which case, applicant should have means to collect and process those data.

The main activities and deliverables are sketched in the table below, however, applicant are encouraged to propose alternate approach to ensure achievement of the topic objectives.

Tasks		
Ref. No.	Title – Description	Due Date
WP1	Technical resources and problem definition	T1 + 3 months
WP2	Domain driven analysis of multicriteria decision making techniques	T1 + 6 months
WP3	Flight policy data collection from airline operation center	T1 + 9 months
WP4	Crew Assistant Decision Model and validation logic	T1 + 17 months
WP5	Crew Assistant Decision Model verification and validation	T1 + 20 months
WP6	Evolution and update	T1 + 24 months

WP1 : Technical resources and problem definition

The objectives of this work package are to:

- describe technical resources (input data, initial key performance areas modelling including

elementary contributing items, trajectory predictions),

- define technical problem (use cases & functional scope, data to be modelled ,model interface with trajectory predictions functions, modelling technologies),
- define technical requirements (interfaces, accuracy, performance...)

Close interaction with Topic manager is mandatory for this Work Package.

WP2 : Domain driven analysis of multicriteria decision making techniques

The objectives of this work package are to:

- describe candidate multi-criteria decision making techniques, covering at least :
 - outranking methods
 - multi-attribute utility theory
 - analytic hierarchy/network process
 - VIKOR techniques,
- perform a domain driven analysis of the above techniques in view of the problem definition of WP1,
- identify a preferred solution (a single technique or a compound of several ones)
- define and describe corresponding verification and validation approach (scenarii, criteria).

WP3 : Flight policy data collection from an airline

Activities of this work package are:

- establish a flight policy data collection plan encompassing the list of data to be collected,
- define and describe the data processing to be performed on collected data for subsequent use by multi-criteria decision making engine
- provide the processed data to be used as inputs for multicriteria decision making engine.

WP4 : Crew Assistant Decision Model development and validation logic

The objectives of this work package are to:

Step 1:

- define and describe algorithmic solution for ranking alternatives (external interfaces, internal parameters, mathematical relations between external interfaces and internal parameters),
- define and describe verification and validation logic (scenarii, criteria).

Step 2:

- develop software engine prototype by implementing algorithmic solution according to the design established in Step 1,
- document the architectural description of the prototype and usage guidelines

WP5 : Crew Assistant Decision Model verification and validation

The objectives of this work package are to:

- define software engine prototype validation test plan and description of associated tools,
- apply validation test plan and analyse results.

WP6 : Evolution and update

The objective of this work package is to provide a support for possible software engine debugging and/or models and tools evolutions before the delivery of the final version.

3. Major Deliverables/ Milestones and schedule (estimate)

Deliverables			
Ref. No.	Title – Description	Type	Due Date
D1.1	Technical Resources and Problem definition	R	T1 + 3 months
D2.1	Trade-off report on multi-criteria decision making techniques	R	T1 + 6 months
D3.1	Flight policy data collection report	R	T1 + 9 months
D4.1	Crew Assistant Decision model description	R	T1 + 17 months
D4.2	Crew Assistant Decision model software package (first release)	P,R	T1 + 17 months
D5.1	Crew Assistant Decision Model Validation Test Plan and Report	R	T1 + 20 months
D6.1	Crew Assistant Decision model description and software package (final release)	P,R	T1 + 24 months

Milestones (when appropriate)			
Ref. No.	Title – Description	Type	Due Date
M1	Prototype Development Readiness Review		T1 + 10 months
M2	First release Results Review		T1 + 20 months
M3	Final Acceptance		T1 + 24 months

4. Special skills, Capabilities, Certification expected from the Applicant(s)

- Experience and strong background on mathematical multi-criteria decision making modelling techniques is sought. Background in applying these techniques in other transportation domain is a plus.
- Collaboration with airlines is encouraged to collect flight policy data and to validate multi-criteria decision making model against experienced flight preferences.
- Data collection and processing: Capability to collect and process flight policy data.
- Modeling technologies: Knowledge and background in the multicriteria decision making techniques is a prerequisite.
- Trajectory computation and optimization: Background in aircraft trajectory computation and optimization is a nice to have additional feature.

5. Abbreviations

FMS	Flight Management System
WP	Work Package

III. JTI-CS2-2018-CfP09-SYS-01-13: Camera-based smart sensing system for cabin readiness

Type of action (RIA/IA/CSA):		IA	
Programme Area:		SYS	
(CS2 JTP 2015) WP Ref.:		WP 2	
Indicative Funding Topic Value (in k€):		850	
Topic Leader:	Zodiac Engineering	Type of Agreement:	Implementation Agreement
Duration of the action (in Months):	30	Indicative Start Date (at the earliest)⁹¹:	Q3 2019

Topic Identification Code	Title
JTI-CS2-2018-CfP09-SYS-01-13	Camera-based smart sensing system for cabin readiness
Short description	
This topic covers the development and demonstration at TRL5 of a camera-based sensing solution for digitalized on-demand verification of TTL requirements for cabin luggage. In the context of increased datafication of the a/c cabin environment, the solution shall deploy object-recognition algorithms based on artificial intelligence in conjunction with embedded cameras in order to contribute to more efficient a/c cabin operations. Demonstration shall be done as part of the Integrated Cabin Demonstrator of WP 2.4.	

Links to the Clean Sky 2 Programme High-level Objectives ⁹²				
This topic is located in the demonstration area:		Innovative Cabin Passenger/Payload Systems		
The outcome of the project will mainly contribute to the following conceptual aircraft/air transport type as presented in the scene setter:		Advanced Long and Short/Medium Range		
With expected impacts related to the Programme high-level objectives:				
Reducing CO₂ emissions	Reducing NO_x emissions	Reducing Noise emissions	Improving EU Competitiveness	Improving Mobility
<input type="checkbox"/>	<input type="checkbox"/>	<input type="checkbox"/>	<input checked="" type="checkbox"/>	<input checked="" type="checkbox"/>

⁹¹ The start date corresponds to actual start date with all legal documents in place.

⁹² For further info see Chapter 1 "Introduction to the Programme Scene Setter / Objectives" with key technology themes / demonstration areas. Detailed information available in the CS2 Development Plan accessible via the Clean Sky JU Website and EC Participant Portal.



1. Background

This topic contributes to the activities under WP2.2 “Cabin Applications” and WP2.4 “C&C demonstrations” of WP2 “C&C Systems”. The major objectives of WP2.2 are to develop connected cabin technology bricks for enhanced passenger experience, more efficient cabin operations and reduced TAT. As part of WP2.4 “C&C demonstrations” an Integrated Cabin Demonstrator will be set up for TRL5 verification tests of the different technology bricks.

Today’s cabin operations are to a significant extent based on manual processes. This results in an increased workload for the crew, operational inefficiencies and a non-negligible risk of human errors in handling safety-related procedures. For taxi, take-off and landing (TTL) specific cabin readiness requirements apply to the passenger, to the position of seat components and to cabin luggage. In order to obtain gains in efficiency and reliability, datafication of the cabin environment towards eventually a fully connected cabin is on the rise. Current research focuses on the integration of sensors in the cabin environment to monitor specific functions and on the related transmission and exploitation of generated data. A large variety of technology routes are investigated such as SAW sensors, inclinometers, Hall effect sensors or RFID-based solutions.

In addition, the usage of cameras in conjunction with object-recognition algorithms based on artificial intelligence (AI) may offer a promising complementary solution for specific functionalities such as cabin luggage detection. AI refers in general to a programme aiming to understand and reproduce human cognition. In recent years it has strongly gained momentum, and within the present topic it is referred to one of its multiple expressions which is machine learning. The latter expression is considered today as the fastest developing one and the most subject to global competition. The rapid growth of available data in conjunction with increased data management capabilities and tailor-made algorithms lead to various applications in industrial sectors such as transport where driverless cars rely among others on AI cameras inside and outside of the vehicle.

In the aircraft cabin environment, cameras are used as of today for overall cabin monitoring (CVMS) purposes. CVMS are characterized by restrained video and image analysis capabilities and are not conceived for specific purposes such as cabin readiness verification. Camera-based smart sensing systems for cabin readiness are required to have precise object-recognition capabilities on individual seat level by complying to stringent constraints related to airworthiness certification, low weight and competitive cost level.

2. Scope of work

This topic covers the development and demonstration at TRL5 of a camera-based sensing solution for digitalized on-demand verification of TTL requirements for cabin luggage. Figure 1 gives a schematic overview of the requirements. It is required to detect cabin luggage position on individual a/c seat level and to report non-conformity to TTL requirements via wireless data transmission. The developed solution composed of the camera hardware, associated data management equipment and object-recognition software shall be demonstrated at TRL5 as part of the Integrated Cabin Demonstrator of WP2.4.

Multiple objects detection and localization capabilities are to be developed for clear distinction of cabin luggage. Training and validation of the algorithm is done via suitable datasets provided by the applicant. Cameras are designed and engineered to respond to stringent cost and weight constraints. Image data processing is to be integrated in the Cabin Management System for display of the TTL conformity report

on the crew panel. A final prototype is delivered for a single 6-abreast narrow-body aircraft seat row.

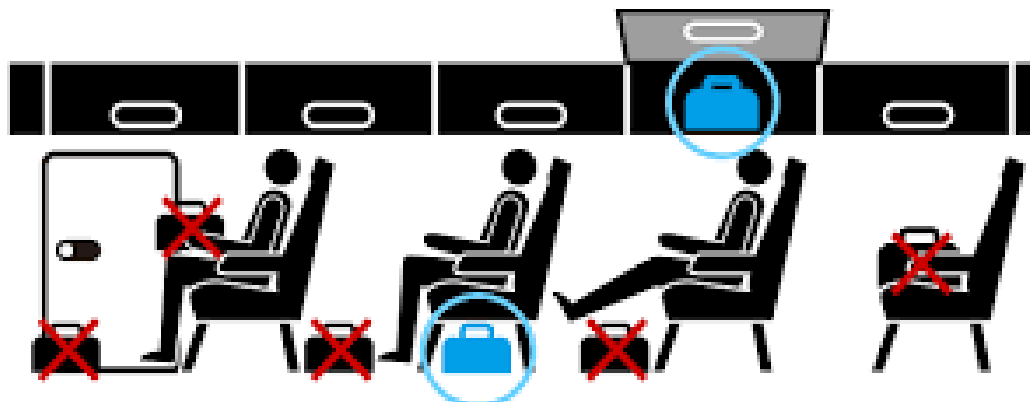

Figure 1 : TTL requirements for cabin luggage

Tasks		
Ref. No.	Title - Description	Due Date
T1	Definition of interfaces and requirements, regulatory compliance analysis	T0 + 4
T2	Selection of AI-camera technologies	T0 + 7
T3	Preliminary system design	T0 + 12
T4	TRL4 system review	T0 + 18
T5	TRL5 Demonstration in WP2.4 Integrated Cabin Demonstrator	T0 + 30

- Task 1: Together with the Topic Manager, the interfaces with the a/c cabin environment for data transmission and processing shall be defined. Requirements in terms of object-recognition capabilities, physical integration in the cabin, airworthiness certification as well as weight and cost constraints shall be detailed. A thorough regulatory compliance analysis shall be conducted on personal data protection and privacy. A TRL plan shall be defined.
- Task 2: Based on the interfaces and requirements defined in Task 1, a thorough technology scouting shall be conducted. The most appropriate AI-camera solution shall be identified for validation by the Topic Manager within a technology selection review, based on a detailed presentation of strengths & weaknesses of the most promising solutions considered.
- Task 3: The preliminary design of the system shall be elaborated based on the outcome of Tasks 1 and 2 and a preliminary design review organised for validation. Special attention shall be given to a clear presentation of the system architecture and the functioning principles of the proposed machine learning algorithms.
- Task 4: According to the TRL plan defined in Task1, the system shall be further developed to a TRL4 and a dedicated TRL4 system review shall be organized.
- Task 5: The final prototype for a single 6-abreast narrow-body aircraft seat row shall be validated for subsequent integration into the WP2.4 Cabin Demonstrator. A TRL5 test protocol shall be established together with the Topic Manager. Demonstration tests shall be conducted and results reported in the TRL5 System Demonstration Report.

3. Major Deliverables/ Milestones and schedule (estimate)

*Type: R=Report, D=Data, HW=Hardware

Deliverables			
Ref. No.	Title - Description	Type*	Due Date
D1	Interfaces & requirements specification	R	T0 + 4
D2	Report on AI-camera technology scouting	R	T0 + 7
D3	Preliminary Design Review	R	T0 + 12
D4	TRL4 system review	R	T0 + 18
D4	Final prototype for Cabin Demonstrator integration	HW	T0 + 24
D5	TRL5 System Demonstration Report	R	T0 + 30

Milestones (when appropriate)			
Ref. No.	Title - Description	Type*	Due Date
M1	Requirements specification	R	T0 + 4
M2	Technology selection	R	T0 + 7
M3	TRL4 achievement	R	T0 + 18
M4	Demonstration test completion	R	T0 + 30

Task / Month	1	2	3	4	5	6	7	8	9	10	11	12	13	14	15	16	17	18	19	20	21	22	23	24	25	26	27	28	29	30
T1 Definition of interfaces and requirements, regulatory compliance analysis	■	■	■	■																										
T2 Selection of AI-camera technologies					■	■	■	■																						
T3 Preliminary system design								■	■	■	■	■																		
T4 TRL4 system review													■	■	■	■	■	■												
T5 TRL5 Demonstration in WP2.4 Integrated Cabin Demonstrator																					■	■	■	■	■	■	■	■	■	■

4. Special skills, Capabilities, Certification expected from the Applicant(s)

- The applicant shall have large experience and proven competencies in developing tailor-made object-recognition algorithms based on AI.
- The applicant shall have large experience and proven competencies in developing embedded camera systems and related video data processing.
- The applicant shall have large experience and proven competencies in developing machine learning techniques.

5. Abbreviations

AI	Artificial Intelligence
C&C	Cabin & Cargo
CVMS	Cabin Video Monitoring System
RFID	Radio-Frequency Identification
SAW	Surface acoustic wave
TAT	Turnaround time
TTL	Taxi Take-off Landing

IV. JTI-CS2-2018-CfP09-SYS-01-14: Multi-Material Thermoplastic high pressure Nitrogen Tanks for Aircraft

Type of action (RIA/IA/CSA):		IA	
Programme Area:		SYS	
(CS2 JTP 2015) WP Ref.:		WP 2.3	
Indicative Funding Topic Value (in k€):		650	
Topic Leader:	Diehl Aviation	Type of Agreement:	Implementation Agreement
Duration of the action (in Months):	24	Indicative Start Date (at the earliest)⁹³:	Q3 2019

Topic Identification Code	Title
JTI-CS2-2018-CfP09-SYS-01-14	Multi-Material Thermoplastic high pressure Nitrogen Tanks for Aircraft
Short description	
Employing fiber reinforced thermoplastics bears the potential to reduce manufacturing costs and to enhance performance of high pressure airborne gas tanks compared to state of the art components. To fully exploit this potential, a combination of different materials in one tank shell forming a Multi-Material Tank (MMT) is required. However, appropriate material combinations must be selected and processes for MMT shall be developed.	

Links to the Clean Sky 2 Programme High-level Objectives⁹⁴				
This topic is located in the demonstration area:		Innovative Cabin Passenger/Payload Systems		
The outcome of the project will mainly contribute to the following conceptual aircraft/air transport type as presented in the scene setter:		Advanced Long and Short/Medium Range		
With expected impacts related to the Programme high-level objectives:				
Reducing CO₂ emissions	Reducing NO_x emissions	Reducing Noise emissions	Improving EU Competitiveness	Improving Mobility
<input type="checkbox"/>	<input type="checkbox"/>	<input type="checkbox"/>	<input checked="" type="checkbox"/>	<input type="checkbox"/>

⁹³ The start date corresponds to actual start date with all legal documents in place.

⁹⁴ For further info see Chapter 1 "Introduction to the Programme Scene Setter / Objectives" with key technology themes / demonstration areas. Detailed information available in the CS2 Development Plan accessible via the Clean Sky JU Website and EC Participant Portal.



1. Background

Within CS2-SYS-ITD - Cabin and Cargo Systems a novel halon-free fire extinguishing system employing water-mist and nitrogen is being developed. The system requires high pressure tanks for storage of nitrogen. These tanks must fulfill various technical requirements e.g. very low permeation of gases, mechanical loads according to RTCA Do160 Rec. G, survival of high temperatures, large temperature gradients, as well as resistance against various chemical media. At the same time lightweight materials and lightweight designs as well as economic manufacturing process are required for these components. Currently lightweight pressure vessels or tanks, which are used for storage of compressed natural gas (CNG) or hydrogen, mainly in automotive applications, are composed of either a metallic or thermoplastic liner on the inside and a fiber reinforcement on the outside. The liner is required to prevent permeation of gases through the tank shell. The outer reinforcement, which is typically made of glass or carbon fiber and a thermoset matrix ensures the mechanical integrity. State of the art vessels with polymer liners only have to store CNG or hydrogen for a very limited time, compared to the storage time that is required for a fire suppression system in passenger aircrafts. Therefore, current tanks would either not fulfill longterm permeation requirements or they are thick-walled parts, which exceed weight limitations. Furthermore, state of the art liners from automotive applications made from PA 6 may not form permanent bonds with the thermoset fiber reinforcement. This may result in the detachment of the liner from the fiber reinforcement during fast expansion of the stored nitrogen.

Therefore, a novel concept for airborne pressure vessels, including new material combinations and an innovative manufacturing concept shall be developed.

A combination of different thermoplastic materials shall be employed for manufacturing of a multi-layer tank shell. The advantages of thermoplastic materials compared to thermoset matrix materials are reduced cycle times during manufacturing. In addition, high performance thermoplastic materials can sustain higher temperatures than typical thermosets and they show good resistance against a variety of chemical media. The combination of different thermoplastics in a Multi-Material Tank (MMT) shell allows to make best use of the specific properties of different thermoplastic materials. The principle of combining different materials, each fulfilling different requirements, has for example successfully been used in multi-layer packagings for food.

2. Scope of work

In order to fulfill the various requirements of an airborne pressure vessel for longterm storage of nitrogen, a combination of different materials shall be employed to develop novel MMT. The project addresses three major challenges on the way towards MMT: the selection of appropriate materials and material combinations, the development of an appropriate manufacturing process chain and the design of airborne pressure vessels making use of multi material shells.

The first step in the development of the MMT is to analyze the requirements of the nitrogen tank and to identify appropriate thermoplastic materials which comply best with the specified requirements. At least one layer of the tank must prevent permeation of nitrogen to ensure a long service life. A second material may be employed to protect the tank against mechanical impacts. Finally, a third thermoplastic matrix material for the CFRP shell must be selected which has a good thermal stability and good fire-smoke-toxicity (FST) properties. In addition to fulfilling these functional requirements, the different thermoplastics must be chemically compatible with each other in such a way, that they form molecular bonds during the manufacturing process. Completely new combinations of polymers might be required and their compatibility must be demonstrated by appropriate tests. Therefore, the material selection process will demand profound knowledge in material science of polymers.

In addition to the selection of suitable and compatible materials, appropriate processes for the

manufacturing of multi-layer liners as well as the application of the fiber reinforcement must be selected and developed. A combination of processes such as co-extrusion of thermoplastic films, thermoforming and laser-assisted fiber placement seems appropriate for this task. Combining various thermoplastics in one manufacturing process is very challenging due to large differences in e.g. melting temperature, viscosity of polymer melts, thermal stability etc.. Especially producing complex-shaped and thin-walled parts - such as tanks - out of multi-matrix materials, demands innovative solutions. Hence, appropriate manufacturing technologies must be selected, an innovative process chain must be developed and suitable process parameters must be identified.

Eventually, a pressure vessel shall be designed exploiting the possibilities of the developed material combinations and manufacturing techniques. The vessel shall outperform state of the art tanks in terms of longterm permeation performance and and lightweight design.

The specific tasks are described in the following paragraphs:

Tasks		
Ref. No.	Title – Description	Due Date
Task 1	Definition and clarification of requirements, boundary conditions and testing procedures.	T0+3
Task 2	Selection of appropriate thermoplastic materials and selection of manufacturing technologies / process chain	T0+7
Task 3	Development of manufacturing process	T0+12
Task 4	Manufacturing of specimens	T0+15
Task 5	Testing of specimens under different environmental conditions	T0+18
Task 6	Design of demonstrator and toolings	T0+20
Task 7	Manufacturing of tank demonstrator	T0+24

- Task 1: The requirements of the envisaged MMT shall be defined and clarified in close collaboration between the applicant and the Topic Leader. The requirements comprise functional requirements that are inherent to the high pressure nitrogen tank, as well as mechanical requirements that origin from certification aspects described in “Environmental Conditions and Test Procedures for Airborne Equipment (RTCA) DO-160”. The required tests shall be executed with samples that will be manufactured in Task 4 and with the demonstrators that will be manufactured in Task 7.
- Task 2: Based on the requirements defined in Task 1, a comprehensive study on different thermoplastic materials shall be conducted. The objective of this study is to identify the most appropriate materials that fulfil the specific requirements of the tank and to make best use of the MMT concept. Also aspects of material availability, processability in specific manufacturing processes and chemical compatibility of the different thermoplastics shall be considered.
- In parallel, a process chain, defining the required manufacturing technologies for manufacturing MMT shall be developed. If required, semi-finished parts such as thermoplastic films should be defined at this stage. The task is completed when materials, semi-finished parts, possible suppliers and a complete process chain have been defined.
- Task 3: The Task is dedicated to the development and adaption of the innovative manufacturing technologies for MMT. This task comprises the manufacturing process of a dedicated liner (if required) as well the process for adding the CFRP layers. Depending on the specific process chain that was developed in Task 1, different process technologies might have to be further developed

simultaneously. The task may also include the adaption of hardware to the specific requirements of the project.

- Task 4: Multi-Material samples shall be manufactured. The samples shall be suitable to evaluate bond-strength between Multi-Material surfaces. In addition, samples shall be manufactured for determining standard material properties at different environmental conditions (see Task 5). To benchmark novel Multi-Material samples against state of the art materials, also standard epoxy specimens need to be manufactured.
- Task 5: Tests for the evaluation of bond strength between non-homogenous materials that have been selected shall be executed. In addition, standard material properties at temperatures between +200°C and at least -55°C (ideally -150°C) shall be determined for Multi-Material samples and standard thermoset materials, e.g. epoxy laminates from state of the art lightweight vessels.
- The standard material properties of thermoplastic Multi-Material samples shall be benchmarked against standard thermoset material's properties. Standard material properties shall be determined in accordance with typical testing standards for anisotropic materials. Test, rResults of the benchmark study will have to be summarized in a benchmark study in and a detailed test report.
- Task 6: In close collaboration with the Topic Leader the tank demonstrator (approximately 200 - 400 bar pressure and 25 - 150 l capacity) shall be defined. Required toolings for the selected manufacturing technologies (defined in Task 2) shall be designed and procured. The detailed dimension and required pressure will be jointly defined by the applicant and the Topic Leader in Task 1.
- Task 7: The developed process chain shall be demonstrated by manufacturing a Multi-Material Tank employing the selected materials. The tank shall meet the requirements specified in Task 1. The Technology Readiness Level (TRL) shall be evaluated in a TRL review together with the Topic Leader.

3. Major Deliverables/ Milestones and schedule

*Type: R=Report, D=Data, HW=Hardware

Deliverables			
Ref. No.	Title – Description	Type*	Due Date
D1	Pressure Vessel Specification document	R	T0+3
D2	Study on selected materials: theoretical background on compatibility and manufacturing process chain definition for selected materials	R	T0+12
D3	Test and manufacturing report: results of mechanical tests, manufacturing process description incl. process parameters, employed equipment and materials	R	T0+18
D4	Tank demonstrator(s)	HW	T0+24

Milestones			
Ref. No.	Title – Description	Type*	Due Date
M1	Definition of requirements completed	R	T0+3
M2	Material selection and procurement completed. Process technologies have been defined	R	T0+7
M3	Manufacturing process specified and process parameter specification completed	R	T0+12
M4	Manufacturing of required specimens completed	R	T0+15

Milestones			
Ref. No.	Title – Description	Type*	Due Date
M5	Testing of specimens under different environmental conditions completed	R	T0+18
M6	Review of demonstrator design and drawings	R	T0+16
M7	Manufacturing of tank demonstrator	HW	T0+24

Gantt Chart for Deliverables and Milestones:

Month	1	2	3	4	5	6	7	8	9	10	11	12	13	14	15	16	17	18	19	20	21	22	23	24
T1 Definition and clarification of requirements, boundary conditions and testing procedures.			D1 M1																					
T2 Selection of appropriate thermoplastic materials and selection of manufacturing technologies / process chain							M2																	
T3 Development of manufacturing process												D2 M3												
T4 Manufacturing of specimens															M4									
T5 Testing of specimens under different environmental conditions																		D3 M5						
T6 Design of demonstrator and toolings																M6								
T7 Manufacturing of tank demonstrator																							D4 M7	

4. Special skills, Capabilities, Certification expected from the Applicant(s)

- The applicant shall have a good track record in manufacturing of complex CFRP parts such as pressure vessels and tanks ideally with thermoplastic materials
- Profound knowledge in thermoplastic materials and multi-material applications such as co-extrusion
- The applicant shall be experienced in appropriate reinforcement process such as automated fiber placement
- The applicant shall be experienced in the design of pressure-vessels
- Access to the required manufacturing facilities (e.g. thermoplastic fiber placement facilities, thermoforming) that are required to manufacture the described specimens and samples
- Access to the required testing facilities for mechanical tests in a wide temperature range (ideally between -150°C and +200°C) and the capability to perform typical standardized tests according to ASTM or EN ISO standards with anisotropic fiber reinforced materials.

5. Abbreviations

CFRP	Carbon Fiber reinforced Plastics
CNG	Compressed Natural Gas
FST	Fire-Smoke-Toxicity
MMT	Multi-Material Tank
RTCA Do160 Rec. G	Environmental Conditions and Test Procedures for Airborne Equipment Do-160
TRL	Technology Readiness Level

V. JTI-CS2-2018-CfP09-SYS-02-56: Additive Manufacturing Magnetic Motor

Type of action (RIA/IA/CSA):		IA	
Programme Area:		SYS	
(CS2 JTP 2015) WP Ref.:		WP 3.2.5	
Indicative Funding Topic Value (in k€):		700	
Topic Leader:	SAFRAN	Type of Agreement:	Implementation Agreement
Duration of the action (in Months):	24	Indicative Start Date (at the earliest)⁹⁵:	Q3 2019

Topic Identification Code	Title
JTI-CS2-2018-CfP09-SYS-02-56	Additive Manufacturing Magnetic Motor
Short description	
<p>The active inceptor ergonomic performance is reached thanks to direct drive configuration, using electrical torque motor. The associated motor weight is a significant part of the inceptor total weight. The goal of the project is to investigate additive manufacturing technology to design and, manufacture a new generation of electrical motors, mixing all materials, especially for magnetic aspects, and to evaluate savings on weight, cost and performances, compare to current state of the art in traditional design and manufacturing.</p>	

Links to the Clean Sky 2 Programme High-level Objectives⁹⁶				
This topic is located in the demonstration area:		Next-Generation Civil Tilt Rotor		
The outcome of the project will mainly contribute to the following conceptual aircraft/air transport type as presented in the scene setter:		Next-Generation Tilt Rotor		
With expected impacts related to the Programme high-level objectives:				
Reducing CO₂ emissions	Reducing NO_x emissions	Reducing Noise emissions	Improving EU Competitiveness	Improving Mobility
<input checked="" type="checkbox"/>	<input type="checkbox"/>	<input type="checkbox"/>	<input checked="" type="checkbox"/>	<input type="checkbox"/>

⁹⁵ The start date corresponds to actual start date with all legal documents in place.

⁹⁶ For further info see Chapter 1 "Introduction to the Programme Scene Setter / Objectives" with key technology themes / demonstration areas. Detailed information available in the CS2 Development Plan accessible via the Clean Sky JU Website and EC Participant Portal.

1. Background

The activity of WP 3.2.5 Smart Active Inceptors for Tilt Rotor demonstration is a part of the SYS WP 3 Innovative Electric Wing.

Flight Controls for Tilt Rotor have a high level of complexity due to aircraft architecture (midway between A/C and H/C). Active inceptor is a mean to improve flight information shared between pilots and FCCs, and by this way improve safety during flight.

The Objective of the WP is to develop an innovative Cockpit control system with the integration of Smart & Active Inceptors.

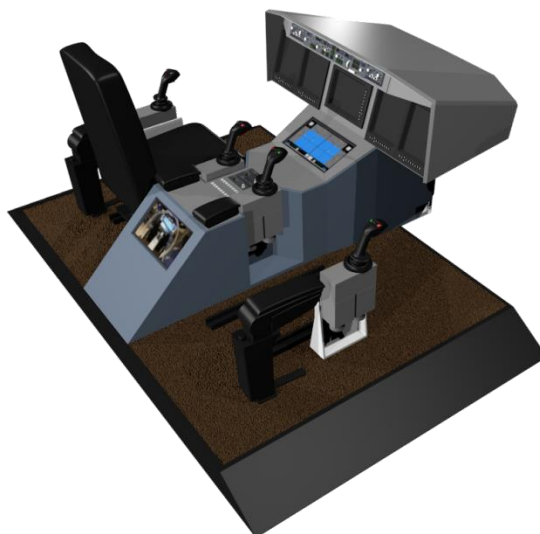

Innovative cockpit example

With the progressive disappearance of mechanical links between aerodynamic control surfaces and piloting inceptor devices and the wide use of FlyByWire, the image of the aircraft behavior is no longer provided to pilots by passive inceptor devices only. The development of active inceptor allows giving pilots a direct feeling of the aircraft behavior, in particular flight limitations or control surface positions.

Our solution provides a high level of performances with differentiating ergonomics and carries out to improve handling qualities. This ergonomics is made possible thanks to direct drive architecture. With this architecture motor providing force feel is directly linked with grip. Due to this architecture, motors are main contributors for weight and power consumption. Optimize performances of current motor, in terms of weight, power consumption and torque is the main challenge.

Additive Manufacturing is a promising technology that may allow improving motor performances, as it enables realizing complex shapes of the magnetic components, compact motor design and innovative mechanical assembly of spare parts. This however, requires dedicated study to find the optimal balance between more performing motor topologies and affordability of their realization.

The proposed work aims at improving motor performances (e.g. weight, power consumption, torque, energy density and compactness of the design) through new motor design approaches made possible by the use of additive manufacturing technology, taking into account safety constraints.

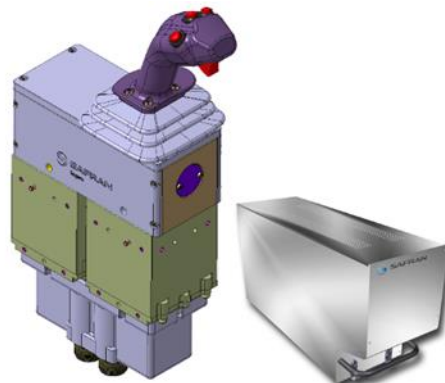

Smart Active Inceptor

Description of activities

This topic includes:

a) Expected performances

The motor expected is a single-phase motor, with limited stroke.

The main characteristics are listed hereafter:

- Functional envelop : 100mmX100mmX100mm
- Max Weight : 3 kg
- Torque available on all stroke : 8.0 N.m
- Effective stroke : 70° mini
- Max Power consumption : 150W (for max torque with no motion : zero speed)

The torque expected (8 N.m) should be available at least on 70° angulare displacement.

b) Topological optimization study

- Magnetic study
 - Modelling
 - Simulation
- Topological optimization
 - Definition of boundary conditions
 - Interfaces
 - Load paths
 - Optimization calculation
- Design
 - 3D modelling
 - Detailed Drawings
- Safety analysis
- Manufacturing consideration
 - Additive manufacturing approach
 - Traditional manufacturing approach
 - Hybrid (additive + traditional) manufacturing

c) Mock-up for test evaluation

- Prototype manufacturing
- Evaluation
 - Functional tests

- Performance tests

2. Scope of work

Tasks		
Ref. No.	Title - Description	Due Date
T1	Magnetic study	T0+4 months
T2	Topologic optimisation	T0+8 months
T3	Design phase	T0+12 months
T4	Manufacturing	T0+18 months
T5	Evaluation	T0+24 months

3. Major Deliverables/ Milestones and schedule (estimate)

*Type: R=Report, D=Data, HW=Hardware

Deliverables			
Ref. No.	Title - Description	Type*	Due Date
D1	Magnetic study report → Calculation justification for magnetic sizing	R	T0+4 months
D2	Topologic optimisation Report → Calculation and analysis	R	T0+8 months
D3	Definition File → 3D + drawings	R	T0+12 months
D4	Functional and performance Evaluation Report	R	T0+24 months
D5	3 motors (1 shipset + 1 spare)	HW	T0+24 months

Milestones (when appropriate)			
Ref. No.	Title - Description	Type*	Due Date
M1	Preliminary Design Review: The main objective of M1 is to validate the pre sizing	D	T0+8months
M2	Design Review: The main objective of M2 is to validate the design to produce	D	T0+12 months
M3	Manufacturing Review: The main objective of M3 is to validate the solution produced according to design definition	D	T0+18 months
M4	Evaluation Review: The main objective of M4 is to validate motor functionalities and performances	R	T0+24months

4. Special skills, Capabilities, Certification expected from the Applicant(s)

- Knowledge on topology optimization of electric motors
- Knowledge on additive manufacturing, using also magnetic materials
- Knowledge on traditional manufacturing of electric motors and its components
- Knowledge on Flight Control System environments would be appreciated



5. Abbreviations

JDP	Joint Development Phase
QTR	Qualification Test Report

VI. JTI-CS2-2018-CfP09-SYS-02-57: Complex cores for CFRP primary structural products manufactured with high pressure RTM

Type of action (RIA/IA/CSA):		IA	
Programme Area:		SYS	
(CS2 JTP 2015) WP Ref.:		WP 4.2	
Indicative Funding Topic Value (in k€):		500	
Topic Leader:	Fokker	Type of Agreement:	Implementation Agreement
Duration of the action (in Months):	18	Indicative Start Date (at the earliest)⁹⁷:	Q3 2019

Topic Identification Code	Title
JTI-CS2-2018-CfP09-SYS-02-57	Complex cores for CFRP primary structural products manufactured with high pressure RTM
Short description	
For complex shaped primary structural CFRP components, multi-part metal core tools are used due to non-releasable areas in the product. The topic aims to develop innovative core tools (using for instance elastomers or shape memory polymers) for these type of products and validate that the process parameters associated to RTM injection will not compromise the cured product quality (compared to products using metal cores), without incurring a large penalty in component weight and cost.	

Links to the Clean Sky 2 Programme High-level Objectives⁹⁸				
This topic is located in the demonstration area:		Enabling technologies		
The outcome of the project will mainly contribute to the following conceptual aircraft/air transport type as presented in the scene setter:		Enabling technologies		
With expected impacts related to the Programme high-level objectives:				
Reducing CO₂ emissions	Reducing NO_x emissions	Reducing Noise emissions	Improving EU Competitiveness	Improving Mobility
<input type="checkbox"/>	<input type="checkbox"/>	<input type="checkbox"/>	<input checked="" type="checkbox"/>	<input type="checkbox"/>

⁹⁷ The start date corresponds to actual start date with all legal documents in place.

⁹⁸ For further info see Chapter 1 “Introduction to the Programme Scene Setter / Objectives” with key technology themes / demonstration areas. Detailed information available in the CS2 Development Plan accessible via the Clean Sky JU Website and EC Participant Portal.

1. Background

Over the years, aircraft have become more light weight, thereby saving fuel and costs and increasing performance, range and capacity. The application of composites has been a great contributor to these more light weight structures. Landing Gear Parts however, being a load carrying and flight critical system conventionally are made from metal, such as aluminium, titanium and/or ultra-high strength steel. Within the WP4.2 and WP4.3 work packages of the Systems ITD, the HECOLAG project (High Efficiency Composite Landing Gear) will develop highly efficient composite landing gear parts, both for large aircraft nose landing gear and helicopter landing gears. Primary goals are the development and demonstration of advanced structural concepts, highly automated production technologies to reduce weight and cost, and a certification strategy that is suited to the use of composite materials in landing gear structures.

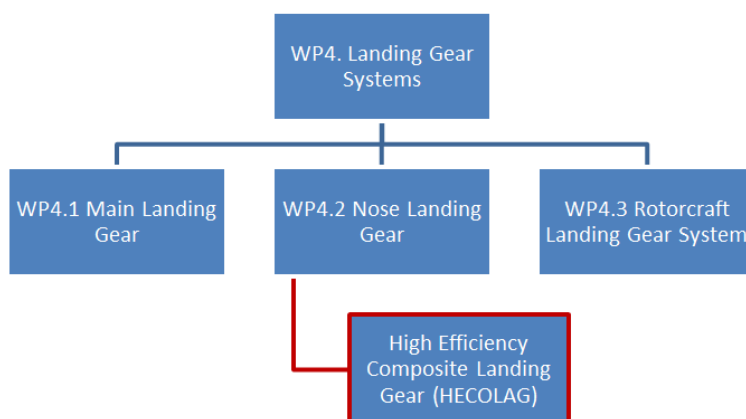

As the technical feasibility of composite materials in critical landing gear structures has been proven over the last decade, the current challenge is to achieve to not only higher weight and cost efficiency, but also larger product sizes and more complex shapes. Since the use of high-pressure resin injection manufacturing technologies or resin transfer moulding (RTM) is key to achieving the required quality and affordability, more complex shapes also result in more complex tools. High structural efficiency is often achieved by using internal product cavities (hollow shapes), since these provide a high stability (buckling and crippling) for a given weight. The product cavity must be filled with an internal tool during resin injection that needs to be removed afterwards. This may only be possible using internal tools that are split in many different parts, which are laborious to clean, install and extract. Alternatively, foam materials may be used but their lower material stiffness (than metal) result in modified injection process parameters and potentially lower quality laminates, while quality checks (using ultrasonic inspection) becomes more complex.



The limitations of the described internal tooling methods negatively affect the commercial viability of a technology that could otherwise lead to substantial weight savings. Therefore, new and innovative



internal tooling methods are needed that use new materials (such as elastomers and shape memory polymers), likely in combination with traditional metal materials, to enable high quality and affordable internal tools suitable for use in high pressure RTM processes. These internal tools should preferably also have the possibility to incorporate heating and/or cooling elements to enable high heat up and cool down rates. These internal tools should enable lower cost manufacturing processes by using less energy and shorter processing cycles while providing a much higher design flexibility.

2. Scope of work

In close collaboration with the HECOLAG partners, the applicant shall develop new or improved core tooling concepts (including materials and processes) for large (up to 2x0.75m) RTM products containing internal cavities. The innovative cores shall be able to withstand high injection pressures (up to 20 bars), operate in industrial manufacturing environments with manufacturing rates of up to 500 parts/year. The innovative tooling shall allow achieving significant reduction of energy consumption, reduced labour cost, allow for ultrasonic inspection, design flexibility. Target applications are large CFRP components (with associated low CTE).

The proposed innovative core concept shall be demonstrated on a composite landing gear component developed within the HECOLAG project. This will be a complex shape, hollow CFRP part with an approximate size of 1900x500x200mm (full specifications will be provided after partner selection). The benefits and performance of the new tooling concept will be compared to the baseline (multi-part metal) tool developed within the HECOLAG project.

Tasks		
Ref. No.	Title - Description	Due Date
T1	Requirements synthesis and core concept generation	T0+3M
T2	RTM core design and potentially development testing	T0+12M
T3	RTM core manufacturing	T0+15M
T4	RTM core test and demonstration	T0+17M
T5	Test and demonstration reporting	T0+18M

Improved RTM core concepts and materials shall be identified and described, based on geometric and process requirements defined by the Topic Manager. The aim of the improved concepts and materials is to reduce product-manufacturing cost and increase design flexibility, while still being suitable to aerospace production environments and quality requirements.

Successively a detailed design of the selected concept shall be worked out. This may encompass material testing (to verify material suitability to process parameters) and execution of relevant analyses, such as thermal aspects and deformation. The Topic Manager will contribute to the design phase and provide requirements and key design parameters for the development (e.g. product shape and geometry, process boundaries and product material types).

The participant shall manufacture the RTM core design and perform all relevant testing and verifications (geometry checks, tool release, thermal surveys, pressure/vacuum checks), using the outer RTM tool that will be provided by the Topic Manager (for the duration of the testing phase).

Finally, the RTM core shall be used to manufacture one (or more) demonstration products with a view

to validate the performance of the innovative core. The Topic manager will provide the dry fibre preform to be used as well as the process specifications.

The applicant shall elaborate on the results of the checks and demonstration of the RTM core, as well as on the comparison with the baseline (metal) tool.

3. Major Deliverables/ Milestones and schedule (estimate)

*Type: R=Report, D=Data, HW=Hardware

Deliverables			
Ref. No.	Title - Description	Type*	Due Date
D1	Improved RTM core concept description	R	T0+3M
D2	RTM core technical data package containing design description, mechanical and thermal analysis results, materials description	R	T0+12M
D3	RTM core test and verification report	R	T0+18M

Milestones (when appropriate)			
Ref. No.	Title - Description	Type*	Due Date
M1	RTM core design completed		T0+12M
M2	Final reporting completed		T0+18M

4. Special skills, Capabilities, Certification expected from the Applicant(s)

- Knowledge of aerospace products, development, quality requirements.
- Experience in the development of core tools for RTM, including the use of composite tool materials (such as elastomers or shape memory polymers), experience with integrated heating/cooling methods will be beneficial.

5. Abbreviations

CFRP	Carbon Fibre Reinforced Plastic
CS25	Certification Specification of large aeroplanes (EASA)
CSJU	Clean Sky Joint Undertaking
CTE	Coefficient of Thermal Expansion
HECOLAG	High Efficiency Composite Landing Gear
ITD	Integrated Technology Demonstrators
RTM	Resin Transfer Moulding
WP	Work Package

VII. JTI-CS2-2018-CfP09-SYS-03-19: Flexible and Automated Manufacturing of wound components for high reliability

Type of action (RIA/IA/CSA):		RIA	
Programme Area:		SYS	
(CS2 JTP 2015) WP Ref.:		WP 100.1	
Indicative Funding Topic Value (in k€):		1100	
Topic Leader:	University of Nottingham	Type of Agreement:	Implementation Agreement
Duration of the action (in Months):	24	Indicative Start Date (at the earliest)⁹⁹:	Q3 2019

Topic Identification Code	Title
JTI-CS2-2018-CfP09-SYS-03-19	Flexible and Automated Manufacturing of wound components for high reliability
Short description	
High reliability and power dense aerospace electromagnetic components require alternative coil winding manufacturing processes, which can deliver compact windings with high dimensional tolerances, high space fill factor and low losses. The scope of this CFP is to develop and deliver an innovative and flexible coil fabrication system, which can provide programmable 3D formed coil shapes suitable for high frequency operation and effective coil insertion and welding strategies for aerospace wound components.	

Links to the Clean Sky 2 Programme High-level Objectives¹⁰⁰				
This topic is located in the demonstration area:		Electrical systems		
The outcome of the project will mainly contribute to the following conceptual aircraft/air transport type as presented in the scene setter:		Advanced Long and Short/Medium Range		
With expected impacts related to the Programme high-level objectives:				
Reducing CO₂ emissions	Reducing NO_x emissions	Reducing Noise emissions	Improving EU Competitiveness	Improving Mobility
<input checked="" type="checkbox"/>	<input type="checkbox"/>	<input type="checkbox"/>	<input checked="" type="checkbox"/>	<input type="checkbox"/>

⁹⁹ The start date corresponds to actual start date with all legal documents in place.

¹⁰⁰ For further info see Chapter 1 "Introduction to the Programme Scene Setter / Objectives" with key technology themes / demonstration areas. Detailed information available in the CS2 Development Plan accessible via the Clean Sky JU Website and EC Participant Portal.



1. Background

Fast switching, wide-bandgap devices such as SiC are enabling higher fundamental operating frequencies leading to smaller electrical machines and passive magnetic components. This however results in a number of challenges namely; higher AC losses in windings, faster degradation of coil insulation and greater susceptibility to EMI. Coils are often required to be multi stranded and interleaved to reduce AC losses and with appropriate insulation to withstand the fast switching edges. This in turn tends to lead to poor overall fill factors, large end windings, higher composite coil thermal resistance, higher losses and higher likelihood of winding failure. New coil forming methodologies and fabrication techniques are required to mitigate these.

Such improvements in coil winding in electrical motors, generators and other wound components will be a key enabling technology to make these components more reliable and power dense. This requires a paradigm shift from how windings are manufactured today where in many instances are manually wound with relatively poor fill factors and poor repeatability. Whilst techniques such as hairpin windings have been developed these are often limited to solid bar conductors resulting in high AC losses and with limited flexibility to cater for aerospace production requirements. The scope of this work is to develop novel methodologies and hardware which is able to programme and form 3D coils and automatically join them through laser welding (or other means) to form a complete winding system. In order to achieve this a number of challenges will need to be first understood and then overcome.

Within SYS WP 100.1 the topic manager is developing a number of actuators and aircraft generators which aim to deliver high power densities and reliability. The windings currently are a main bottle-neck for improved performance due to their maximum temperature constraints which adversely affects power density and reliability. Another constraining aspect is the desire to operate these at high fundamental frequencies (>1kHz) to take advantage of wide-bandgap semiconductors and potentially reduce the size and weight of the magnetic components. This however typically requires multi-stranded coils with small cross-sectional areas or litz-wire which negatively impact fill factor and equivalent slot thermal conductivity.

The successful partner will work with the topic manager to identify the optimum designs of AC winding systems, which are able of minimising AC losses; withstand high dv/dt switching, compacted for a high slot fill factor and able to be automatically formed to high dimensional tolerances. The successful partner will look at the development of a flexible and automated manufacturing coil setup able to shape coils to pre-determined 3D geometries to maximise fill factor, minimise AC losses and to reliably join coils (with multi-stranded wires) to complete the manufacture of stator windings. Whilst the setup will be fully flexible to accommodate the development of different windings for different applications a specific use case will be developed with the topic manager for technical demonstration.

The technical demonstrator is an electrical machine stator with an approximate axial length of 25cm and outer diameter of 20cm. Operating frequency is expected to be in the range of 1.6kHz.

The proposed programme of work should aim to address the following:

- (a) Fully programmable coil forming setup to high tolerance (~0.1mm)
- (b) High fill factors for reduced DC resistance and good thermal conductivity
- (c) Short end-windings for better power density and lower losses
- (d) Defined end geometries for improved cooling methodologies

- (e) Use of Stranded, Laminated and/or Roebel Bars for reduction of AC losses
- (f) Reliable welding method for joining of coils into a complete winding.
- (g) Suitable automatic manufacturing for repeatable results

2. Scope of work

Work Package	Title	Description	Due date
WP0	Coordination and Management	Project management, liaison with topic manager, risk management, dissemination and publication management.	T0+24
WP1	Review and assessment of automated coil forming methods.	Identify and evaluate innovative high precision coil forming technologies and methodologies such as hair-pin technology. To consider how the enamelled wire is aligned, stripped of its insulation, formed and insertion tips produced. Compare technologies in terms of number of joints, ability to reduce AC losses through adoption of litz/laminated/Roebel conductors. Assess and down select technologies against project aims.	T0+3
WP2	Development of the coil forming process and develop a programmable forming tool.	This work package will follow on from WP1 to take forward the design of the coil forming processes and tools. Coils with different dimensions, geometries, wire sizes and types should be considered and samples built for assessing practical feasibility.	T0+12
WP3	Development of a high precision, flexible joining method.	Different materials and wire types will be tested to determine the best joining technology. A flexible setup to weld/join coils will be implemented to complete the winding system.	T0+12
WP4	Build a flexible coil forming and joining setup.	Procure and build the flexible setup and test sub-components individually against tolerances, repeatability and other key performance indices.	T0+15
WP5	Coil insertion	Design and develop tooling for accurate coil insertion, twisting and finishing towards achieving high fill factors without insulation damage.	T0+20
WP6	Design for machine stator of technology demonstrator.	This work package will apply the setup and processes developed to demonstrate technology at TRL4. The topic manager will refine the stator design to accommodate the windings proposed and the successful applicant will program and tune the setup to suit.	T0+20

Work Package	Title	Description	Due date
WP7	Build stator samples and assessment	After successful delivery of the flexible test setup to the topic manager a number of starts will be produced (~10) to assess against key performance indices such as winding DC and AC resistance, dimensional tolerances, repeatability of sample manufacturing, and winding degradation with temperature and operating environment. The topic manager will be responsible for the delivery of the stator cores and tests and the successful partner will support the topic manager as needed in the coil manufacturing process.	T0+24

3. Major Deliverables/ Milestones and schedule (estimate)

*Type: R=Report, D=Data, HW=Hardware

Deliverables			
Ref. No.	Title - Description	Type*	Due Date
D1	Report on different automated coil forming and joining methods.	R	T3
D2	Preliminary design report.	R	T7
D3	Detailed design report.	R	T12
D4	Flexible programmable setup delivered.	HW	T20
D5	Report on winding testing and assessment.	R+D	T24

Milestones (when appropriate)			
Ref. No.	Title - Description	Type*	Due Date
M1	Downselection of coil forming and joining process.		T3
M2	Preliminary design review.		T7
M3	Critical design review.		T12
M4	Stator designed and flexible, automated experimental setup delivered.		T20

4. Special skills, Capabilities, Certification expected from the Applicant(s)

The applicants need to be familiar with manufacturing technologies for electromagnetic coils. They must have demonstrable experience and expertise with manufacturing processes of electrical machine windings as well as with the development of automated processes for motor coil manufacturing.

5. Abbreviations

EMC	Electromagnetic Compatibility
HF	High Frequency
SiC	Silicon Carbide

VIII. **JTI-CS2-2018-CfP09-SYS-03-20: Demonstration and test of low-loss, high reliability, high speed, bearing-relief generators**

Type of action (RIA/IA/CSA):		RIA	
Programme Area:		SYS	
(CS2 JTP 2015) WP Ref.:		WP 100.1	
Indicative Funding Topic Value (in k€):		800	
Topic Leader:	University of Nottingham	Type of Agreement:	Implementation Agreement
Duration of the action (in Months):	24	Indicative Start Date (at the earliest)¹⁰¹:	Q3 2019

Topic Identification Code	Title
JTI-CS2-2018-CfP09-SYS-03-20	Demonstration and test of low-loss, high reliability, high speed, bearing-relief generators
Short description	
Power dense electrical generators are required to operate at high rotational speeds. Conventional, contact bearing technology is mature but limits generator efficiency, maximum rotational speeds and reliability. This project will demonstrate a new class of bearing-relief generators where radial forces are controlled electromagnetically taking loads off the bearings and additionally suppressing any rotor vibrations.	

Links to the Clean Sky 2 Programme High-level Objectives ¹⁰²				
This topic is located in the demonstration area:		Enabling technologies		
The outcome of the project will mainly contribute to the following conceptual aircraft/air transport type as presented in the scene setter:		Enabling technologies		
With expected impacts related to the Programme high-level objectives:				
Reducing CO₂ emissions	Reducing NO_x emissions	Reducing Noise emissions	Improving EU Competitiveness	Improving Mobility
<input type="checkbox"/>	<input type="checkbox"/>	<input type="checkbox"/>	<input checked="" type="checkbox"/>	<input type="checkbox"/>

¹⁰¹ The start date corresponds to actual start date with all legal documents in place.

¹⁰² For further info see Chapter 1 "Introduction to the Programme Scene Setter / Objectives" with key technology themes / demonstration areas. Detailed information available in the CS2 Development Plan accessible via the Clean Sky JU Website and EC Participant Portal.



1. Background

This project looks at demonstrating a new class of generator technologies which are able to operate at higher power density and efficiency compared to state of the art solutions. As aircraft electrical loads increase there is significant demand from electrical generators to produce higher powers whilst still improving on the power density. Key to improving power density is the ability to run at higher speeds and higher electrical frequencies. Permanent magnet generators with active rectifiers are very promising technology and will be the subject of this project.

Conventional bearing technology applied to high speed aircraft electrical generators are a source of additional losses, reduced reliability and added system complexity often requiring oil lubrication and cooling. Conventional bearing design is also challenging from a point of view of achieving compact generators as interactions with electromagnetic rotating fields may result in further losses. Magnetic bearings are often used in high-speed industry applications to counteract the disadvantages of conventional contact bearings; however, these are typically bulky and require additional passive and active components leading to significant deterioration of power density and reliability.

Work is currently under way to develop novel generator winding structures and corresponding control strategies to control generator radial forces through the main power windings and its main converter; i.e. without any additional components. This gives the possibility to relief bearing loading and suppress vibrations. Apart from reducing bearing losses, this allows for higher operational speeds and improved performance whilst still using conventional bearing technologies.

This programme of work will look at the development of a setup able to demonstrate the benefit of the proposed control technologies. The setup will include instrumentation to measure the electrical power from the generator. The generator developed by the topic manager will feed 3 separate 3-phase converters. The setup will also monitor the generator rotor spatial position, the net bearing loading during operation as well as the ability to apply the normal torque at pre-defined duty cycles and axial and radial load to the generator at the point of coupling. The programme of work will also look at accurately measuring the bearing losses under different loading conditions.

The generator main specifications are:

Rotational speed – up to 32k rpm

Dimensions – OD=250mm; Length=300mm

Rated power – 100kW (delivered from 3 x 3 phase converters)

2. Scope of work

Work Package	Title	Description	Due date
WP0	Coordination and Management	Project management, liaison with topic manager, risk management, dissemination and publication management.	T0+24

Work Package	Title	Description	Due date
WP1	Requirements and interface definition	This will look at defining the detailed interface requirements for the demonstration platform setup. The data acquisition system specification will be defined and all measurements and sensor requirements including those for electrical power, displacement, vibration, torque, force and speed derived.	T0+2
WP2	Bearing monitoring and sensor selection/development	An overview of different sensing technologies will be researched and suitability assessed to monitor shaft instantaneous position and bearing loadings. A plan for selection and development of sensing technology will be produced.	T0+6
WP3	Development of load emulator	The demonstration setup will require to model different loads seen by the electrical generator. Apart from the main load torque on the generator shaft, the demonstration platform has to also be able to exert programmable duty cycles and axial and radial loads on the generator shaft. These need to be accurately applied and measured.	T0+8
WP4	Setup design including supervisory control system	The entire setup will need to be designed to interface with the generator and its controls, diagnostics, cooling and lubrication systems. Close work with the topic manager will be required to define these. A test control setup is also to be designed by the successful applicants to enable power measurements, data capture, processing and operation.	T0+10
WP5	Manufacturing and test	The designed setup will be manufactured, assembled and the supervisory control system implemented. Subsystems will be tested separately before delivery to the Aircraft Electric Power System Innovations Laboratory at the topic manager's site.	T0+18
WP6	Assembly of the bearing-relief generator	The bearing-relief generator and its power converter and controls will be provided by the topic manager and mounted onto the test-setup by the successful applicant. The test-setup will then be commissioned and basic functionality tested making sure all the functions perform to expectation and any calibration required done.	T0+20
WP7	Test Campaign	A full test campaign will be undertaken in conjunction with the topic manager to test the full performance of the generator when operating with the novel bearing relief algorithms under different loadings.	T0+24

3. Major Deliverables/ Milestones and schedule (estimate)

*Type: R=Report, D=Data, HW=Hardware

Deliverables			
Ref. No.	Title - Description	Type*	Due Date
D1	Preliminary requirements specification	R	T3
D2	Preliminary design report of the demonstration setup	R	T7

Deliverables			
Ref. No.	Title - Description	Type*	Due Date
D3	Detailed design report of the demonstration setup	R	T10
D4	Test plan	R	T13
D5	Demonstrator setup delivered	HW	T18
D6	Test report	R+D	T24

Milestones (when appropriate)			
Ref. No.	Title - Description	Type*	Due Date
M1	Preliminary design review.	R	T7
M2	Critical design review.	R	T10
M3	Demonstration-setup assembled	HW	T20
M4	Demonstration-setup commissioned	HW	T22

4. Special skills, Capabilities, Certification expected from the Applicant(s)

- High speed test rig design capability
- Mechanical engineering design capabilities including rotordynamics
- Familiarity with bearing technologies
- Test equipment specification and commissioning capability
- Links with, or internal, capacity in test rig procurement and commissioning

IX. JTI-CS2-2018-CfP09-SYS-03-21: Aircraft wing architecture optimal assembly

Type of action (RIA/IA/CSA):		RIA	
Programme Area:		SYS	
(CS2 JTP 2015) WP Ref.:		WP 100.3	
Indicative Funding Topic Value (in k€):		500	
Topic Leader:	United Technologies Research Centre	Type of Agreement:	Implementation Agreement
Duration of the action (in Months):	18	Indicative Start Date (at the earliest)¹⁰³:	Q3 2019

Topic Identification Code	Title
JTI-CS2-2018-CfP09-SYS-03-21	Aircraft wing architecture optimal assembly
Short description	
The internal architecture of an aircraft wing contains many different systems and elements. The objective of this CFP is to deliver a design platform capable of assessing the volume and shape of the individual systems, the connections between them and other constraints within the internal wing space in order to provide a set of optimal assemblies that minimizes the overall volume. These optimal architectures should be able to integrate with the MISSION system design platform and be informed by the physics-based constraints coming from the dynamic models.	

Links to the Clean Sky 2 Programme High-level Objectives¹⁰⁴				
This topic is located in the demonstration area:		Electrical systems		
The outcome of the project will mainly contribute to the following conceptual aircraft/air transport type as presented in the scene setter:		Advanced Long and Short/Medium Range		
With expected impacts related to the Programme high-level objectives:				
Reducing CO₂ emissions	Reducing NO_x emissions	Reducing Noise emissions	Improving EU Competitiveness	Improving Mobility
<input type="checkbox"/>	<input type="checkbox"/>	<input type="checkbox"/>	<input checked="" type="checkbox"/>	<input type="checkbox"/>

¹⁰³ The start date corresponds to actual start date with all legal documents in place.

¹⁰⁴ For further info see Chapter 1 "Introduction to the Programme Scene Setter / Objectives" with key technology themes / demonstration areas. Detailed information available in the CS2 Development Plan accessible via the Clean Sky JU Website and EC Participant Portal.

1. Background

The constant growth in airplane traffic, the increasingly strict environmental regulations and efforts to make air travel cheaper, more accessible and more comfortable has driven the design of new technologies for aircraft. For many of these new technologies the interaction between the different physical domains (structural, electrical, thermal, pneumatic and hydraulic) has grown as the systems become more interconnected, this requires higher integration between aircraft systems and higher complexity in system design, analysis and verification processes.

The integration of systems with the airframe, the powerplant, and between systems means a greater number of stakeholders are involved in design iterations and therefore, the type and complexity of the data that has to be shared in order to achieve optimal designs is constantly changing and evolving as the design progresses in order to be able to verify and validate the requirements. New software tools, new methodologies to structure the data and new processes for the design of systems need to provide support for this kind of interaction between stakeholders, so that the design process can achieve better results in shorter time frames. Involving cross-disciplinary teams also adds the benefit of identifying potential design showstoppers earlier in the design process. If these disciplinary experts are involved a priori, problems in the design can be identified early on and the design changed without incurring significant cost and time delays.

The aim of WP 100.3 (MISSION – Modelling and Simulation Tools for System Integration on Aircraft) is to develop and demonstrate an integrated modelling, simulation, design and optimization framework based on MBSE principles and oriented to aerospace applications. This CfP is proposed in WP 100.3.4, which is dedicated to the development of the system level optimization platform. Within this sub-work package, there are several systems being studied: engine, electrical and thermal architecture, electrical actuation, landing gear and cockpit. In particular, this call focuses on the development of optimal assembly methods for the internal architecture of the wing (WP 100.3.4.4).

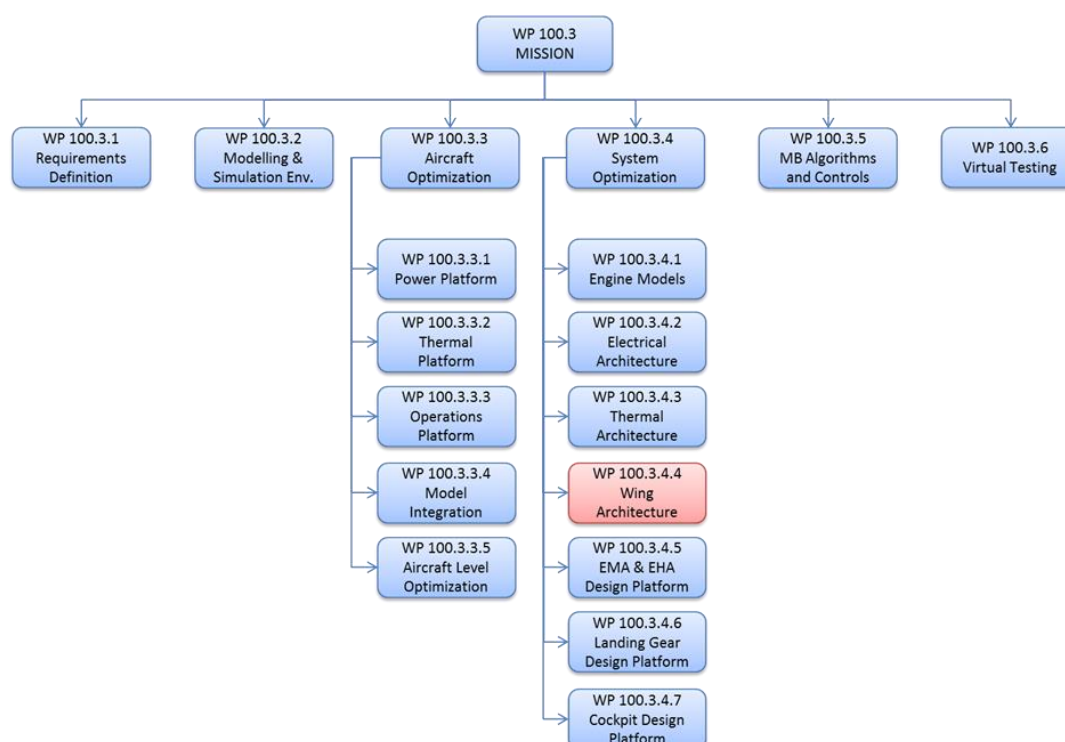



The key objective of this activity is to develop algorithms and approaches to optimize the internal architecture of the wing integrating the different systems present in the wing and studied in further detail in the other sections of the sub-work package (i.e. landing gear, wing actuation, electrical architecture), across multiple aircraft platforms. The wing architecture is comprised of structural components fixed in the airframe (spars and ribs) plus several systems that have performance and placement constraints, the connections among the systems, and with the rest of the aircraft (ducting, piping, wiring etc., which can consume significant volume relative to certain components). The fixed elements give the size and shape of the irregular 3D bounding volume and the set of system components are the items that have to be placed, oriented and interconnected within the volume, while satisfying performance-based constraints such as maximum temperature of components.

2. Scope of work

The goal of this activity is to develop a new mathematical method embodied in an algorithm(s) for optimizing the placement and orientation of a set of complex objects together with the routing of their interconnections in a relatively compact irregular bounding volume.

The optimal packaging method must include functionality to find a set of low-volume, high-performance packaging solutions with diverse topologies. In each packaging solution, 10-25 3D components are positioned and oriented within a 3D bounding volume, with a comparable number of specified interconnections routed to minimise the total packaged volume and performance losses in the interconnections (e.g., fluid-flow turning losses, proximity driven thermal losses and EMI). The interconnections should present different characteristics and routing constraints in order to represent different physical quantities being transported (i.e. an electrical wire does not have the same characteristics as a hydraulic line). The method should also be able to demonstrate the use of interconnections of varying diameters. The 3D bounding volume must be within 2 orders of magnitude larger in volume than the largest of the components and the empty space left after the components and interconnections are placed in it should be in the same order of magnitude as the largest component in order to be representative of the highly constrained spaces found in aircraft.

All the elements must be placed preventing spatial interference among any of the components', interconnections', or bounding volume's irregular 3D shapes (including concave surfaces and both blind and through holes), with connection attachment positions and orientations specified relative to the components' geometry. Other factors such as accessibility for manufacturing and maintenance complexity should be understood and considered in the method.

This goal combines two separate NP-hard problems: 3D packing and pipe routing. The industrial characteristics of the problem mean that the design space presents large infeasible region due to 3D interference and performance constraints, local optimal solutions are found within pockets of feasibility generated by very different designs. Therefore an efficient method to comprehensively explore the design space and identify the feasibility regions is needed. The use of heuristics and metaheuristics and hybrid topological/geometrical modelling methods are of particular interest if they help to eliminate large infeasible topological regions of the design space to focus the geometrical optimisation and ensure diverse solutions.

The method must be able to extract requirements and geometric parameters from detailed Modelica models of the dynamic performance of systems, already created in the system-level activities of the MISSION projects, and include the volume and performance characteristics of the system in the optimal packaging problem (i.e. a component might generate a field of electromagnetic interference around it that might preclude the positioning of other electromagnetic-dependent systems in its vicinity). The packaging algorithm must have the ability to ingest the packaging constraints generated by the performance of the components and exploit them to identify feasibility regions. The position or the

orientation of some of the components in the bounding volume might also be fixed or constrained a priori and the algorithm must be able to leverage this simplification of the problem in an efficient manner.

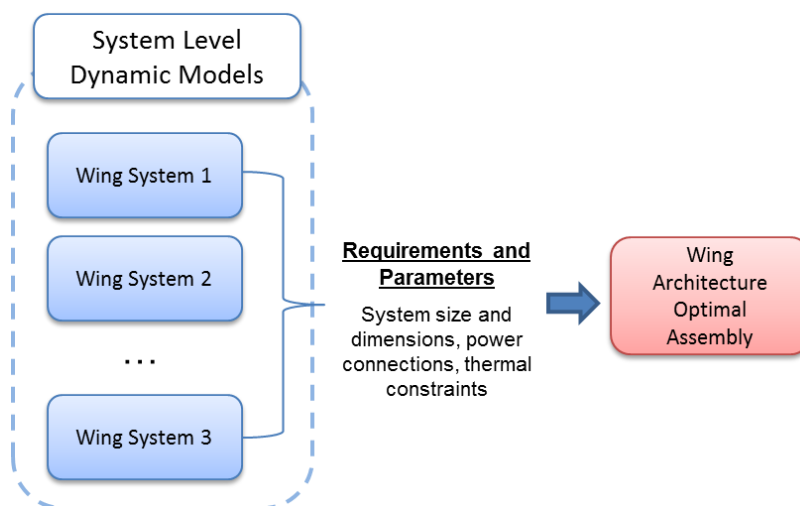

The final method should include the capability to generate locally optimal architectures including all components and interconnections, and satisfying all constraints, having explored the design space comprehensively. The method will be used to demonstrate how changes in one system have the potential to change other systems and impact the volume available inside the aircraft wing with the subsequent impact on the design of the wing itself. The comprehensive nature of the design space exploration also provides the designers alternative approaches to architecting the systems within a wing while respecting all interference constraints.

Tasks		
Ref. No.	Description	Due Date
T01	Definition of requirements and specifications	T0+4M
T02	Development of a suite of algorithms for optimal 3D assembly	T0+12M
T03	Integration of the optimal assembly algorithms with the physics-based constraints from the system design platform	T0+18M
T04	Demonstration of the optimal assembly integrated with the systems design platform	T0+18M

3. Major Deliverables/ Milestones and schedule (estimate)

*Types: R=Report, D-Data, HW=Hardware, Spec = Specifications, Demo = Demonstration

Tentative Gantt chart schedule:

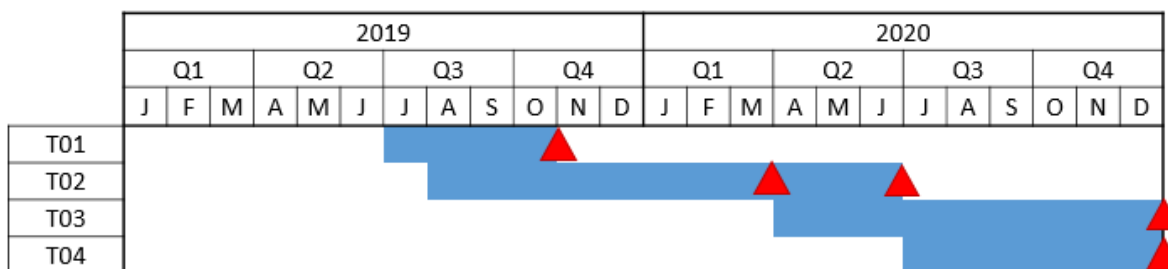

Deliverables			
Ref. No.	Description	Type*	Due Date
D01.a	Algorithm specification including the system requirements, 3D volume constraints and verification strategy	Spec	T0+4M
D01.b	State of the Art in 3D and routing algorithm document	R	T0+4M
D02.a	Optimal 3D assembly algorithm and documentation	D + R	T0+8M
D02.b	Wing architecture assembly: algorithm demonstration	Demo	T0+11M
D03.a	Optimal assembly algorithm including physics based constraints	D + R	T0+18M
D04.a	Wing architecture assembly: system level integration demo	Demo+R	T0+18M

4. Special skills, Capabilities, Certification expected from the Applicant(s)

- Experience in 3D packaging design problems, pipe routing problems, connection routing optimization, topology optimization
- Experience in integrating physics-based constraints into geometrical design spaces
- Expertise in MBSE methodologies to manage system requirements and support design activities.
- Experience and competence in management of multidisciplinary research projects within national and EU-funded programs
- Experience in collaborating with aeronautical companies, industrial partners, and research centers on national and international joint efforts in research and development programs.
- Ensure efficient management of study and development phases.

5. Abbreviations

MBSE	Model-Based Systems Engineering
MISSION	Modelling and Simulation Tools for System Integration on Aircraft
NP-hard	Non-deterministic Polynomial-time - hard
EMI	Electro Magnetic Interference

X. JTI-CS2-2018-CfP09-SYS-03-22: Virtual Testing Based Certification

Type of action (RIA/IA/CSA):		IA	
Programme Area:		SYS	
(CS2 JTP 2015) WP Ref.:		WP 100.3	
Indicative Funding Topic Value (in k€):		500	
Topic Leader:	dSPACE	Type of Agreement:	Implementation Agreement
Duration of the action (in Months):	30	Indicative Start Date (at the earliest)¹⁰⁵:	Q3 2019

Topic Identification Code	Title
JTI-CS2-2018-CfP09-SYS-03-22	Virtual Testing Based Certification
Short description	
The objective of this Topic consists in the analysis of current aerospace standards and guidelines as well as their application in the industry with a special focus on aircraft certification based on virtual testing in order to define innovative processes, best practices and related proposals to enhance relevant standards. The task will contribute to improvements for more efficient, faster and easier-to-certify development and implementation of features and functions, thus enabling mature processes for a more competitive European aerospace industry.	

Links to the Clean Sky 2 Programme High-level Objectives¹⁰⁶				
This topic is located in the demonstration area:		Enabling technologies		
The outcome of the project will mainly contribute to the following conceptual aircraft/air transport type as presented in the scene setter:		Enabling technologies		
With expected impacts related to the Programme high-level objectives:				
Reducing CO₂ emissions	Reducing NO_x emissions	Reducing Noise emissions	Improving EU Competitiveness	Improving Mobility
<input type="checkbox"/>	<input type="checkbox"/>	<input type="checkbox"/>	<input checked="" type="checkbox"/>	<input type="checkbox"/>

¹⁰⁵ The start date corresponds to actual start date with all legal documents in place.

¹⁰⁶ For further info see Chapter 1 "Introduction to the Programme Scene Setter / Objectives" with key technology themes / demonstration areas. Detailed information available in the CS2 Development Plan accessible via the Clean Sky JU Website and EC Participant Portal.

1. Background

Market drivers such as operational considerations, societal concerns and increased consumer expectations are resulting in aircraft manufacturers designing a new generation of highly efficient aircraft characterised by new levels of comfort, system integration, and optimised aerodynamics. The high level of system integration that is characteristic of new aircraft designs is dramatically increasing the complexity of both design and verification. Simultaneously, the multi-physics interactions between structural, electrical, thermal, and hydraulic components have become more significant as the systems become increasingly interconnected (e.g. the interaction between thermal load due to increased cabin electrical power usage, an electrically-powered environmental control system, and electrically powered flight control actuation). New and optimized methodologies, tools, and processes are therefore required to enable better coordination between different design disciplines, as well as to optimize verification and validation of next generation of aircraft systems.

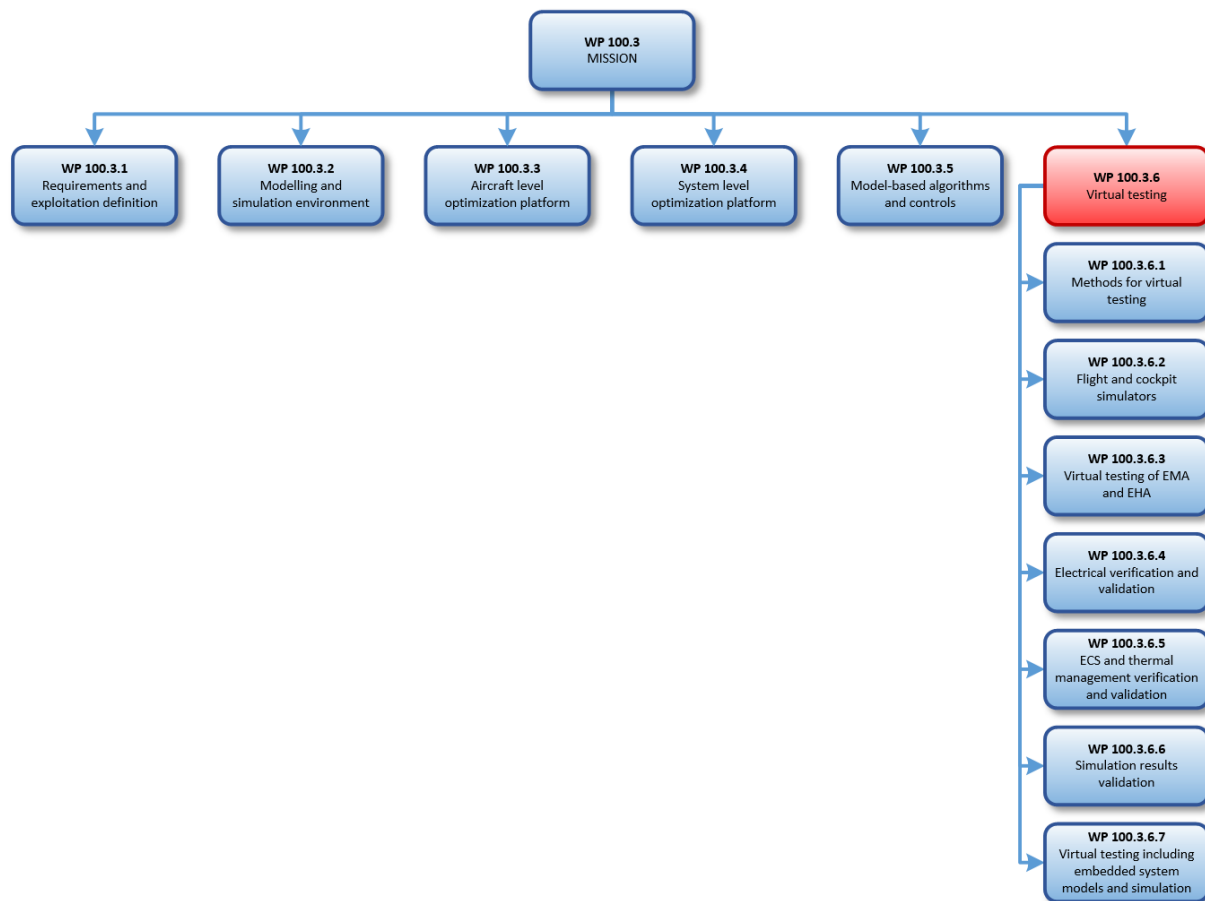

The aim of WP 100.3 (MISSION – Modelling and Simulation Tools for System Integration on Aircraft) is to develop and demonstrate an integrated modelling, simulation, design and optimization framework based on Model-Based Systems Engineering (MBSE) and oriented to the aerospace industry. This framework will holistically support the entire design, development and test process of an aircraft, starting from conceptual aircraft-level design, toward capture of key requirements, system design, integration, validation and verification.

Specifically, this Topic is proposed for MISSION WP 100.3.6, which is focusing on the investigation and



benefits of virtual testing methods including corresponding demonstrators for different aerospace applications identified in CS2 SYS ITD with special regard to the certifiability of systems based partially on virtual testing. To address this challenge, modelling tools and heterogeneous environments are harmonised to support integrated testing and – where possible – enable virtual testing.

2. Scope of work

Tasks		
Ref. No.	Title – Description	Due Date
T01	Analysis of aerospace standards and guidelines with regard to state-of-the-art virtual testing	T0+12M
T02	Interactions with standardization groups and certification authorities	T0+27M
T03	Development of best practices as well as proposals for enhancement of standards and guidelines	T0+30M

The scope of this Topic consists in the analysis of current aerospace standards and guidelines as well as their application in the industry with a special focus on aircraft certification based on virtual testing in order to define innovative processes, best practices and related proposals to enhance relevant standards. The targeted contributions include improvements for more efficient, faster and easier-to-certify development and implementation of features and functions. These improvements are required to enable mature processes for a more competitive European aerospace industry.

The work must take into account the state-of-the-art application of virtual testing methods (MIL, SIL, VPIL, and HIL) as well as challenges related to design and verification processes, such as dividing tasks between system suppliers and aircraft manufacturers and hence accelerating the certifiability of next generation of systems

With this basis the applicant has to identify potential gaps in standards and guidelines focusing on providing verification evidence by means of virtual testing eligible for aircraft certification. In this context, the results of the study need to include definitions of innovative processes for optimizing the benefits of virtual testing in aircraft development as well as related proposals for improving standards and guidelines that the applicant must draft in close collaboration with the Topic Manager, standardization groups, and certification authorities. Regular consultations of the applicant and the Topic Manager with EASA as reviewer of interim results are mandatory.

3. Major Deliverables/ Milestones and schedule (estimate)

*Type: R=Report, D=Data, HW=Hardware

Tentative Gantt chart

	2019												2020												2021											
	Q1			Q2			Q3			Q4			Q1			Q2			Q3			Q4			Q1			Q2			Q3			Q4		
	1	2	3	4	5	6	7	8	9	10	11	12	1	2	3	4	5	6	7	8	9	10	11	12	1	2	3	4	5	6	7	8	9	10	11	12
T01																																				
T02																																				
T03																																				

Deliverables			
Ref. No.	Title - Description	Type*	Due Date
D01.a	Gap analysis: Coverage of virtual testing methods in current aerospace standards and guidelines vs. state-of-the-art application in the industry	R	T0+12M
D01.b	Challenges in the current aircraft certification process and potential benefits of state-of-the-art virtual testing methods	R	T0+18M
D01.c	Innovative processes and best practices for application of virtual testing methods for aircraft certification	R	T0+27M
D01.d	Proposal for enhancement of aerospace standards and guidelines with regard to virtual testing	R	T0+30M

4. Special skills, Capabilities, Certification expected from the Applicant(s)

- Expertise in verification, validation and certification processes and methods currently applied in the aerospace industry, including a thorough understanding of the associated present and future challenges.
- Expertise in aerospace standards and guidelines related to verification and validation of systems and certification of aircraft.
- Expertise in virtual testing methods (HIL and at least one of the following: MIL, SIL, VPIL).
- Experience and competence in management of multidisciplinary research projects within national and EU-funded programs.
- Experience in collaborating with aeronautical companies, industrial partners, certification authorities (e.g., EASA) and research centres on national and international joint efforts in research and development programs.
- Ensure efficient management of study and development phases.

5. Abbreviations

HIL	Hardware-in-the-Loop
MBSE	Model-Based Systems Engineering
MIL	Model-in-the-Loop
MISSION	Modelling and Simulation Tools for System Integration on Aircraft
SIL	Software-in-the-Loop
VPIL	Virtual Processor-in-the-Loop

9. Clean Sky 2 – Technology Evaluator

I. JTI-CS2-2018-CfP09-TE-01-07: Alternative energy sources and novel propulsion technologies

Type of action (RIA/IA/CSA):		CSA	
Programme Area:		TE	
(CS2 JTP 2015) WP Ref.:		WP 3, WP 5	
Indicative Funding Topic Value (in k€):		350	
Topic Leader:	DLR	Type of Agreement:	Implementation Agreement
Duration of the action (in Months):	24	Indicative Start Date (at the earliest)¹⁰⁷:	Q3 2019

Topic Identification Code	Title
JTI-CS2-2018-CfP09-TE-01-07	Alternative energy sources and novel propulsion technologies
Short description	
Inclusion of alternative energy sources and novel propulsion to future fleets can be an important means to reduce the environmental impact. The CSA will provide an overview of potential future energy sources and the relevant propulsion technologies for them. The CSA will determine which seat classes in the fleet are relevant for which energy source and technology combination. The time frame to be covered will be 2035 to 2050.	

Links to the Clean Sky 2 Programme High-level Objectives ¹⁰⁸				
This topic is located in the demonstration area:		NA		
The outcome of the project will mainly contribute to the following conceptual aircraft/air transport type as presented in the scene setter:		NA		
With expected impacts related to the Programme high-level objectives:				
Reducing CO₂ emissions	Reducing NO_x emissions	Reducing Noise emissions	Improving EU Competitiveness	Improving Mobility
<input checked="" type="checkbox"/>	<input checked="" type="checkbox"/>	<input type="checkbox"/>	<input type="checkbox"/>	<input type="checkbox"/>

¹⁰⁷ The start date corresponds to actual start date with all legal documents in place.

¹⁰⁸ For further info see Chapter 1 "Introduction to the Programme Scene Setter / Objectives" with key technology themes / demonstration areas. Detailed information available in the CS2 Development Plan accessible via the Clean Sky JU Website and EC Participant Portal.



1. Background

Cross-positioned within the Clean Sky 2 Programme, the Technology Evaluator (TE) is a dedicated evaluation platform. Its main function is to assess the environmental impact of the technologies developed in Clean Sky 2. In relation to well-defined environmental (noise, CO₂, NO_x) and societal benefits and targets the contribution of these new technologies is additionally estimated addressing their overall impact.

The corresponding technologies are developed within Innovative Aircraft Demonstrator Platforms (IADPs) and Integrated Technology Demonstrators (ITDs) and they are clustered in coherent and mutually compatible solution sets, defining concept aircraft models. In-depth assessments of these concept aircraft models will be conducted on three levels:

- **Mission level**
A Clean Sky 2 concept aircraft and its reference aircraft model¹⁰⁹ is compared along the same trajectory in order to determine the environmental benefit of the Clean Sky 2 technologies, namely noise on ground and emissions (CO₂ and NO_x).
- **Airport level**
Clean Sky 2 concept aircraft models replace their reference technology counterpart at different time scales (2015/2020/2035/2050) in terms of airport traffic scenarios. The purpose of this replacement approach is to evaluate the full potential of environmental benefits of Clean Sky 2 technologies on airport level by concentrating on noise on the ground and the population affected by certain noise levels and emissions (CO₂ and NO_x).
- **Air transport system (ATS) level**
Similar to the airport level, Clean Sky 2 concept aircraft models replace their reference technology counterpart at different time scales (2015/2020/2035/2050) in terms of complete traffic scenarios. In this respect, the resulting impact is measured on a global scale.

This call addresses the topic of alternative energy sources and propulsion technologies through the instrument of a CSA (Coordination and Support Activity).

Alternative energy sources have the potential of a high contribution to emissions reduction in the future air transport system. For instance, various trials with aviation fuel blends containing fuel from renewable sources have been conducted in the recent past. All projects have in common that fuels from renewable sources are designed as drop-in fuels, so that current infrastructure in fuel supply and engine technology can be maintained. A key challenge is to find an environmentally friendly and cost-efficient production route, optimising feedstock and energy input.

Propulsion technologies have been at the forefront of aeronautics when achieving significant fuel consumption reduction. In this topic the TE requests the development of a technology roadmap for alternative propulsion technologies for civil aviation for the timeframe 2035-2050. This roadmap must encompass detailed descriptions of the alternative technology, such as hybrid-electric powertrains and future advanced gas turbine concepts. Furthermore an assessment of the impact of these alternative solutions on total energy consumption on vehicle level needs to be provided. In a further step the diffusion of these technologies into the future fleet is to be estimated.

¹⁰⁹ The reference aircraft model refers to an aircraft having entered into the market in the year 2014.

2. Scope of work

Through the CSA the following questions should be addressed and the state-of-the-art knowledge is to be exchanged through a series of workshops:

- What are well-suited energy sources in terms of energy density and other relevant properties on air vehicle level?
A selection of five alternative fuel candidates based on state of the art knowledge), considering the whole aircraft system (combination of propulsion technology and energy source) shall be the outcome of this task. Here drop in fuels and also more revolutionary concepts are to be considered (biofuels, LNG, LH2, slush LNG, batteries, fuel cells, Hybrid Systems, STL, CTL, etc.).
- What is the ecological balance sheet of such fuels accounted for over their life cycle (from 'production' to usage as propellant)?
- What are viable technologies for alternative propulsion concepts (e.g. Inter-cooled Recuperated Engine, Constant Vol. combustion, pressure gain combustion, hybrid cycles, composite cycles, hybrid electric, electric propulsion etc) and what is their estimated TRL in the timeframe 2035-2050? What would be the expected technology roadmap?
- What is the impact of such alternative energy sources and propulsion technologies on vehicle level in terms of propulsion system architecture and gaseous emissions?
- What would be the environmental impact on the air transport system of the selected energy sources for future fleets and the diffusion into relevant seat classes within the time span 2035 to 2050? What would be the roadmap in terms of economic viability and availability of those energy sources setting the path towards industrial use?
- How will such novel energy sources and propulsion concepts diffuse into air vehicle seat classes?

In addition to literature research, applicants shall organize three workshops inviting relevant experts. The results will be compiled in a final report.

Tasks		
Ref. No.	Title – Description	Due Date
1	Literature research on alternative energy sources and propulsion concepts in aviation (including technologies, their advantages, disadvantages, potential show stoppers, risk map, TRL roadmap)	Month 12
2	Organisation of three workshops addressing the key questions posed (see above)	Month 3, 12, 20
3	Final dissemination workshop	24

Proposals may include the commitment from the European Aviation Safety Agency to assist or to participate in the action.

3. Major Deliverables/ Milestones and schedule (estimate)

*Type: R=Report, D=Data, HW=Hardware

Deliverables			
Ref. No.	Title – Description	Type*	Due Date
1	Dedicated workshops reports	R	Month 3, 12, 21
2	Final results alternative energy and propulsion technologies literature study	R	Month 12



Deliverables			
Ref. No.	Title – Description	Type*	Due Date
3	Final Road-mapping results		24

4. Special skills, Capabilities, Certification expected from the Applicant(s)

- Profound expertise in aviation propulsion technology assessment in combination with aviation fuels and the development of technology roadmaps
- Profound expertise in alternative aviation fuels
- Proven ability to develop expert workshop concepts and ability to moderate such workshops
- Ability to deliver clear and concise reports in English

5. Abbreviations

CTL	Carbon To Liquid
LNG	Liquefied Natural GAS
STL	Sun To Liquid
TRL	Technology Readiness Level

II. JTI-CS2-2018-CfP09-TE-01-08: Overall Air Transport System Vehicle Scenarios

Type of action (RIA/IA/CSA):		CSA	
Programme Area:		TE	
(CS2 JTP 2015) WP Ref.:		WP 5	
Indicative Funding Topic Value (in k€):		300	
Topic Leader:	DLR	Type of Agreement:	Implementation Agreement
Duration of the action (in Months):	12	Indicative Start Date (at the earliest)¹¹⁰:	Q3 2019

Topic Identification Code	Title
JTI-CS2-2018-CfP09-TE-01-08	Overall Air Transport System Vehicle Scenarios
Short description	
New innovative vehicle technologies such as UAV, Air Taxi, or Supersonic aircraft bear potentials to improve passenger mobility and change the face of future aviation. The study shall provide a set of two scenarios (high vs low market penetration) from 2035 up to 2050, including forecasts of fleet & movements plus a transparent description of the scenario drivers, assumptions and applied data sources as well as the forecast methodology.	

Links to the Clean Sky 2 Programme High-level Objectives¹¹¹				
This topic is located in the demonstration area:		NA		
The outcome of the project will mainly contribute to the following conceptual aircraft/air transport type as presented in the scene setter:		NA		
With expected impacts related to the Programme high-level objectives:				
Reducing CO₂ emissions	Reducing NO_x emissions	Reducing Noise emissions	Improving EU Competitiveness	Improving Mobility
<input checked="" type="checkbox"/>	<input checked="" type="checkbox"/>	<input checked="" type="checkbox"/>	<input checked="" type="checkbox"/>	<input checked="" type="checkbox"/>

¹¹⁰ The start date corresponds to actual start date with all legal documents in place.

¹¹¹ For further info see Chapter 1 "Introduction to the Programme Scene Setter / Objectives" with key technology themes / demonstration areas. Detailed information available in the CS2 Development Plan accessible via the Clean Sky JU Website and EC Participant Portal.



1. Background

Cross-positioned within the Clean Sky 2 Programme, the Technology Evaluator (TE) is a dedicated evaluation platform. Its main function is to assess the environmental impact of the technologies developed in Clean Sky 2. In relation to well-defined environmental (noise, CO₂, NO_x) and societal benefits and targets the contribution of these new technologies is additionally estimated addressing their overall impact.

The corresponding technologies are developed within Innovative Aircraft Demonstrator Platforms (IADPs) and Integrated Technology Demonstrators (ITDs) and they are clustered in coherent and mutually compatible solution sets, defining concept aircraft models. In-depth assessments of these concept aircraft models will be conducted on three levels:

- **Mission level**
A Clean Sky 2 concept aircraft and its reference aircraft model¹¹² is compared along the same trajectory in order to determine the environmental benefit of the Clean Sky 2 technologies, namely noise on ground and emissions (CO₂ and NO_x).
- **Airport level**
Clean Sky 2 concept aircraft models replace their reference technology counterpart at different time scales (2015/2020/2035/2050) in terms of airport traffic scenarios. The purpose of this replacement approach is to evaluate the full potential of environmental benefits of Clean Sky 2 technologies on airport level by concentrating on noise on the ground and the population affected by certain noise levels and emissions (CO₂ and NO_x).
- **Air transport system (ATS) level**
Similar to the airport level, Clean Sky 2 concept aircraft models replace their reference technology counterpart at different time scales (2015/2020/2035/2050) in terms of complete traffic scenarios. In this respect, the resulting impact is measured on a global scale.

This call addresses the extension of TE forecasts through the development of a set of parallel scenarios for the time horizon 2035 until 2050 on the diffusion of vehicles which are not addressed within Clean Sky, namely Unpiloted Air Vehicles (UAV) and supersonic aircraft. The purpose of these scenarios is to complete the CS2 TE forecasts regarding mainliner, regional aircraft, fast rotorcraft, small air transport (SAT) and rotorcraft – and to provide a more realistic view on future aviation beyond global fleet forecasts/scenarios composed of only Clean Sky 2 vehicles.

The corresponding work strengthens the TE ATS level forecasts by providing additional scenarios on non-Clean Sky vehicles such as UAV, air taxis and supersonic aircraft, which will allow the TE to devise more realistic fleet compositions for a given global fleet scenario. In the ATS level forecasts this fleet is currently composed of Clean Sky 2 vehicles, which represent a limited fraction of future aviation vehicles. The additional scenarios enable the TE to improve the fleet composition through estimating the potential substitutions and market overlaps of Clean Sky aircraft by non-Clean Sky vehicles.

2. Scope of work

The scenarios shall be developed in the following steps:

¹¹² The reference aircraft model refers to an aircraft having entered into the market in the year 2014.



a) Review of available forecasts on UAV and supersonic aircraft

The Partner should compare the various available forecasts in terms of assumptions, data sources, relevance of drivers and variables. In addition, the Partner should draft a clear and concise comparison, highlighting the most relevant, existing statistical and information gaps.

b) Fine-tuning of the forecasting approach

The Partner should agree with the Topic Manager which approach should be selected to pursue the forecasting and scenario work including the assumptions, drivers and especially the market potential targeted by the vehicles.

The model used for forecasting should focus on passenger transport and provide results on expected movements between airports or UAV-ports in terms of number of trips, average journey times and average distances.

In case the Partner likes to apply an own forecast and scenario tool, he should use the expected GDP growth figures from Global Insight. In addition, the Partner will be provided by the Topic Manager with data on the expected population growth.

When data is lacking for certain variables, the Partner should provide an approach to fill the gaps, which will be discussed and agreed with the Topic Manager and the relevant Clean Sky 2 Members at the start of the Grant Preparation Phase.

c) Production of scenarios

The 2050 scenarios on UAV and supersonic aircraft shall start with 2035. The scenarios should quantify fleet and movements for the years 2035 and 2050 and shall be carried out at country/region/world levels.

3. Major Deliverables/ Milestones and schedule (estimate)

Concerning the major deliverables and milestones as well as the corresponding schedule the following course of action is foreseen:

- **Month 2 – Kick-off meeting (1 day) in Brussels**

The meeting will be organised by the Topic Manager. The Partner should present to the Topic Manager and relevant Clean Sky 2 Members the comparison of the various available forecasts in terms of assumptions, data sources, and relevance of drivers and variables, highlighting the most relevant, existing statistical and information gaps. In addition, the Partner should put forward for discussion a proposal on the approach to fill the statistical and information gaps.

- **Month 4 – Submission of the first report to the JU**

This report should contain in detail:

- summary of the discussions during the kick-off meeting with the Topic Manager and relevant Clean Sky 2 Members
- comparison of the various available forecasts in terms of assumptions, data sources, and relevance of drivers and variables, highlighting the most relevant, existing statistical and information gaps



- defined approach to fill the statistical and information gaps

- Month 8 – Intermediate meeting I (1 day) in Brussels

The meeting will be organised by the Topic Manager. The Partner should present the first scenario results to the Topic Manager and relevant Clean Sky 2 Members.

- Month 9 - Submission of the draft final report to the JU

This report should contain in detail the first scenario results including the remarks made during Intermediate meeting I.

- Month 10 – Intermediate meeting II (1 day) in Brussels

The meeting will be organised by the Topic Manager. The Partner should present the revised scenario results to the Topic Manager and relevant Clean Sky 2 Members.

- Month 12 – Final meeting (1 day) in Brussels

The meeting will be organised by the Topic Manager. The Partner should present the final scenarios to the Topic Manager and relevant Clean Sky 2 Members.

- Month 12 – Submission of the final report to the JU

This report should contain in detail:

- road maps from 2035 until 2050 for the market development of new generations of UAV and supersonic aircraft
- description of the results including detailed movements matrices
- abstract and an executive summary of a maximum of 6 pages
- recommendations

Regarding data and results, they should also be provided in electronic form (i.e. Excel, csv, txt or equivalent).

4. Special skills, Capabilities, Certification expected from the Applicant(s)

Applicants should have the following skills and expertise:

- Profound expertise in technology assessment and technology diffusion analysis
- Profound knowledge regarding the elaboration of aviation scenarios
- Profound knowledge of aviation forecast models
- Expertise in forecasting
- Experience in analysing and reporting on long-term trends for air traffic
- Access to an appropriate methodology including the ability to quantify vehicle improvements and their impact on the market diffusion and fleet development
- Awareness of current literature relevant to long-term trends
- Ability to deliver clear and concise reports in English
- For the proposal it is furthermore required, that applicants describe how the fleet development and scenarios will be quantified.

5. Abbreviations

UAV Unpiloted Air Vehicles

III. JTI-CS2-2018-CfP09-TE-01-09: Environmental regulations and policies

Type of action (RIA/IA/CSA):		CSA	
Programme Area:		TE	
(CS2 JTP 2015) WP Ref.:		WP 5	
Indicative Funding Topic Value (in k€):		200	
Topic Leader:	DLR	Type of Agreement:	Implementation Agreement
Duration of the action (in Months):	12	Indicative Start Date (at the earliest)¹¹³:	Q3 2019

Topic Identification Code	Title
JTI-CS2-2018-CfP09-TE-01-09	Environmental regulations and policies
Short description	
Environmental regulations and policies bear potential to reduce the environmental impact of aviation. The study shall provide an overview of currently discussed measures which can be applied on a global scale. In addition, the study shall provide detailed inputs on the potential impacts of those measures regarding the emission reduction, aircraft technology, fleet evolution and market impacts.	

Links to the Clean Sky 2 Programme High-level Objectives ¹¹⁴				
This topic is located in the demonstration area:		NA		
The outcome of the project will mainly contribute to the following conceptual aircraft/air transport type as presented in the scene setter:		NA		
With expected impacts related to the Programme high-level objectives:				
Reducing CO ₂ emissions	Reducing NO _x emissions	Reducing Noise emissions	Improving EU Competitiveness	Improving Mobility
<input checked="" type="checkbox"/>	<input checked="" type="checkbox"/>	<input checked="" type="checkbox"/>	<input type="checkbox"/>	<input type="checkbox"/>

¹¹³ The start date corresponds to actual start date with all legal documents in place.

¹¹⁴ For further info see Chapter 1 "Introduction to the Programme Scene Setter / Objectives" with key technology themes / demonstration areas. Detailed information available in the CS2 Development Plan accessible via the Clean Sky JU Website and EC Participant Portal.



1. Background

Cross-positioned within the Clean Sky 2 Programme, the Technology Evaluator (TE) is a dedicated evaluation platform. Its main function is to assess the environmental impact of the technologies developed in Clean Sky 2. In relation to well-defined environmental (noise, CO₂, NO_x) and societal benefits and targets the contribution of these new technologies is additionally estimated addressing their overall impact.

The corresponding technologies are developed within Innovative Aircraft Demonstrator Platforms (IADPs) and Integrated Technology Demonstrators (ITDs) and they are clustered in coherent and mutually compatible solution sets, defining concept aircraft models. In-depth assessments of these concept aircraft models will be conducted on three levels:

- **Mission level**
A Clean Sky 2 concept aircraft and its reference aircraft model¹¹⁵ is compared along the same trajectory in order to determine the environmental benefit of the Clean Sky 2 technologies, namely noise on ground and emissions (CO₂ and NO_x).
- **Airport level**
Clean Sky 2 concept aircraft models replace their reference technology counterpart at different time scales (2015/2020/2035/2050) in terms of airport traffic scenarios. The purpose of this replacement approach is to evaluate the full potential of environmental benefits of Clean Sky 2 technologies on airport level by concentrating on noise on the ground and the population affected by certain noise levels and emissions (CO₂ and NO_x).
- **Air transport system (ATS) level**
Similar to the airport level, Clean Sky 2 concept aircraft models replace their reference technology counterpart at different time scales (2015/2020/2035/2050) in terms of complete traffic scenarios. In this respect, the resulting impact is measured on a global scale.

This call addresses the extension of TE assessments on ATS level through estimation on regulations and policies and their potential impact on emission/noise reductions. The purpose of this estimation is to understand, which additional reductions can be achieved in addition to Clean Sky 2 technology improvements. Such understanding shall help to evaluate to which extent technology diffusion in aviation can reach ACARE Flightpath 2050 environmental goals.

2. Scope of work

The project shall be performed in the following steps:

- a) Elaboration of a list of aviation policies and regulations

The Partner should investigate literature on aviation policies and regulations and provide a list of promising measures (potentially introduced until the year 2040) plus a reasoning to consider them in the further project work. The Partner shall also provide a list of metrics/indicators to measure the reduction of environmental impacts – plus a reasoning to apply them in the further project work.

- b) Selection of aviation policies and regulations which shall be further investigated regarding

¹¹⁵ The reference aircraft model refers to an aircraft having entered into the market in the year 2014.



their potential in terms of emission and noise reductions

The Partner should agree with the Topic Manager and the Clean Sky 2 Executive Team on aviation policies and regulations as well as on metrics/indicators to measure reduction potential to be considered / applied in the further project work.

Measures to be considered are especially those, which have impacts on technology, fleet and movements development, e.g.:

- Vehicle emission standards
- Emission Trading
- Movement restrictions on specific airports
- Aircraft age related bans

Metrics and indicators to be considered are e.g.:

- For noise: Lden, noise energy, noise contours at airports, population annoyed by noise
- For emissions: tonnes absolute/per flight/per passenger kilometre
- For both mentioned categories: change in percentage compared to a BAU scenario or to a specific year

c) Review of available aviation policy/regulation assessments

The Partner should compare the various available policy/regulation assessments in terms of assumptions, data sources, relevance of drivers and variables. In addition, the Partner should draft a clear and concise comparison, highlighting the most relevant existing statistical and information gaps.

d) Fine-tuning of the impact assessment approach

The Partner should agree with the Topic Manager which approach should be selected for the quantification of potential emission and noise reductions (up to the year 2050), including the assumptions, drivers and effectiveness of such measures.

The models used for impact assessments should focus on passenger transport and provide results on expected emission and noise reductions.

In case the Partner likes to apply an own policy assessment tool, he should use the expected GDP growth figures from Global Insight. In addition, the Partner will be provided by the Topic Manager with data on the expected population growth in relevant world regions.

When data is lacking for certain variables, the Partner should provide an approach to fill the gaps, which will be discussed and agreed with the Topic Manager and the relevant Clean Sky 2 Members.

e) Production of impact assessments

The policy assessments shall quantify emission and noise reductions.

3. Major Deliverables/ Milestones and schedule (estimate)

Concerning the major deliverables and milestones as well as the corresponding schedule the following course of action is foreseen:



- Month 2 – Kick-off meeting (1 day) in Brussels

The meeting will be organised by the Topic Manager. The Partner should present to the Topic Manager and relevant Clean Sky 2 Members a list of aviation policies and regulations (potentially introduced until the year 2040) plus a reasoning to consider them in the further project work, based on criteria such as acceptance, reduction potential, efficiency. The Partner should present as well a list of metrics and indicators to measure reduction potential.

- Month 4 – Submission of the first report to the JU

This report should contain in detail:

- summary of the discussions during the kick-off meeting with the Topic Manager and relevant Clean Sky 2 Members
- findings of the literature review of various available policy/regulation assessments in terms of assumptions, data sources, relevance of drivers and variables
- description of the approach to further investigate the emission and noise reduction potential up to 2050

- Month 10 – Intermediate meeting (1 day) in Brussels

The meeting will be organised by the Topic Manager. The Partner should present to the Topic Manager and relevant Clean Sky 2 Members the first results on measures and their reduction potential.

- Month 12 – Final meeting (1 day) in Brussels

The meeting will be organised by the Topic Manager. The Partner should present to the Topic Manager and relevant Clean Sky 2 Members the final results, including the remarks made during the Intermediate meeting.

- Month 12 – Submission of the final report to the JU

This report should contain in detail:

- description of the results including detailed emission and noise reduction matrices (if applicable impacts regarding specific aircraft types, airports, countries, continents)
- abstract and an executive summary of a maximum of 6 pages
- recommendations

Regarding data and results, they should also be provided in electronic form (i.e. Excel, csv, txt or equivalent).

4. Special skills, Capabilities, Certification expected from the Applicant(s)

Applicants should have the following skills and expertise:

- Profound expertise in aviation policy assessments
- Profound knowledge of aviation models for impact quantifications
- Ability to deliver clear and concise reports in English

5. Abbreviations

BAU Business As Usual

PART B: Thematic Topics

1. Overview of Thematic Topics

List of Topics for Calls for Proposals (CFP09) – Part B

Identification Code	Title	Type of Action	Value (Funding in M€)
JTI-CS2-2018-CFP09-THT-03	Conceptual Design of a 19 passenger Commuter Aircraft with near zero emissions	RIA	0.75
JTI-CS2-2018-CFP09-THT-04	Design Optimisation providing optimum performance towards limiting aviation's contribution towards Global Warming	RIA	0.75
JTI-CS2-2018-CFP09-THT-05	Advanced High Bypass Ratio Low-Speed Composite Fan Design and Validation	RIA	2.00
JTI-CS2-2018-CFP09-THT-06	Research for the development of Particulate Matter (PM) regulations and guidelines	RIA	1.00

2. Call Rules

Before submitting any proposals to the topics proposed in the Clean Sky 2 Call for Proposals, all applicants shall refer to the applicable rules as presented in the “*Second Amended Work Plan 2018-2019*”¹¹⁶ and the “*Rules for submission, evaluation, selection, award and review procedures of Calls for Proposals*”¹¹⁷.

IMPORTANT:

The “additional conditions” laid down in the CS2JU Work Plan (see chapter 3.3 “*Call management rules*”) are **not applicable** to the topics listed in Part B of this Annex .

Special conditions apply to these topics which are launched outside the complementary framework of an IADP/ITD/TA (hereinafter referred to as Thematic Topics):

- **Page limit:**

The limit for a full proposal answering a Thematic Topic is **30 pages** in total, see proposal template B.I.

- **Scoring and weighting:**

For Thematic Topics: to determine the ranking, the score for the criterion ‘excellence’ will be given a weight of 1.5.

- **Admissibility**

¹¹⁶Doc. ref. CS-GB-2018-10-19 Seconded Amended WP and Bidget 2018-2019, available on the Participant Portal and the Clean Sky website

¹¹⁷Doc. ref. Written Proc. 2014 -11 CS2 Rules for submission CfP, available on the Participant Portal and the Clean Sky website



Standard admissibility conditions and related requirements as laid down in Part B of the General Annex of the Work Programme shall apply mutatis mutandis with the following additional condition(s) introduced below:

- The 16 Leaders of JU listed in Annex II to Regulation n° (EU) No 558/2014 and their affiliates¹¹⁸ **may not apply** to the topics listed in Part B of this Annex .

Please note that proposals may include the commitment from the European Aviation Safety Agency (EASA) to assist or to participate in the action without EASA being eligible for funding.

3. Programme Scene setter/Objectives

In accordance with Article 2 of the COUNCIL REGULATION (EU) No 558/2014 of 6 May 2014¹¹⁹ the **Clean Sky 2 high-level (environmental) objectives are:**

“(b) to contribute to improving the environmental impact of aeronautical technologies, including those relating to small aviation, as well as to developing a strong and globally competitive aeronautical industry and supply chain in Europe.

This can be realised through speeding up the development of cleaner air transport technologies for earliest possible deployment, and in particular the integration, demonstration and validation of technologies capable of:

- (i) increasing aircraft fuel efficiency, thus reducing CO₂ emissions by 20 to 30 % compared to ‘state-of-the-art’ aircraft entering into service as from 2014;*
- (ii) reducing aircraft NO_x and noise emissions by 20 to 30 % compared to ‘state-of-the-art’ aircraft entering into service as from 2014.”*

These Programme's high-level (environmental) objectives have been translated into **targeted vehicle performance levels**, see table below. Each conceptual aircraft summarises the key enabling technologies, including engines, developed in Clean Sky 2.

Conceptual aircraft / air transport type	Reference a/c*	Window ¹	ΔCO ₂	ΔNO _x	Δ Noise	Target ² TRL @ CS2 close
Advanced Long-range (LR)	LR 2014 ref	2030	20%	20%	20%	4
Ultra advanced LR	LR 2014 ref	2035+	30%	30%	30%	3
Advanced Short/Medium-range (SMR)	SMR 2014 ref	2030	20%	20%	20%	5
Ultra-advanced SMR	SMR 2014 ref	2035+	30%	30%	30%	4
Innovative Turboprop (TP), 130 pax	2014 130 pax ref	2035+	19 to 25%	19 to 25%	20 to 30%	4
Advanced TP, 90 pax	2014 TP ref ⁴	2025+	35 to 40%	> 50%	60 to 70%	5
Regional Multimission TP, 70 pax	2014 Multi-mission	2025+	20 to 30%	20 to 30%	20 to 30%	6
19-pax Commuter	2014 19 pax a/c	2025	20%	20%	20%	4-5
Low Sweep Business Jet	2014 SoA Business a/c	2035	> 30%	> 30%	> 30%	≥ 4
Compound helicopter ³	TEM 2020 ref (CS1)	2030	20%	20%	20%	6
Next-Generation Tiltrotor	AW139	2025	50%	14%	30%	5

¹¹⁸ See the definition under Article 2.1 (2) of the H2020 Rules for Participation

¹¹⁹ JOL_2014_169_R_0006

*The reference aircraft will be further specified and confirmed through the Technology Evaluator assessment work.

- 1 All key enabling technologies at TRL 6 with a potential entry into service five years later.
- 2 Key enabling technologies at major system level. The target TRL indicates the level of maturity and the level of challenge in maturing towards potential uptake into marketable innovations.
- 3 Assessment v. comparable passenger journey, not a/c mission.
- 4 ATR 72 airplane, latest SOA Regional A/C in-service in 2014 (technological standard of years 2000), scaled to 90 Pax.

To integrate, demonstrate and validate the most promising technologies capable of contributing to the CS2 high-level and programme specific objectives, the CS2 technology and demonstration activity is structured in **key (technology) themes**, further subdivided in a number of **demonstration areas**, as depicted below. A demonstration area may contribute to one or more objectives and also may involve more than one ITD/IADP.

Ref-Code	Theme	Demonstration area
1A	Breakthroughs in Propulsion Efficiency (incl. Propulsion-Airframe Integration)	Advanced Engine/Airframe Architectures
1B		Ultra-high Bypass and High Propulsive Efficiency Geared Turbofans
1C		Hybrid Electric Propulsion
1D		Boundary Layer Ingestion
1E		Small Aircraft, Regional and Business Aviation Turboprop
2A	Advances in Wings, Aerodynamics and Flight Dynamics	Advanced Laminar Flow Technologies
2B		Regional Aircraft Wing Optimization
3A	Innovative Structural / Functional Design - and Production System	Advanced Manufacturing
3B		Cabin & Fuselage
3C		Innovative Solutions for Business Jets
4A	Next Generation Cockpit Systems and Aircraft Operations	Cockpit & Avionics
4B		Advanced MRO
5A	Novel Aircraft Configurations and Capabilities	Next-Generation Civil Tiltrotor
5B		RACER Compound Helicopter
6A	Aircraft Non-Propulsive Energy and Control Systems	Electrical Systems
6B		Landing Systems
6C		Non-Propulsive Energy Optimization for Large Aircraft
7A	Optimal Cabin and Passenger Environment	Environmental Control System
7B		Innovative Cabin Passenger/Payload Systems
8A	Eco-Design	
9A	Enabling Technologies	
	Technology Evaluator	

The individual topic descriptions provide more detailed information about the link/contribution to the high-level objectives.

4. Clean Sky 2 – Thematic Topics

I. JTI-CS2-2018-CFP09-THT-03: Conceptual Design of a 19 passenger Commuter Aircraft with near zero emissions

Type of action (RIA/IA/CSA):		RIA	
Programme Area:		N/A	
(CS2 JTP 2015) WP Ref.:		N/A	
Indicative Funding Topic Value (in k€):		750	
Topic Leader:	N/A	Type of Agreement:	N/A
Duration of the action (in Months):	36*	Indicative Start Date (at the earliest)¹²⁰:	Q3 2019

*The JU considers that proposals requesting a contribution of 750k€ over a period of 36 months would allow this specific challenge to be addressed appropriately. Nonetheless, this does not preclude submission and selection of proposals requesting other amounts and/or proposing different activity durations.

Topic Identification Code	Title
JTI-CS2-2018-CFP09-THT-03	Conceptual Design of a 19 passenger Commuter Aircraft with near zero emissions
Short description	
<p>This thematic topic focuses on the design of a 19 passenger commuter aircraft based on alternative propulsion concepts (electric, hybrid/electric, fuel cells, etc.) targeting near-zero CO₂ emissions. Architectures may include (but are not limited to) concepts based on a jet-fuel powered (piston or turbine) generator providing electric power, recharging batteries and driving propellers or fans (distributed or not) through electrical engines, full electric aircraft, or propulsion using alternative energy systems and energy carriers like fuel cells, hydrogen, LNG etc. A full design loop is required, evaluating a range of design options, resulting in a mature conceptual design for the selected design. The design should be compliant with the new level 4 FAR23 / CS23 regulation, range and payload and operating parameters may be optimized. The expected project outcome would include a gap analysis and roadmap for performance critical technologies, the sizing and layout of system components, including fault tolerance scenarios, and quantified environmental performance gains, including a full LCA analysis of the proposed concepts.</p>	

Links to the Clean Sky 2 Programme High-level Objectives¹²¹				
This topic is located in the demonstration area:		NA		
The outcome of the project will mainly contribute to the following conceptual aircraft/air transport type as presented in the scene setter:		NA		
With expected impacts related to the Programme high-level objectives:				
Reducing CO₂ emissions	Reducing NO_x emissions	Reducing Noise emissions	Improving EU Competitiveness	Improving Mobility
<input checked="" type="checkbox"/>	<input checked="" type="checkbox"/>	<input checked="" type="checkbox"/>	<input checked="" type="checkbox"/>	<input checked="" type="checkbox"/>

¹²⁰ The start date corresponds to actual start date with all legal documents in place.

¹²¹ For further info see Chapter 1 "Introduction to the Programme Scene Setter / Objectives" with key technology themes / demonstration areas. Detailed information available in the CS2 Development Plan accessible via the Clean Sky JU Website and EC Participant Portal.



1. Specific challenge

A number of activities are currently ongoing in the frame of the Small Air Transport (SAT) transverse activity and Engines ITD in Clean Sky 2 Programme.

These are related to the development of advanced engine demonstrators:

- Reliable small gas turbines (turboprop) for short range/regional aircraft (up to 19 seats), in the power range below 1800 hp (thermal), for 2 different configurations :
 - high-speed, high altitude, pressurized a/c
 - low-speed, low altitude, unpressurized a/c
- Light-weight jet-fueled (Diesel cycle) piston engines for general aviation and commuter aircraft (9 to 12 seats) in the range of 200-400 hp.
- High Power Density Engine concept (2.5kW/kg or 160kW/l) with target application as power generation unit in the range of 300kW to 1MW.

On the other hand, hybrid-electric propulsion and pure electric propulsion are widely seen as having the potential to bring strong and disruptive gains in overall aircraft energy efficiency and emissions reductions, in particular when combined with the potential for relaxing design constraints related to current aircraft designs and making use of e.g. distributed propulsion, energy carriers such as advanced batteries and fuel-cells; and advanced airframe/propulsion integration.

However, the limitation in specific energy storage capacity of today's battery technology probably leads to favour hybrid-electric propulsion concepts instead of full-electric configurations. Depending on the size of the aircraft, the power generation unit could be an internal combustion engine (ICE), typically a piston engine for general aviation and commuter aircraft up to 19 seats or a turbine for larger regional aircraft.

This thematic topic focuses on the aircraft design of a 19 passenger commuter aircraft based on alternative propulsion concepts (electric, hybrid/electric, fuel cells, etc.) targeting near zero CO₂ emission.

Architectures may include (but are not limited to) concepts based on a jet-fuel powered (piston or turbine) generator providing electric power, recharging batteries and driving propellers or fans (distributed or not) through electrical engines, full electric aircraft, or propulsion using alternative energy systems and energy carriers like fuel cells, hydrogen, LNG etc. A full design loop is required, evaluating a range of design options, resulting in a mature conceptual design for the selected design. The design should be compliant with the new level 4 FAR23 / CS23 regulation, range and payload and operating parameters may be optimized.

The expected project outcome would include a gap analysis and roadmap for performance critical technologies, the sizing and layout of system components, including fault tolerance scenarios, and quantified environmental performance gains, including a full LCA analysis of the proposed concepts.

2. Scope

The action will depart from an analysis and literature review of the State of the Art [SoA] of research and/or developments underway in the field of future alternative propulsion architectures, in their various concepts and state of technology readiness.

at the systems level, the research should focus on efficiency and TRL of each component of the power train, i.e. energy storage systems, powerplant, generator, power distribution and conversion, electric



motors and propulsors.

Such propulsors can be one or more propellers, shrouded fans, or a distributed propulsion system. At the integrated system level the power train architecture shall be optimized for efficiency and mass, and inherent issues such as (but not limited to) electro-magnetic interference and compatibility, arcing and component cooling should be systematically addressed.

Feasibility should be assessed and concepts should be proposed first using state-of-the-art components or assuming near term and realistic performance targets, after which evolutionary concepts may be proposed based on reasonable assumptions regarding performance levels to be achieved in the longer term future.

Research at the aircraft level will focus on the integration of the power train components in the airframe and analyse efficient new aircraft configurations taking into account the peculiarities and enabling properties of hybrid-electric propulsion systems.

A holistic optimization approach is required at the aircraft level with respect to mass and centre of gravity, power management strategies, certification requirements, fuel/energy consumption and related emissions, community noise, infrastructure compatibility and acquisition and operating cost.

The work needs to include an analysis of the various fault scenarios for both the electric machine(s) and the power converter(s) for the various architectures under investigation, to confirm their fulfillment of the fault-tolerance requirements of the alternative power train concept for a 19 passenger commuter a/c.

Clear and quantified environmental performance predictions should be stated for the proposed architecture(s) in terms of CO₂, NO_x and Noise.

The aircraft design study should also include a full Life Cycle Analysis (LCA) of the proposed architecture(s).

3. Expected outcomes/impact

The expected outcome of the project would be the completion of the aircraft design up to a typical Preliminary Design Review. The objective of the project would be to collect all elements necessary to proceed to a next step, such as an iron bird demonstrator or eventually a flight demonstrator, however outside of the scope of this topic.

The project outcomes should include:

- An analysis and literature review of the State of the Art [SoA] of research and/or developments underway in the field of alternative propulsion architectures, in their various concepts and state of technology readiness in order to demonstrate the feasibility and benefits of alternative power train concepts to the field of flight transportation for small commuter a/c.
- A full design loop taking multiple configurations, architectures and alternative solutions into consideration, with a suitable multi-variable trade study determining the selected design option.
- The resulting conceptual design of the aircraft, including 3D CFD aerodynamic simulations, preliminary structural design calculations, the sizing and layout of principal components,
- The primary performance parameters and propulsion system fault-tolerance scenarios related to the reliability/availability criteria
- The quantified environmental targets and LCA for the down-selected architecture.
- The identification of scientific and technical challenges for the successful deployment of such architectures, and specifically categorization and specification of gaps from the current SoA to the required performance for a viable commuter size aircraft.



- Advise on the required steps towards the progress needed in improving individual system components performance.
- Upgrade potential: indicate the potential for aircraft performance improvement (specifically regarding payload/range capability) based on technology insertion at component level [e.g. higher energy density batteries or more efficient Diesel engine cycles, fuel cells, etc.]

4. Topic special conditions

Special conditions apply to this topic:

- **Page limit:**

The limit for a full proposal answering a Thematic Topic is **30 pages** in total, see proposal template B.I.

- **Scoring and weighting:**

For Thematic Topics: to determine the ranking, the score for the criterion 'excellence' will be given a weight of 1.5.

- **Admissibility:**

Standard admissibility conditions and related requirements as laid down in Part B of the General Annex of the Work Programme shall apply mutatis mutandis with the following additional condition(s) introduced below:

- The 16 Leaders of JU listed in Annex II to Regulation n° (EU) No 558/2014 and their affiliates¹²² **may not apply** to the topics listed in this call text document.

¹²² See the definition under Article 2.1 (2) of the H2020 Rules for Participation

II. JTI-CS2-2018-CFP09-THT-04: Aircraft Design Optimisation providing optimum performance towards limiting aviation's contribution towards Global Warming

Type of action (RIA/IA/CSA):		RIA	
Programme Area:		N/A	
(CS2 JTP 2015) WP Ref.:		N/A	
Indicative Funding Topic Value (in k€):		750	
Topic Leader:	N/A	Type of Agreement:	N/A
Duration of the action (in Months):	36*	Indicative Start Date (at the earliest)¹²³:	Q3 2019

**The JU considers that proposals requesting a contribution of 750k€ over a period of 36 months would allow this specific challenge to be addressed appropriately. Nonetheless, this does not preclude submission and selection of proposals requesting other amounts and/or proposing different activity durations.*

Topic Identification Code	Title
JTI-CS2-2018-CFP09-THT-04	Aircraft Design Optimisation providing optimum performance towards limiting aviation's contribution towards Global Warming
Short description	
<p>Mitigating aviation's contribution to climate change through its various emissions (including but not limited to CO₂) will require new and increasingly more disruptive technologies. A reduced global warming impact could be achieved by relaxing the design constraints typically set, such as (but not limited to) aircraft design payload/range, cruise speed and cruise altitude. This topic asks for a multi-disciplinary optimization based on various <i>cost functions</i> such as operating cost, CO₂, NO_x, soot/particulate matter, as well as the likelihood of contrail induced cirrus formation as a function of the aircraft/engine design parameters (payload, range, cruise Mach number and altitude, etc.). An estimation of the mitigation potential by deviating from current typical operational parameters and current aircraft is expected. For a given design, an estimate of the sensitivity to operating parameters such as speed and altitude should be given. Selected projects should allow the coverage of two key air transport market segments: the passenger long-haul market segment as well as the short to medium range segment. Proposers should select design payload/range metrics that correspond with typical aircraft utilization for instance selecting route coverage up to a representative percentile of existing traffic flows. Proposers are free to select one, or both market segments and to define a relevant reference aircraft; and subsequently to present aircraft concepts that provide climate optimised performance. The CS2 Technology Evaluator can provide a validation opportunity within the CS2 environmental assessment.</p>	

Links to the Clean Sky 2 Programme High-level Objectives¹²⁴				
This topic is located in the demonstration area:				NA
The outcome of the project will mainly contribute to the following conceptual aircraft/air transport type as presented in the scene setter:				NA
With expected impacts related to the Programme high-level objectives:				
Reducing CO₂ emissions	Reducing NO_x emissions	Reducing Noise emissions	Improving EU Competitiveness	Improving Mobility
<input checked="" type="checkbox"/>	<input checked="" type="checkbox"/>	<input type="checkbox"/>	<input checked="" type="checkbox"/>	<input checked="" type="checkbox"/>

¹²³ The start date corresponds to actual start date with all legal documents in place.

¹²⁴ For further info see Chapter 1 "Introduction to the Programme Scene Setter / Objectives" with key technology themes / demonstration areas. Detailed information available in the CS2 Development Plan accessible via the Clean Sky JU Website and EC Participant Portal.



1. Specific challenge

The specific challenge associated to this topic is to address the issue of global warming minimization from a multi-parametric and multi-disciplinary design optimization approach.

In addition to CO₂, the climate impact of aviation is strongly influenced by non-CO₂ emissions, such as nitrogen oxides, influencing ozone and methane, soot and particulate matter, sulfides and aromatics; and water vapour, which can lead through persistent contrails in ice-supersaturated regions to cirrus cloud formation. For a number of these non-CO₂ emission effects, their climate impact largely depends on local atmospheric conditions and as such on the location and time of emissions. Mitigating these climate impacts might thus require 'smart' route planning in (near) real-time and selection of e.g. different cruise altitude and speed. The potential therefore exists to reduce the environmental impact of air transport by selecting routes, flight altitudes and cruise speeds that assist in avoiding the emissions effects that contribute to global warming.

The aim of this study is not to determine the route-specific or 'real-time' operational optima as these have been covered in previous and ongoing research (e.g. REACT4C and ATM4E, and through the SESAR JU Programme). Rather the aim is to build on earlier research efforts that have recognized the potential for significant reductions in overall global warming effect of aviation by selecting a different aircraft design optimum that can provide material reductions in the global warming effect of operations across statistically relevant conditions and operating regions [geographical and temporal / seasonal effects].

A change in cruise altitude, for example, can be effective in reducing/eliminating persistent contrails and contrail induced cirrus leading to AIC (aviation induced cloudiness). However, it is likely to increase the rate of fuel consumption, unless a different overall design and related cruise airspeed is selected. Consequently, non-CO₂ radiative forcing would reduce, but CO₂ radiative forcing (which has a long-term influence) may increase unless mitigated through alternative design parameters. It is theoretically possible to build a climate cost function for the aircraft concept / design. The optimum aircraft configuration would be established through optimization of the cost function against a statistically relevant 'basket' of operating conditions (regions and traffic flows, routes, schedules). Such a climate cost function would describe the airplane's contribution to climate change at a certain time and location in the atmosphere resulting from H₂O and CO₂ production, other emissions; ozone formation, methane loss, methane-induced ozone change, contrails, and AIC.

Analysis at fleet level and across a relevant set of expected operations would lead to an estimate of the potential for reducing overall global warming impact of the design, against a relevant reference of today's fleet.

Subsequently, comparing relative operating costs, mission level block times, fuel, consumption and emissions, as well as LTO [landing and take-off] emissions and noise, would inform as to the potential 'cost' in other criteria of such a global warming optimized design

2. Scope

The scope of this topic is not to develop a multi-disciplinary optimization tool. The objective is to use such a tool to apply it to solving the minimization of a climate cost function. This climate cost function must therefore be appropriately defined, knowing that a number of different metrics exist.

This study should also include the definition or the choice of appropriate metrics, which is best suited to assess the global warming impact.



There are for the moment several metrics, which are used in this context, which are often used:

- Radiative Forcing RF in $W/m^2/kg$
- Warming Potential in $J/m^2/kg$
- Temp. Change Potential in K/kg
- Temperature Change in K or 'Accumulated Temperature Response' [ATR] in K.

As can be seen already by the different units, these metrics are quite different and may lead to different conclusions in some cases. There is no "best metric" to cover all the complex chemistry of interaction and finally the impact of air transport, but this issue should be addressed by applicants.

Following the discussion on the metrics and climate cost function, the impact of an aircraft design on the air transport on gaseous emissions and on noise has to be distinguished and deserves special attention.

Noise clearly needs to be considered in the complete assessment of alternative concepts. Applicants should consider that concepts proposed should be fully compliant with noise regulations in existence and currently on the horizon [ICAO CAEP], and with ample margin.

Although some previous research has also included minimum noise designs compared to minimum fuel, minimum NO_x or minimum operating cost designs, this study should focus essentially on operational parameters in cruise considering the main design variables as the aircraft type and geometry (including relevant technologies, like laminar wings, composite fuselage, etc.) as well as the main engine parameters (BPR, OPR, TET, Thrust-to-Weight Ratio, etc.) engine/propulsion type (turbofan, geared turbofan, as well as more disruptive concepts such as but not limited to unducted single fan, contra-rotating open-rotor, distributed propulsion concepts). For this particular study, current aviation fuels shall be assumed as primary energy carrier, and no benefits or performance gains attributed to e.g. bio-fuels, alternative sustainable fuels or chemistries.

As the operational parameters such as cruise altitude, speed and routings might affect airspace capacity at certain flight levels a coordination with SESAR will be pursued.

3. Expected outcomes/impact

- Analysis of previous research into the overall climate impact of aviation and in particular for the sensitivity of this impact to aircraft operating parameters such as cruise speed and altitude, as well as the SoA of understanding the interaction between atmospheric conditions and operating parameters [projects such as REACT4C et. al.]
- SoA of previous optimization studies, and metrics used for global warming metrics.
- Analysis, selection and development of the most suited climate cost function
- Emissions (CO_2 / NO_x / Particulates / Aromatics / Water Vapour and Noise) prediction models and sensitivity to operating parameters such as flight altitude, Mach number)
- Aircraft/Engine Design and Performance Models including the effect of engine parameters such as OPR/BPR on the emissions 'species' and in particular on contrail formation with flight altitude.

Applicants should select an appropriate predictive model of air traffic flows that allows statistically relevant selection of the overall market's composition and a selection of the conceptual aircraft's design payload and range.

The final expected outcome would be the presentation of one or more conceptual aircraft designs that



allow to understand what the optimum aircraft/engine design combination (for both short-medium and long range market segments) is, that would yield the minimum climate. The related impact of these selected designs on operating cost, block times, LTO emissions and noise should be provided as comparative performance estimates against current state of the art aircraft in service. For the aforementioned market segments, the proposers are free to select one, or both, to define a relevant reference aircraft and to present various aircraft concepts that meet the climate optimised performance challenge. The CS2 Technology Evaluator can provide a validation opportunity against the TE models which are being used for the CS2 environmental assessment.

4. Topic special conditions

Special conditions apply to this topic:

- **Page limit:**

The limit for a full proposal answering a Thematic Topic is **30 pages** in total, see proposal template B.I.

- **Scoring and weighting:**

For Thematic Topics: to determine the ranking, the score for the criterion 'excellence' will be given a weight of 1.5.

- **Admissibility:**

Standard admissibility conditions and related requirements as laid down in Part B of the General Annex of the Work Programme shall apply mutatis mutandis with the following additional condition(s) introduced below:

- The 16 Leaders of JU listed in Annex II to Regulation n° (EU) No 558/2014 and their affiliates¹²⁵ **may not apply** to the topics listed in this call text document.

¹²⁵ See the definition under Article 2.1 (2) of the H2020 Rules for Participation

III. JTI-CS2-2018-CFP09-THT-05: Advanced High Bypass Ratio Low-Speed Composite Fan Design and Validation

Type of action (RIA/IA/CSA):		RIA	
Programme Area:		N/A	
(CS2 JTP 2015) WP Ref.:		N/A	
Indicative Funding Topic Value (in k€):		2000	
Topic Leader:	N/A	Type of Agreement:	N/A
Duration of the action (in Months):	48*	Indicative Start Date (at the earliest)¹²⁶:	Q3 2019

*The JU considers that proposals requesting a contribution of 2000k€ over a period of 48 months would allow this specific challenge to be addressed appropriately. Nonetheless, this does not preclude submission and selection of proposals requesting other amounts and/or proposing different activity durations.

Topic Identification Code	Title
JTI-CS2-2018-CFP09-THT-05	Advanced High Bypass Ratio Low-Speed Composite Fan Design and Validation
Short description	
<p>The objectives of this topic would be to:</p> <ul style="list-style-type: none"> ▪ Establish a state-of-the-art review in composite low-speed fan design methods and available experiments. Both at the level of composite fan manufacturing and design methods. ▪ Provide a specific design, able to highlight expected instability phenomena, suitable for experimental validation of complex multi-physical phenomena in view of establishing a European test case (experimental database) available under open access for other institutions to validate their design methods. ▪ Manufacture and test the low-speed composite fan model and establish an exhaustive experimental database as an open test case, with aerodynamic, aero-elastic and aero-acoustic data. 	

Links to the Clean Sky 2 Programme High-level Objectives¹²⁷				
This topic is located in the demonstration area:				NA
The outcome of the project will mainly contribute to the following conceptual aircraft/air transport type as presented in the scene setter:				NA
With expected impacts related to the Programme high-level objectives:				
Reducing CO₂ emissions	Reducing NO_x emissions	Reducing Noise emissions	Improving EU Competitiveness	Improving Mobility
<input checked="" type="checkbox"/>	<input checked="" type="checkbox"/>	<input checked="" type="checkbox"/>	<input checked="" type="checkbox"/>	<input checked="" type="checkbox"/>

¹²⁶ The start date corresponds to actual start date with all legal documents in place.

¹²⁷ For further info see Chapter 1 "Introduction to the Programme Scene Setter / Objectives" with key technology themes / demonstration areas. Detailed information available in the CS2 Development Plan accessible via the Clean Sky JU Website and EC Participant Portal.



1. Specific challenge

After decades of development and improvement of metallic fan blade design, a new era has come. With the recent advent of geared turbofan architectures, low-speed, high bypass, composite fan systems have been introduced. However, partially due to the understanding of the composite material behavior, as well as the complex design optimization at aerodynamic, aero-elastic and aero-acoustic level, substantial work remains to be done and a detailed understanding of multi-physical coupling mechanisms which impact stable operation is required. As already said, the use of highly loaded blades with composite material involves aerodynamic, aero-elastic and aero-acoustic phenomena. Although models considering each of the sub-disciplines individually have been successfully validated and applied, current approaches fail to predict periodic and transient phenomena in highly coupled systems. Particularly the fundamental understanding of the aero-elastic behaviour of composite-materials is crucial for a robust design.

An investigation of individual effects on reduced models produces misleading results due to nonlinear physical interactions, particularly if they involve different spatial and temporal scales. To overcome this problem, it is necessary to develop multi-physical analysis and design methods.

To achieve a comprehensive understanding of the coupling phenomena in the European research community, an open-test-case that can serve as a benchmark vehicle for interdisciplinary method development is highly desirable. It is necessary that this test-case shows instability mechanisms that are representative of modern and future applications, specifically UHBR fans (low transonic). This includes flutter at highly loaded operating points and the effect of asymmetry (e.g. inlet distortion; boundary layer ingestion, potential effect of engine pylon, intentional mistuning).

A detailed experimental investigation of the test case with advanced measurement systems that allows an exhaustive characterization of individual physical phenomena is required. To clearly derive the chain of cause and effect for coupled instability mechanisms, a synchronized investigation of all relevant physical parameters needs to be accomplished. This involves the resolution of unstable aerodynamic flow structures in the rotating frame of reference that can be in acoustic or mechanical resonance. One main goal of the project is to derive sensitivity parameters that have to be considered to design a robust system (e.g. aerodynamic and/or structural mistuning). The anticipated results of this initiative are of fundamental nature and of general interest for academic research. To meet the demanding challenge a close cooperation between leading research institutes needs to be established to ensure a purposeful design of experiments and a comprehensive analysis of the derived data.

This topic offers further potential to extend this study to the effect of different material parameters, like fibre orientation or composite manufacturing techniques, as well as other aerodynamic parameters, like tip clearance effects, or casing treatments for improved operational stability or acoustic treatments for noise reduction.

2. Scope

The scope of this study should be focused on designing an Open-Test-Case Fan geometry that will develop instability mechanisms which are representative for civil aircraft fans with Ultra-high-bypass-ratio and perform a comprehensive experimental investigation. The geometry and the structural properties will be shared within the European research community to serve as a benchmark validation case for multi-physical design method development and validation.

This study will fully exploit the philosophy of the European Open Access of Data and Publication Policy based on a turbo machinery low speed composite fan test case.



3. Expected outcomes/impact

The project outcomes should achieve the following objectives:

- An analysis and literature review of the State of the Art [SoA] of research in relation with aerodynamic, aero-elastic and aero-acoustic instability phenomena in low speed fans as well as the current understanding of their coupling mechanisms and consequences.
- Provide a specific design, able to highlight expected instability phenomena, suitable for experimental validation of complex multi-physical phenomena in view of establishing a European test case (experimental database) available under open access for other institutions to validate their design methods.
- Manufacture and test the low-speed composite fan model and establish an exhaustive experimental database as an open test case, with aerodynamic, aero-elastic and aero-acoustic data.

4. Topic special conditions

Special conditions apply to this topic:

- **Page limit:**

The limit for a full proposal answering a Thematic Topic is **30 pages** in total, see proposal template B.I.

- **Scoring and weighting:**

For Thematic Topics: to determine the ranking, the score for the criterion 'excellence' will be given a weight of 1.5.

- **Admissibility:**

Standard admissibility conditions and related requirements as laid down in Part B of the General Annex of the Work Programme shall apply mutatis mutandis with the following additional condition(s) introduced below:

- The 16 Leaders of JU listed in Annex II to Regulation n° (EU) No 558/2014 and their affiliates¹²⁸ **may not apply** to the topics listed in this call text document.

¹²⁸ See the definition under Article 2.1 (2) of the H2020 Rules for Participation

IV. JTI-CS2-2018-CFP09-THT-06: Research for the development of Particulate Matter (PM) regulations and guidelines

Type of action (RIA/IA/CSA):		RIA	
Programme Area:		N/A	
(CS2 JTP 2015) WP Ref.:		N/A	
Indicative Funding Topic Value (in k€):		1000	
Topic Leader:	N/A	Type of Agreement:	N/A
Duration of the action (in Months):	36*	Indicative Start Date (at the earliest)¹²⁹:	Q3 2019

**The JU considers that proposals requesting a contribution of 1000k€ over a period of 36 months would allow this specific challenge to be addressed appropriately. Nonetheless, this does not preclude submission and selection of proposals requesting other amounts and/or proposing different activity durations.*

Topic Identification Code	Title
JTI-CS2-2018-CFP09-THT-06	Research for the development of Particulate Matter (PM) regulations and guidelines
Short description	
<p>The objectives of this topic would be to:</p> <ul style="list-style-type: none"> ▪ Bring together European state-of-the-art research efforts on understanding, predicting and modeling aviation particulate matter [PM] emissions in order to support a European roadmap for developing new NvPM technologies; ▪ Deepen the understanding of PM emitted by aircraft engines and provide a better understanding of their impact on health at and around airports and on the global atmosphere. ▪ Support the development of guidelines and methodologies for aircraft engine data and modeling capabilities related to PM, in view of ICAO CAEP 11 and beyond. ▪ Assist EASA and the European Commission (RTD, MOVE, CLIMA, ENVI) in developing NvPM regulations and guidelines. 	

Links to the Clean Sky 2 Programme High-level Objectives ¹³⁰				
This topic is located in the demonstration area:				NA
The outcome of the project will mainly contribute to the following conceptual aircraft/air transport type as presented in the scene setter:				NA
With expected impacts related to the Programme high-level objectives:				
Reducing CO₂ emissions	Reducing NO_x emissions	Reducing Noise emissions	Improving EU Competitiveness	Improving Mobility
<input checked="" type="checkbox"/>	<input checked="" type="checkbox"/>	<input type="checkbox"/>	<input checked="" type="checkbox"/>	<input checked="" type="checkbox"/>

¹²⁹ The start date corresponds to actual start date with all legal documents in place.

¹³⁰ For further info see Chapter 1 "Introduction to the Programme Scene Setter / Objectives" with key technology themes / demonstration areas. Detailed information available in the CS2 Development Plan accessible via the Clean Sky JU Website and EC Participant Portal.



1. Specific challenge

Climate and environmental changes are defining challenges of our times and are well-reflected in the conclusions and recommendations of the Intergovernmental Panel on Climate Change (IPCC). The impact of aviation on the environment and the climate is relatively small but growing steadily. It is driven by long-term effects (several hundreds of years) from CO₂ emissions and shorter-term ones (from several decades) from non-CO₂ emissions (water vapour, particles and nitrogen oxides). While the CO₂ effects are well understood, the non-CO₂ effects carry large uncertainties. The European Union and its Member States strongly support ICAO's initiatives on a "basket of measures" (technologies, operational, alternative fuels and market-based measures) that aim to address the climate impacts of aviation.

Beyond the climate and environmental impact, aircraft particulate matter emissions during taxing, take-off and landing pose a risk to human health, particularly in communities near airports. In addition, PM emissions at cruising altitudes are believed to modify the composition of the atmosphere and hence the earth's radiative budget.

NvPM emitted from aircraft engines has not been regulated till recently. The standard proposed at CAEP/10 is based on older Smoke Number values and is considered to be an "all-pass" standard, mainly aimed at collecting more data. It is crucial to gather data from NvPM measured at the exhaust of aircraft engines to be able to set a robust standard based on current technology. The Directive 2008/50/EC on ambient air quality and cleaner air for Europe sets legally binding limits for concentrations of major air pollutants that impact public health (PM₁₀, PM_{2.5}, SO₂, C₆H₆, CO, Pb, NO₂). Recent studies suggested that the main concern at airports is related to UFP (Ultra Fine Particles: with a size below 0.1 µm PM_{0.1}) from aircraft and diesel engines.

Over the last two decades in Europe and the USA, a stream of research efforts¹³¹ have been launched to quantify NvPM emissions and better understand the adverse impacts to the climate and human health. In view of ongoing ICAO CAEP efforts towards developing a more meaningful standard for NvPM, as well as European Commission air-quality actions¹³², there is a need to consolidate European expertise, assess the gaps and advance further in a coordinated manner.

The main objective of this topic is to bring together the long-standing expertise from European academia, research labs, industry and European regulatory bodies in a holistic manner, towards a better understanding of the potential for new technologies, and towards supporting sound and robust NvPM regulations and guidelines. This should be complemented with the pooling and development of European modelling capabilities in the area to support standard setting and assessment of the problem, and could include where needed the data acquisition concerning NvPM emissions from various categories of engines.

In addition, the potential for NvPM reductions from Sustainable aviation fuels should be assessed. Options should be developed and proposed to acquire NvPM data in a more efficient and cost effective manner, e.g. through the use of combustor rigs.

¹³¹ Representative examples include: FP5-PartEmis, FP5-NEPAIR, FP5-TRADEOFF, FP5-INCA, FP5-AERO2K, FP5- METRIC, FP5-SCENIC, FP6-ATTICA, FP6-QUANTIFY, FP7-FORUM-AE, FP7-REACT4C, MERMOSE, EASA-SAMPLE-III, SESAR2020-ATM4E, US-PARTNER, Swiss-ETH-EMPA-FOCA studies.

¹³² European Commission, Press Release – Air Quality: Commission takes action to protect citizens from air pollution, 17 May 2018.



2. Scope

The scope of this research action should be focused on bringing together European research efforts from Industry, academia and research institutes on aviation particulate matter towards building a robust understanding of the formation of NVPM in aircraft operations and to develop essential tools for supporting sound regulations addressing the issues. Where possible use should be made of existing datasets and data collection in Europe or elsewhere in the world, complemented where needed with data acquisition related to aircraft engine emissions.

3. Expected outcomes/impact

The project outcomes should achieve the following objectives:

- Deliver a repository of current best understanding of the mechanisms that lead to formation of NVPM in aircraft operations and potential options and technologies to mitigate those emissions. In this context consider the impact of fuel composition on NVPM emissions, the NVPM emissions from engines with thrust below 26.7 kN and engines certificated on shaft power.
- Deliver an assessment and quantification of interdependencies with other environmental characteristics such as NO_x, CO₂, and noise.
- Develop a modelling method and associated software tool able to predict NVPM emission and associated interdependency effects from aircraft operations as the source, based on pooling together current best understanding of the mechanisms.
- Develop a modelling method and software tool able to predict NVPM emissions at and around an airport, based on source characteristics as available from past measurement campaigns or from the results of modelling of aircraft operations (previous point). The proposals should take into account the transformation in the plume of volatile PM including results of work in other relevant EU projects. This deliverable aims to assist the European Commission and EASA to develop PM related policy, regulations and guidelines, including advice on measurement methodologies for NVPM using a combustor rig.

4. Topic special conditions

Special conditions apply to this topic:

- **Page limit:**

The limit for a full proposal answering a Thematic Topic is **30 pages** in total, see proposal template B.I.

- **Scoring and weighting:**

For Thematic Topics: to determine the ranking, the score for the criterion 'excellence' will be given a weight of 1.5.

- **Admissibility:**

Standard admissibility conditions and related requirements as laid down in Part B of the General Annex of the Work Programme shall apply mutatis mutandis with the following additional condition(s) introduced below:

- The 16 Leaders of JU listed in Annex II to Regulation n° (EU) No 558/2014 and their affiliates¹³³ **may not apply** to the topics listed in this call text document.

¹³³ See the definition under Article 2.1 (2) of the H2020 Rules for Participation